

SLG 700
SmartLine Level Transmitter
Guided Wave Radar
User's Manual

34-SL-25-11
Revision 8.0
December 2017

Copyrights, Notices and Trademarks

© Copyright 2017 by Honeywell International
Revision 8.0, December 2017

While the information in this document is presented in good faith and believed to be accurate, Honeywell disclaims any implied warranties of merchantability and fitness for a particular purpose and makes no express warranties except as may be stated in the written agreement with and for its customers. In no event is Honeywell liable to anyone for any indirect, special, or consequential damages. The information and specifications in this document are subject to change without notice.

Honeywell, TDC3000, SFC, SmartLine, PlantScape, Experion PKS, and TotalPlant are registered trademarks of Honeywell International Inc. Other brand or product names are trademarks of their respective owners.

Honeywell Process Solutions
1250 W Sam Houston Pkwy S
Houston, TX 77042

About This Manual

This manual is a detailed how to reference for installing, wiring, configuring, starting up, operating, maintaining, calibrating, and servicing Honeywell's family of SLG 700 SmartLine Guided Wave Radar Level Transmitters. Users who have a Honeywell SLG 700 SmartLine Guided Wave Radar Level Transmitter configured for HART® protocol are referred to the SLG 700 Series HART® Option User's Manual, Document #34-SL-25-06. Users who have a Honeywell SLG 700 SmartLine Guided Wave Radar Level Transmitter configured for Fieldbus operation are referred to the SLG 700 Series Foundation™ Fieldbus Option User's Manual, Document #34-SL-25-07.

The configuration of your Transmitter depends on the mode of operation and the options selected for it with respect to operating controls, displays and mechanical installation. This manual provides detailed procedures to assist first-time users, and it further includes keystroke summaries, where appropriate, as quick reference or refreshers for experienced personnel.

To digitally integrate a Transmitter with one of the following systems:

- For the Experion PKS, you will need to supplement the information in this document with the data and procedures in the Experion Knowledge Builder.
- For Honeywell's TotalPlant Solutions (TPS), you will need to supplement the information in this document with the data in the PM/APM SmartLine Transmitter Integration Manual, which is supplied with the TDC 3000 book set. (TPS is the evolution of the TDC 3000).

Revision History

SLG 700 SmartLine Level Guided Wave Radar Transmitter User's Manual,
Document #34-SL-25-11

Rev. 1.0	March 2015	First release
Rev. 2.0	April 2015	Updates to troubleshooting and Display menus
Rev. 3.0	June 2015	Security Considerations and Vulnerability added.
Rev. 4.0	June 2016	Updates for the R101 release. Including SLG726.
Rev. 5.0	July 2016	Display menus updated.
Rev. 6.0	December 2016	False Echo suppression, improved interface thickness
Rev. 7.0	February 2017	Troubleshooting section and Fieldbus updates
Rev. 8.0	December 2017	Saturated Steam application (R200)

References

The following list identifies publications that may contain information relevant to the information in this document.

SLG 700 SmartLine Guided Wave Radar Level Transmitter Quick Start Guide,
Document #34-SL-25-04

SLG 700 SmartLine Guided Wave Radar Level Transmitter Safety Manual,
Document #34-SL-25-05

SLG 700 SmartLine Guided Wave Radar Level Transmitter HART Option Manual,
Document #34-SL-25-06

SLG 700 SmartLine Level Transmitter Guided Wave Radar FOUNDATION Fieldbus Option Manual, Document #34- SL-25-07

SLG 700 SmartLine Level Transmitter Product Specification Document #34-SL-03-03

Patents

The Honeywell SLG 700 SmartLine Guided Wave Radar Level Transmitter family is covered by U. S. Patents 9329072, 9329073, 9476753 and 9518856 and 9329074, 9574929, 9618612, 9711838 and their foreign equivalents and other patents pending.

Support and Contact Information

For Europe, Asia Pacific, North and South America contact details, refer to the back page of this manual or the appropriate Honeywell Support web site:

Honeywell Corporate

www.honeywell.com

Honeywell Process Solutions

<https://www.honeywellprocess.com/>*

Honeywell SmartLine Level











<https://www.honeywellprocess.com/smartline-level-transmitter.aspx>



Telephone and Email Contacts

Area	Organization	Phone Number
United States and Canada	Honeywell Inc.	1-800-343-0228 Customer Service 1-800-423-9883 Global Technical Support
Global Email Support	Honeywell Process Solutions	hfs-tac-support@honeywell.com

Symbols Descriptions and Definitions

The following symbols may appear in this document.

Symbol	Definition
	ATTENTION: Identifies information that requires special consideration.
	TIP: Identifies advice or hints for the user, often in terms of performing a task.
CAUTION	Indicates a situation which, if not avoided, may result in equipment or work (data) on the system being damaged or lost, or may result in the inability to properly operate the process.
	CAUTION: Indicates a potentially hazardous situation which, if not avoided, may result in minor or moderate injury. It may also be used to alert against unsafe practices. CAUTION symbol on the equipment refers the user to the product manual for additional information. The symbol appears next to required information in the manual.
	WARNING: Indicates a potentially hazardous situation, which, if not avoided, could result in serious injury or death. WARNING symbol on the equipment refers the user to the product manual for additional information. The symbol appears next to required information in the manual.
	WARNING, Risk of electrical shock: Potential shock hazard where HAZARDOUS LIVE voltages greater than 30 Vrms, 42.4 Vpeak, or 60 VDC may be accessible.
	ESD HAZARD: Danger of an electro-static discharge to which equipment may be sensitive. Observe precautions for handling electrostatic sensitive devices.
	Protective Earth (PE) terminal: Provided for connection of the protective earth (green or green/yellow) supply system conductor.
	Functional earth terminal: Used for non-safety purposes such as noise immunity improvement. Note: This connection shall be bonded to Protective Earth at the source of supply in accordance with national local electrical code requirements.
	Earth Ground: Functional earth connection. Note: This connection shall be bonded to Protective Earth at the source of supply in accordance with national and local electrical code requirements.
	Chassis Ground: Identifies a connection to the chassis or frame of the equipment shall be bonded to Protective Earth at the source of supply in accordance with national and local electrical code requirements.
	The Factory Mutual® Approval mark means the equipment has been rigorously tested and certified to be reliable.

Symbol	<u>Definition</u>
	<p>The Canadian Standards mark means the equipment has been tested and meets applicable standards for safety and/or performance.</p>
	<p>The Ex mark means the equipment complies with the requirements of the European standards that are harmonized with the 2014/68/EU Directive (ATEX Directive, named after the French "ATmosphere EXplosible").</p>

Contents

1	Introduction	1
1.1	Overview	1
1.2	Transmitter Models	1
1.3	Transmitter Components	1
1.3.1	Overview of components	1
1.3.2	Electronics Housing	2
1.3.3	Sensor Housing	3
1.3.4	Process Connector	3
1.3.5	Probe	4
1.4	Communicating with the Transmitter	6
1.4.1	4-20 mA HART®	6
1.4.2	FOUNDATION™ Fieldbus (FF)	8
1.4.3	DTM-based tools and Experion	9
1.5	SLG 700 Transmitter nameplate	11
1.6	Transmitter Model Number Description	13
1.7	Safety Certification Information	13
1.7.1	Safety Integrity Level (SIL)	13
1.8	Security Considerations	14
1.9	Measurement Options Licensing	14
2	Radar Level Measurement	15
2.1	Overview	15
2.2	Theory of Operation	15
2.2.1	TDR for Interface and Flooded Measurements	17
2.3	Signal processing configuration	18
2.3.1	Amplitude Tracking	19
2.3.2	Full-tank Detection	19
2.3.3	Maximum Fill Rates, Latching and Timeouts	20
2.4	Signal Interferences and background echoes	21
2.4.1	Field and Obstacle background	21
2.4.2	Static and Dynamic backgrounds	21
2.4.3	Accuracy and measurement range specifications	22
2.5	Process Applications	28
2.5.1	Single Liquid	28
2.5.2	Two Liquid Applications	28
2.5.3	Low Dielectric Applications	30
2.5.4	Steam Boiler Applications	31
2.6	Process Condition Considerations	32
2.6.1	Turbulence	32
2.6.2	Foam or Emulsions	32
2.6.3	FEP Probe	32

2.7	Container Considerations.....	33
2.7.1	Shapes	33
2.7.2	Materials (plastic vs. metal).....	33
2.8	Blocking distance high and blocking distance low guidance	34
2.8.1	Blocking distance high (BDH) guidance.....	34
2.8.2	Blocking distance low (BDL) guidance.....	34
2.8.3	Blocking Distance, Full Tank Detection and Latching modes.....	34
3	Transmitter Installation	36
3.1	Preparation.....	36
3.1.1	Installation sequence	36
3.1.2	Tools.....	37
3.2	Mechanical Installation.....	38
3.2.1	Check for correct probe dimensions and strength	38
3.2.2	Accuracy and measuring range specifications.....	38
3.2.3	Trim the probe length	47
3.2.4	Attach/assemble the probe	48
3.2.5	Centering Disks and configured probe length.....	61
3.2.6	Mounting the transmitter	67
3.2.7	Suitable mounting position	73
3.2.8	Optimum Operating Temperature	74
3.2.9	Temperature requirements.....	75
3.2.10	Mounting on a non-metallic container	83
3.2.11	Rotate transmitter housing	86
3.2.12	Secure the probe.....	86
3.2.13	Install conduit entry plugs and adapters	89
3.2.14	Flange pressure ratings	90
3.2.15	Material Exposed to Tank Atmosphere.....	90
3.3	Electrical Installation	91
3.3.1	Wiring a transmitter	91
3.3.2	HART / 4-20mA Voltage Operating Ranges	91
3.3.3	Terminal Connections	93
3.3.4	FOUNDATION Fieldbus.....	94
3.3.5	Wiring Procedure	94
3.3.6	Lightning Protection	95
3.3.7	Supply Voltage Limiting Requirements	95
3.3.8	Process Sealing	95
3.3.9	Explosion-Proof Conduit Seal	95
4	Operating the Transmitter	96
4.1	User interface options	96
4.1.1	Transmitter advanced displays with buttons	96
4.1.2	DTM or DD – HART and FF.....	96
4.2	Three-Button Operation	97
4.2.1	Three-button operation without display.....	97
4.2.2	Menu Navigation	99
4.2.3	Data Entry	99
4.2.4	Editing a Numeric Value.....	100
4.2.5	Selecting a new setting from a list of choices	100

4.3	The Advanced Display Menu.....	101
4.3.1	Correlation Model Recalculation.....	102
4.4	Monitoring the Advanced Display	120
4.4.1	Advanced Displays	120
4.4.2	Button operation during monitoring	122
4.5	Changing the Failsafe Direction and Write Protect Jumpers (Including Simulation mode).....	123
4.5.1	Procedure to Establish Failsafe Operation.....	123
5	Maintenance	126
5.1	Overview.....	126
5.2	Preventive Maintenance Practices and Schedules	126
5.3	Procedures	129
5.3.1	Output Check Procedures	129
5.3.2	Constant Current Source Mode Procedure	130
5.3.3	Replacing the Terminal Block.....	131
5.3.4	Replacing the Display Assembly	131
5.3.5	Replacing the Communication Module.....	131
5.4	How to replace the Sensor Housing.....	132
5.4.1	Tools required.....	134
5.4.2	Hazardous Locations	140
5.4.3	Appendix: Reconciling Model Numbers.....	140
5.5	Replacing the Wire Probe.....	142
5.5.1	Tools required.....	142
5.5.2	Procedures	143
5.6	Trimming Coaxial Probes	147
5.6.1	Tools required.....	147
5.6.2	Procedure	147
5.7	Saturated Steam Probe Installation.....	150
5.7.1	Tools required.....	150
5.7.2	Procedure	150
6	Troubleshooting	154
6.1	Error Messages	154
6.1.1	Diagnostics	154
6.2	Diagnosing SLG720 Coaxial Probe misassembly.....	157
7	Parts List.....	161
7.1	Overview.....	161
8	Glossary.....	162

9	Appendix Certifications.....	165
9.1	Safety Instrumented Systems (SIS) Installations.....	165
9.2	European Directive Information (EU)	165
9.3	Hazardous Locations Certifications.....	166
9.4	Marking ATEX Directive	171
9.5	Conditions of Use for Ex Equipment, "Hazardous Location Equipment" or "Schedule of Limitations"	172
9.6	Control Drawing.....	174
9.7	China RoHS	178
10	Security	179
10.1	How to report a security vulnerability	179

List of Figures

Figure 2-1: Components of the Level transmitter	2
Figure 2-2: Example of HART connection RL	7
Figure 2-3: Example of FF connection	8
Figure 2-4: Example of a FF network	11
Figure 2-5: Transmitter nameplate example	12
Figure 2-6: Standard SLG 700 Model Number.....	13
Figure 2-7: Safety certification example	13
Figure 2-1: GWR measurement	16
Figure 2-2: Sample Echo Curve	17
Figure 2-3: Interface measurement	18
Figure 2-4 Radar Impulse Reflection model.....	19
Figure 2-5: Upper transition zone length and minimum blocking distance high (BDH) and minimum blocking distance low (BDL) for coax probes in water.....	23
Figure 2-6: Upper transition zone length and minimum blocking distance high (BDH) and minimum blocking distance low (BDL) for coax probes in oil.....	23
Figure 2-7: Transition zone lengths and minimum blocking distance high (BDH) for single lead probes in water.	24
Figure 2-8: Transition zone lengths and minimum blocking distance high (BDH) for single lead (i.e. rod and rope) probes in oil.....	25
Figure 2-9 Minimum blocking distances, steam application for a threaded HTHP process connector	25
Figure 2-10 Minimum blocking distance, steam application for a flanged HTHP process connector ..	26
Figure 2-11: Two-liquids Flooded.....	28
Figure 2-12: Two-liquids non-flooded.....	29
Figure 2-13 Typical Echo steam application echo with vapor reference rod.....	31
Figure 2-14: Top vertical and angled mounting.....	33
Figure 3-1 SLG720 probe dimensions, mm [in].....	40
Figure 3-2: SLG720 FEP probe dimensions, mm [in].....	41
Figure 3-3: SLG726 Threaded process connection probe dimensions; mm [in].....	42
Figure 3-4 SLG726 Flanged process connection probe dimensions; mm [in]	43
Figure 3-5: SLG726 Saturated steam application threaded process connection probe dimensions; mm [in]	44
Figure 3-6: SLG726 Saturated steam application flanged process connection probe dimensions; mm [in]	44
Figure 3-7: Example bending torque values.....	47
Figure 3-8: Drill 6-mm diameter hole at the position shown on the coaxial outer conductor.	48
Figure 3-9: Rod probe assembly	49
Figure 3-10: SLG726 flanged process connection, probe nut installation position, mm [in]	50
Figure 3-11: Wire probe assembly	51
Figure 3-12: SLG720 Coaxial probe assembly (single outer tube depicted)	54
Figure 3-13: SLG720 Coaxial probe assembly (single outer tube depicted)	54
Figure 3-14: SLG726 Coaxial probe assembly	59

Figure 3-15 Saturated steam application rod probe assembly	60
Figure 3-16: Saturated steam application coaxial probe assembly	60
Figure 3-17: Recommended location of holes for rod probes.....	63
Figure 3-18: Centering disks for wire and rod probes.....	64
Figure 3-19: Centering disks for FEP coated wire and rod probes.....	64
Figure 3-20: Probe length definition for rod probes using a centering disk	67
Figure 3-21: Flanged SLG720 Transmitter, mm [in]	67
Figure 3-22: Threaded (NPT ¾", 1", 1½", 2") SLG720 Transmitter, mm [in].....	68
Figure 3-23: Threaded (BSP/G ¾", 1", 1½") SLG720 Transmitter, mm [in].....	69
Figure 3-24: Flanged SLG726 transmitter, mm [in]	70
Figure 3-25: Threaded (NPT 1½", 2") SLG726 transmitter, mm [in].....	71
Figure 3-26: Threaded (BSP/G 1½") SLG726 transmitter, mm [in]	72
Figure 3-27: Mounting position	73
Figure 3-28: SLG720 temperature limits.....	75
Figure 3-29: SLG726 temperature limits.....	76
Figure 3-30: SLG726 Maximum pressure based on maximum operating temperature.....	76
Figure 3-31: Flanged tank connection	78
Figure 3-32: Flange mounting.....	79
Figure 3-33: Oversized nozzle configuration	80
Figure 3-34: Threaded tank connection.....	81
Figure 3-35: Tank roof mounting using threaded connection	81
Figure 3-36: Bypass installation.....	82
Figure 3-37: Mounting on a non-metallic vessel	83
Figure 3-38: Mounting in concrete silos	84
Figure 3-39: Remote mount	85
Figure 3-40: Rotate transmitter housing	86
Figure 3-41: Anchoring wire probes.....	87
Figure 3-42: Wire probe slack.....	87
Figure 3-43: Anchoring coaxial probes	88
Figure 3-44: Transmitter operating ranges	91
Figure 3-45: HART 3-Screw Terminal Board and Grounding Screw.....	93
Figure 4-1: Three-Button Option	98
Figure 4-2: Advanced Display Formats with the Process Variable.....	120
Figure 4-3: Locating the Failsafe and Write Protect Jumpers.....	124
Figure 5-1: Current Loop Test Connections.....	130
Figure 5-2: Electronic Housing Components	131
Figure 5-3: Sensor Housing	132
Figure 5-45-5: Part Number and Date Code (D/C) label on bottom of Terminal PCBA assembly	134
Figure 5-6: Location of sensor housing and attachment set screws	135
Figure 5-7: Communications Housing Assembly	136

Figure 5-8: Rook Assembly	137
Figure 5-9: - Sensor ribbon cable	138
Figure 5-10: Location of RF-connector at bottom of sensor housing	139
Figure 5-11- Model Number Mismatch Critical Error	141
Figure 5-12 - Reconcile Model Numbers feature	141
Figure 5-13 - No Trimming Zones on Outer Tube and Inner Rod	148
Figure 5-14 - Drill Hole Position on Outer Tube	149
Figure 5-15 - Spacer and Locking Pin Installation.....	149
Figure 5-16 - SLG726 flanged process connection, probe nut installation position, mm [in]	151
Figure 5-17 - Saturated steam application rod probe assembly	152
Figure 5-18 - Saturated steam application coaxial probe assembly	153

List of Tables

Table 2-1: Features and Options	1
Table 2-2: Available SmartLine GWR display characteristics.....	3
Table 2-3: Probe Selection.....	4
Table 2-1: Blocking Distance High.....	26
Table 3-1: Installation sequence	36
Table 3-2: Mechanical installation sequence.....	38
Table 3-3: Sensor Details – All Models.....	39
Table 3-4: Minimum blocking distances and transition zones for the various probe types.	39
Table 3-5: Minimum blocking distances and Minimum distance to inlet or surface with DC corrected level for the Saturated Steam Application.....	39
Table 3-6: Maximum measurement range for each probe type versus dielectric constant.	39
Table 3-7: Tensile load limits for flexible probe.....	45
Table 3-8: Rigid (i.e. rod and coaxial) probe mounting angle limits.....	45
Table 3-9: Rod probe bending torque limits (all lengths)	45
Table 3-10: Coaxial probe bending load limits (all lengths)	45
Table 3-11: Recommended probe diameter and material of construction.....	61
Table 3-12: Centering disk determination from pipe size and schedule.....	65
Table 3-13: Centering disk dimensions.....	65
Table 3-14: Probe length for different probe types	66
Table 3-15: Minimum recommended distance to container wall and obstacles (mm).....	73
Table 3-16: SLG726 Maximum pressure based on maximum operating temperature in tabular form	77
Table 3-17: SLG720: Recommended nozzle dimensions	79
Table 3-18: SLG720 bypass and stillwell recommended diameters.....	82
Table 3-19: SLG726 bypass and stillwell recommended diameters.....	83
Table 3-20: Conduit entry plug installation.....	89
Table 3-21: Conduit adapter installation	89
Table 4-1: Three-Button Option Functions.....	99
Table 4-2: Three-Button Data Entry.....	100
Table 4-3: Advanced Display Main Menu Structure	101
Table 4-4: Correlation Model Recalculation.....	102
Table 4-5: Display Config sub-menu.....	103
Table 4-6: Basic Configuration sub-menu.....	105
Table 4-7: Advanced Config sub-menu	109
Table 4-8: Monitor sub-menu.....	114

Table 4-9: Advanced Displays with PV Format Display Indications.....	121
Table 4-10: HART Failsafe and Write Protect Jumpers	125
Table 4-11: FOUNDATION Fieldbus Simulation and Write Protect Jumpers	125
Table 5-1: Probe length calculated from spare probe model number.	145
Table 6-1: SLG 700 Standard Diagnostics Messages	155
Table 7-1: Parts	161

This page has been intentionally left blank

1 Introduction

1.1 Overview

The SLG 700 Guided Wave Radar SmartLine transmitter is an electronic instrument designed to measure levels of liquid and solid materials. Guided Wave Radar (GWR) transmitters use time domain reflectometry with radar pulses guided by a metal probe and reflected off a product surface to determine levels in tanks. In comparison to other level measurement technologies, GWR provides a highly-accurate, cost-effective, reliable measurement over a wide range of process conditions.

1.2 Transmitter Models

The SmartLine Guided Wave Radar (GWR) transmitter is available as a family of SLG72X models for liquid applications. The pressure and temperature application ranges for each model are summarized in [Table 2-1](#).

Table 2-1: Features and Options

Range	Model
Standard Temperature Liquid Level Measurement (-40 to 200°C/-1 to 40 bar)	SLG720
High Temperature / High Pressure Liquid Level Measurement (-60 to 450°C /-1 to 400 bar)	SLG726

Each model is available with a range of probes, wetted materials, and accessories to suit most applications.

1.3 Transmitter Components

1.3.1 Overview of components

As shown in

[Figure 2-1](#) the transmitter consists of:

- Electronics housing containing
 - Display module (optional)
 - Buttons module (optional)
 - Communications module
 - Electrical terminal block assembly
- Sensor housing
- Process connector
- Probe, also known as a waveguide

These components are described below.

Additional mounting and optional accessories are available, such as centering discs for probes. For list of all options and accessories please refer to the purchasing specifications, which is available, here: <https://www.honeywellprocess.com/en-US/explore/products/instrumentation/process-level-sensors/Pages/smartline-level-transmitter.aspx>.

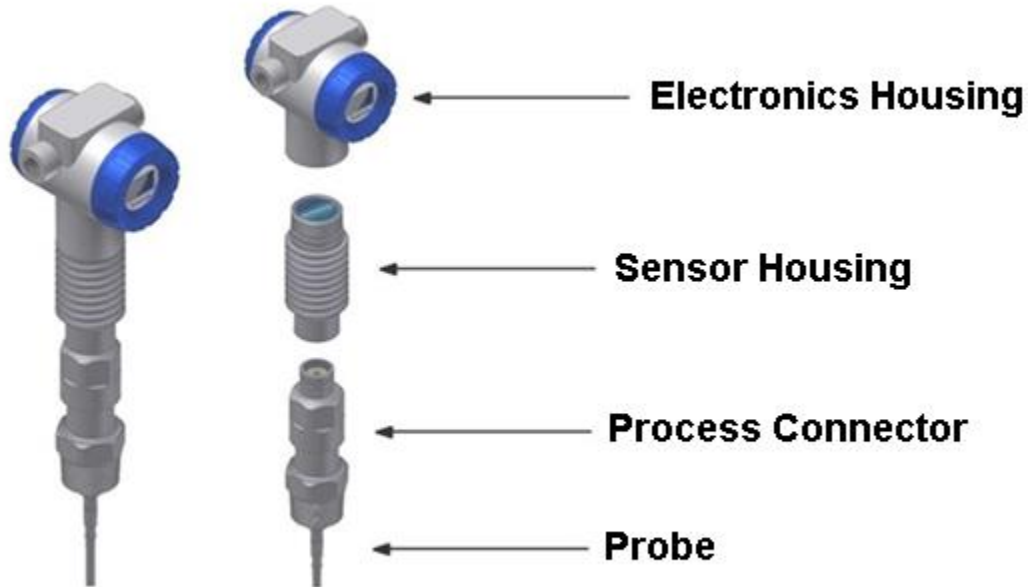

Figure 2-1: Components of the Level transmitter

1.3.2 Electronics Housing

The Electronics Housing contains these components. All components are replaceable in the field.

Terminal Assembly: Provides connection points for the measurement signal and power. Different terminal modules are required for HART[®] and FOUNDATION[™] Fieldbus versions of the transmitters. The terminal is polarity insensitive. Lightning protection is optional.

Communications module: The platform provides separate electronics modules for HART[®] and FOUNDATION[™] Fieldbus versions of the transmitters. The communication board for a certain communication protocol always requires terminal assembly for the same type of communication. Descriptions of the communications protocols are in the Glossary.

Optional Display: [Table 2-2](#) lists features of the available display module.

Optional Buttons: Refer to [Figure 4-1: Three-Button Option](#) for more information.

Table 2-2: Available SmartLine GWR display characteristics

Advanced Display	<ul style="list-style-type: none">• 360° rotation in 90° increments• Three configurable screen formats with configurable rotation timing<ul style="list-style-type: none">○ Large process variable (PV)○ PV with bar graph○ PV with trend (1-999hrs, configurable)• Echo stem plot for checking measurement accuracy• Eight Screens with 3-30 sec. rotation timing and the use of 3-buttons for configuration.• Standard and custom engineering units• Diagnostic alerts and diagnostic messaging• Multiple language support options:<ul style="list-style-type: none">○ Option 1: EN, FR, GE, SP, RU, TU, IT○ Option 2: EN, CH, JP (Kanji)• Supports 3-button configuration and calibration• Supports transmitter messaging and maintenance mode indications
------------------	---

To make changes to the transmitter setup or configuration without the use of an external device such as a handheld or PC, an optional 3-Button Assembly is available. Use the buttons and menus to:

- Configure transmitter
- Configure and navigate displays

1.3.3 Sensor Housing

The sensor housing contains the pulse generation and analysis hardware. These electronics are potted to provide flame path resistance. The sensor housing is available as a replaceable part.

1.3.4 Process Connector

The process connector has the following functions.

- Separates the process environment from the external environment.
- Provides a threaded insert to the tank which removes the need for brackets to mount the transmitter. Various mounting types are available, including popular threads and flanges.
- Provides electrical feed-through to the probe.

Each of the SLG720 and SLG726 models have different process connector designs.

Note:

Each process connector design accepts a sub-set of the full range of probe types.

1.3.5 Probe



The purpose of a Guided Wave Radar probe is to guide radar pulses produced by the radar transmitter towards the material being measured. It also guides the reflected pulse back to the transmitter for processing into a level measurement. The probe can be made of a single conductor such as for single wire or rod probes, or two conductors for coaxial probes. For rigid probes (rod and coaxial), multiple segments, each up to 2m long, can be connected.



















The probe is also known in the industry as “waveguide”.

A single wire probe is the most common design; other designs are provided based on application needs. For the purposes of this document the term “Wire” is being used, however the term “Wire” and “Rope” are interchangeable.

Table 2-3 summarizes advantages and disadvantages of different probe constructions. Installation details of each probe are described in Chapter 3.

Table 2-3: Probe Selection

Legend	
	Yes
	No
	Contact the TAC team

	Single wire (Wire)	Single rod	Coaxial
			
Level			
Interface (liquid/liquid)			
Bubbling/boiling surfaces			
Low-dielectric constant liquids ¹			
Foam (liquid surface measurement)			

Foam (top of foam measurement)	☎	☎	✘
Foam (top of foam and liquid surface measurement)	☎	☎	✘
Coating/tacky liquids	☎	☎	✘
Crystallizing liquids	☎	☎	✘
Viscous liquids	☎	☎	✘
Probe is close to tank wall/disturbing objects (<12"/30cm)	☎	☎	✓
Probe could contact tank wall, nozzle or disturbing objects	✘	✘	✓
Turbulent Surface	☎	✓	✓
Turbulent fluid causing mechanical stress on probe	✘	☎	✘
Tall, narrow nozzles ¹	☎	☎	✓
Liquid or vapor spray could contact probe above surface	✘	✘	✓
Disturbing electromagnetic interference in tank	☎	☎	✓
Ability to clean probe	✓	✓	✘

¹ See the *SLG 700 SmartLine Guided-Wave Radar Level Specification*, Document #34-SL-03-03.

1.4 Communicating with the Transmitter

It is possible to remotely monitor and configure a transmitter using either the HART® or FOUNDATION™ Fieldbus (FF) protocols. Alternatively, with the HART® option, the transmitter can be monitored using the analog current, and with both interfaces, can be configured using the three-button interface and display.

Note: The protocols are not interchangeable. Each protocol uses significantly different terminal and communication boards that are installed before shipping.

1.4.1 4-20 mA HART®

The output of a transmitter configured for the HART protocol includes two primary modes:

- **Point-to-Point Mode:** one transmitter is connected via a two-conductor, 4-20mA current loop to one receiver.
- **Multi-Drop Mode:** several transmitters are connected through a two-conductor network to a multiplexed receiver device.

The major difference between the two modes is that in Point-to-Point mode, the average value of the loop current represents the current value of an analog signal representing the process inside the tank. In multi-drop mode, the average value of the loop current is fixed, usually at 4mA. Therefore, in Point-to-Point mode, an external control system can read the Primary Variable (PV) through an analog input without HART messaging, whereas in multi-drop mode, the PV can only be read as a digital value using HART messaging.

Note: In the HART system, the abbreviation PV is used to denote the Primary Variable which may be only one of a number of process or device variables that may be available.

SLG 700 supports HART version 7 and its associated backward compatibility. The analog signal is modulated by Frequency Shift Keying (FSK), using frequencies and current amplitude that do not affect analog sensing at the receiver. The accuracy of the analog level must be precisely controlled for accurate sensing. HART communication will not *bump* process variables. In multi-drop mode, theoretically up to 16 devices in HART 5 (addresses 0-15) or up to 64 devices in HART6/7 (addresses 0-63) can exist on the two-conductor network. Practically, the number of devices in a multi-drop installation is limited due to design constraints. When installing into a multi-drop network, consider that the SLG700 requires a minimum startup current of 17mA and a minimum terminal voltage of 11V during startup. After this initial startup period (approximately 0.5 seconds), the loop current will be fixed at 4mA, and the minimum terminal voltage is 14V. The power source, wiring, intrinsic safety barriers, and other devices in the network be considered to ensure these requirements can be met.

Note: The SLG700 requires a minimum startup current of 17mA, even when configured in multi-drop mode. The minimum terminal voltage is 11V during startup. After startup, the loop current will be fixed at 4mA, and the minimum terminal voltage should be 14V.

Figure 2-2 is an example of a HART connection to the transmitter. The communication resistor RL may be inserted anywhere in the 4-20 mA loop but it is recommended to be installed close to the positive supply. Refer to section 0 for acceptable power supply and RL ranges

The MC Toolkit is a dedicated Honeywell communication tool that uses Device Description (DD) files to communicate with multiple transmitter models. Also, other equivalent tools or a HART-to-USB converter may be used. Device Description files are available from:

- HONEYWELL: Go to:

<https://www.honeywellprocess.com/en-US/explore/products/instrumentation/process-level-sensors/Pages/smartline-level-transmitter.aspx>

Select the “Software” tab.

Scroll/search for file name:

“HART Device Description (DD) files for Honeywell HART Devices”

This .zip file contains the latest version of the DD files for all of Honeywell’s HART field devices.

Unzip the file to locate the DD files applicable to the SLG 700 series.

- HART® FOUNDATION: <http://en.hartcomm.org>

Note:

Device Descriptions (DD) are HART data files which are gathered from field device manufacturers which describes the features and functions of a device.

HART provides a detailed definition here: <http://en.hartcomm.org/hcp/tech/faq/faq.html>

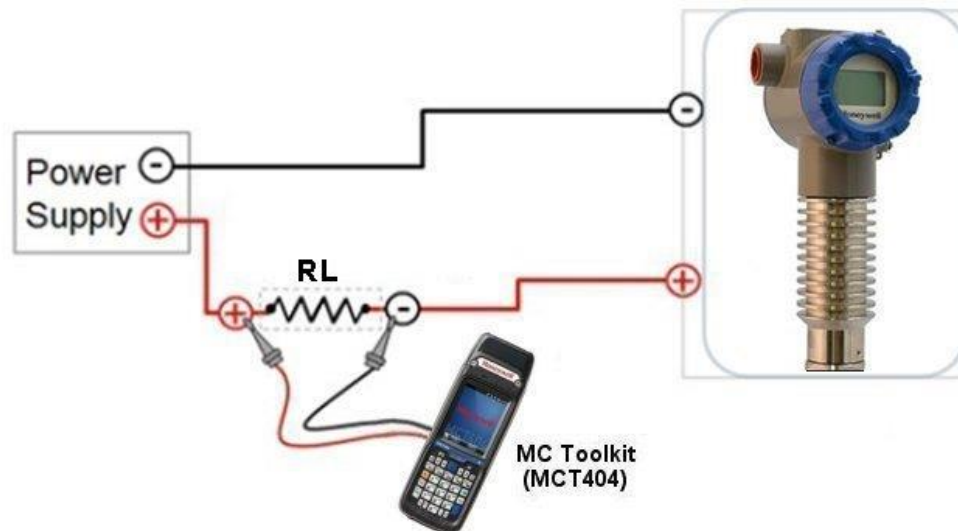

Figure 2-2: Example of HART connection RL

Refer to section 0 for RL information

1.4.2 FOUNDATION™ Fieldbus (FF)

The Honeywell SLG 700 is a SmartLine Level transmitter that has a wide range of additional features along with supporting the FOUNDATION™ Fieldbus (FF) communication protocol. The SLG 700 level transmitter with FF protocol provides a FOUNDATION Fieldbus interface to operate in a compatible distributed Fieldbus system. The transmitter includes FOUNDATION Fieldbus electronics for operating in a 31.25 Kbit/s Fieldbus network and can interoperate with any FOUNDATION Fieldbus registered device.

The Honeywell SmartLine SLG 700 is a high-performance transmitter offering high accuracy, reliability and resolution over a wide range of process conditions.

The SLG 700 Fieldbus device is fully tested and compliant with Honeywell Experion® PKS providing the highest level of compatibility assurance and integration capabilities.

Figure 2-3 graphically represents the connection of the transmitter to a FF handheld device. A similar connection may be realized using PC configuration software.

Each transmitter includes a configuration database that stores its operating characteristics in a non-volatile memory.

The handheld or PC software is used to establish and/or change selected operating parameters in a transmitter database. The process of viewing and/or changing database parameters is called configuration.

Configuration can be accomplished both online and offline with the transmitter powered up and connected to the handheld.

Online configuration immediately changes the transmitter operating parameters. For offline configuration, transmitter operating characteristics are entered into the handheld memory for subsequent downloading to transmitter.

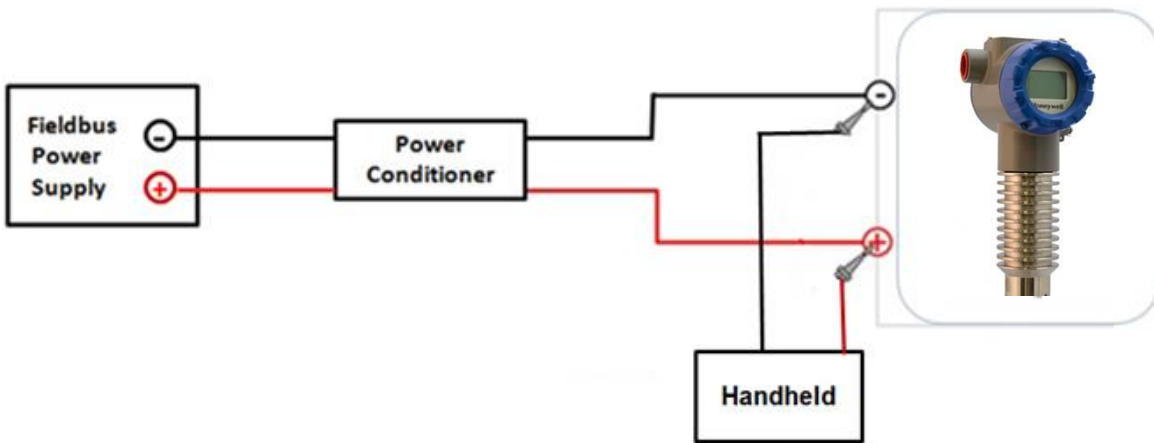

Figure 2-3: Example of FF connection

1.4.3 DTM-based tools and Experion

HART and FOUNDATION Fieldbus models support Device Type Managers (DTMs) running on Field Device Technology[®] (FDT) hosts such as PACTware or Field Device Manager (FDM) / Experion.

The transmitter establishes communication with the host systems using DD or DTM.

Device Description (DD)

DD is a binary file that provides the definition for parameters in the FBAP of the transmitter. For example, DD refers to the function blocks that a transmitter contains, and the corresponding parameters in the blocks that are critical to the interoperability of Fieldbus devices. They define the data required to establish communications between different Fieldbus devices from multiple vendors with control system hosts. The DD provides an extended description of each object in the Virtual Field Device (VFD).

The Fieldbus Foundation provides the DD for all registered devices on its website, http://www.fieldbus.org/index.php?option=com_mtree&task=viewlink&link_id=1991&fbstatus=Registered&Itemid=324

Enhanced Device Description (EDD)

There are two types of EDDs available, namely .ff5/.sy5 and .ffo/.sym. The .ffo/.sym binary files are generated for the legacy hosts to load the device DD that is generated using latest tokenizer. Few constructs like Images that are supported in .ff5/.sy5 binaries, are not supported in .ffo/.sym binary files.

Device Type Manager (DTM)

The DTM is similar to a device driver that enables usage of devices in all the asset management and device configuration software like FDM or PACTware, with the help of the FDT-DTM technology.

The DTM has the following primary functions:

- Provides a graphic user interface for device configuration.
- Provides device configuration, calibration, and management features for the particular device.

The DTM provides functions for accessing device parameters, configuring and operating the devices, calibrating, and diagnosing problems.

Download the DTM from: <https://www.honeywellprocess.com/en-US/explore/products/instrumentation/process-level-sensors/Pages/smartline-level-transmitter.aspx>

Go to the Software tab

To set up the DTM on the FDM/Experion refer to the *FDM/Experion User Guide*.

[Figure 2-4](#) shows an example of a FF network setup.

For more information on Experion go to:

<https://www.honeywellprocess.com/integrated-control-and-safety-systems/experion-pks/>

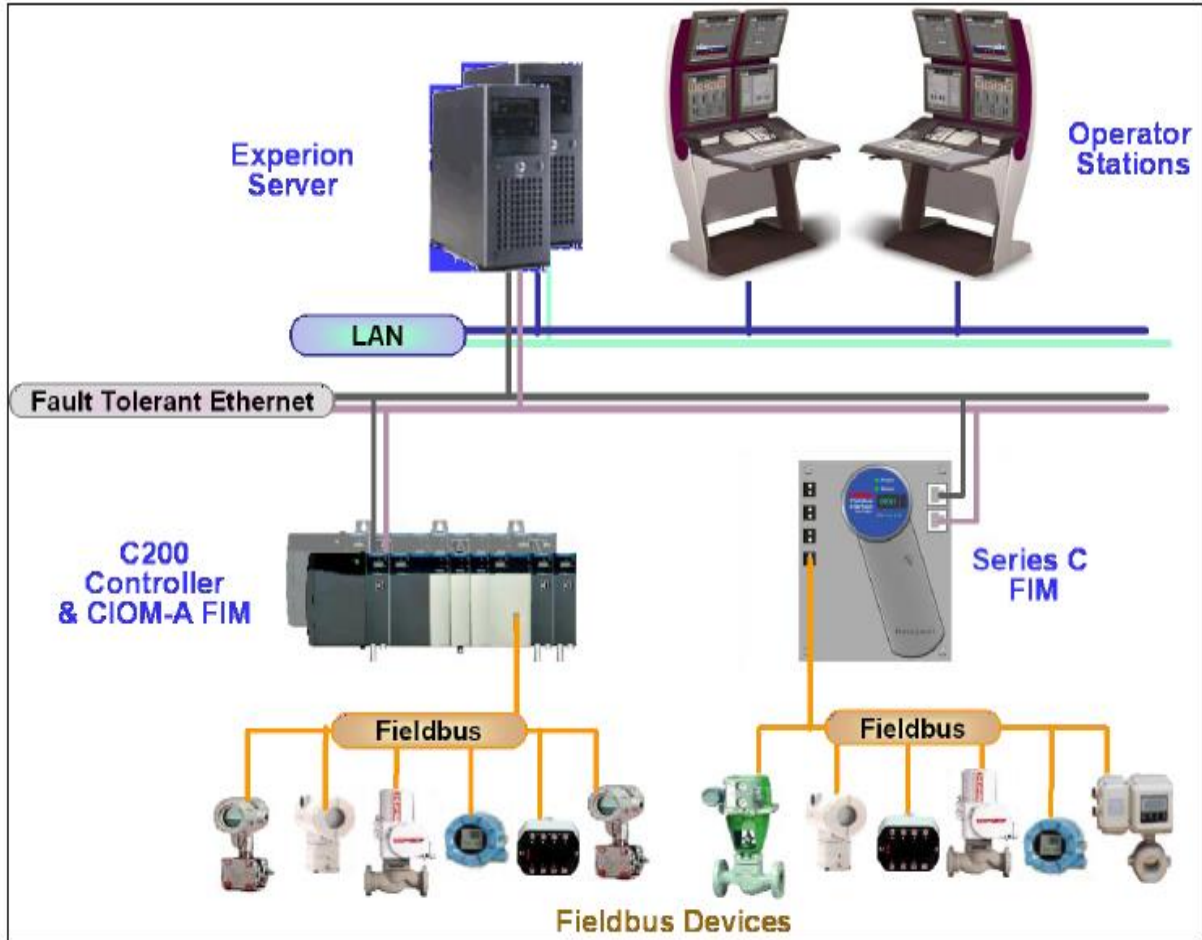

Figure 2-4: Example of a FF network

1.5 SLG 700 Transmitter nameplate

The Transmitter nameplate is mounted on the top of the electronics housing (see [Figure 2-5](#)) and lists the following properties:

- Model number
- Physical configuration
- Power supply voltage
- Maximum working pressure rating
- Certification, if ordered (SIL and CRN)

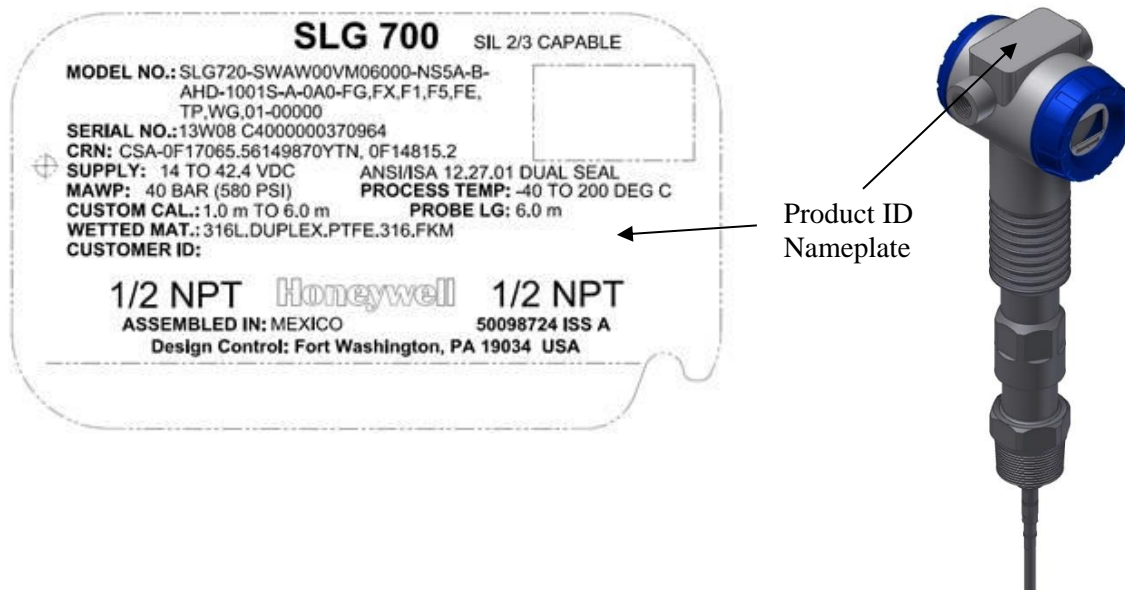

Figure 2-5: Transmitter nameplate example

The nameplate contains the following information:

MODEL NO.: The transmitter model number per the model selection guide.

SERIAL NO.: The unique transmitter serial number.

CRN: The CSA Registration number.

SUPPLY: The DC power supply voltage range as measured at the terminal assembly.

MAWP: Maximum Allowable Working Pressure.

PROCESS TEMPERATURE: The Process temperature range.

CUST. CAL.: Specifies any custom calibration, if ordered, otherwise blank.

PROBE LG: Length of the probe as defined in the model number.

WETTED MATERIAL: A list of the wetted materials.

CUSTOMER ID: User-defined identifier, if ordered, otherwise blank.

HOUSING CONNECTION TYPE: Conduit fitting size: ½” NPT or M20

ASSEMBLED IN / MADE BY HONEYWELL: The country where the transmitter was assembled and tested.

SIL INFORMATION: SIL 2/3 Capable is indicated if SIL certification applies, otherwise blank.

COMMUNICATION INTERFACE: A symbol indicating the supplied communications interface, HART or FOUNDATION Fieldbus.



1.6 Transmitter Model Number Description

The model number is comprised from a number of selections and options that can be specified when ordering the transmitter. It includes a basic transmitter type such as **SLG720** (standard temperature, standard pressure) followed by a maximum of nine additional character strings that can be selected from a corresponding Table in the Model Selection Guide (MSG).

The basic model number structure is shown in Figure 2-6.

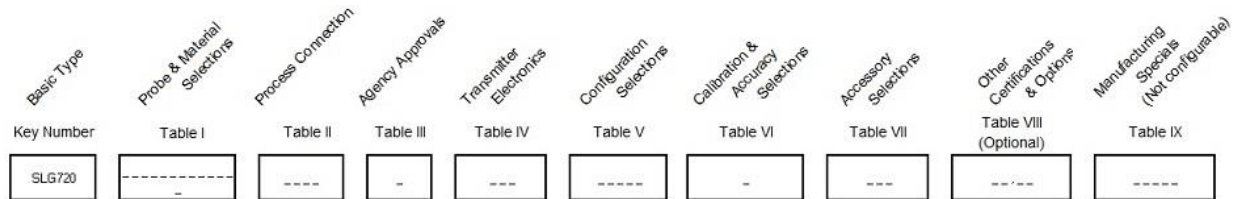

Figure 2-6: Standard SLG 700 Model Number

For a more complete description of the various configuration items and options, refer to the *SLG 700 Product Specification (34-SL-03-03)* and Model Selection Guide (34-SL-16-01).

1.7 Safety Certification Information

SLG transmitter models are available for use in hazardous locations, including CSA, IECEx, ATEX, and FM approvals. See Appendix Certifications for details and other approvals. The transmitter will include an “approvals” nameplate mounted on the electronics housing with the necessary compliance information.

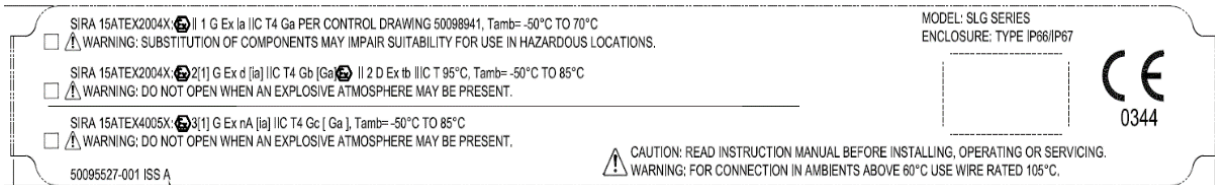

Figure 2-7: Safety certification example

1.7.1 Safety Integrity Level (SIL)

The SLG 700 is intended to achieve sufficient integrity against systematic errors by the manufacturer’s design. A Safety Instrumented Function (SIF) designed with this product must not be used at a SIL level higher than the statement, without “prior use” justification by the end user or diverse technology redundancy in the design. Refer to the *SLG 700 Safety Manual*, Document #34-SL-25-05, for additional information. The SIL level will be indicated on the SLG 700 nameplate.

See the SLG 700 Transmitter nameplate for additional information, Figure 2-5.

1.8 Security Considerations

The SLG 700 provides several features designed to prevent accidental changes to the device configuration or calibration data. These features include a local display password (HART option), a communication password (HART option), a Hardware Write Protect Jumper and a Software Write Protect configuration parameter. These features can be used in combination to provide multiple layers of change protection.

For both the local display and communication passwords, the initial user passwords are defined as "0000". A "0000" password indicates that the user has not set a user-defined password and the password protection is disabled. The password used on the local keyboard display is separate from the password provided for communication. Password protection from the local keyboard display does not inhibit changes by way of communication over the current loop. A master password is available that allows recovery if the set user password is unknown.

A hardware write-protect locks out changes regardless of the entry of a password. The hardware jumper requires physical access to the device as well as partial disassembly and should not be modified where the electronics are exposed to harsh conditions or where unsafe conditions exist. For configuration or calibration changes without changing the hardware jumper position the user may choose to rely on the password and software lockout features.

A tamper mode feature (see *SLG 700 SmartLine Guided Wave Radar Level Transmitter HART Option Manual*, Document #34-SL-25-06) is available that can indicate that an attempt was made to change either the configuration or calibration of the device (whether or not a change was actually made). These security features are designed to avoid accidental changes and to provide a means to detect if an attempt was made to change the configuration and calibration. Note: FF does not support tamper mode.

1.9 Measurement Options Licensing

As of software revision R200, the sensor checks whether the user has a license required to operate the device in a particular measurement mode (see also 2.5 for the various measurement modes). Licenses are required to measure two-liquid interfaces, use the low DC measurement mode and for steam applications. Any sensor ordered for these application will have a valid license key stored in the transmitter and no user action is required.

The license key depends on the device ID which can be checked using the display (see Table 4-8 or DTM). It is possible to obtain new license keys for application types other than which the gauge was originally bought for by supplying the device ID to Honeywell and entering the newly obtained license key.

Gauges that were installed prior to R200 do not lose access to the interface measurement when they are upgraded to the new software - the sensor will internally generate a license key for this application after the first startup and store it in memory.

2 Radar Level Measurement

2.1 Overview

This chapter describes the theory of operation of the transmitter and discusses how measurements are affected by tank and process conditions.

2.2 Theory of Operation

Guided wave radar provides level measurement based on the Time-Domain Reflectometry (TDR) principle. Electromagnetic measurement pulses are guided to the measured material by a metallic probe. When the pulses reach a product surface or interface, a portion of the pulse will propagate through the surface and the rest will be reflected backwards. The same probe transports the reflected pulses from the measured material back to the transmitter.

The SLG 700 uses many very-low-power pulses with a technique called Equivalent-Time Sampling (ETS) to efficiently extract level information. Figure 2-2 is an example of a waveform acquired with the ETS method. The levels can be extracted from waveforms knowing the expected positions and shapes of the flange, surface or interface, and end of probe reflections.

The electromagnetic measuring signal travels at the speed of light for the medium in which it is propagating in and the probe on which it propagates.

The pulse speed will be less than the speed of light in air by an amount which can be calculated knowing the 'dielectric constant' of the material.

The transmitter measures the time of travel of the reflected signal and calculates distance to the reflection point. The level of the material can be calculated based on the distance from the transmitter to the material and the dimensions of the container as illustrated in [Figure 2-1](#).

Distance to Surface calculation:

$$d_s = \frac{t \times V_{wg}}{2 \times \sqrt{DC_v}}$$

Where:

d_s = Distance to surface

t = time for the pulse to travel distance, d_s

v_{wg} = speed of light in a vacuum on the probe

DC_v = dielectric constant of the material in the head space above the level
(for air, $DC = 1$)

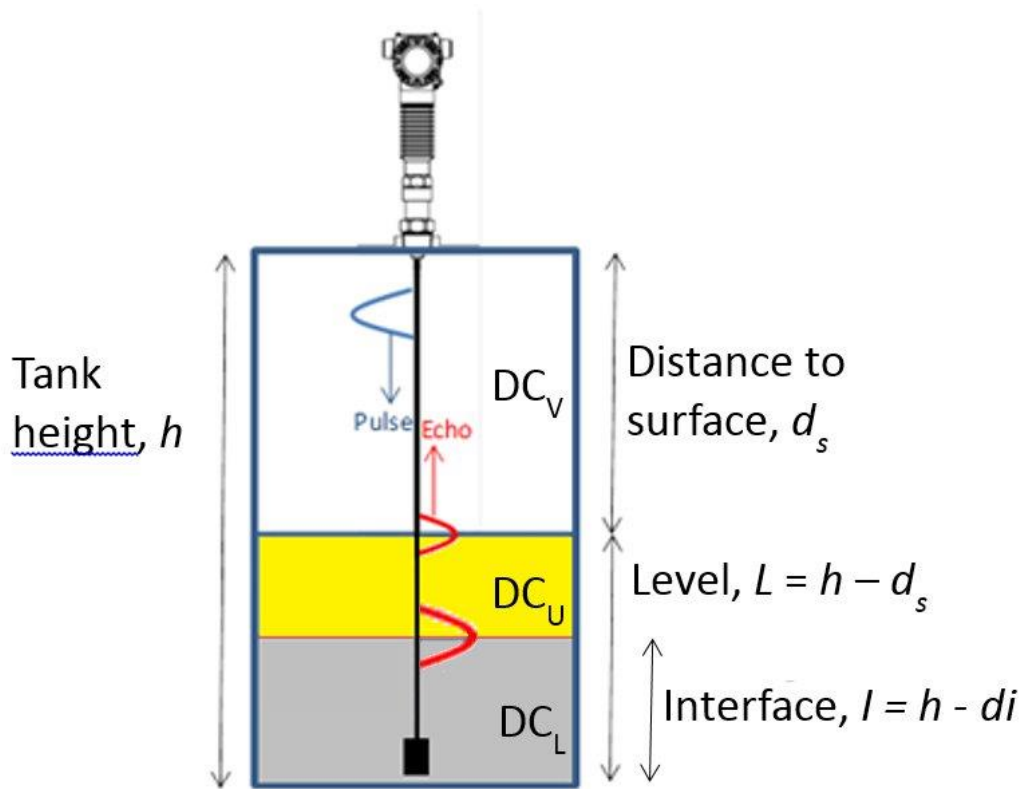

Figure 2-1: GWR measurement

DC_V = Dielectric Constant of Vapor

DC_U = Dielectric Constant of Level (Upper Product)

DC_L = Dielectric Constant of Interface (Lower Product)

2.2.1 TDR for Interface and Flooded Measurements

The Time-Domain Reflectometry (TDR) principle can also be used to measure an Interface Level as well as the upper level. The position of the level interface has to be calculated with knowledge of the dielectric constant (DC_U) of the upper layer.

The SLG 700 can measure levels of different materials in the same tank and can detect the echo from the boundary between Vapor and the Upper Product (UP), and between the Upper Product (UP) and the Lower Product (LP). This allows calculating the level for each material and the interface thickness as in Figure 2-3.

If an interface level is being measured, the pulses pass through the upper medium before reaching the interface.

Distance to Product in the Interface equation:

$$d_I = d_s + \frac{\Delta t \times V_{wg}}{2 \times \sqrt{DC_U}}$$

Where:

d_s = Distance to surface

Δt = change in time for a pulse to travel the distance through the Upper Product

v_{wg} = speed of light in a vacuum on the probe

DC_U = Dielectric Constant of Upper Product

Surface and interface measurements can be made if:

DC_U = where the DC Upper Product is less than 9 and the DC difference between the upper and lower product is greater than 8.

The minimum thickness of the interface layer is 7cm.

Figure 2-2 shows the distances to surface and interface can be calculated as shown in this sample echo curve.

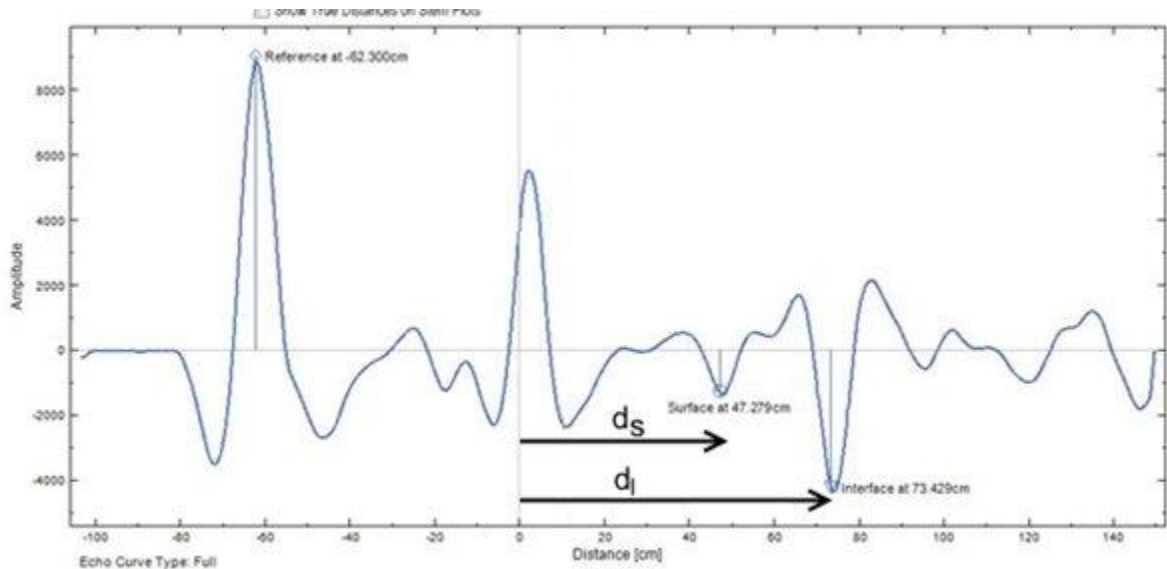

Figure 2-2: Sample Echo Curve

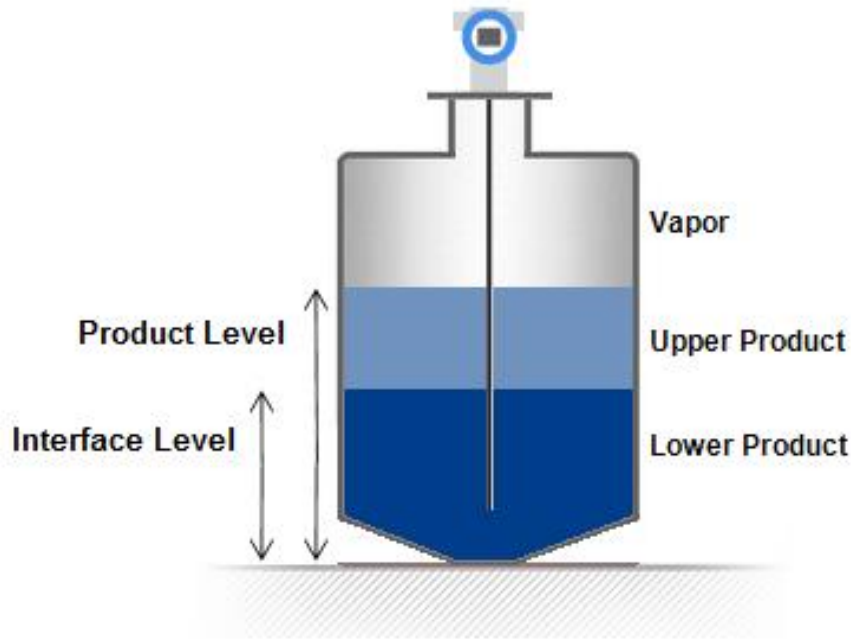

Figure 2-3: Interface measurement

2.3 Signal processing configuration

SLG 700 series level transmitters employ advanced signal processing techniques in order to get the most accurate measurements possible.

Complete pulse-shape information including amplitude, width and side-lobe attenuation is used for level detection in order to minimize the influence of signal interferences. A typical pulse and the associated parameters is shown on Figure 2-4.

The sensor is programmed with default values for all parameters, determined by the dielectric constants of the materials being measured. Either through the advanced display or using the Honeywell DTM (SLG 700 HART option manual 34-SL-25-06) these parameters can be adjusted to match the measurement conditions. Typically, the amplitude (also referred to as gain) of the model is the only parameter that needs to be adjusted, and this is generally only required if the dielectric constant of the medium is uncertain. Note that the ‘attenuation’ parameter of the model should not be confused with the attenuation of the radar pulse as it propagates down the waveguide.

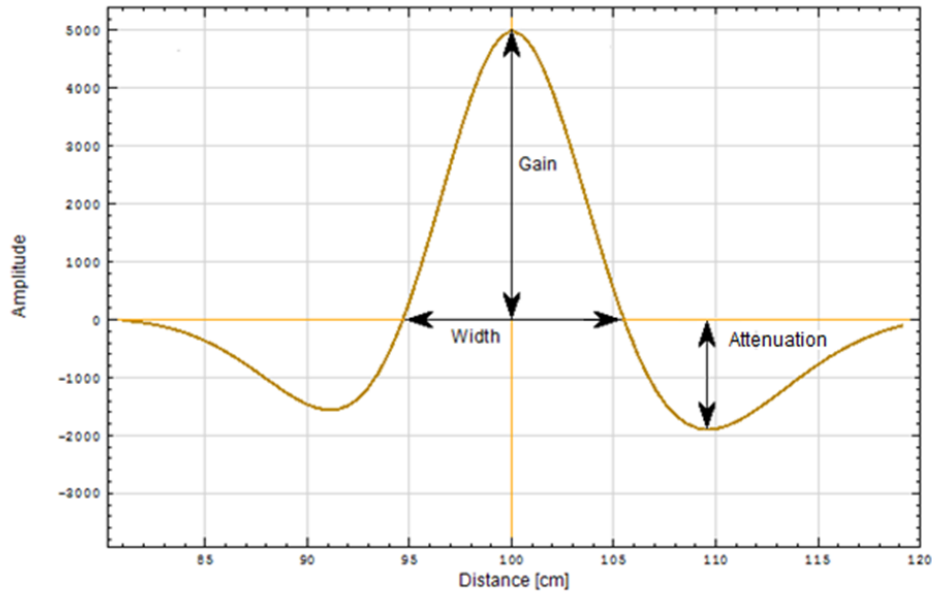

Figure 2-4 Radar Impulse Reflection model

Although the algorithms are tolerant of signal amplitude variation, a good match is important to discern the true level signal from that caused by obstacles near the probe or secondary reflections. Both the DTM and the advanced display module show the signal quality, a measure of the match between radar pulse model and acquired echo curve.

2.3.1 Amplitude Tracking

Release R102 introduced an additional feature to improve level tracking under difficult conditions or when the medium attenuation is not well known. The amplitude tracking feature (off by default) enhances the user specified pulse model information using historical measurement data. It can improve the quality of the match when there are slowly varying conditions in the tanks, such temperature variations, vapor density changed, turbulence or even dirt build up on the probe. Amplitude tracking is not a substitute for model tuning and will not track signals more than 35% different in amplitude from those expected. It should be noted that tracked amplitudes are periodically saved to permanent memory. When the sensor starts up it will first attempt to locate the levels using the tracked signal amplitudes and if this fails, will revert to the initial amplitudes when the sensor loses power since it is impossible to predict whether the conditions that caused the pulse to change (say turbulence) exist when the sensor is repowered.

2.3.2 Full-tank Detection

This feature enables the transmitter to perform additional analysis on the data in the region near the reference plane where the product reflections become mixed with reflections from the physical mounting components such as a flange or nozzle. This additional analysis allows the transmitter to detect the presence of product in this region even if the shape of the product reflections deviate significantly from the expected shape. This option should only be enabled if a recently captured Field or Obstacle background is in use and the Dielectric Constant of the Upper Product is above 12. It should not be enabled for products with low Dielectric Constants or when the Built-in background type is being used.

2.3.3 Maximum Fill Rates, Latching and Timeouts

The maximum fill rate, also referred to as Rate of Change (ROC) limits the expected level changes between two successive measurements. Software revision prior to R200 allowed a range of 4 - 20 cm/s. As of R200 this limit is increased to 90 cm/s. If a level is detected to have moved further than the ROC limit, the level status is considered bad. See also Table 4-5: Display Config sub-menu.

The Echo Lost Timeout setting is the number of seconds that the transmitter will wait after the reflection from the product has been lost before setting a critical alarm and entering failsafe (burnout) mode. The same behavior will result if instead of the measurement being completely lost, the rate of change has been exceeded.

The latching mode parameter allows selecting the behavior of the GWR transmitter in case of a measurement fault critical error. If the Latching option is selected, the GWR transmitter will stay in the critical error state once the Echo Lost Timeout has expired, until a user performs a hardware or software reset. The latching mode option has a significant effect on behavior of the sensor when levels are considered lost. If the Non-latching option is selected, the GWR transmitter will leave the critical error state automatically (after the Echo Lost Timeout expires) and attempt to re-measure level over the entire probe length. Latching mode can only be enabled with HART transmitters.

2.4 Signal Interferences and background echoes

Interfering reflections can occur near the top and bottom of the probe. These interfering echoes occur or when the pulse encounters a transition, such as from nozzle to tank, or when the pulse exits the process connector for a rod or wire probe, or when the pulse is reflected from the end of the probe. Unwanted reflections can also occur, from deposits on the probe or from interfering structures such as inlets, outlets, ladders and so forth, which are positioned near the probe. If the user suspects deposits on the probe then it should be inspected and cleaned, if necessary. The top and bottom zones in which these interferences occur can be configured as blocking distances within which no measurement will occur.

Coaxial probes are less susceptible to these interferences and have smaller upper blocking distances. For all probes, the effects of interfering reflections near the process connector can be reduced by background subtraction.

Release R102 offers two type of background echo acquisition modes and either can be operated statically or dynamically.

Note that the Saturated Steam application is the only one which does not use background subtraction.

2.4.1 Field and Obstacle background

The field background is meant to reduce the effect of the process connector reflection created when the radar pulse traverses between two regions of different impedances. The preset length varies from 1.32m (standard temperature and pressure gauge) to 2.38m (high pressure high temperature model) from the measurement reference plane (bottom of the process connector). The user needs to ensure that the level in the tank is below these values when acquiring the background. The field background is stored in permanent memory and can be displayed using the Honeywell DTM or DD.

The obstacle suppression background can be used in place of the field background and is intended to both suppress process connector reflections as well as any false echoes generated by obstacles in the tank (ladders, pipes, valves) in the vicinity of the probe. There is no limit on the length that can be specified by the user. As with the field background, the level in tank needs to be about 20cm below the end of the requested echo. One difference between the obstacle suppression echo and the field background echo is that the sensor algorithms analyze this echo and store only those sections of the profile that are found to contain false echoes. For example if a ladder exists 2m down a tank and a pipe inlet 19m down the tank, the user should obtain an obstacle echo up to approximately 20m. The sensor will automatically detect the two objects and permanently store the relevant data.

2.4.2 Static and Dynamic backgrounds

Release R102 introduced automatically updated background profiles. The intent of this feature is to provide enhanced immunity against measurement conditions. With dynamic backgrounds on, the sensor periodically schedules automatic updates to the background. Echoes are only collected if the level is outside of the transition zones and the signal is of good quality. Data is collected up to approximately 20 cm from the level at the time, if this distance is within the requested background echo length.

The most recently updated background is also stored in permanent memory and is applied after a sensor reset if dynamic background is enabled. At all times the sensor maintains a copy of the original user-acquired (static) background echo and will revert to this if the dynamic background feature is once again disabled. Re-enabling dynamic background at that point starts the process anew. It is recommended that this feature is turned on in all installations where build-up or ambient temperature swings over approximately 30°C (55°F) are expected.

2.4.3 Accuracy and measurement range specifications

The available probe lengths for each probe type are summarized in **Error! Reference source not found.**

These accuracy specifications are defined under reference conditions, at other ambient temperatures the accuracy specifications are increased by $\pm 0.2 \text{ mm}/^\circ\text{C}$ or $\pm 15 \text{ ppm}/^\circ\text{C}$ whichever is greater.

The measurement accuracy over the probe length is the larger of $\pm 3\text{mm}$ or $\pm 0.03\%$ of probe length. At the top and bottom of the probe the measurement performance can deviate from the $\pm 3\text{mm}$ or $\pm 0.03\%$ accuracy specification.

The zones at the top and the bottom of the probe at which the accuracy deviates from the accuracy spec is called upper and lower transition zones respectively.

As the level rises or falls in the upper and lower transition zone a point may be reached where the transmitter cannot provide a level reading or the accuracy is worse than $\pm 30\text{mm}$, at this point we have reached the minimum blocking distance that can be set in the transmitter.

Figure 2-7 to Figure 2-6 summarize the accuracy as a function of length for the available probe types in addition Table 3-4 provides a tabular summary of the minimum blocking distances and the transition zones. To meet the accuracy specifications near the end of the probe (lower transition zone and minimum blocking distance low), the correct probe type and probe length need to be configured.

Note that for a wire probe with an end weight or with a looped end the minimum blocking distance low is measured from the top of the weight or the top of the loop's crimp.

When the transmitter is installed in a nozzle then the distances are measured from the bottom on the nozzle, i.e. where the nozzle transitions to the tank. In addition, when using a nozzle the guidance provided in Section 3.2.9.2 needs to be followed.

For the following four figures in this section, T_{up} and T_{low} are upper and lower transition zones respectively.

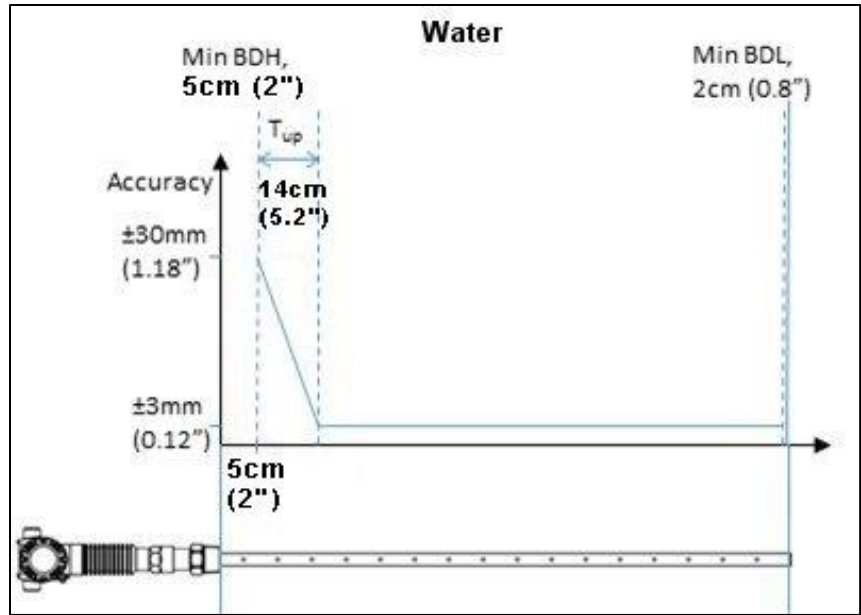

Figure 2-5: Upper transition zone length and minimum blocking distance high (BDH) and minimum blocking distance low (BDL) for coax probes in water.

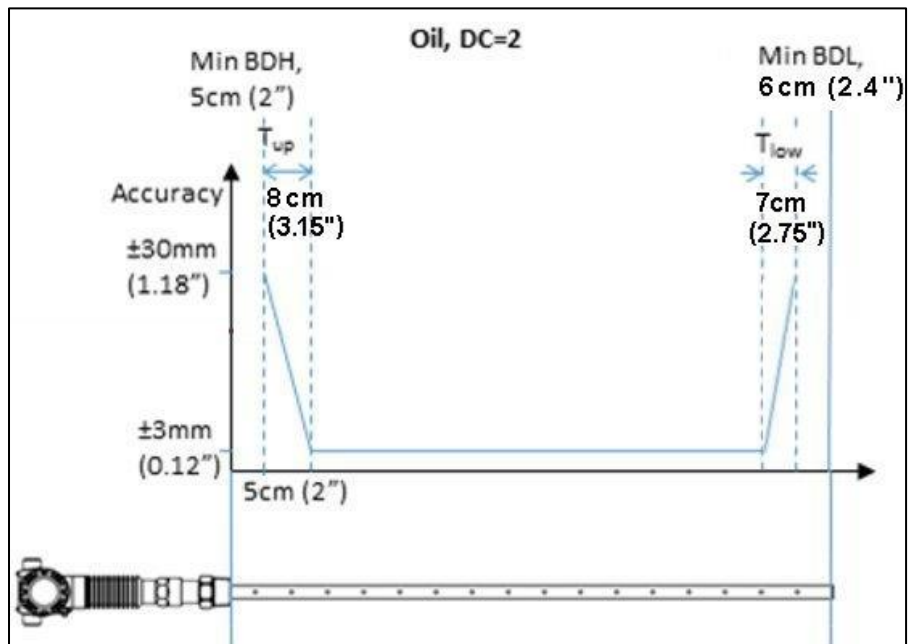

Figure 2-6: Upper transition zone length and minimum blocking distance high (BDH) and minimum blocking distance low (BDL) for coax probes in oil.

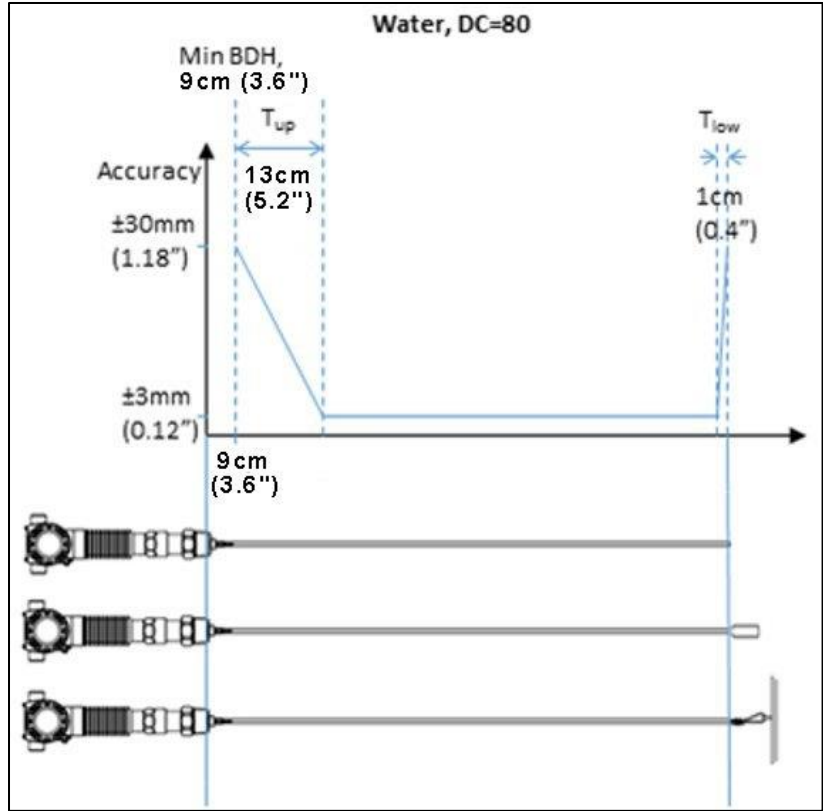

Figure 2-7: Transition zone lengths and minimum blocking distance high (BDH) for single lead probes in water.

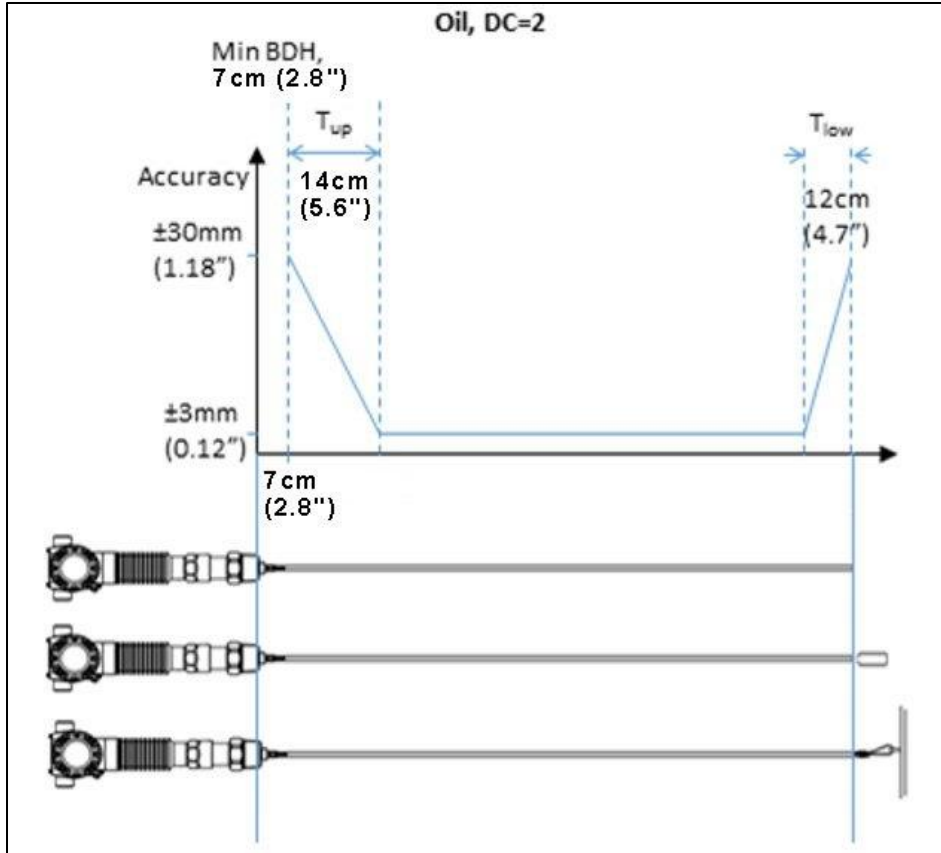

Figure 2-8: Transition zone lengths and minimum blocking distance high (BDH) for single lead (i.e. rod and rope) probes in oil.

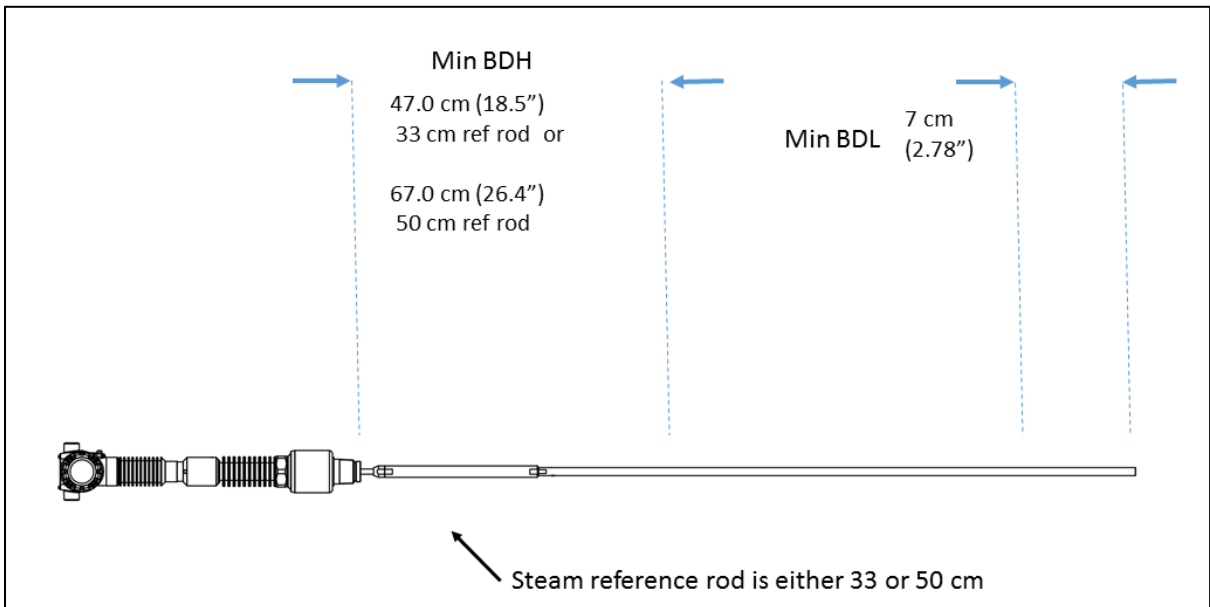

Figure 2-9 Minimum blocking distances, steam application for a threaded HTHP process connector

Note: BDH depends on threaded or flanged. Rods are either 30 or 50 cm. See [Error! Reference source not found.](#)

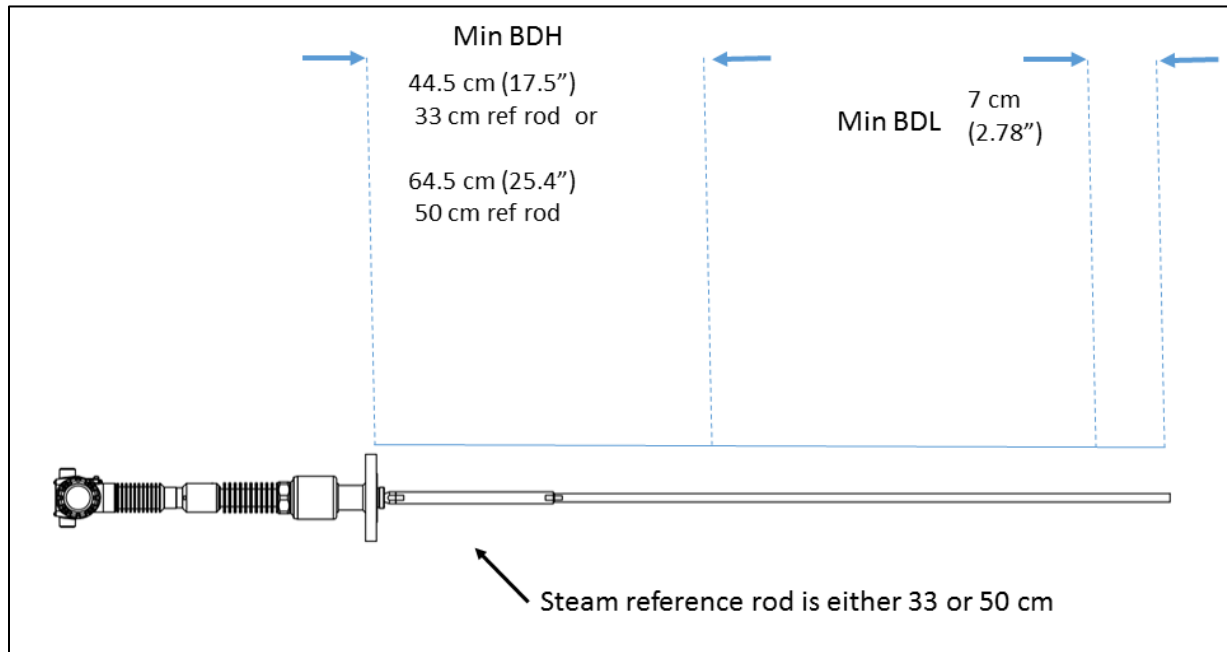

Figure 2-10 Minimum blocking distance, steam application for a flanged HTHP process connector

Table 2-1: Blocking Distance High

Process connector type	Saturated Steam Ref Length	Minimum BDH	Min dist to inlet or surface with DC corrected measurement
Threaded	30 cm	47.0 cm	58.0 cm
	50 cm	67.0 cm	78.0 cm
Flanged	30 cm	44.5 cm	55.5 cm
	50 cm	64.5 cm	75.5 cm

Minimum BDH and distance from reference plane to top inlet depends on transmitter configuration.

Note: these distances also apply to coax probes as we turn off the dynamic calculation when the surface is closer than this value.

Interface accuracy and range

When measuring interface the accuracy of both the surface and interface level is ± 3 mm and the minimum interface thickness that can be measured is 7 cm. However, restrictions exist for interface measurements depending on the application and on the dielectric constant (DC) of the measured products:

- Maximum dielectric constant of the upper medium: 9
- Minimum dielectric constant of the lower medium: 10
- Minimum difference in dielectric constant between the upper and lower medium: 8
- Minimum upper product thickness: 7cm

In addition, the maximum upper product thickness that can be measured will be restricted by the measured products. In the case of low absorption by the upper medium, upper product thicknesses of greater than 30 meters can be measured. In contrast, in strongly absorbing upper media, only upper product thicknesses of less than a couple of meters can be measured. In general, absorption will tend to be higher in media with higher dielectric constant. Therefore, the measurable thickness range of the upper product will be lower with higher upper product dielectric constant applications ($DC_U > 3$ or 4).

When the upper product thickness drops below 15cm approximately, the surface and interface reflections start to overlap. The transmitter will continue to measure the upper product thickness accurately down to 7 cm although the echo curve might only show one reflection for both surface and interface. If the transmitter fails to measure upper product thicknesses below 15 cm or if the measurement of thin interfaces is inaccurate, it might be necessary to adjust the reflection models using the Honeywell DTM. Refer to the *SLG 700 HART Option manual, #34-SL-25-06* for details on adjusting model parameters.

Note: The level transmitter is designed to measure properly only when the upper product thickness is greater or equal to 7 cm. For example, upon restart the transmitter will not attempt to provide a surface and interface measurement if the upper product thickness is less than 7 cm.

Note: If the surface level is never going to exceed the minimum blocking distance high (min BDH) for the transmitter configuration, it is recommended to keep full tank detection option off.

2.5 Process Applications

The SLG 700 Level transmitter is designed to work with a wide range of process conditions. The sensor offers a total of 5 application modes:

- Single Liquid
- Two Liquids, flooded (only interface between two liquids is measured)
- Two Liquids, non-flooded (surface and interface are both measured)
- Steam Applications (single water-steam interface is measured)
- Low-Dielectric Single Liquid Measurements (the end of the probe is measured and the surface level is estimated from that and the DC).

New in R200 are Steam applications (discussed in Section 2.5.4) and the Low DC Measurement. The latter is applicable when the dielectric of the medium is so low that barely any of the radar pulse is reflected, see 2.5.2. Also new for R200 is that the applications other than Single Liquid are licensed options, that is, a license key must be obtained from the factory and entered into the transmitter before that application will become operational.

2.5.1 Single Liquid

The most common application is Single Liquid where only a distance to the upper surface measurement is performed. It is possible that the dielectric of the air or gas above the liquid has a different dielectric constant from unity, but in most conditions, the vapor DC can be set to 1.

Measurements can be made in turbulent conditions or foaming conditions. However, in some situations special precautions must be taken (see Section 2.6).

2.5.2 Two Liquid Applications

The flooded and non-flooded applications are both available with the same license key. The flooded application is essentially a single surface measurement but in the case where a tank is always fully filled with two liquids and the position of the interface between them varies. The measured level is that of the interface.

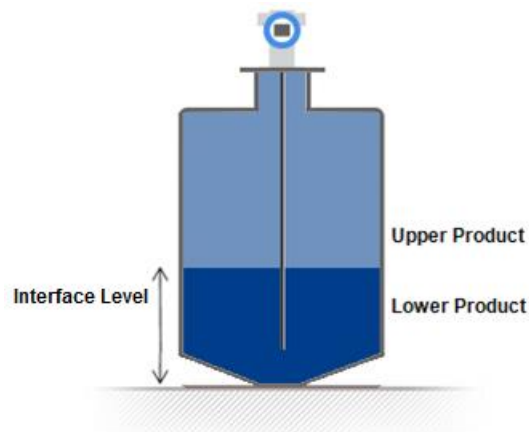

Figure 2-11: Two-liquids Flooded

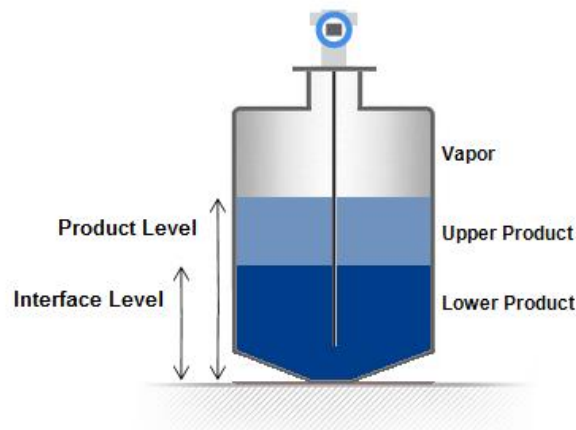

Figure 2-12: Two-liquids non-flooded.

Two-liquid non-flooded application type is used in cases such as water beneath a hydrocarbon in a separation tank. Both the top level and interface must be measured. The low-DC material is assumed to be on top of the higher DC material. As of R200 this application type is a pay-for-feature option; however, transmitters installed prior to R200 will automatically generate a license for this application if the device is upgraded.

In two-liquid applications the dielectric of the upper liquid is required to measure the true position of the interface between upper and lower fluid. Errors in this value result in error of the interface and its thickness.

It is recommended that the Max Filling rate be set as low as is acceptable (say 0.1 m/s) because it reduces the chance that the wrong echo is selected during the processing of the RADAR echo. Amplitude tracking should be turned on, especially if the attenuation of the upper fluid is not well known.

Note that if the primary variable is either interface position or thickness, the sensor stops reporting as soon as the surface has entered the set blocking zone. Surface measurements are not made in the blocking zone but are required to measure the true position of the interface. If the level moving into blocking zones is unavoidable, the sensor should be set to Non-Latching mode (HART transmitters), where once the primary variable is lost, a new full probe scan is triggered until the transmitter recovers.

When measuring interface the accuracy of both the surface and interface level is ± 3 mm or 0.03%, whichever is greater, and the minimum interface thickness that can be measured is 7 cm. However, restrictions exist for interface measurements depending on the application and on the dielectric constant (DC) of the measured products:

- Maximum dielectric constant of the upper medium: 9
- Minimum dielectric constant of the lower medium: 10
- Minimum difference in dielectric constant between the upper and lower medium: 8
- Minimum upper product thickness: 7cm

In addition, the maximum upper product thickness that can be measured will be restricted by the measured products. In the case of low absorption by the upper medium, upper product thicknesses of greater than 30 meters can be measured. In contrast, in strongly absorbing upper media, only upper product thicknesses of less than a couple of meters can be measured.

In general, absorption will tend to be higher in media with higher dielectric constant. Therefore, the measurable thickness range of the upper product will be lower with higher upper product dielectric constant applications (DCU >3 or 4).

When the upper product thickness drops below 15 cm approximately, the surface and interface reflections start to overlap. The transmitter will continue to measure the upper product thickness accurately down to 7 cm although the echo curve might only show one reflection for both surface and interface. If the transmitter fails to measure upper product thicknesses below 15cm or if the measurement of thin interfaces is inaccurate, it might be necessary to adjust the reflection models using the Honeywell DTM. Refer to the SLG 700 HART Option manual, #34-SL-25-06 for details on adjusting model parameters.

Note: The level transmitter is designed to measure properly only when the upper product thickness is greater or equal to 7 cm. For example, upon restart the transmitter will not attempt to provide a surface and interface measurement if the upper product thickness is less than 7 cm.

Note: If the surface level is never going to exceed the minimum blocking distance high (min BDH) for the transmitter configuration, it is recommended to keep full tank detection option off.

For two-liquid non-flooded applications, the transmitter can simultaneously calculate a number of related parameters related surface and interface positions.

2.5.3 Low Dielectric Applications

R200 introduced a new measurement technique that can be helpful when the surface reflection is either very small or otherwise unstable.

For any reasonably transparent medium, the sensor can detect the pulse reflected at the end of the probe. Since the level of fluid influences the propagation time for the radar pulse, the end of probe signal will appear to recede as the tank fills. This apparent shift of the end of probe signal is used to calculate the level of the surface.

However, this technique requires precise knowledge of both the probe length and the dielectric constant of the medium. It is not recommended for regular single liquid applications with dielectrics over approximately 2.5.

A procedure is available on the display or DTM to initiate an automatic probe length calibration. This can be helpful in setting up this measurement mode and should of course only be performed on an empty tank. Level measurement through the end-of-probe reflection algorithm is a pay-for-feature option.

In some cases, this mode can provide level measurements where the single liquid application fails when excessive turbulence, foam or emulsions block the reflection from the surface but still allow the end of probe to be detected by the transmitter. It should be noted that the measurement accuracy when using this application type can be greater than the nominal ± 3 mm possible with the other application types.

The end of the probe must be readily detectable for this method to work. In practice, this means that rod and coax probe types are preferred as they produce bigger end reflections. Wire probes with end weights are less preferred but still possible. Wire probes with other end terminations are not recommended unless it is known that the end reflection is usable. Additionally, surface reflections and material attenuation should be considered.

Usually, it will be the material absorption which determines the depth under which the end of probe will be visible. This can be difficult to predict as published tables might not be correct especially if there are material impurities or absorbed water present.

2.5.4 Steam Boiler Applications

Sensor revision R200 introduced a new application type: the measurement of the water level in high-pressure steam boilers.

Unlike regular measurement applications where the user can enter a value for the dielectric constant of the medium above the liquid, a measurement inside a boiler has a dynamic value of the dielectric constant which varies with the steam pressure and temperature. To measure the resulting varying speed of the radar pulse, the measurement rod is extended to include a reference reflector that sits above the measurement area.

After installation but before the vessel is pressurized, the observed length of the probe to this reference reflection is measured and recorded by the sensor. During subsequent measurements, the apparent change in this distance is calculated and used to correct the propagation speed of the radar pulse.

Steam applications always use the SLG726 (HTHP high temperature high pressure) process connector with or without the 3-m remote housing extension. In all cases, the sensor uses a reflection from the HTHP process connector as the reference plane from which all distances are calculated. In total, therefore, the sensor must have four calibrated reflection models: the internal reference from the sensor electronics, the process connector reflection mentioned above, the steam reference reflection and the water surface reflection. While default model values are supplied for all, it is highly recommended to use the DTM to display a typical echo and verify that the model amplitudes are set correctly. If possible, verify that the process connector model is still correct at the boiler operating temperature (amplitude tracking only tracks level reflection echoes).

A typical example of an echo observed is shown below:

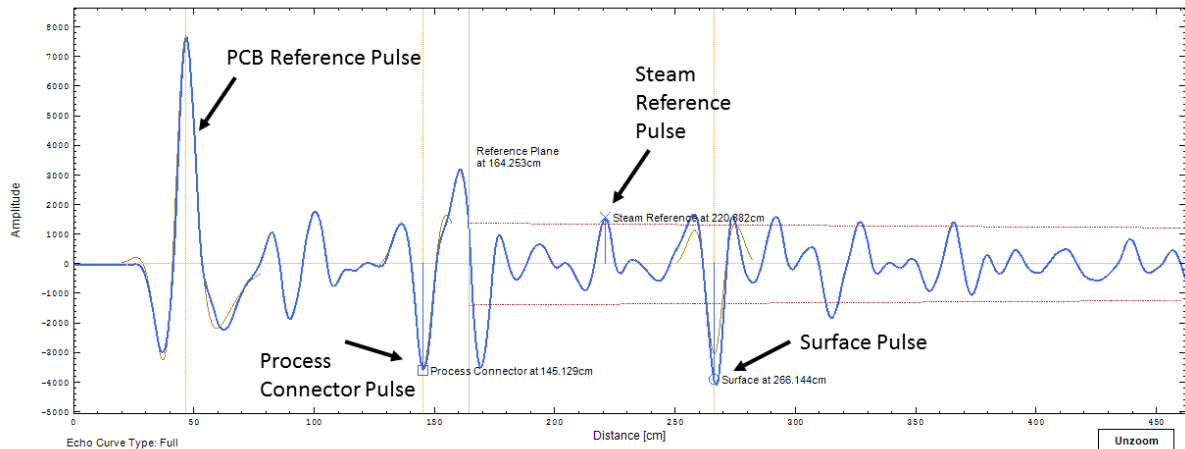

Figure 2-13 Typical Echo steam application echo with vapor reference rod

The transmitter probe type is restricted to coaxial or rod and the mounting location must be either tank, for coax only, or bypass. In the case of a bypass, the diameter must be specified correctly. Note the length of the steam reference rod should be calibrated after installation and before the vessel is pressurized. This can be done from the display module or the DTM or the DD. Background subtraction is not used for steam applications and it is advised that amplitude tracking be left on.

2.6 Process Condition Considerations

Process conditions can affect the way the surface appears to the GWR Transmitter.

2.6.1 Turbulence

Turbulence can result in the following measurement issues:

- The height of the surface reflection appears smaller.
- The level measurements display higher variability.

In extreme cases of turbulence, the surface level measurement can be lost entirely. To counteract these effects, it is a good idea to enable amplitude tracking, and to increase the maximum fill rate parameter. Alternatively, instead of a single liquid application type, if the dielectric constant is low enough, measurements can be made with the Low DC application type.

2.6.2 Foam or Emulsions

Foam on the surface of the material being measured can influence the measurement. While light foaming would have no influence at all, very heavy foam can degrade the measuring signal. Foam can result in:

- The height of the surface reflection appearing smaller or even disappearing.
- Loss of accuracy due to an badly-defined surface.

Also in this case, amplitude tracking (See Section 2.3.1). or a Low DC application (see section 2.5.3). selection can be attempted to counteract these problems.

2.6.3 FEP Probe

Revision R200 introduced FEP-coated probes for SLG720 transmitters (Standard Temperature and Pressure). FEP is very similar in composition to PTFE. It has most of the excellent physical, chemical, and electrical properties of PTFE, but with the ability to be processed using conventional thermoplastics processing techniques. With FEP-coated probes, the only wetted material is FEP. In addition to avoiding chemical compatibility issues between the process connector or probe with the chemical process being monitored, FEP-coated probes may avoid some potential build up issues, either because process chemicals are less likely to stick to FEP or because there are no voids in which chemicals can accumulate.

The application types available are single liquid, two liquid with interface measurement, and the low-DC algorithm type. Internally the sensor has algorithms to correct for the dispersion (change in pulse shape) of RADAR pulses along such probes. Typically these effects are only visible for probe lengths over about 10 m (33 ft.). It is important that the user correctly selects FEP-coated probes (either rod or wire) when setting up the sensor. FEP applications are a pay-for-feature option. Refer to the HART or FOUNDATION Fieldbus User's Manuals for further details of advanced configuration with these probes.

2.7 Container Considerations

2.7.1 Shapes

The SLG 700 transmitter may be used in any shape of container. In general, it is designed to be mounted vertically on top of the container, although angled mounting is also possible. See section 3.2.6 for angled mounting limitations.

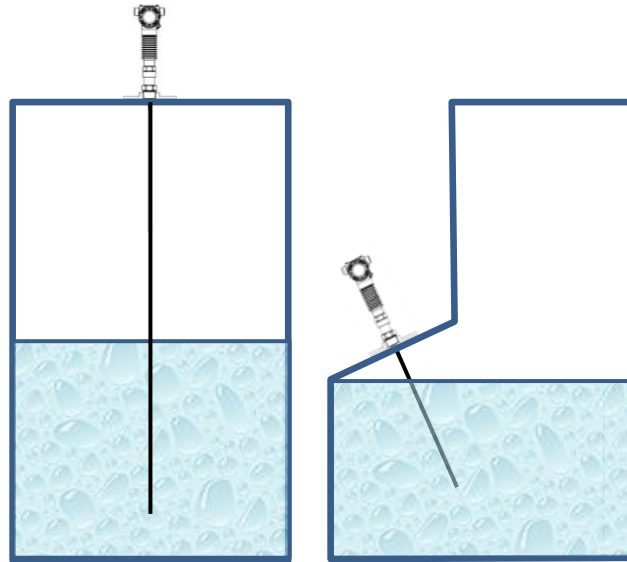

Figure 2-14: Top vertical and angled mounting

2.7.2 Materials (plastic vs. metal)

The transmitter may be successfully used in containers made of any materials. When planning the installation of the transmitter be aware that metal walls of the container reflect the measuring signal and in some circumstances, may help amplify the useful signal. Polymer walls of the container are transparent to the measuring signal. If the transmitter is installed close to a polymer wall, the measuring signal may reflect from metallic elements that are outside of the container. In addition, a transmitter installed very close to a polymer wall may experience greater signal attenuation which can reduce the measurement range of the instrument.

To mount a transmitter with threaded or small flange connection in a non-metallic container an additional signal reflector is required. Refer to section 3.2.10

When the transmitter is installed in a non-metallic container a coax probe is recommended if immunity to radiated electromagnetic fields (as per EN 61326 & IEC 61000-4-3) is required.

2.8 Blocking distance high and blocking distance low guidance

The minimum blocking distances and accuracy in the transition zones may be compromised in certain applications. In these cases and in order to meet the required specifications, it is necessary to follow the guidance provided below. If the sensor performances in the transition and blocking zones are compromised due to the presence of an obstruction and if the performances cannot be improved, it is advisable to increase the configured blocking distances accordingly. The latter will prevent the sensor from finding erroneous reflections in these regions.

2.8.1 Blocking distance high (BDH) guidance

Meeting the minimum blocking distance high specification may require recording a field background. A field background is captured when the tank is empty or when the tank level is below the minimum required distance (See Section 2.4.2). The field background records the reflected signal near the process connector. The background data is subsequently removed from the echo curve that is used for analysis.

The length of the field background depends on the type of sensor, the length of the probe and the length of the nozzle (if used). A field background may be automatically updated if the Dynamic Background option is turned on.

2.8.2 Blocking distance low (BDL) guidance

To meet the blocking distance low specifications, the following three conditions apply:

- The probe type must be configured properly. For example, it is necessary to indicate if a coax, a rod or a wire is used and what is the termination (end weight, centering disk, etc.).
- The probe length must be configured accurately. The probe length is set at factory time however if the probe has been cut or a centering disk was added it may be necessary to reconfigure the probe length. See section 0 for details on centering disks and configured probe length.
- In some cases, it might be necessary to adjust the end of probe model. For example, if the end of probe is close to the bottom of the tank or to an obstacle, the default end of probe model parameters might not be suitable. *Refer to the SLG 700 HART Option manual, #34-SL-25-06 or the SLG 700 FOUNDATION Fieldbus manual, #34-SL-25-07, for details on adjusting model parameters.*

2.8.3 Blocking Distance, Full Tank Detection and Latching modes

When levels are lost into blocking zones the gauge display will report the level status as uncertain, the level is reported as the blocking distance (rather than the actual level). A digital indication will also be produced to indicate that the transmitter is detecting that the level is in the blocking zone. Refer to the appropriate user's manual for details of interface specific behavior.

Echos are generally not processed when the level is inside these zones except when Full Tank Detection is turned on. When the level lowers outside of the upper blocking zone or raises above the lower blocking zone, a small hysteresis distance is applied (2 cm and 3 cm for the upper and lower zones respectively) so that the sensor output remains consistent as the level hovers near the blocking distance and does not toggle back and forth between output states.

It is possible for the level to rapidly leave a blocking zone and exceed the maximum fill rate. Note that the 'maximum fill rate' is the user-set maximum rate at which the level can change which will be reported before a digital flag will be set. As discussed in 2.3.3, when the maximum fill rate is exceeded, the transmitter considers the level lost and the gauge initiates the echo lost timeout counter and sets the digital 'rate of change exceeded' flag. Software R200 differs from previous versions as to the subsequent sensor behavior. In R200 and higher, depending on the latching mode settings, the gauge will eventually initiate a new full probe scan and likely recover the level. Prior to R200, the sensor would remain in the blocking zone until reset.

The maximum value for maximum fill rate is 0.9 m/s. 0.9 m is also close to the maximum amount that the transmitter can detect a level change between two readings. If this value is exceeded the 'rate of change' flag will not be set.

If the maximum filling rate is exceeded, the transmitter will continue to search for it in a narrow region for it until the echo-lost timeout is expired. The transmitter will then enter a measurement fault condition and search for the level over the entire probe length.

Note that if the rate of change is greater than a value greater than 0.9 m/s, the transmitter will likely not track the level and only a level lost fault condition is set, without the ROC alarm. may not be able to set a rate of change alarm. If the measurement is outside the blocking zones the transmitter will display a measurement fault until the echo lost timeout period has been exceeded, and then it will search for the level again. If it starts in a blocking distance position, it will stay in the blocking distance until the level reappears within the distance allowed by the ROC limit 0.9 m of the blocking zone. However, as of R200, if the level appears suddenly outside of blocking distance, failing ROC a level lost fault condition is set and output is maintained at the value of the blocking zone. This change has important consequences if latching mode is not set.

3 Transmitter Installation

3.1 Preparation

3.1.1 Installation sequence

Table 3-1 lists the overall installation steps. Details are provided in the indicated sections.

Table 3-1: Installation sequence

Step	Action	See Section
1	Perform mechanical installation of transmitter and probe.	3.2
2	Connect transmitter wiring and power.	3.3

After Installation check the transmitter's configuration and tune if necessary. Transmitters that were ordered using Honeywell's SmartLine Application and Validation Tool (AVT) will come with parameters pre-loaded so that the transmitter will give accurate level measurements out-of-the-box. Refer to *SLG 700 HART Option Manual, #34-SL-25-06* or the *SLG 700 FOUNDATION Fieldbus manual, #34-SL-25-07*.

3.1.2 Tools

Required tools depend on options ordered.

For this item (Model number signifiers)	Use this tool
M3 set screw for Coaxial coupler (SCA ACA)	AF ¹ 1.5 mm Allen key
M4 set screw for Electronics Housing rotation	AF 2.0 mm Allen key
M5 set screw for Wire probe end weight (SWA, SWB)	AF 2.5 mm Allen key
Rod probe (8mm) (SRA, SRH, SRJ, SCA)	AF 7 mm wrench
Rod probe and nut (12 mm) (SRB, SRM, SRN)	AF 10 mm wrench
Rod probe (16mm) (SRK, SRL, SCB)	AF 14 mm wrench
Saturated steam reference rod (22 mm)	AF 20 mm wrench
Probe nut (8mm) (SRA, SRH, SRJ, SCA)	AF 8 mm wrench
Probe nut (16mm) (SRK, SRL, SCB)	AF 14 mm wrench
Saturated steam nut (22 mm)	AF 20 mm wrench
Centering disk bolt (Wire probe)	AF 17 mm wrench
Mounting thread ¾" and 1" (SLG720) (xx7A, xx1A)	AF 40 mm wrench
Mounting thread 1-½" (SLG720) (xx5A)	AF 50 mm wrench
Mounting thread 2" (SLG720) (Nx2A)	AF 60 mm wrench
Mounting thread 1-½", 2" (SLG726) (NS5A)	AF 60 mm wrench
Coaxial probe outer process connector (SCA SCB)	Process compatible thread locking compound is recommended (for example, Loctite 242)
Coaxial probe outer process connector (SCA, ACA)	Retaining ring pliers for internal diameter 20 mm
Coaxial probe outer process connector (SLG726 / SCB)	Retaining ring pliers for internal diameter 40 mm
Rod and coaxial probe cut to length	Metal saw
Wire probe cut to length	Saw or bolt cutter
Drill hole in coaxial outer tube (SLG720)	Drill and 6.0 mm drill bit
Remote mounting transmitter to bracket	Phillips screwdriver

¹ AF means across face referring to tool size.

3.2 Mechanical Installation

Follow the steps in [Table 3-2](#). See Section [3.3.1](#) for wiring and configuration steps.

Table 3-2: Mechanical installation sequence

Step	Action	See Section
1	Check probe dimensions and strength.	3.2.1
2	Trim probe to correct length.	3.2.3
3	Attach/assemble the probe to the process connector.	3.2.4
4	Attach centering disk to probe if applicable.	0
5	Mount the transmitter.	3.2.6 & 3.2.7
6	Rotate electronic housing to desired view angle (on models with optional display).	3.2.11
7	Secure the probe.	3.2.12
8	Install conduit entry plugs and adapters.	3.2.13

3.2.1 Check for correct probe dimensions and strength

Measure for correct probe length and check that your probe is within tensile or bending load limits. See section [3.2.2.1](#) for details.

See Table 3-14: Probe length for different probe types

3.2.2 Accuracy and measuring range specifications

See section [2.4.3](#)

Table 3-3: Sensor Details – All Models

Parameter	Description		
Probe	Type	Min / Max Length	Materials
	Rod	0.4m (1.3ft) / 6.3m (20.7ft)	SS 3161L, C-276*
	Wire	1.0m (3.3ft) / 50m (164 ft)	SS 316
	Coax	0.4m (1.3ft) / 6.3m (20.7ft)	SS 3161L, C-276*

*Only for model SLG720

Table 3-4: Minimum blocking distances and transition zones for the various probe types.

Probe Type	Media in Tank	Minimum Blocking Distance High [cm]	Upper Transition Zone, T _{up} [cm]	Minimum Blocking Distance Low [cm]	Lower Transition Zone, T _{low} [cm]
Rod/Wire	Water (DC=80)	9	13	0	1
Rod/Wire	Oil (DC=2)	7	14	0	12
Coax	Water (DC=80)	5	14	2	0
Coax	Oil (DC=2)	5	8	6	7

Table 3-5: Minimum blocking distances and Minimum distance to inlet or surface with DC corrected level for the Saturated Steam Application.

Process connector type	Saturated Steam Ref Length	Minimum BDH	Min dist to inlet or surface with DC corrected measurement	Minimum BDL
Threaded	30 cm	47.0 cm	58.0 cm	7 cm
	50 cm	67.0 cm	78.0 cm	
Flanged	30 cm	44.5 cm	55.5 cm	
	50 cm	64.5 cm	75.5 cm	

Table 3-6: Maximum measurement range for each probe type versus dielectric constant.

Probe	Wire		Rod		Coax	
	Min DC	Range	Min DC	Range	Min DC	Range
	1.4	15m (49ft)	1.4	6.3m (21ft)	1.4	6.3m (21ft)
	1.8	25m (82ft)				
	3	42m (138ft)				
	4	46m (151ft)				
	6	50m (164ft)				

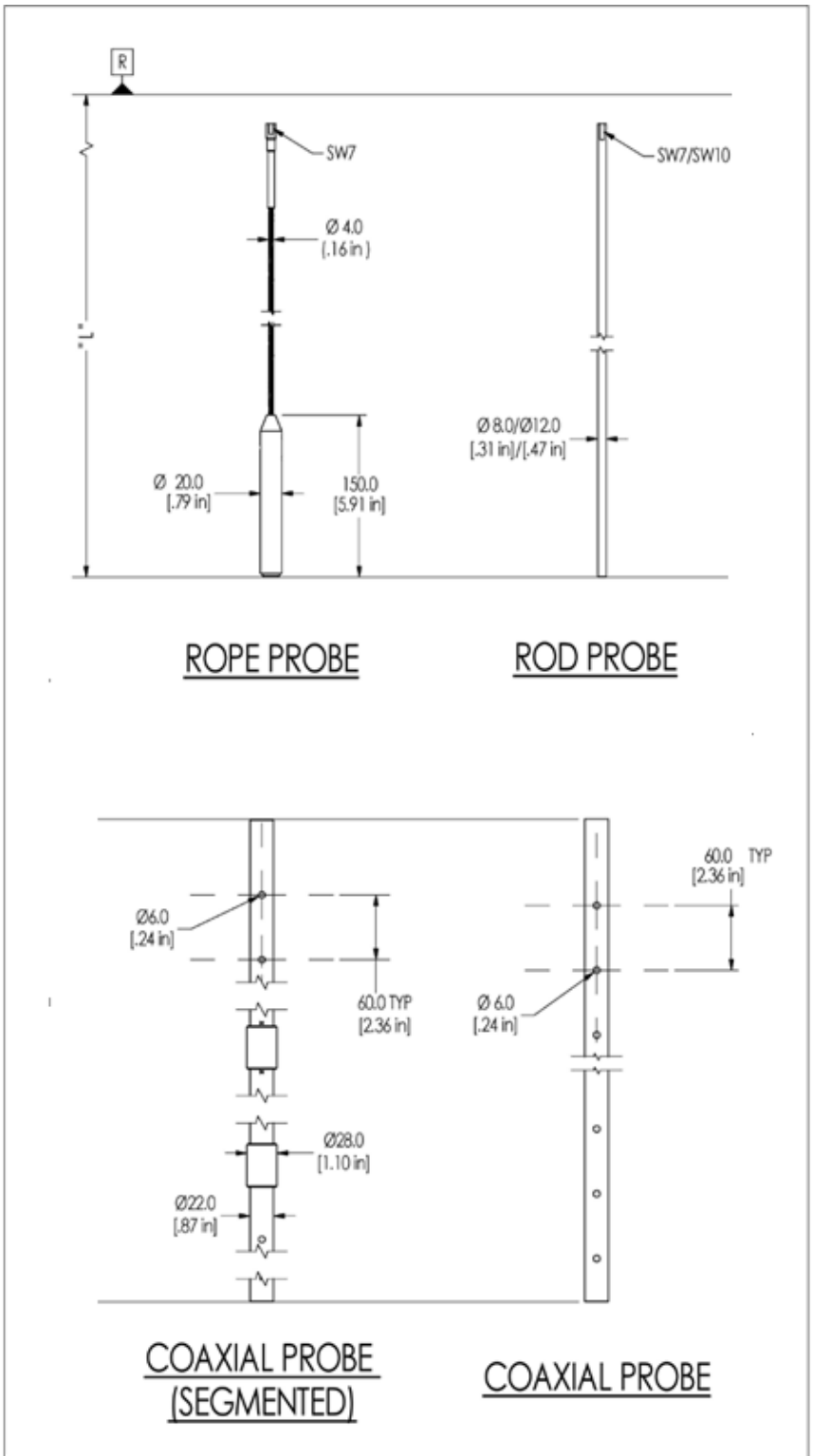

Figure 3-1 SLG720 probe dimensions, mm [in]

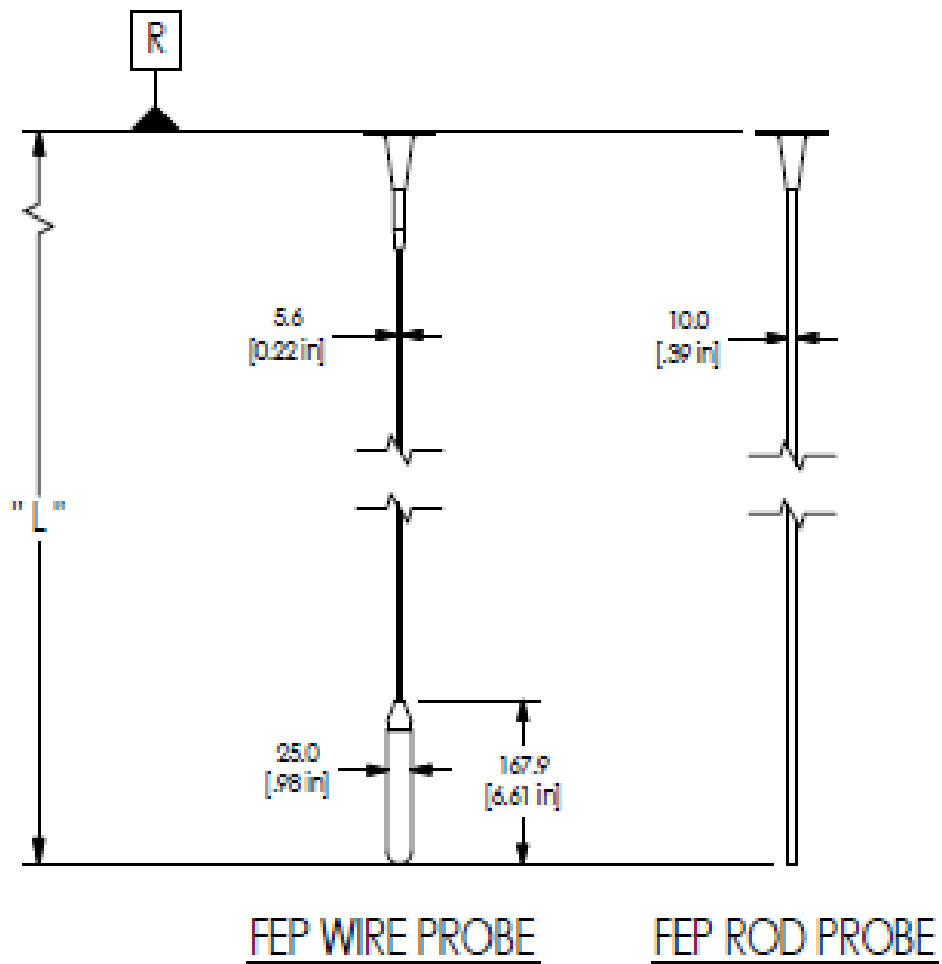
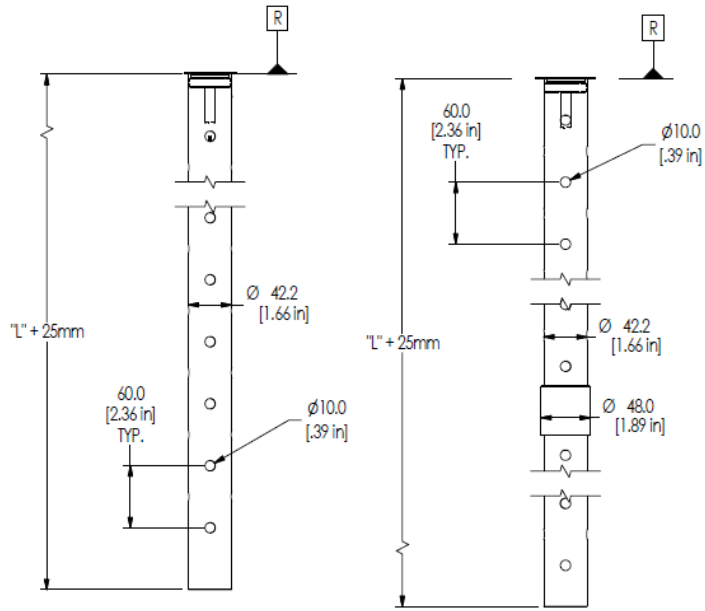
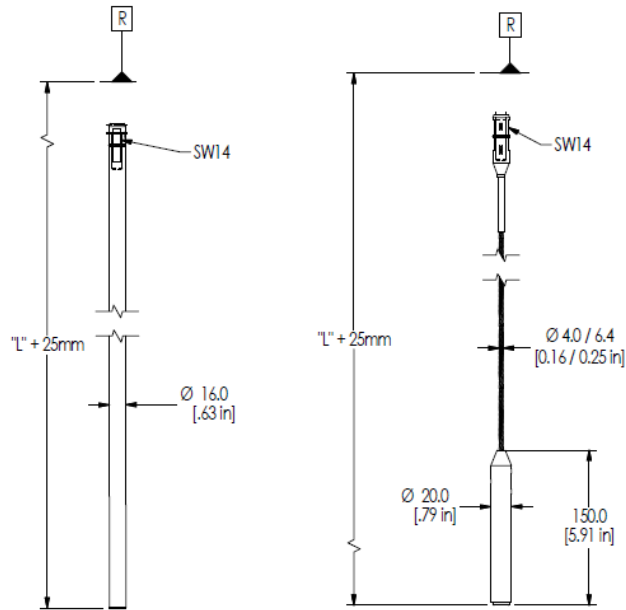

Figure 3-2: SLG720 FEP probe dimensions, mm [in]



COAXIAL PROBE
(CONTINUOUS)

COAXIAL PROBE
(SEGMENTED)



ROD PROBE

ROPE PROBE

Figure 3-3: SLG726 Threaded process connection probe dimensions; mm [in]

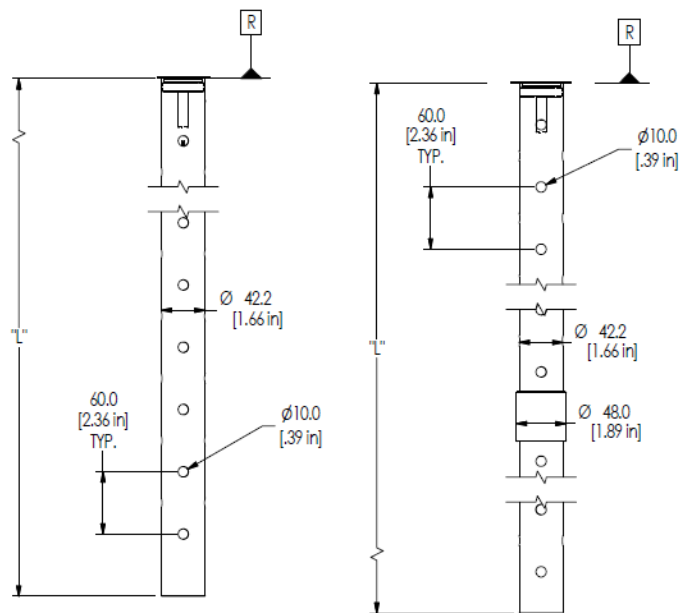

COAXIAL PROBE
(CONTINUOUS)

COAXIAL PROBE
(SEGMENTED)

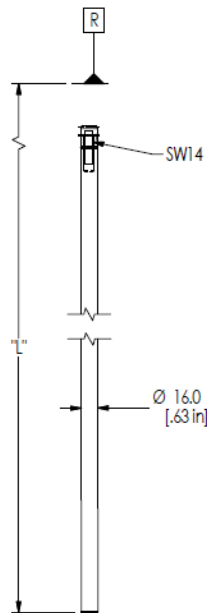

ROD PROBE

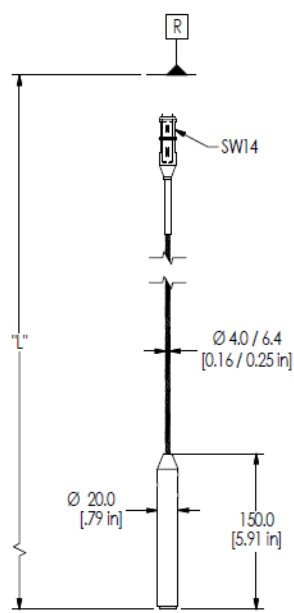

ROPE PROBE

Figure 3-4 SLG726 Flanged process connection probe dimensions; mm [in]

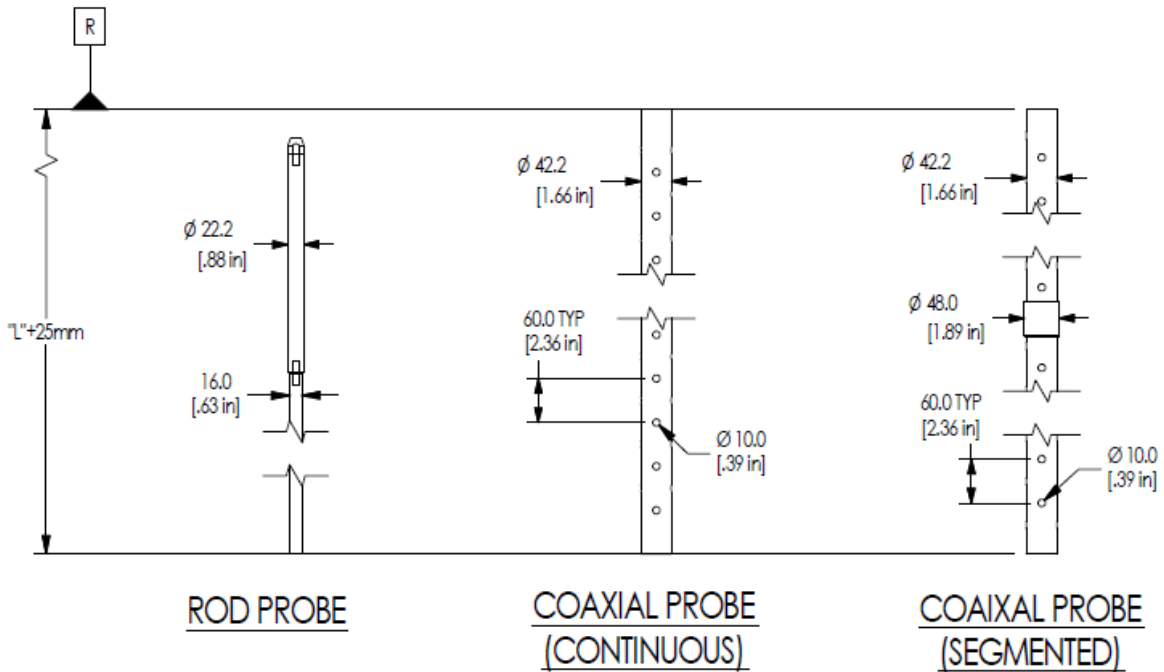

Figure 3-5: SLG726 Saturated steam application threaded process connection probe dimensions; mm [in]

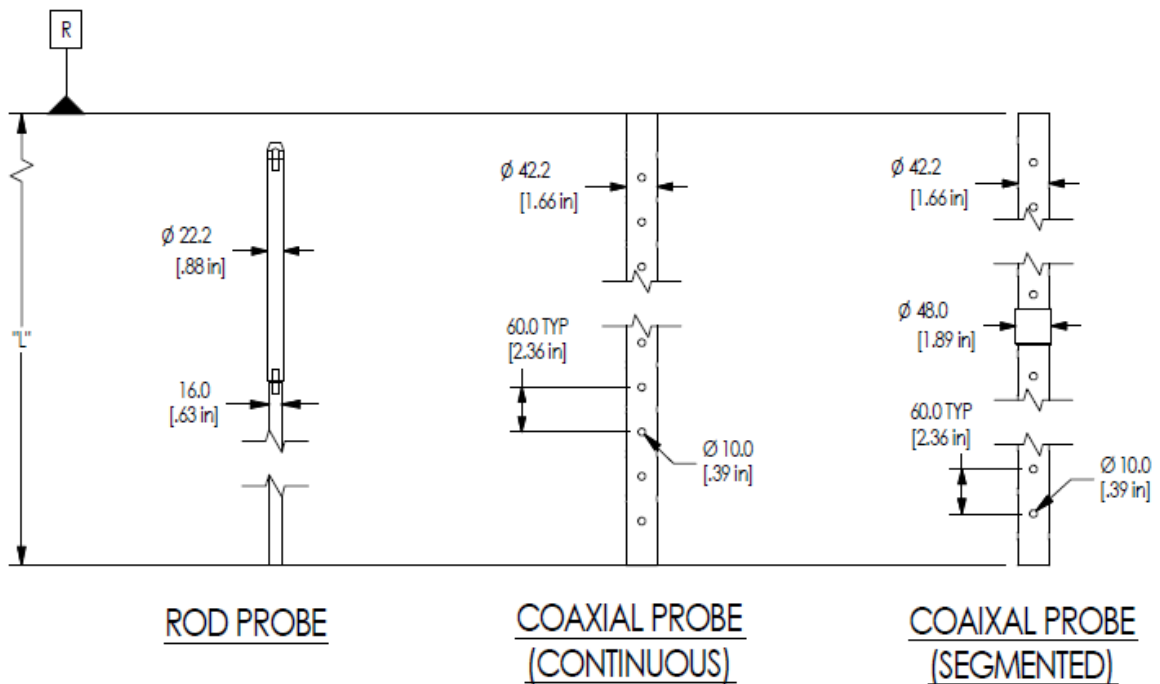

Figure 3-6: SLG726 Saturated steam application flanged process connection probe dimensions; mm [in]

3.2.2.1 Tensile load

Motion of the medium inside of the tank will impart load onto the probe of the transmitter. Flexible wire probes will experience tensile loading that will be transferred to the roof of the tank. Ensure that the maximum probe tensile load does not exceed maximum tank roof load. Depending on position, forces on anchored flexible probes can be two to ten times greater than that of flexible probes with end weights.

Table 3-7: Tensile load limits for flexible probe

Model	Probe Selection	Probe description	Tensile Load Limit [kN]	Maximum Roof Load [kN]
SLG720 SLG726	SWA, SWB, PWA, PWB	Wire, single, 4mm	5	15

3.2.2.2 Bending torque

A vertically mounted rigid probe bends due to fluid motion force. An angle mounted probe also bends from gravity. The mounting angle and total torque from these forces must not exceed the limits in [Table 3-8](#), [Table 3-9](#) and [Table 3-10](#). For excessive torque conditions consider using a flexible wire probe instead.

Table 3-8: Rigid (i.e. rod and coaxial) probe mounting angle limits

Total probe length	Maximum angle
1m (3')	30°
2m (6')	8°
4m (13')	2°
6m (19')	1°

Table 3-9: Rod probe bending torque limits (all lengths)

Model	Probe description	Maximum Bending Torque [Nm]*
SLG720	Rod 8mm or FEP-coated rod, 10 mm	4
SLG726	Rod 16mm	25

*For an angle mounted probe reduce these limits by 50% to allow for bending from gravity.

Table 3-10: Coaxial probe bending load limits (all lengths)

Model	Probe Selection	Probe description	Maximum Bending Torque [Nm]*
SLG720	SCA	Coax 22mm, 2m (6') segments	50
SLG726	SCB	Coax 42mm, 2m (6') segments	100

*For an angle mounted probe reduce these limits by 50% to allow for bending from gravity.

To calculate your probe's torque due to fluid motion use the following formula and check it against the torque limits in [Table 3-9](#) and [Table 3-10](#).

$$M = c_d \times \frac{\rho}{2} \times v^2 \times d \times L_f \left(L - \frac{L_f}{2} \right)$$

Where:

M = Moment or torque

c_d = Friction factor

ρ [kg/m³] = Density of medium

v [m/s] = Velocity of medium perpendicular to probe

d [m] = Diameter of probe

L_f [m] = Level of medium

L [m] = Probe length

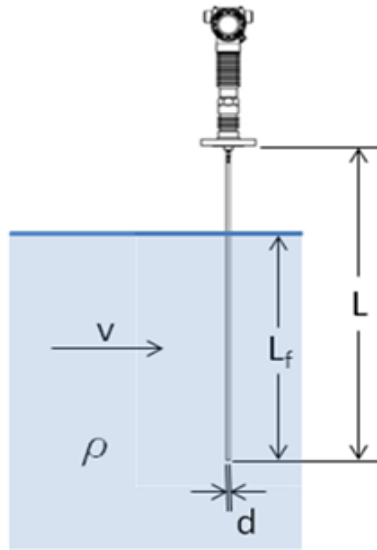

Example torque calculation for 8mm rod probe:

Friction factor (c_d) 0.9 (turbulent flow – High Reynolds number)

Density (ρ) 1000 kg/m³ (water)

Probe diameter (d) 0.008 m

$L_f = L$ (worst case)

These values yield the torque curves in Figure 3-7: Example bending torque values. For example, if the 8mm rod probe is a total length of 4m (two 2m segments) then by checking [Table 3-9](#) you find probes with 2m segments have a torque limit of 4.0Nm limit, which will be exceeded if fluid velocity is 0.4m/s, therefore you would need to use a coaxial or wire probe instead. If the same 8mm rod probe is angle mounted then the limit is half of 4.0Nm, or 2.0Nm, therefore fluid velocity of 0.3m/s exceeds this limit.

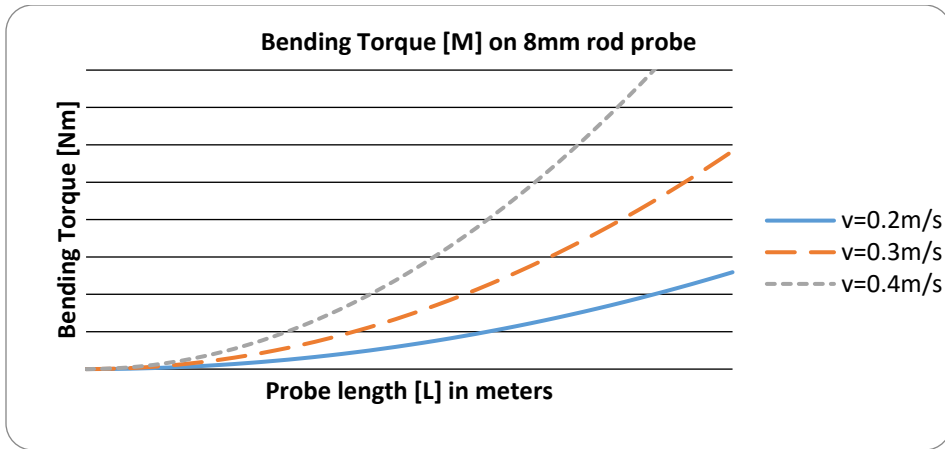

Figure 3-7: Example bending torque values

3.2.3 Trim the probe length



CAUTION: The minimum Blocking Distance Low (BDL) and accuracy in the low transition zone will be compromised if the BDL guidance is not followed. See Section 2.4.3

3.2.3.1 Shortening a rod probe

Where clearance to the bottom of the tank is less than 0.4” (10mm), the rod must be shortened.

Rod probes are supplied in segments. Cut on the terminating rod segment (the one with the unthreaded end).

3.2.3.2 Shortening a wire probe

Wire probes are provided with an end weight that is not attached.

Step	Action
1	Loosen the set screws holding the end weight to the rope.
2	Remove the end weight from the rope.
3	Measure the required wire length and wrap some adhesive tape around the wire at the cut location to help hold the wire strands together when cutting.
4	Use a hacksaw and make the cut.
5	Insert the wire back into the end weight and tighten the 3 set screws.

3.2.3.3 Shortening a SLG720 coaxial probe

Note: The coaxial probe trimming instruction applicable only to SLG720. For SLG726, if a coaxial probe is not the specified length, contact Honeywell’s Technical Assistance Center as a new probe could be required / ordered.

Technical Assistance Center (TAC): 800-822-7673 in North America or 1-602-313-5558 from the rest of the world.

Step	Action
1	Coaxial probe consists of inner rod and coaxial outer tube. To trim the coaxial probe, both inner rod and coaxial outer tube need to be trimmed. For trimming the inner rod, refer to rod probe trimming instruction detailed above. Avoid trimming the internal thread region of the inner rod.
2	To trim the coaxial outer tube, start on the terminating segment (the one with the unthreaded end). Mark and trim the outer tube to the same amount as the inner rod. Avoid trimming the coupler region of the outer tube.
3	Drill a 6mm hole through the end of the outer tube at location shown in Figure 3-8: Drill 6-mm diameter hole at the position shown on the coaxial outer conductor..

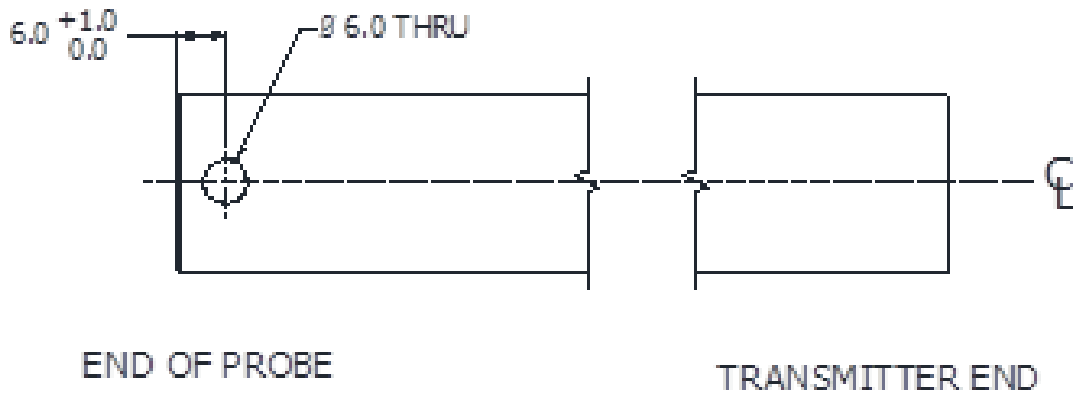



Figure 3-8: Drill 6-mm diameter hole at the position shown on the coaxial outer conductor.

3.2.4 Attach/assemble the probe

	<p>CAUTION: To reduce the risk of damage from electrostatic discharge, ensure the Electronic Housing is grounded before lowering a probe into a tank.</p>
---	--

3.2.4.1 Rod probe assembly

Rod probes are shipped in segments. The segments are attached to each other with a stud and a lock washer.

Step	Action
1	Fully thread the nut onto the central conductor. Using a lock washer, thread the first rod segment on to the central conductor. Torque the nut against rod probe and lock washer to secure the connection.
2	Thread the stud into first rod segment end. Using a lock washer thread the next segment onto the stud. Apply torque to secure the connection.
Note: Tighten each rod connection point to the following torques: <ul style="list-style-type: none">• SLG720 6.0Nm (4.4ft-lbs)• SLG726 15Nm (11ft-lbs)	
Note: For flanged SLG726 models, ensure the nut does not intrude into the process connector. See Error! Reference source not found. for more information.	

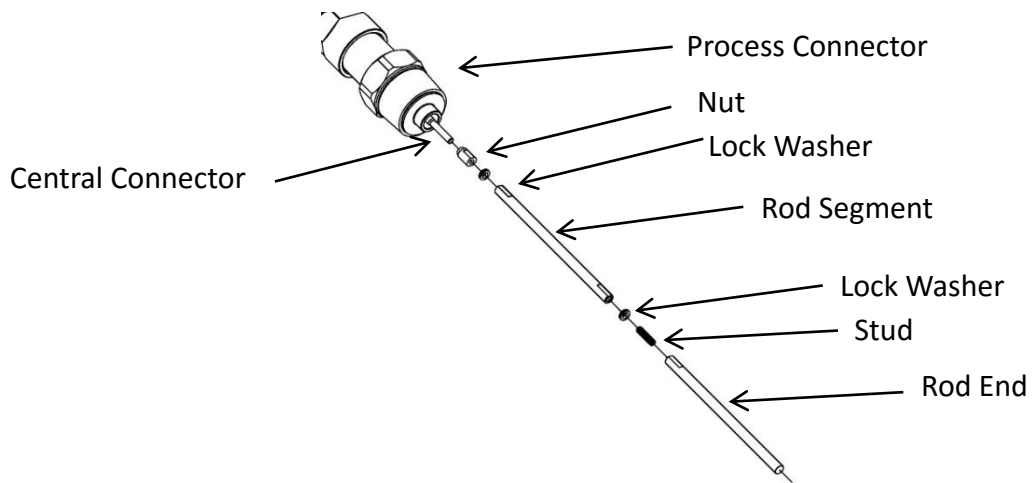

Figure 3-9: Rod probe assembly

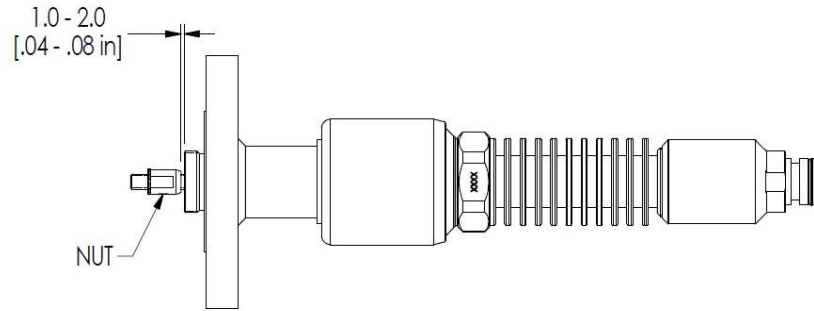

Figure 3-10: SLG726 flanged process connection, probe nut installation position, mm [in]

3.2.4.2 Wire probe assembly

Wire probes can be supplied with an optional end weight.

Step	Action
1	<p>Fully thread the nut onto the central conductor. Using a lock washer, thread the wire swage on to the central conductor. Torque the nut against probe and lock washer to secure the connection.</p> <p>Note: Tighten the wire stud and nut to the following torque:</p> <ul style="list-style-type: none"> • SLG720 6.0Nm (4.4ft-lbs) • SLG726 15Nm (11ft-lbs)
2	<p>If applicable, insert wire probe into end weight. Tighten the 3 set screws to secure end weight to wire probe</p> <p>Note: Torque set screws to 6Nm (4.4ft-lbs)</p>
<p>Note: For flanged SLG726 models, ensure the nut does not intrude into the bore of the process connector. See Figure 3-10: SLG726 flanged process connection, probe nut installation position, mm [in] for more information.</p>	

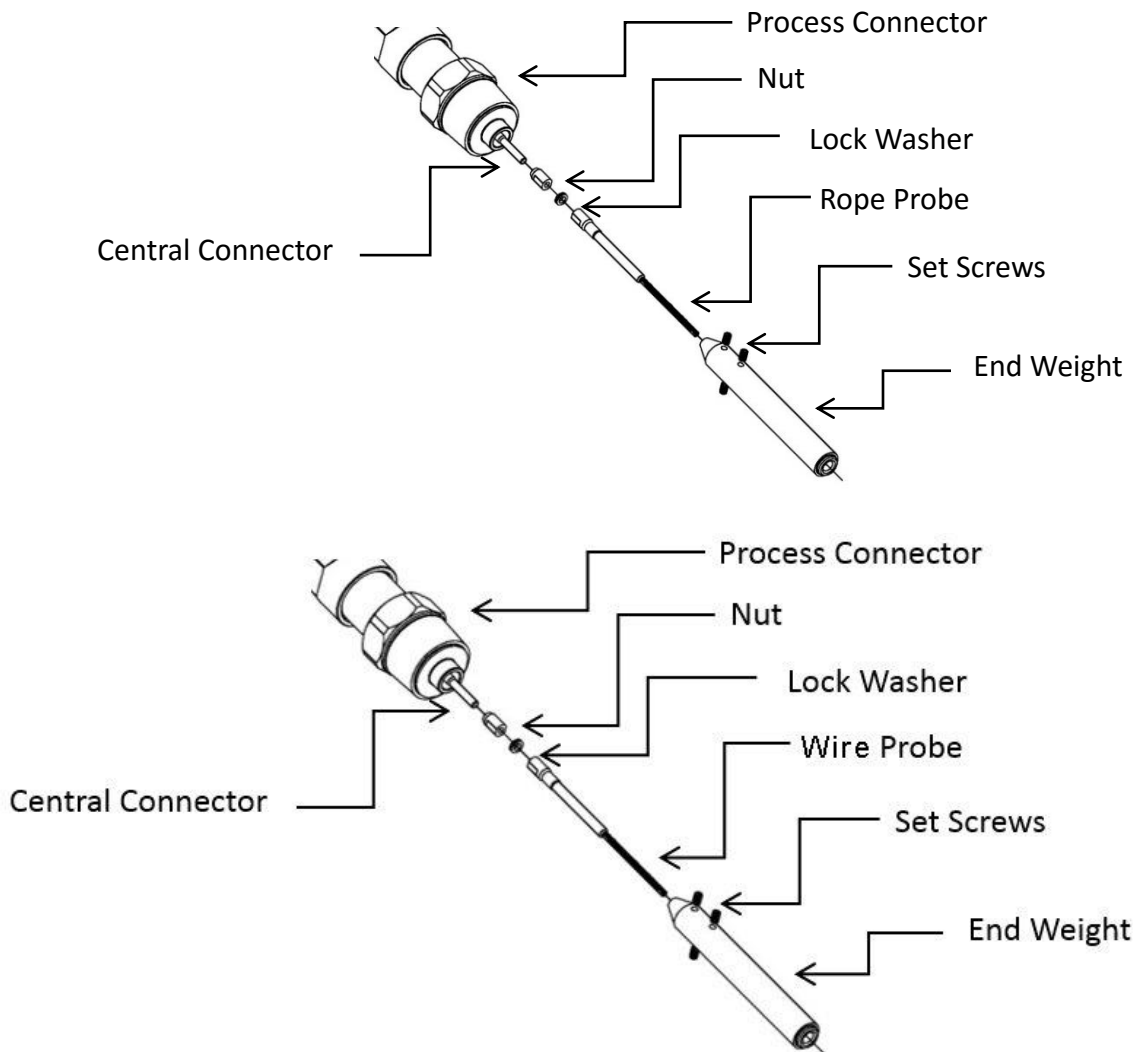

Figure 3-11: Wire probe assembly

3.2.4.3 Coaxial probe assembly

The coaxial probe consists of an inner rod conductor, surrounded by an outer tube shield. The concentricity of the inner rod inside of the outer tube is maintained by spacers placed along the probe length. Depending on the final length of the probe, the construction method may differ.

Note:	For the flanged HTHP, when constructing the probe, the nut should not intrude into the body of the process connector.
--------------	---

SLG720

The inner rod is comprised of 1.0m rod segments and one rod end. Depending on the length of the probe there may be 0 to 6 1.0m rod segments. As with the rod probe, the rod segments are attached to each other by way of a stud and lock washer, see Figure 3-13: SLG720 Coaxial probe assembly (single outer tube depicted). In the coaxial probe construction, a spacer is placed at each joint, retained by the lock washer.

If the coaxial probe is 2.0 m or shorter it will come with a single outer tube. If the probe length is longer than 2.0 m, the outer tube will be supplied in segments. There are three types of outer tube segments:

- Starter segment: which has an internal thread to attach to the process connector.
- Extension segment: which has external threads on both ends.
- End segment: which has an external thread on one end.

Probes over 2.0 m in length will always have one “starter” and one “end” segment, along with 0 to 2 extension segments in between. The tubes are connected to each other by way of a threaded tube coupler. It is recommended to build the coaxial probe 2 m at a time. That is, attach two 1.0 m rod segments together and slip an outer tube over the rod. Repeat until the probe is fully assembled.

Refer to Figure 3-13: SLG720 Coaxial probe assembly (single outer tube depicted) for the SLG720.

Probe Length ≤ 1.0m:

Step	Action
1	Fully thread the nut onto the central conductor of the process connector. Place a lock washer between the locknut and the rod segment and torque the nut against the rod segment and lock washer to secure the connection. Note: Tighten rod connection point to the following torque: <ul style="list-style-type: none">• SLG720 6.0Nm (4.4ft-lbs).
2	Slip the coaxial outer tube over the rod and spacer and tighten to the process connector. Note: Tighten connection point to the following torque: <ul style="list-style-type: none">• SLG720 30Nm (22ft-lbs). It is recommended that a process compatible thread locking compound (i.e. Loctite 242) be used on the outer conductor threaded joints.
3	Insert an end spacer into the end of tube. Align the holes in the end spacer with the holes in the outer tube and insert the 2 locking pins. Refer to Detail B of Figure 3-13: SLG720 Coaxial probe assembly (single outer tube depicted).

Probe Length 1.0m to 2.0m

Step	Action
1	<p>Fully thread the nut onto the central conductor of the process connector. Place a lock washer between the locknut and the first rod segment and torque the nut against the rod segment and lock washer to secure the connection.</p> <p>Note: Tighten rod connection point to the following torque:</p> <ul style="list-style-type: none"> • SLG720 6.0Nm (4.4ft-lbs)
2	<p>Slide a spacer onto first rod. Connect the rod "end" segment to first rod using a stud and lock washer. Refer to Detail A of Figure 3-13: SLG720 Coaxial probe assembly (single outer tube depicted).</p> <p>Note: Tighten rod connection point to the following torque:</p> <ul style="list-style-type: none"> • SLG720 6.0Nm (4.4ft-lbs)
3	<p>Slip the coaxial outer tube over the rod and tighten to the process connector.</p> <p>Note: Tighten connection point to the following torque:</p> <ul style="list-style-type: none"> • SLG720 30Nm (22ft-lbs) <p>It is recommended that a process compatible thread locking compound (i.e. Loctite 242) be used on the outer conductor threaded joints.</p>
4	<p>Insert an end spacer into the end of tube. Align the holes in the end spacer with the holes in the outer tube and insert the 2 locking pins. Refer to Detail B of Figure 3-13: SLG720 Coaxial probe assembly (single outer tube depicted).</p>

Probe Length > 2.0m

Step	Action
1	<p>Fully thread the nut onto the central conductor of the process connector. Place a lock washer between the locknut and the first rod segment and torque the nut against the rod segment and lock washer to secure the connection.</p> <p>Note: Tighten rod connection point to the following torque:</p> <ul style="list-style-type: none"> • SLG720 6.0Nm (4.4ft-lbs)
2	<p>Connect the rod segment to first rod using a spacer, a stud and lock washer as shown in Detail A of Figure 3-13: SLG720 Coaxial probe assembly (single outer tube depicted).</p> <p>Note: Tighten rod connection point to the following torque:</p> <ul style="list-style-type: none"> • SLG720 6.0Nm (4.4ft-lbs)
3	<p>Slip the "starter" coaxial outer tube over the rod and spacers and secure to the process connector using the M20x1 thread.</p> <p>Note: Tighten connection point to the following torque:</p> <ul style="list-style-type: none"> • SLG720 30Nm (22ft-lbs) <p>It is recommended that a process compatible thread locking compound (i.e. Loctite 242) be used on the outer conductor threaded joints.</p>
4	<p>Insert an end spacer into the end of tube. Align the holes in the end spacer with the holes in the outer tube and insert the 2 locking pins. Refer to Detail B of Figure 3-13: SLG720 Coaxial probe assembly (single outer tube depicted).</p>

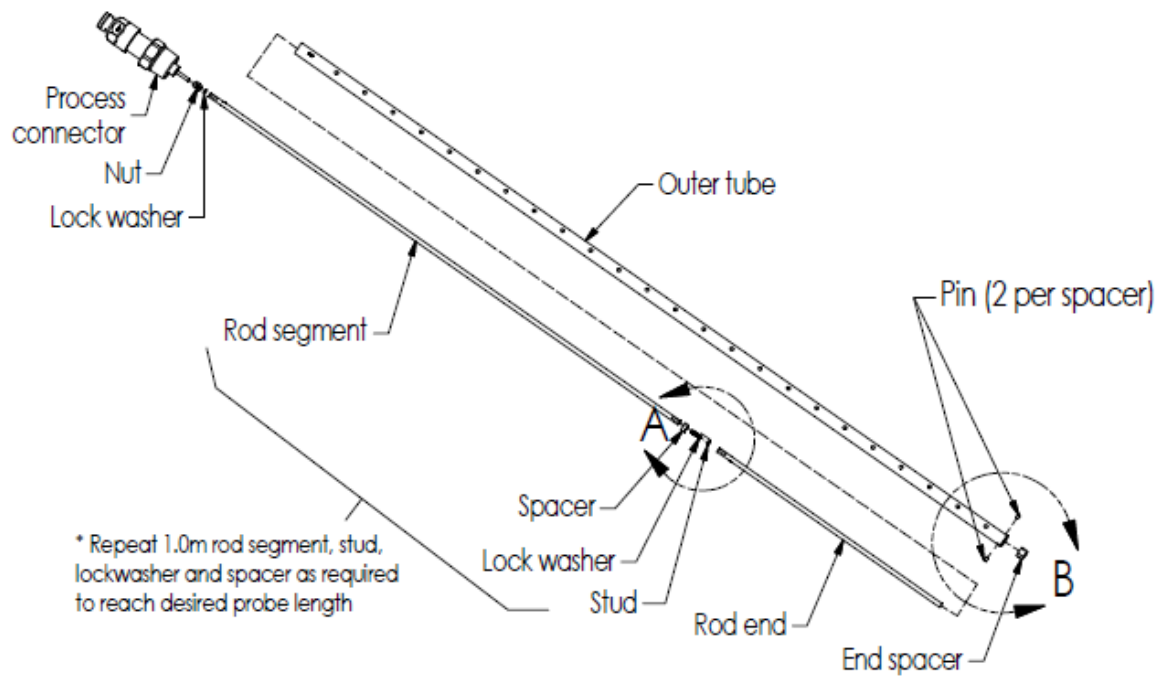

Figure 3-12: SLG720 Coaxial probe assembly (single outer tube depicted)

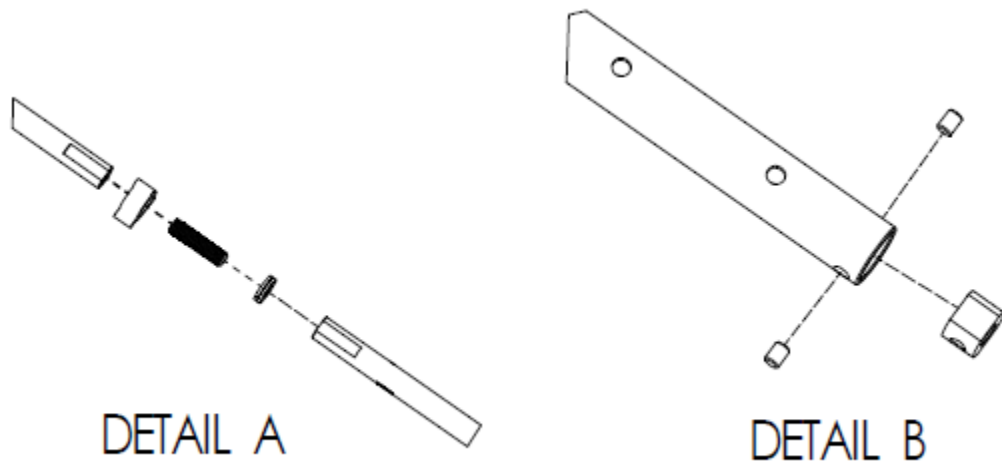

Figure 3-13: SLG720 Coaxial probe assembly (single outer tube depicted)

SLG726

The inner rod is comprised of 2.0m rod segments and one rod end. Depending on the length of the probe there may be 0 to 3 2.0m rod segments. As with the rod probe, the rod segments are attached to each other by way of a stud and lock washer. In the coaxial probe construction, a spacer is placed at each joint, retained by the lock washer. Because the spacers have closed sections, they must be slipped over the end prior to connecting the following rod segment. If the coaxial probe is 2.0m or shorter it will come with a single outer tube. If the probe length is longer than 2.0m, the outer tube will be supplied in segments. There are three types of outer tube segments:

- Starter segment: which has an internal thread to attach to the process connector,
- Extension segment: which had external threads on both ends,
- End segment: which has an external thread on one end.

Probes over 2.0m in length will always have one “starter” and one “end” segment, along with 0 to 2 extension segments in between. The tubes are connected to each other by way of a threaded tube coupler. It is recommended to build the coaxial probe 2m at a time. That is, attach one 2.0m rod segment and then place the tube over the rod. Slip a spacer onto one of the ends of the rod and attach the next rod segment. Repeat until the probe is together.

Tip: To ease assembly, construct the coaxial probe vertically, by suspending the transmitter by the process connector on a hoist or crane.

Refer to Figure 3-14: SLG726 Coaxial probe assembly for the SLG726.

Probe Length ≤ 2.0m

Step	Action
1	Thread the nut onto the central conductor of the process connector. Refer to Figure 3-10: SLG726 flanged process connection, probe nut installation position, mm [in] for nut position on flanged process connectors. Place a lock washer between the locknut and the first rod segment. Torque the nut against the rod segment and lock washer to secure the connection. Note: Tighten rod connection point to the following torque: <ul style="list-style-type: none"> • SLG726 15Nm (11ft-lbs)
2	Slip the coaxial outer tube over the rod and tighten to the process connector. Note: Tighten connection point to the following torque: <ul style="list-style-type: none"> • SLG726 30Nm (22ft-lbs) It is recommended that a process compatible thread locking compound (i.e. Loctite 242) be used on the outer conductor threaded joints.
3	Install end spacer between central conductor and outer tube in the counterbore. Secure end spacer using the retaining ring.

Probe Length > 2.0m

Step	Action
1	Thread the nut onto the central conductor of the process connector. Refer to Figure 3-10: SLG726 flanged process connection, probe nut installation position, mm [in] for nut position on flanged process connectors. Place a lock washer between the locknut and the first rod segment. Torque the nut against the rod segment and lock washer to secure the connection. Note: Tighten rod connection point to the following torque: <ul style="list-style-type: none"> • SLG726 15Nm (11ft-lbs)
2	Slip the "starter" coaxial outer tube over the rod and secure to the process connection using the M40x1 thread. Note: Tighten connection point to the following torque: <ul style="list-style-type: none"> • SLG726 30Nm (22ft-lbs) It is recommended that a process compatible thread locking compound (i.e. Loctite 242) be used on the outer conductor threaded joints.
3	Prior to securing the next rod segment, place a "star shaped" spacer over the rod segment end. The wrench flats on the rod end will index the spacer.
4	Depending on the probe length there could be 0 to 2 more rod segments and 1 rod "end" segment to assemble. Connect the subsequent rod segment to first, using a stud and lock washer. Note: Tighten rod connection point to the following torque: <ul style="list-style-type: none"> • SLG726 15Nm (11ft-lbs)
5	Slip a coaxial coupler over the last rod segment and spacer and tighten onto the previous outer tube segment. Note: Tighten connection point to the following torque: <ul style="list-style-type: none"> • SLG726 30Nm (22ft-lbs) It is recommended that a process compatible thread locking compound (i.e. Loctite 242) be used on the outer conductor threaded joints.

6	Depending on probe length there may be 0 to 2 coaxial outer tube "extension" segments and 1 coaxial tube "end" segment. Slip the next coaxial tube "extension" segment over the last rod segment and spacer and tighten to the coaxial coupler.
	Note: Tighten connection point to the following torque:
	• SLG726 30Nm (22ft-lbs)
	It is recommended that a process compatible thread locking compound (i.e. Loctite 242) be used on the outer conductor threaded joints.
7	Repeat steps 3-6 above until only the rod "end" segment and coax tube "end" segment remain.
8	Attach the last "star shaped" spacer over the previous rod segment end, as in step 3 above.
9	Attach rod "end" segment as in step 4 above.
10	Slip the coaxial coupler over the rod and spacer and tighten.
	Note: Tighten connection point to the following torque:
	• SLG726 30Nm (22ft-lbs)
	It is recommended that a process compatible thread locking compound (i.e. Loctite 242) be used on the outer conductor threaded joints.
11	Slip the coaxial end segment over the rod end segment and secure to coaxial coupler.
	Note: Tighten connection point to the following torque:
	• SLG726 30Nm (22ft-lbs)
	It is recommended that a process compatible thread locking compound (i.e. Loctite 242) be used on the outer conductor threaded joints.
12	Install the end spacer between central conductor and outer tube in counter-bore. Secure end spacer using the retaining ring.
13	Insert 2 M3 set screws into each coupler.
	Note: Tighten M3 set screws to 1.0Nm (8.8in-lb).
	It is recommended that a process compatible thread locking compound (i.e. Loctite 242) be used on each set screw.

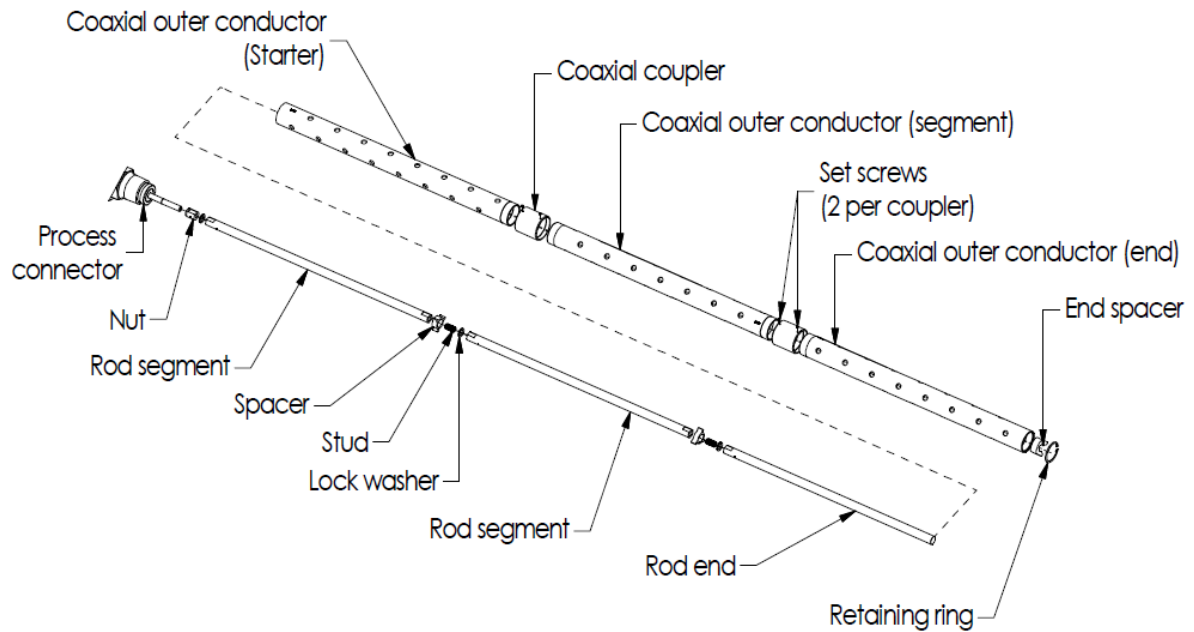

Figure 3-14: SLG726 Coaxial probe assembly

(Segmented outer tube depicted)

3.2.4.4 Saturated Steam Application Probe Assembly

Saturated steam application is available with SLG726 rod and coax probes. The nut and first inner rod segment have a larger diameter. The remaining hardware is identical. Refer to **Error! Reference source not found.** for saturated steam hardware. To assemble the probes, thread the saturated steam application nut to the central conductor, tapered end towards the process connector. For flanged process connectors, ensure the nut position is as shown in Figure 3-10: SLG726 flanged process connection, probe nut installation position, mm [in]. Place a lock washer between the locknut and the steam reference rod. Torque the connection to 15Nm (11ft-lbs). Proceed with the standard assembly procedures detailed above.

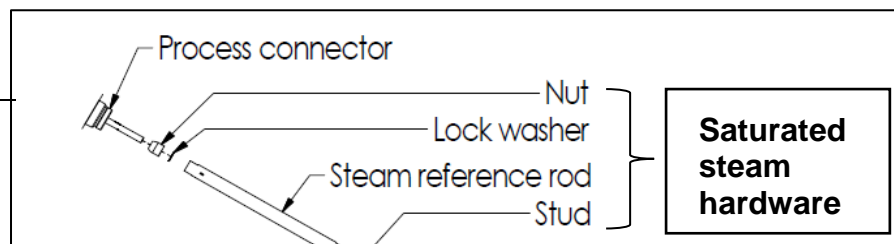

Figure 3-15 Saturated steam application rod probe assembly

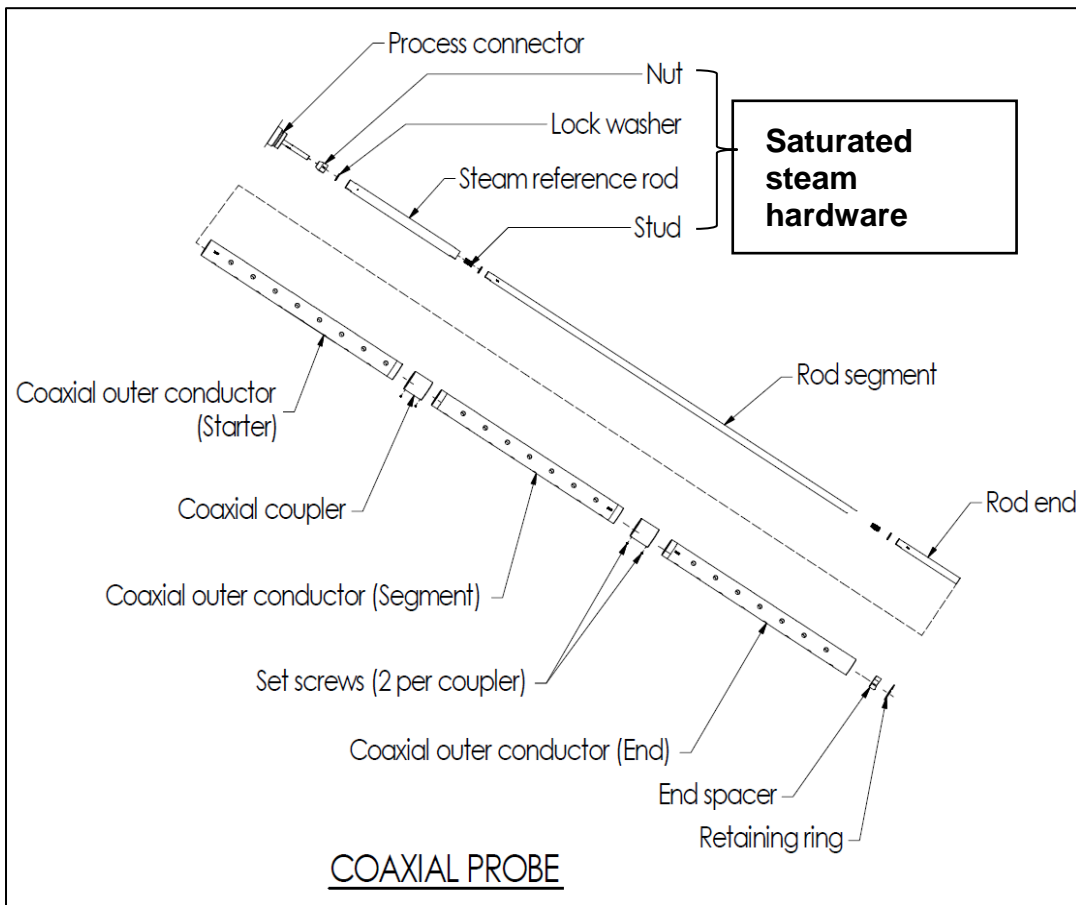

Figure 3-16: Saturated steam application coaxial probe assembly

3.2.4.5 No probe option

For those users who wish to supply their own rod or rope, the SLG 700 transmitter is available with a no probe option (SLGXXX-000).

Note:	Users should not attempt to supply their own coaxial probes.
--------------	--

When this option is selected the transmitter will be supplied with a nut and lock washer, but no probe. Recommended probe diameter and material of construction are shown in [Table 3-11](#). **When the no-probe option is selected, Honeywell does not guarantee transmitter performance.**

Table 3-11: Recommended probe diameter and material of construction

Model	Thread	Probe type	Recommended probe diameter	Recommended probe material
SLG720	M5x0.8	Rod	8mm	ASTM A-276, Type 316L, condition A or ASTM B574 alloy UNS N10276 solution annealed.
		Rope	4mm	ANSI T316 (7x7 construction)
SLG726	M10x1.5	Rod	16mm	ASTM A-276, Type 316L, condition
		Rope	4mm	ANSI T316 (7x7 construction)

3.2.5 Centering Disks and configured probe length

Centering disks are used to prevent the probe from contacting the wall in bypass or pipe installations. Centering disks are mounted directly to the end weight on wire probes. For the FEP coated wire probes, centering disks are mounted above the end weight.

Rod probes use a bushing and cotter pin to secure the centering disk to the probe. For the FEP coated rod probes, centering disks are recommended to be snapped 10mm above end of probe.

Note:

SLG720: One 3.5mm hole to be drilled into the end of the rod probe using a supplied drilling jig once the probe has been cut to length (if required).

- SLG720 PTFE application: No hole required.

See [Error! Reference source not found.](#)

SLG726: Require two 3.5mm holes.

See

Figure 3-17: Recommended location of holes for rod probes and Figure 3-18: Centering disks for wire and rod probes for recommended location of holes and assembly details of the centering disk. Secure the cotter pin by bending the leads back once installed. See

Table **3-12** and Table 3-13 for details.

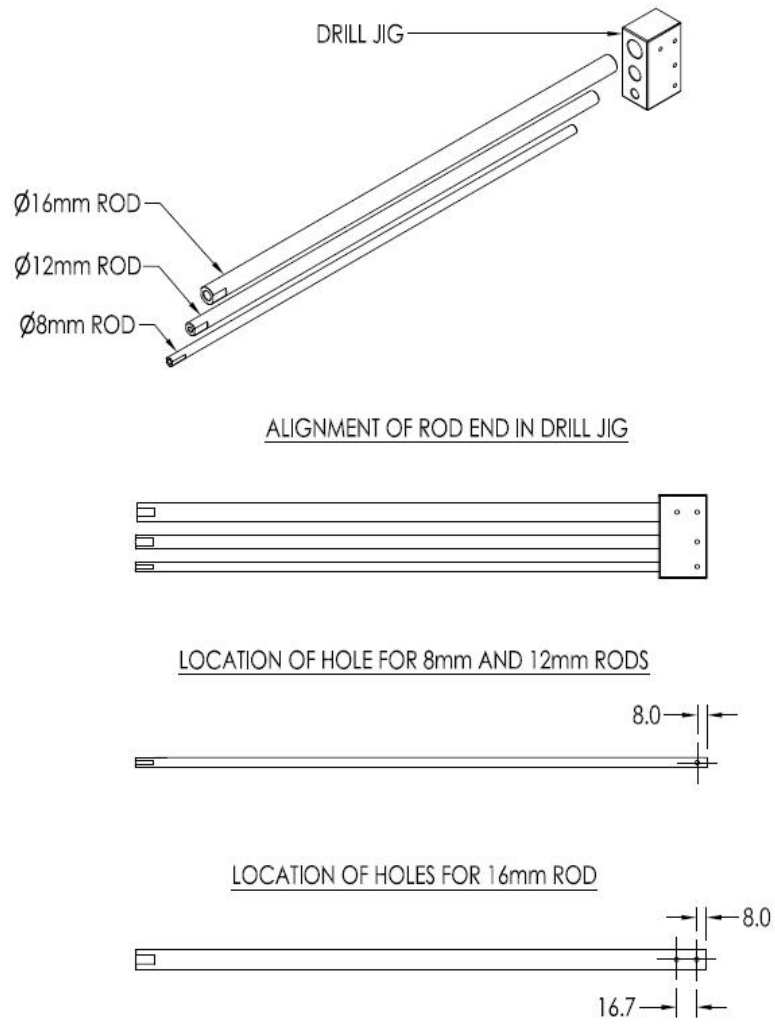

Figure 3-17: Recommended location of holes for rod probes

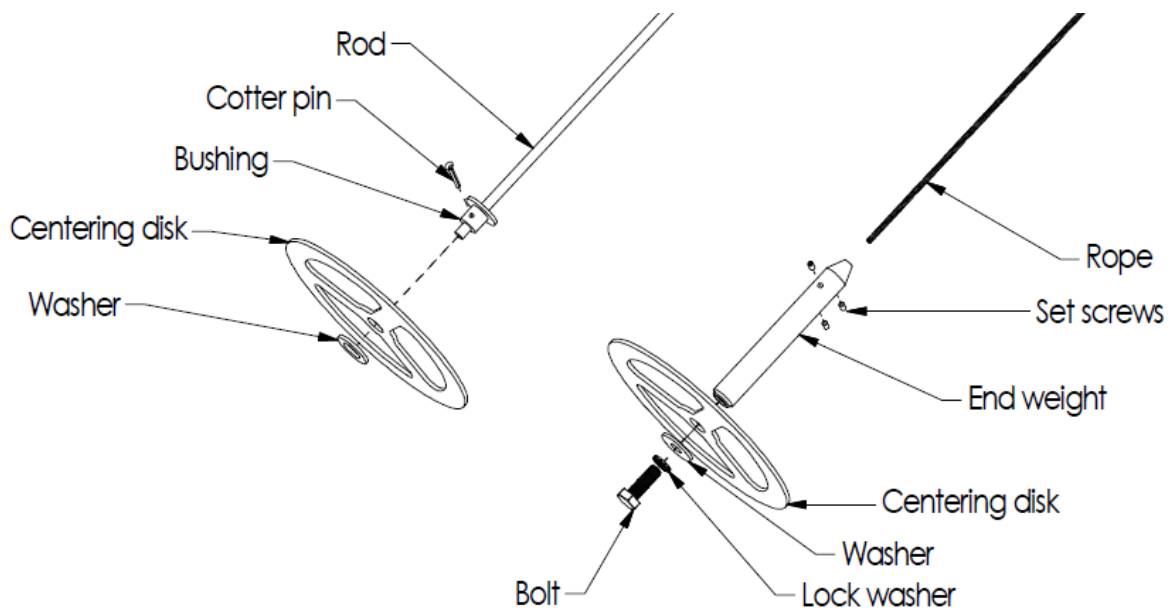

Figure 3-18: Centering disks for wire and rod probes.

Note: for Rod probe the cotter pin is placed underneath the disk and the washer to hold them in place.

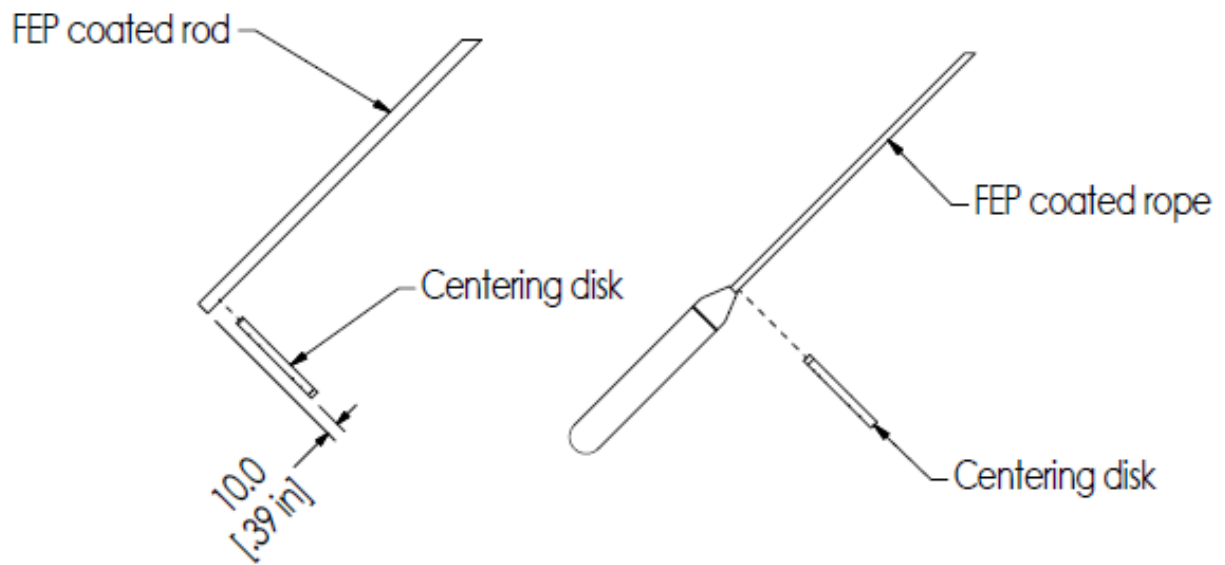

Figure 3-19: Centering disks for FEP coated wire and rod probes

Table 3-12: Centering disk determination from pipe size and schedule

Pipe size	Pipe schedule					
	5s,5	10s,10	40s,40	80s,80	120	160
2"	2"	2"	2"	2"	NA	NA
3"	3"	3"	3"	3"	NA	NA
4"	4"	4"	4"	4"	4"	3"
5"	4"	4"	4"	4"	4"	4"
6"	6"	6"	6"	6"	4"	4"
7"	NA	NA	6"	6"	NA	NA
8"	8"	8"	8"	8"	6"	6"

Table 3-13: Centering disk dimensions

Centering disk size	Actual disc diameter
2"	1.8" (45mm)
3"	2.7" (68mm)
4"	3.6" (92mm)
6"	5.5" (141mm)
8"	7.4" (188mm)

When a centering disk is added to a rod probe, a new probe length must be measured and configured in the transmitter. Failure to adjust the probe length and the probe termination configurations may lead to inaccurate readings close to the end of probe or/and may require the user to increase the blocking distance low. When using a centering disk with a rod probe, the probe length is defined as the distance from the flange (reference plane) to the top of the disk as shown in Figure 3-20: Probe length definition for rod probes using a centering disk. When using a wire probe, the probe length is independent of whether a centering disk is present or not as the probe length is defined as the distance from the flange (reference plane) to the top of the end weight.

Table 3-14: Probe length for different probe types

MODEL KEY	PROCESS CONNECTION TYPE	PROBE TYPE	LENGTH ENTERED INTO TRANSMITTER SOFTWARE
SLG 720	Flanged and Threaded	Rod and coaxial probes	L
		Wire probes	L - 150mm
SLG726	Flanged	Rod and coaxial probes	L
		Wire probes	L - 150mm
	Threaded	Rod and coaxial probes	L + 25mm
		Wire probes	L - 125mm

Note: "L" is the probe length specified in the transmitter model number

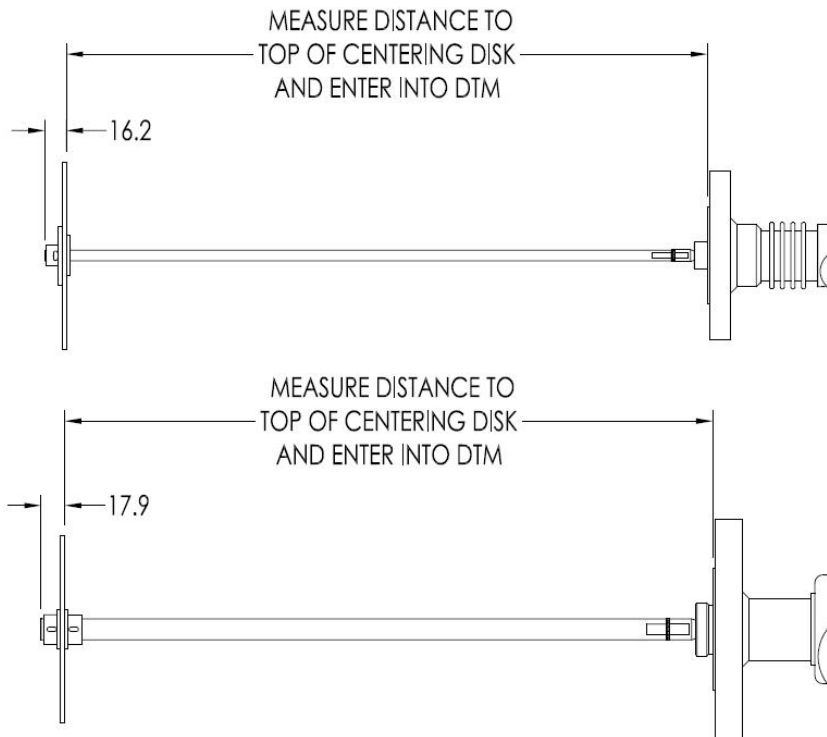

Figure 3-20: Probe length definition for rod probes using a centering disk

3.2.6 Mounting the transmitter

In the following dimension figures, “R” denotes the transmitter reference plane.

3.2.6.1 SLG720 Transmitter dimensions

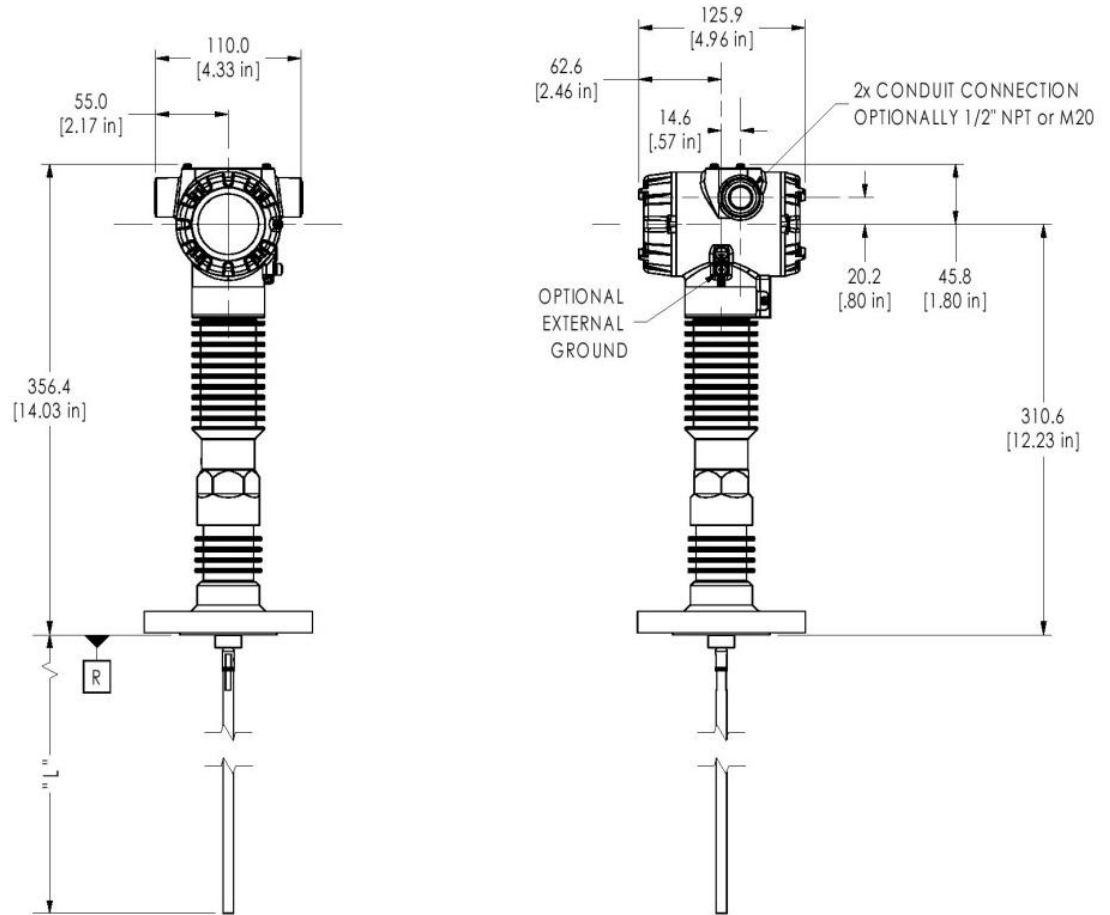

Figure 3-21: Flanged SLG720 Transmitter, mm [in]

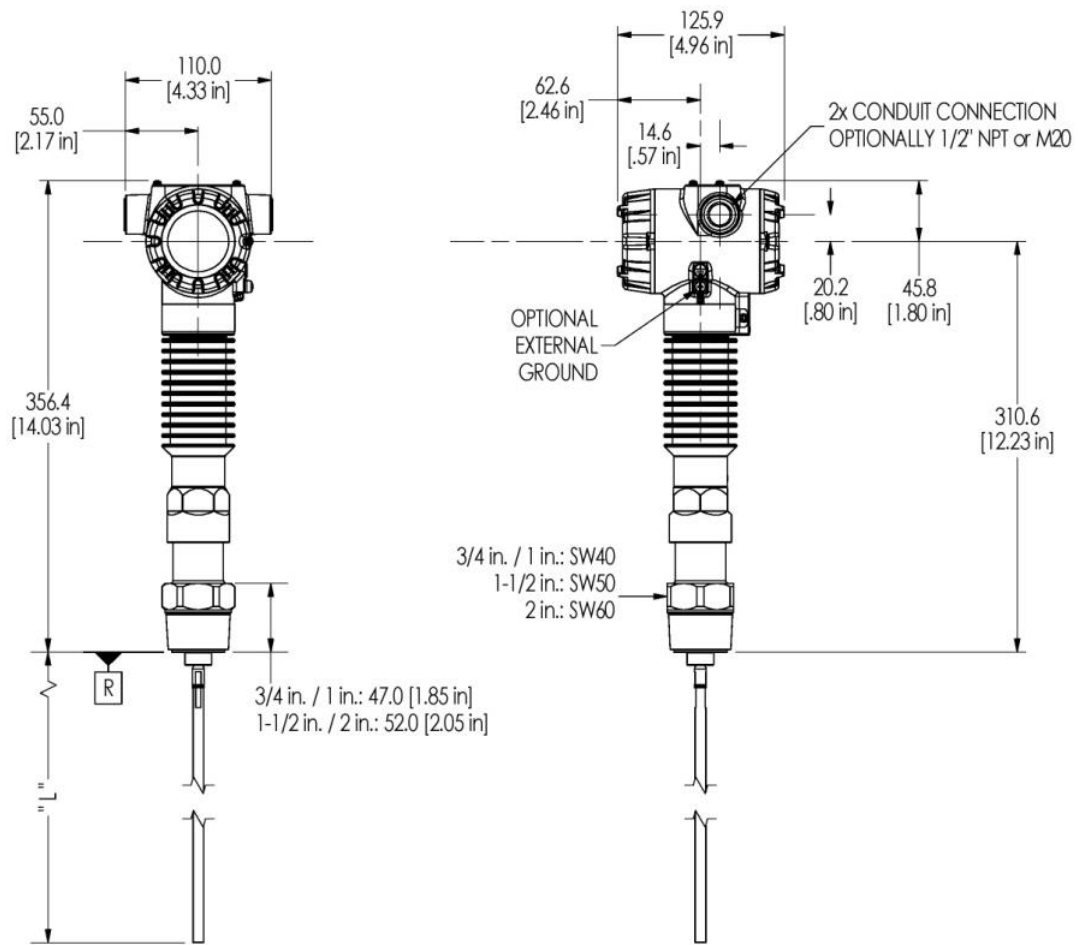

Figure 3-22: Threaded (NPT 3/4", 1", 1 1/2", 2") SLG720 Transmitter, mm [in]

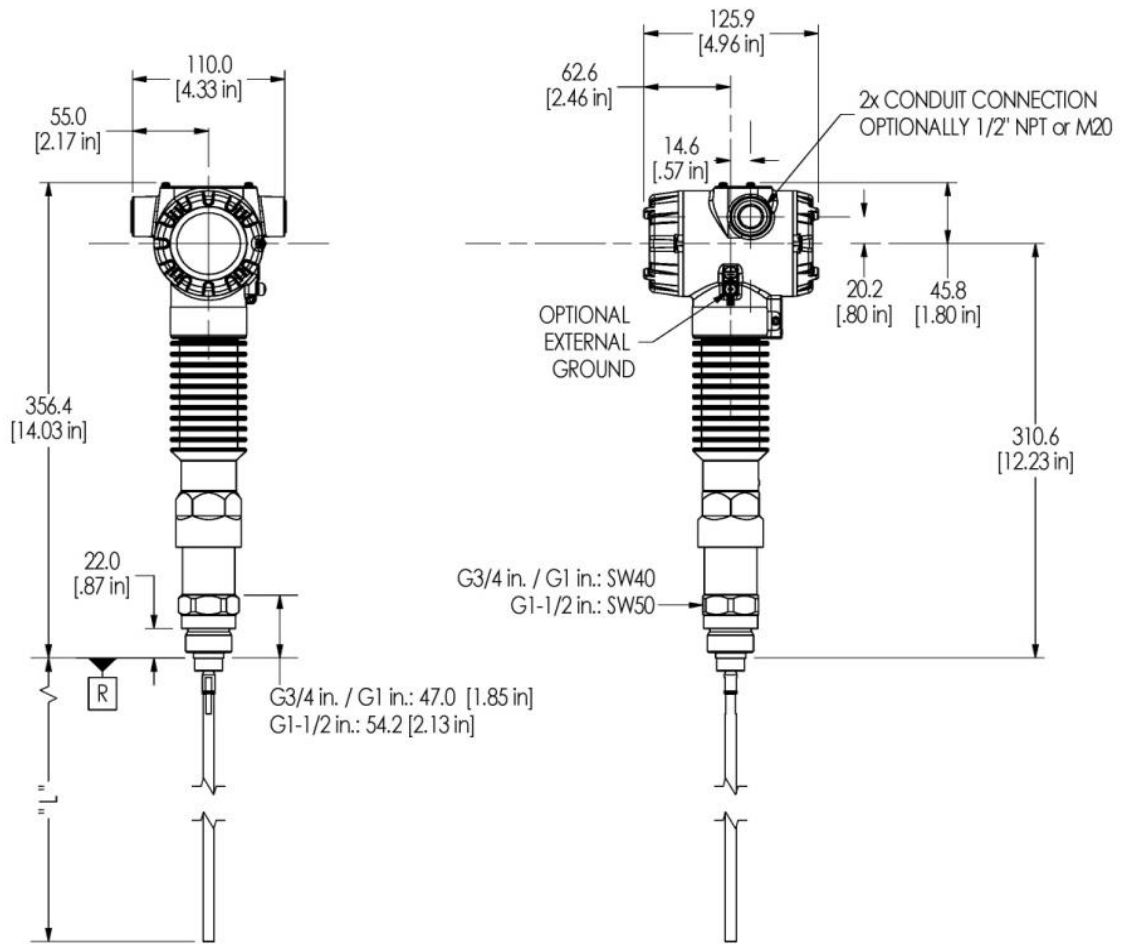

Figure 3-23: Threaded (BSP/G 3/4", 1", 1 1/2") SLG720 Transmitter, mm [in]

3.2.6.2 SLG726 Transmitter dimensions

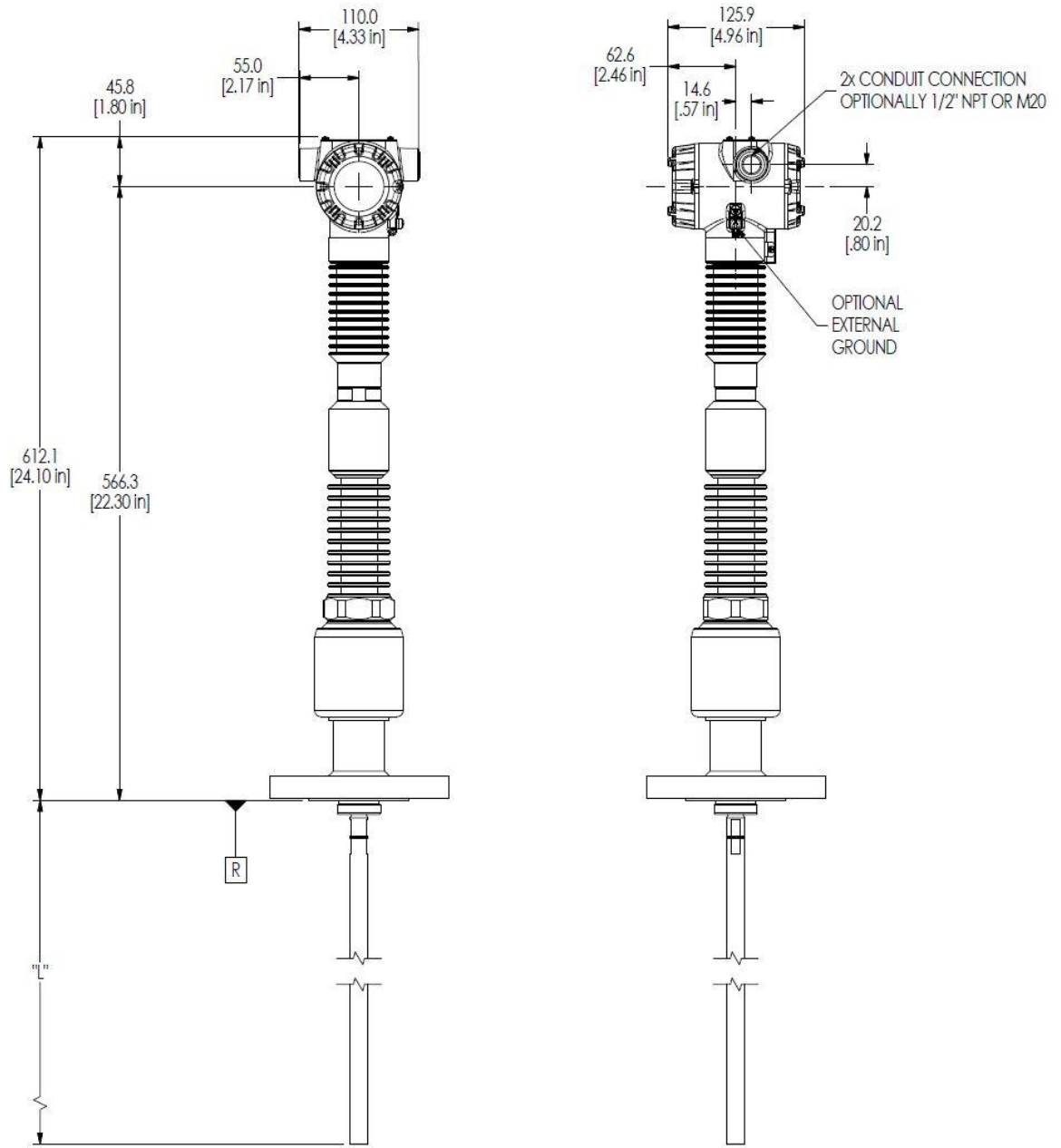

Figure 3-24: Flanged SLG726 transmitter, mm [in]

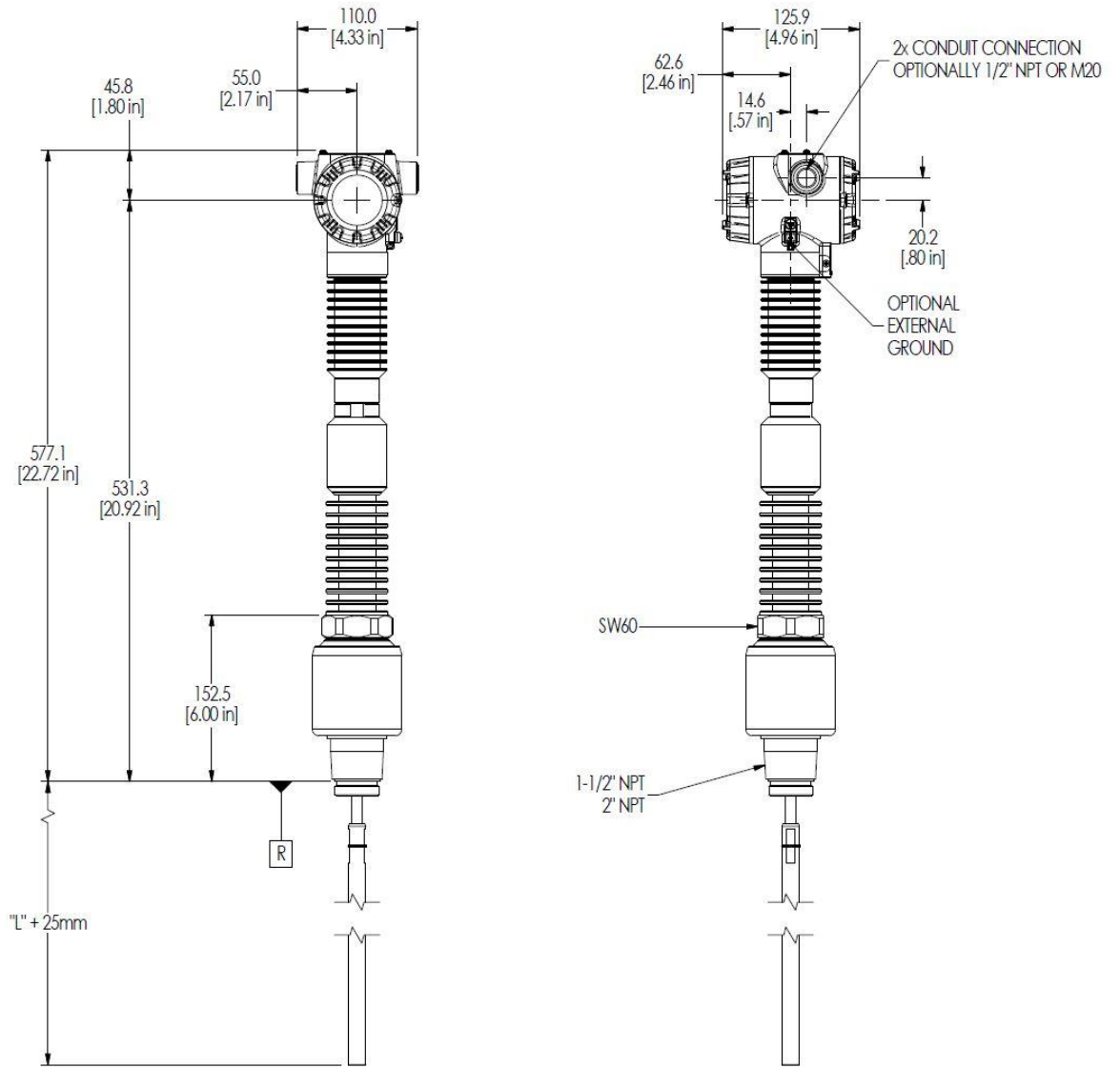

Figure 3-25: Threaded (NPT 1½", 2") SLG726 transmitter, mm [in]

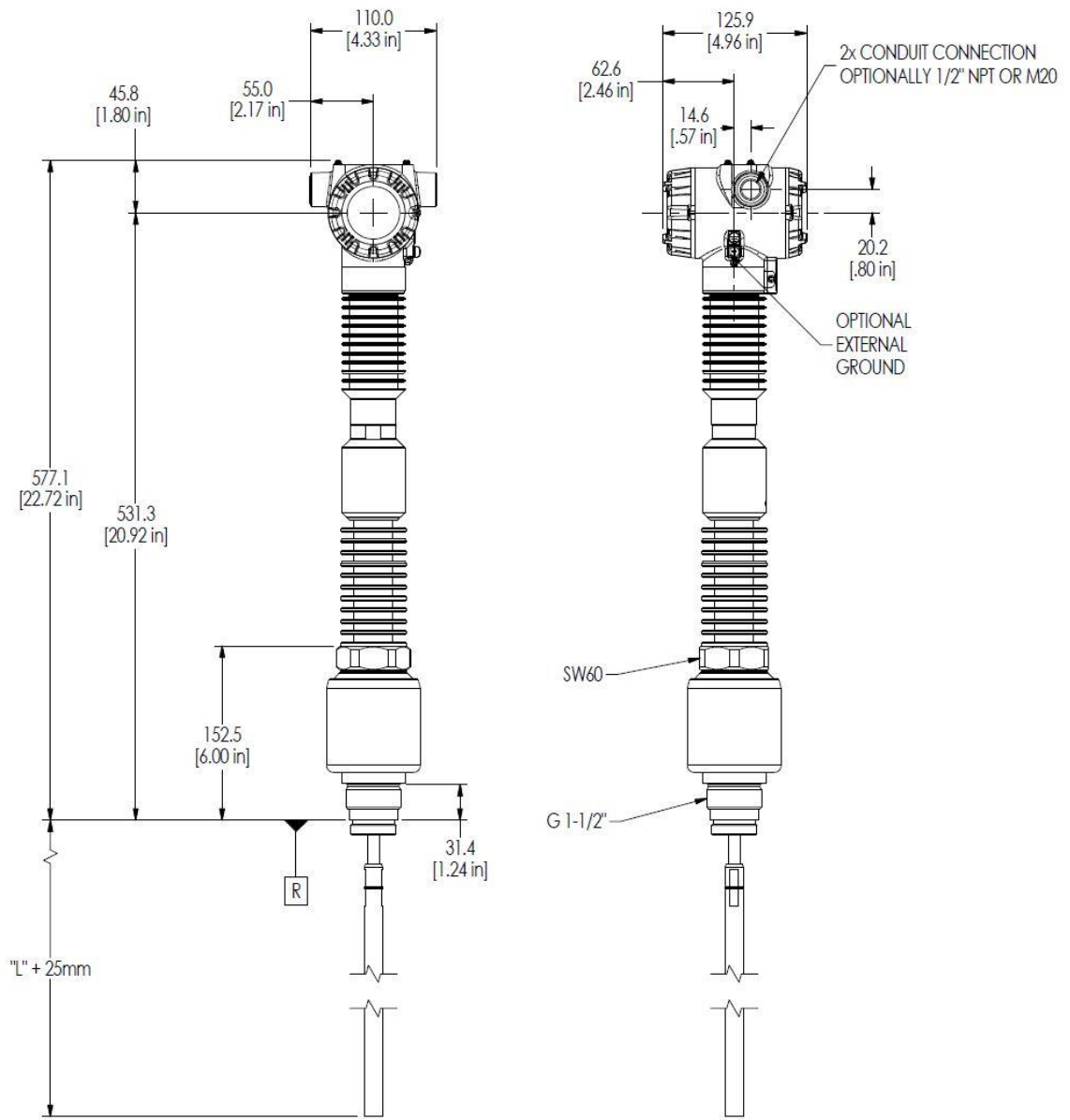

Figure 3-26: Threaded (BSP/G 1½") SLG726 transmitter, mm [in]

3.2.7 Suitable mounting position

To minimize signal interference, observe the minimum distances in Table 3-15.

Examples of obstacles to avoid are protruding welds, internal installations, agitators, pipes and nozzles extending into the container, heating coils, inlet streams, ladders, etc. Metallic objects are a source of bigger interferences than non-metallic objects.

Turbulent applications may require the probe to be anchored to prevent it from contacting or getting too close to container walls or obstacles.

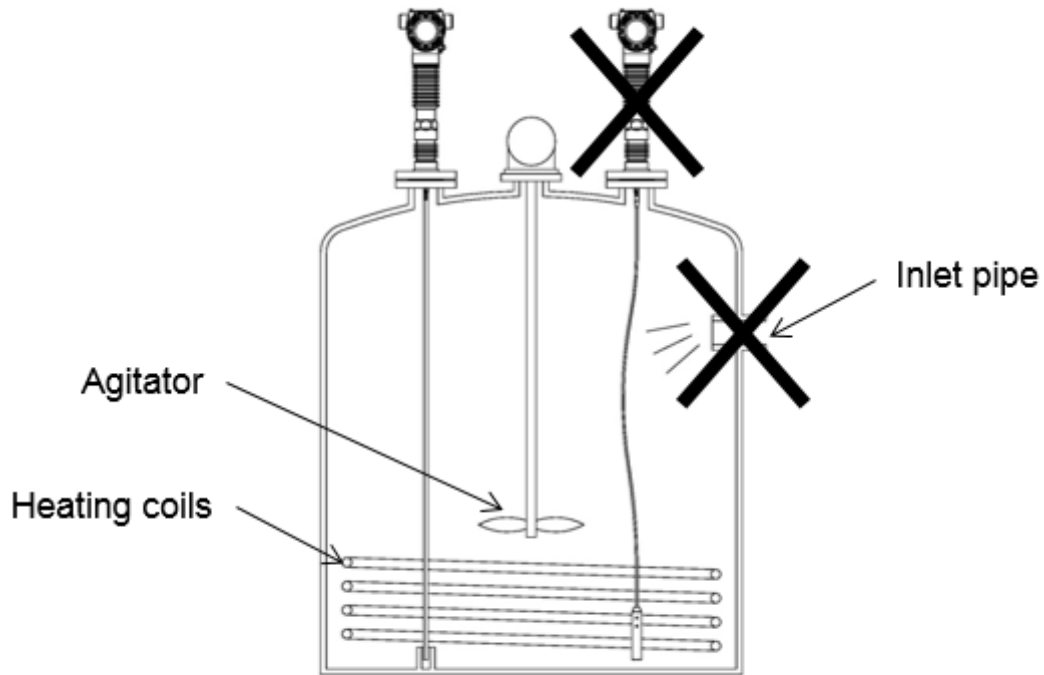

Figure 3-27: Mounting position

Table 3-15: Minimum recommended distance to container wall and obstacles (mm)

Probe	Minimum distance to obstacle	Minimum distance to metallic container wall	Minimum distance to non-metallic container wall
Single wire	500mm (20")	100mm (4")	500mm (20")
Single rod	500mm (20")	100mm (4")	500mm (20")
Coax	0mm (0")	0mm (0")	0mm (0")

3.2.8 Optimum Operating Temperature

3.2.8.1 Overview

When you deviate from reference conditions some of the SLG720/726 specifications can be sub-optimal and the upper and lower blocking distances may need to be increased at the operating temperature extremes. The document outlines a few options to maintain best operation at temperature.

3.2.8.2 Transmitter Behavior at Temperature

All the PCBAs except the display of the SmartLine Guided Wave Radar (GWR) Level Transmitter are rated to operate within a temperature range from -40°C to 85°C . The display is rated to operate to a maximum of 70°C . Also, note that for intrinsically safe (IS) installations the maximum allowable operating temperature for all SmartLine transmitters is 70°C . At high temperatures, the pulse may change slightly from its ambient shape. A consequence is that a field background obtained at the lower temperature reference conditions may not be accurate and cause incorrect processing of the data, especially at the start of the probe.

The purpose of this note is to outline recommendations when operating the GWR level transmitter with electronics temperature above 60°C or below -20°C .

Note if the transmitter electronics is above 60°C because of radiative heating from the sun it may be possible to reduce the temperature below 60°C by installing a shield to shade the transmitter.

3.2.8.3 Reconfiguration Instructions

Depending on the application and customer preferences, there are a number of options for optimizing measurement performance at temperature effects when the level is near the process connector.

1. Turn off full tank detection* especially when the dielectric constant is less than 12. Refer to the *SLG 700 HART option manual 34-SL-25-06* or the *SLG 700 FOUNDATION Fieldbus manual 34-SL-25-07*. This disables the software from detecting a reflection close to the process connector inside the blocking distances.
2. Enable Dynamic Background updating. This feature allows the sensor to automatically update the background echo profile every 10°C or every few hours as long as the level is reliably detected and of sufficient distance from the process connector. If the level is consistently within 30cm of the process connector however, no update can be performed. Note that the updated backgrounds are permanently stored on the sensor and are reloaded after a reset.
3. Options 1 and 2 above should always take care of any temperature effects but it can also help if a field or obstacle background at or near the operating temperature of the device can be taken. Backgrounds can be taken using the Honeywell DTM, the local display, or the supported handhelds. The DTM instructions can be found in the *SLG 700 HART option manual 34-SL-25-06*.

3.2.9 Temperature requirements

Thermal loading from the process and ambient environment affects the temperatures of the electronics, as well as the seals inside the level transmitter. Figure 3-28: SLG720 temperature limits defines the limits of ambient and process temperatures as they pertain to specific seal materials in the transmitter.

The SLG726 (high pressure high temperature (HTHP) process connector) must be pressure de-rated at elevated temperatures. The pressure rating at operating temperature is specified in Figure 3-30: SLG726 Maximum pressure based on maximum operating temperature and in tabular form in [Table 3-16](#).

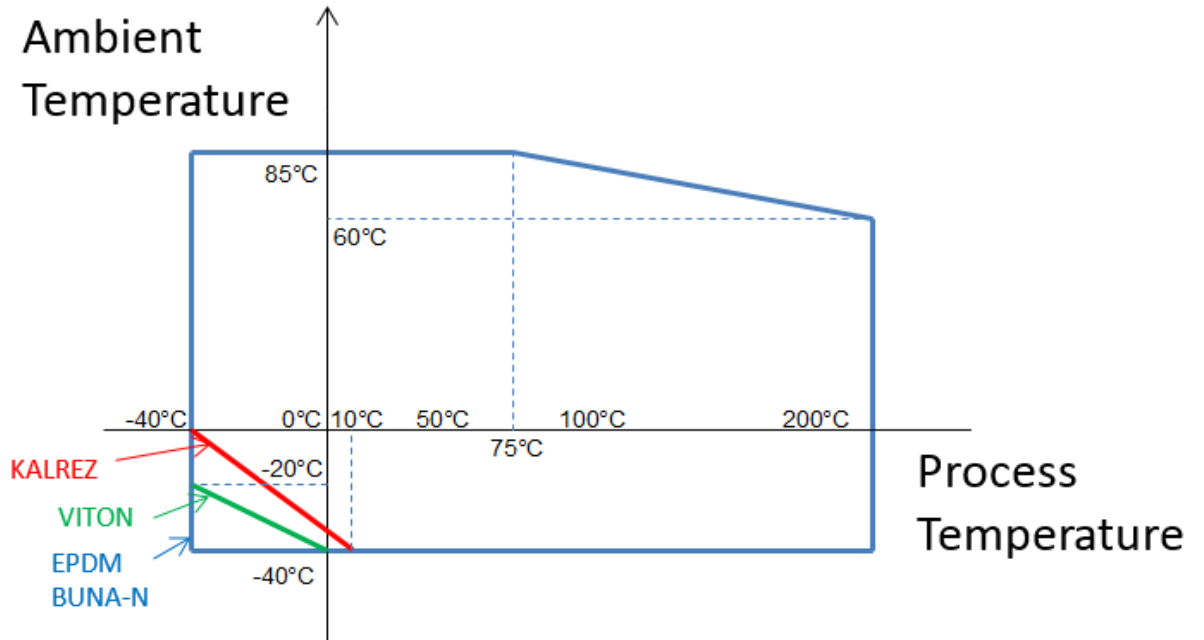

Figure 3-28: SLG720 temperature limits

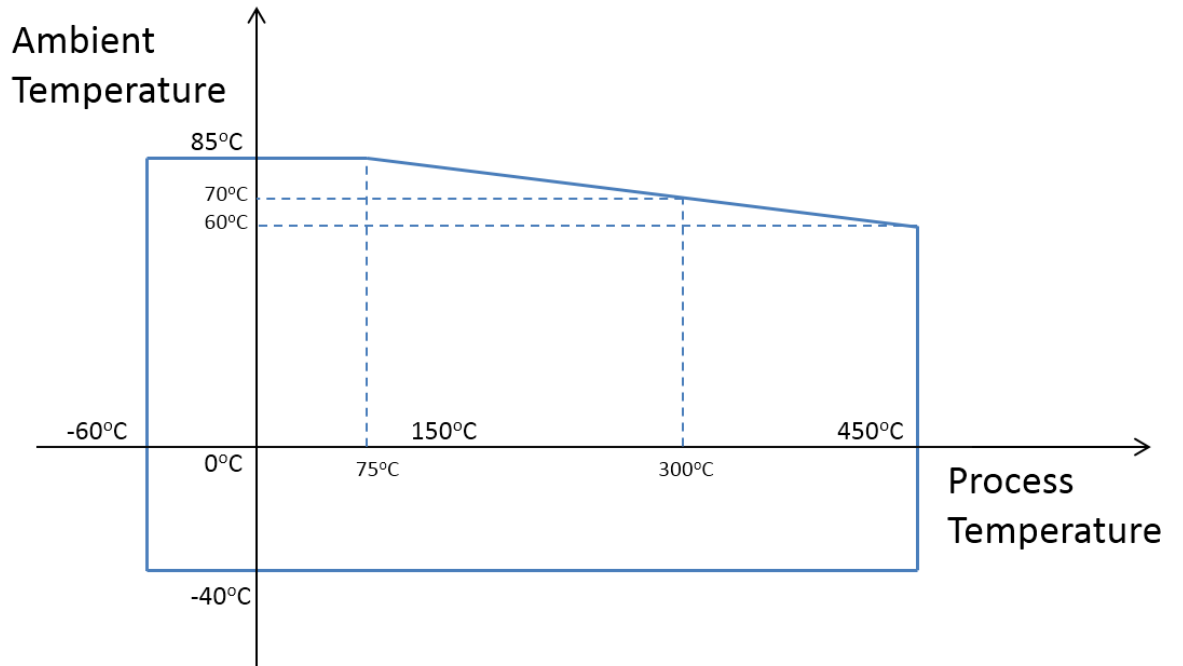

Figure 3-29: SLG726 temperature limits

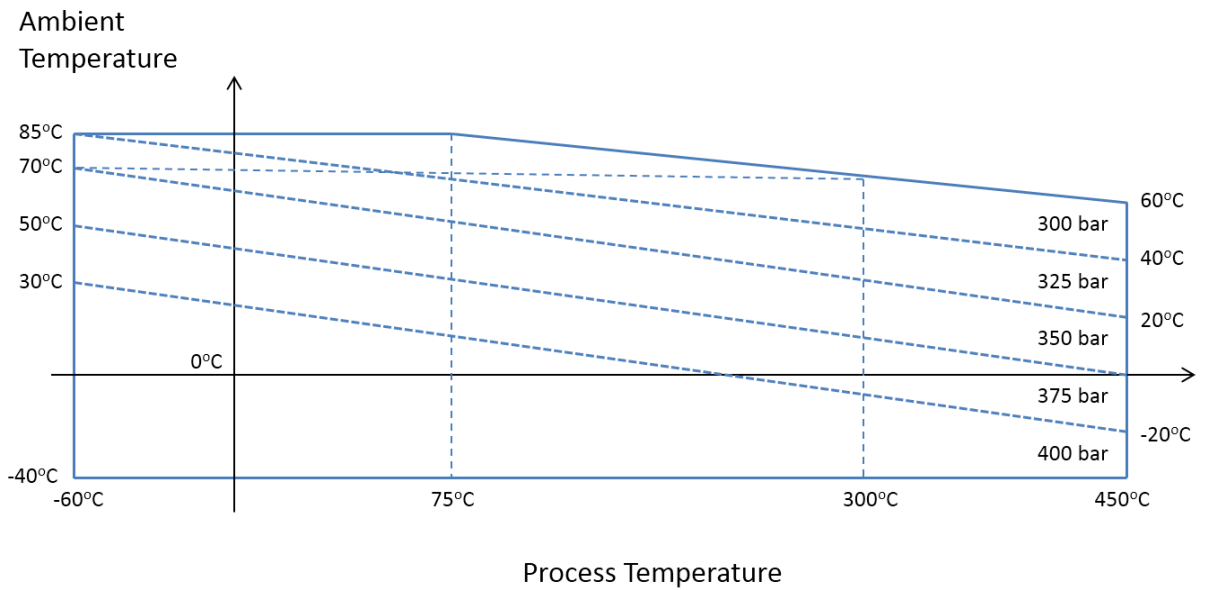

Figure 3-30: SLG726 Maximum pressure based on maximum operating temperature

Table 3-16: SLG726 Maximum pressure based on maximum operating temperature in tabular form

MAX PRESSURE [bar]		AMBIENT TEMPERATURE [°C]													
		-40	-30	-20	-10	0	10	20	30	40	50	60	70	80	85
PROCESS TEMPERATURE [°C]	-60	400	400	400	400	400	400	400	400	375	375	350	350	325	325
	-50	400	400	400	400	400	400	400	400	375	375	350	350	325	325
	0	400	400	400	400	400	400	400	375	375	350	350	325	325	300
	50	400	400	400	400	400	400	400	375	375	350	350	325	300	300
	100	400	400	400	400	400	400	375	375	350	350	325	325	300	-
	150	400	400	400	400	400	400	375	375	350	350	325	325	300	-
	200	400	400	400	400	400	375	375	350	350	325	325	300	-	-
	250	400	400	400	400	400	375	375	350	350	325	325	300	-	-
	300	400	400	400	400	375	375	350	350	325	325	300	300	-	-
	350	400	400	400	400	375	375	350	350	325	325	300	-	-	-
	400	400	400	400	375	375	350	350	325	325	300	300	-	-	-
450	400	400	400	375	375	350	350	325	325	300	300	-	-	-	
INTRINSICALLY SAFE (IS)													NON-(IS)		

3.2.9.1 *Flange mount*

To mount a flanged transmitter, bolt the transmitter's flange to the flange on the tank.

Step	Action
1	On insulated tanks, remove enough insulation to accommodate the flange extension. Note: It is the End User's responsibility to provide a flange gasket and mounting hardware that are suitable for the transmitter's service condition.
2	Ensure correct functionality: To ensure a reliable electrical contact between the tank and transmitter, use unpainted, metal bolts.

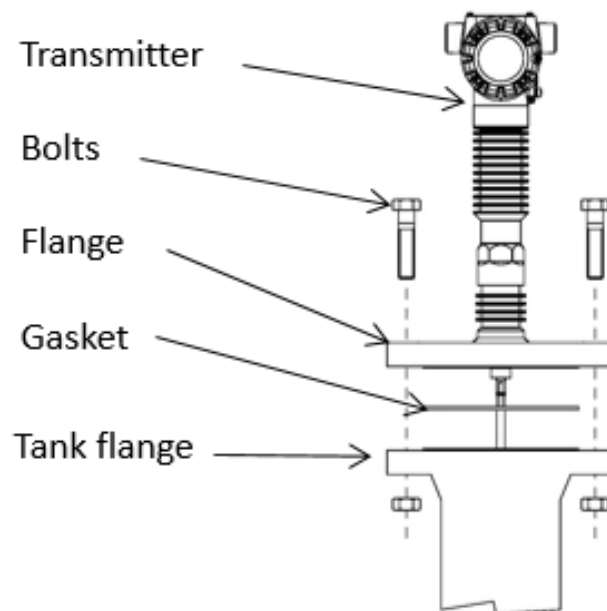

Figure 3-31: Flanged tank connection

3.2.9.2 Nozzle mount

The transmitter can be mounted to a tank nozzle using the appropriate flange. [Table 3-17](#) shows recommended nozzle dimensions based on probe type.

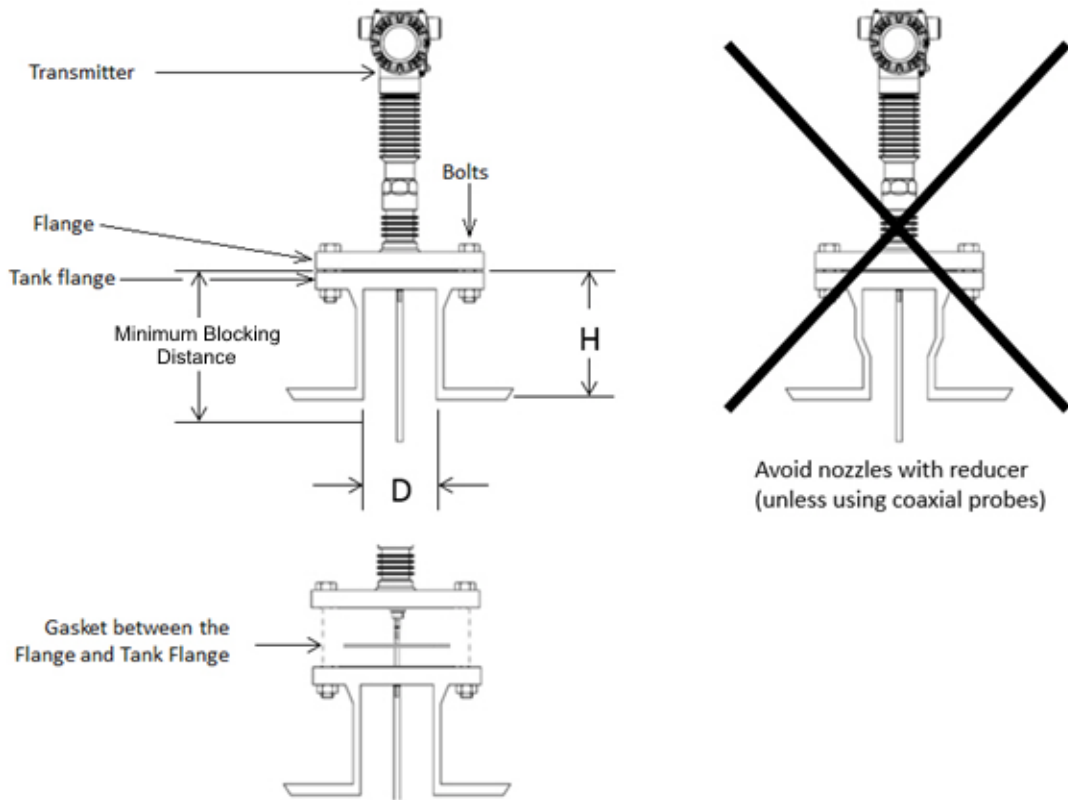

Figure 3-32: Flange mounting

Table 3-17: SLG720: Recommended nozzle dimensions

	Single probe (rod/wire)	Coaxial probe
Recommended nozzle diameter (D)	6" (150mm)	> probe diameter
Minimum nozzle diameter (D)	2" (50mm)	> probe diameter
Recommended nozzle height (H)	4" (100mm) + nozzle diameter (*)	N/A
(*) When using a flexible probe in nozzles taller than 6" (150mm) the SWB wire probe with extension stud is recommended. SWB is an option in the model selection guide. It offers a 300mm rod extension to keep the section of the wire probe that is in the nozzle, from moving.		

In certain applications, taller nozzles may be accommodated but near zone performance at the exit of the nozzle may be reduced. For nozzle dimensions that do not meet the requirements outlined in [Table 3-17](#) contact the Honeywell Technical Assistance Center.

Area	Organization	Phone Number
United States and Canada	Honeywell Inc.	1-800-343-0228 Customer Service 1-800-423-9883 Global Technical Support
Global Email Support	Honeywell Process Solutions	hfs-tac-support@honeywell.com

For single lead probes, avoid nozzles > 8" (200 mm) in diameter nozzles, particularly when measuring low dielectric constant materials. The user will need to install a smaller inner nozzle when operation with these larger nozzle diameter required, see Figure 3-33: Oversized nozzle configuration for inner nozzle design requirements.

For supported nozzles, the minimum upper blocking distance and transition zone distance must be increased by the height of the nozzle. Additionally, in order to achieve the minimum upper blocking distance as well as meet the accuracy specification in the upper transition zone, a field background must be performed.

3.2.9.3 Nozzles diameter > 8" (200 mm)

Where an 8" nozzle (or greater) is the only installation option, use Figure 3-34: Threaded tank connection as a guideline.

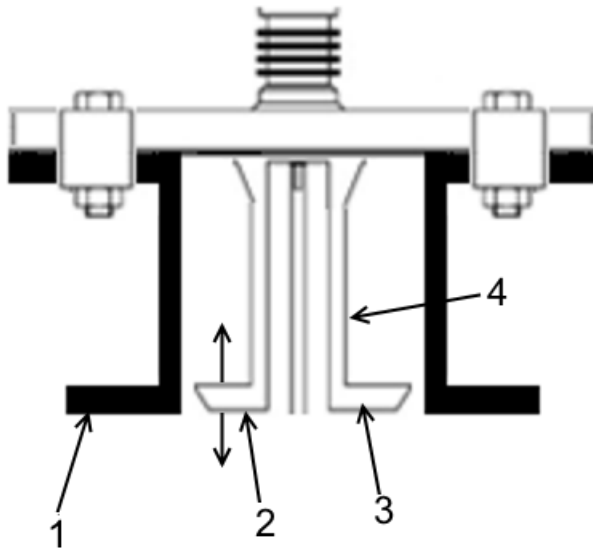

- 1 Nozzle lower edge
- 2 Plate approximately flush with lower edge of the nozzle
- 3 Pipe
- 4 Pipe diameter 150mm (6"). Where 1 = 8" diameter

Figure 3-33: Oversized nozzle configuration

3.2.9.4 *Threaded mount*

Transmitters with threaded process connectors can be screwed to tanks or nozzles with threaded bosses. For tanks with BSP/G threads, place a gasket on top of the tank, or use a sealant on the threads of the tank connection.

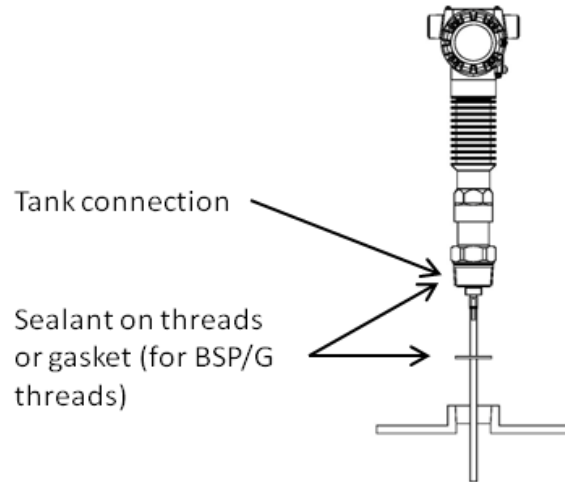

Figure 3-34: Threaded tank connection

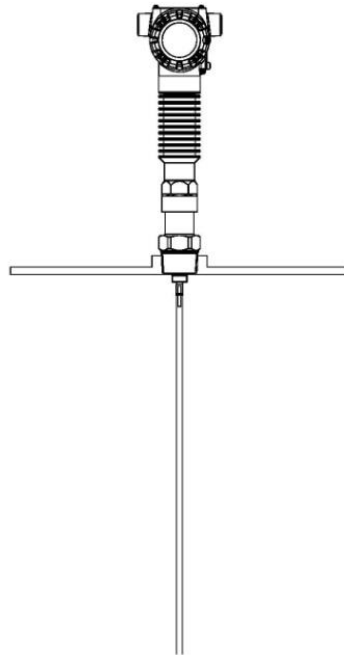
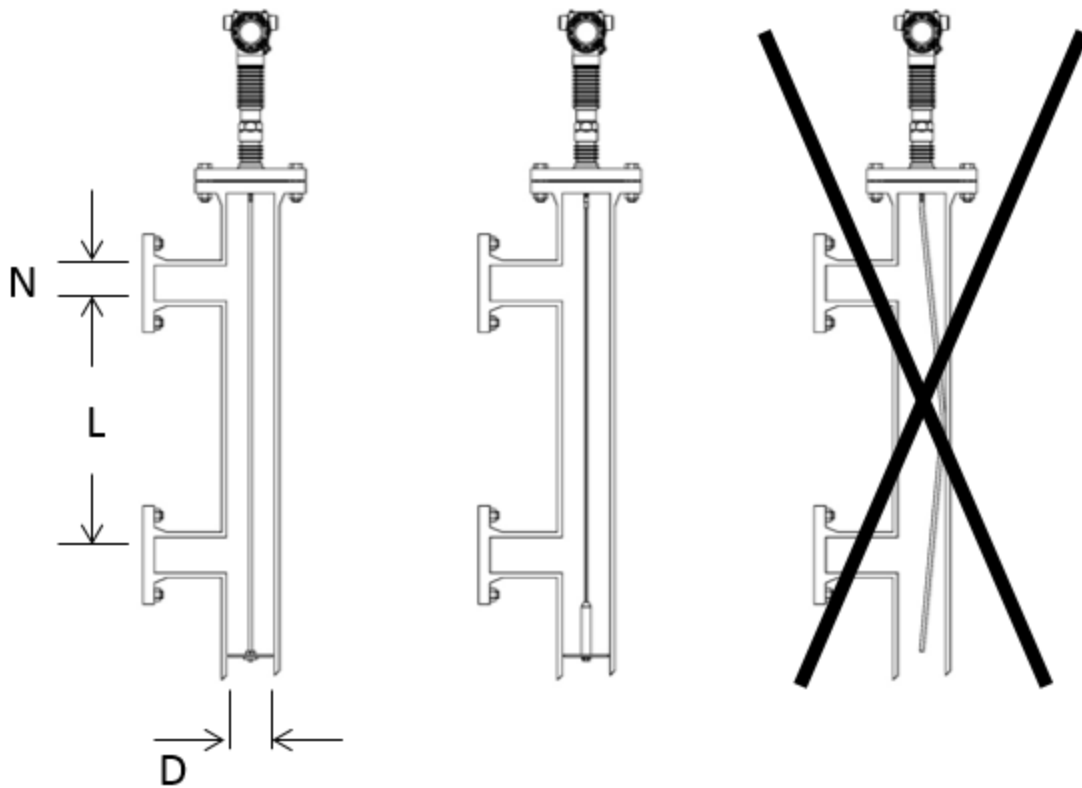

Figure 3-35: Tank roof mounting using threaded connection

3.2.9.5 **Mounting on a bypass / bridle**

SLG 700 transmitter can be successfully installed in a new or existing bypass pipe, bridle, or a side pipe as shown Figure 3-36: Bypass installation. This type of installation is often simpler and allows the addition of radar level measurement to an otherwise busy installation.

A similar installation is also possible inside the main container, when installing the SLG 700 transmitter on a stilling well.



- N = Inlet diameter
- L = Effective measurement range ($\geq 12''/300\text{mm}$)
- D = Bypass diameter ($N < D$)

Figure 3-36: Bypass installation

Table 3-18: SLG720 bypass and stillwell recommended diameters

Probe type	Recommended diameter	Minimum diameter
Rod probe	3" or 4" (75mm or 100mm)	2" (50mm)
Wire probe	4" (100mm)	2" (50mm)

Coaxial probe	N/A	1.5" (37.5mm)
---------------	-----	---------------

Table 3-19: SLG726 bypass and stillwell recommended diameters

Probe type	Recommended diameter	Minimum diameter
Rod probe	3" or 4" (75mm or 100mm)	2" (50mm)
Wire probe	4" (100mm)	2" (50mm)
Coaxial probe	N/A	2" (50mm)

Chambers with smaller diameter can lead to problems with build-up. Chambers larger than 6" (150mm) can be used, but offer little advantage for radar measurement.

The probe must extend the full length of the chamber and not contact the bottom of the chamber, or make contact with the chamber wall.

Clearance from the bottom of the chamber is recommended to be 1" (25mm). Probe selection is dependent on length.

For lengths less than 20' 8" (6.3m): Rod probe is recommended.

For lengths more than 20' 8" (6.3m): Wire probe with weight and centering disk is recommended.

A centering disc is recommended for rigid probes over 1-m length to prevent excessive movement caused by strong currents inside the pipe.

For saturated steam applications refer to Table 2-1.

3.2.10 Mounting on a non-metallic container

To install a single lead probe into a non-metallic (plastic) vessel, the probe must be mounted with a metal flange (>2"/DN50) or if a threaded process connection is in use, the probe must be screwed into a metal sheet (diameter > 8"/200mm).

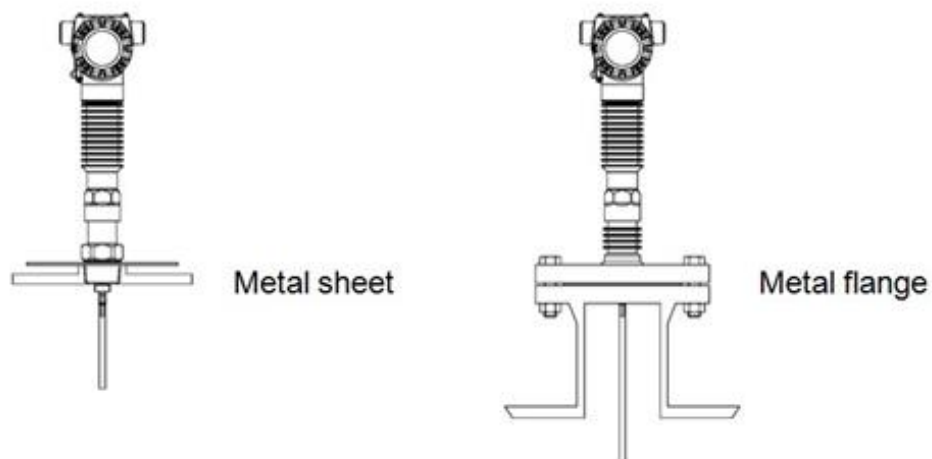

Figure 3-37: Mounting on a non-metallic vessel

Figure 3-38 depicts an example of mounting in concrete silos, the placement of the concrete versus the metal sheet used to secure the transmitter. Both Figure 3-37 and Figure 3-38 are considered non-metallic mounts. Both types of mountings are subject to the same specifications.

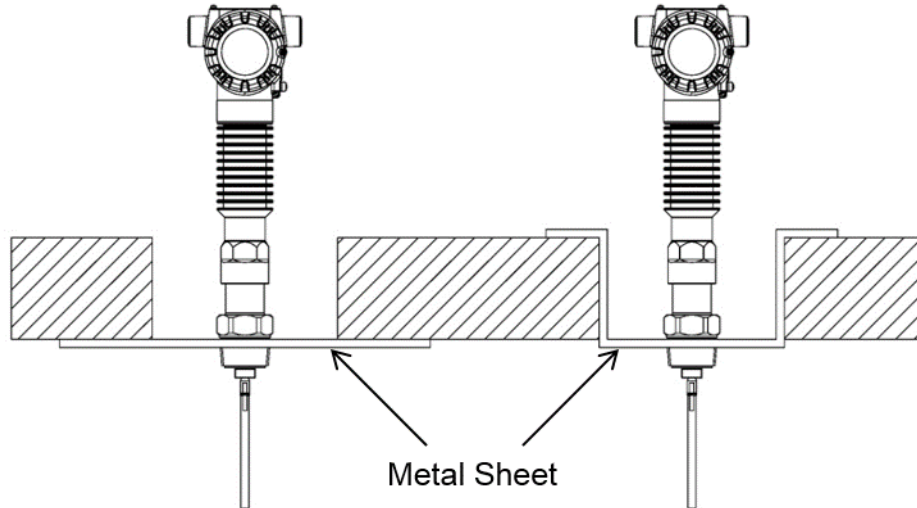

Figure 3-38: Mounting in concrete silos

3.2.10.1 *Remote mount*

In applications where a remotely mounted display is required, the remote mount allows the electronics housing to be mounted 3-m away from the process connector. This can be useful when access to the mounting location is limited. To assemble the remote mount, mount the process connector to the tank first, then secure the mounting bracket to a pipe or wall. Secure the electronics module to the bracket with the 3 supplied M6 screws. Connect the cable and check bends for minimum radius (see Figure 3-39) to prevent damage. Torque the 2 nuts to 6Nm (4.4ft-lbs). Note that if separating the cable from the process connector or the electronics, care must be taken to avoid damaging the o-rings. O-ring lubricant may help to avoid damage.

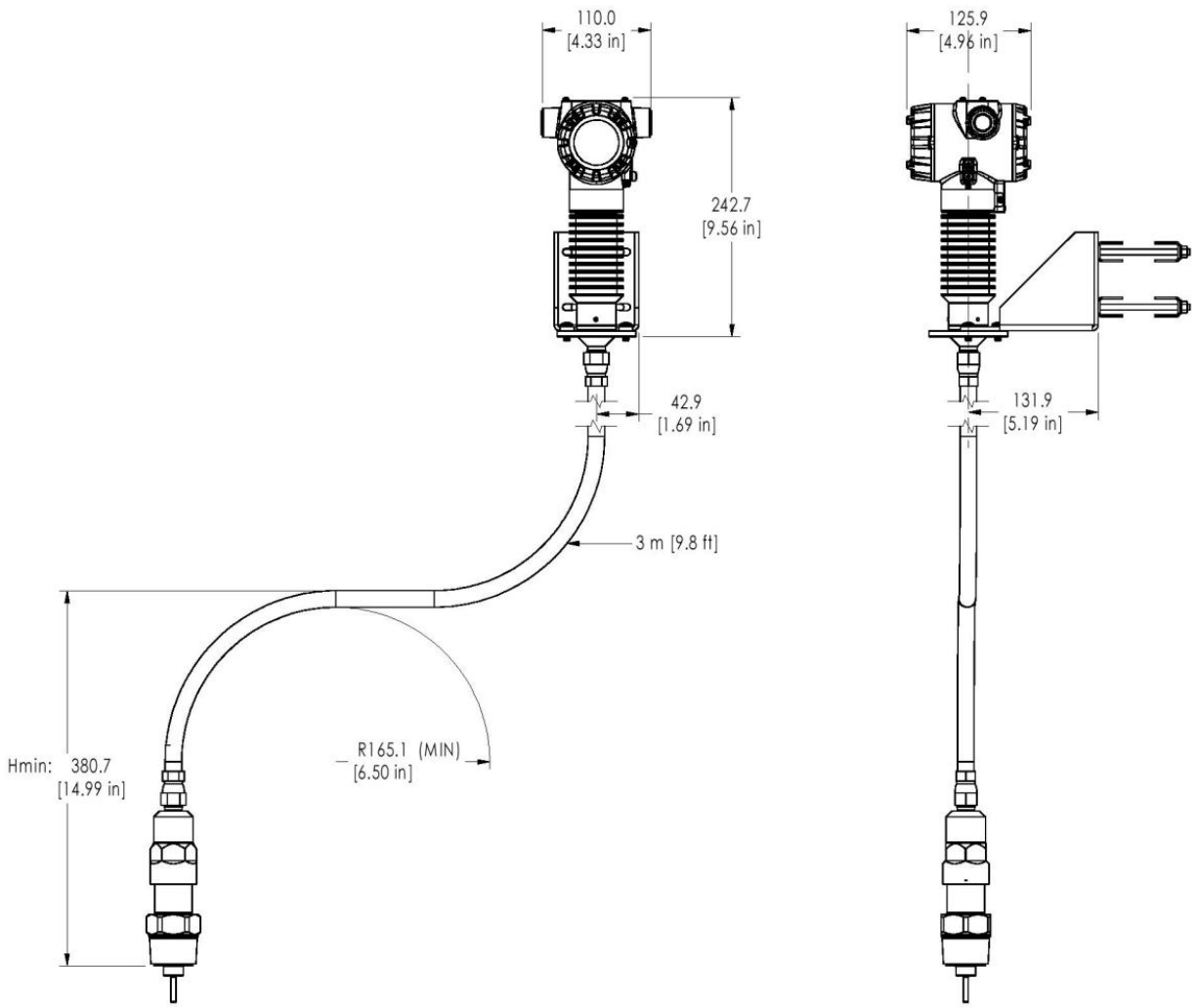
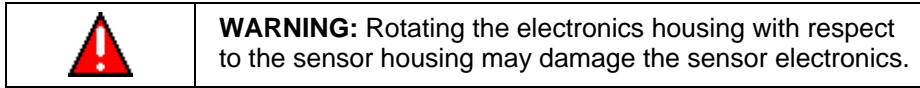

Figure 3-39: Remote mount

3.2.11 Rotate transmitter housing



Once installed, the transmitter housing can be rotated to the desired orientation by loosening the two setscrews on the sensor housing and then rotating the sensor electronics with respect to the process connector.

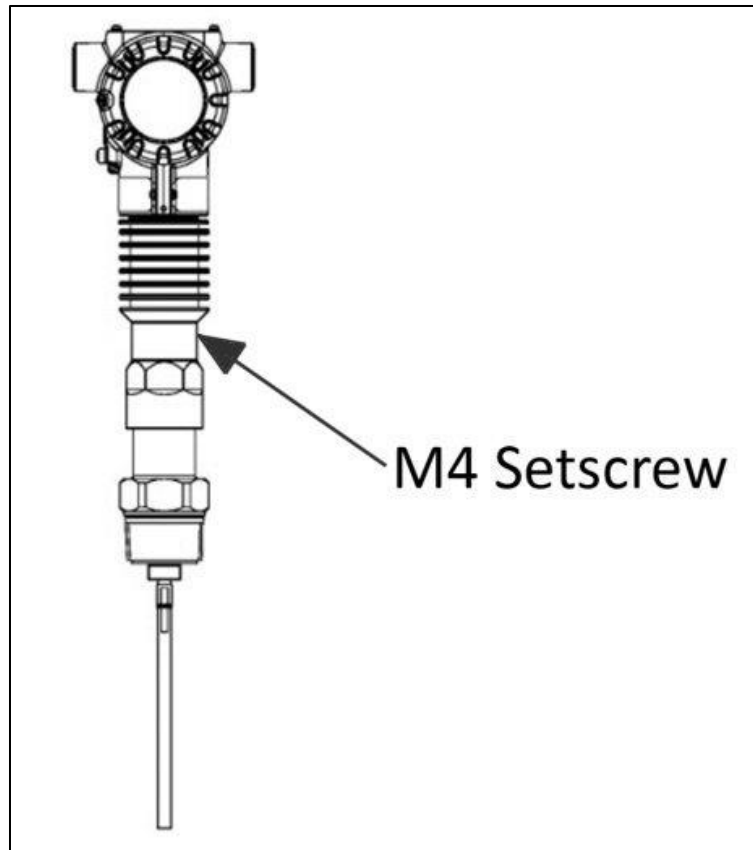

Figure 3-40: Rotate transmitter housing

3.2.12 Secure the probe

In tanks with turbulence, it may be necessary to secure the probe to the tank to prevent probe damage, or contact with the tank wall. Depending on probe type, different methods can be used. For wire probes with end weights, the end weight has an internal M10x1.5 thread. This thread can be used to attach mounting hardware such as an eyebolt for example (customer supplied). Alternatively, the weight can be removed and a rope clamp can be used to form a loop at the end. See Figure 3-41.

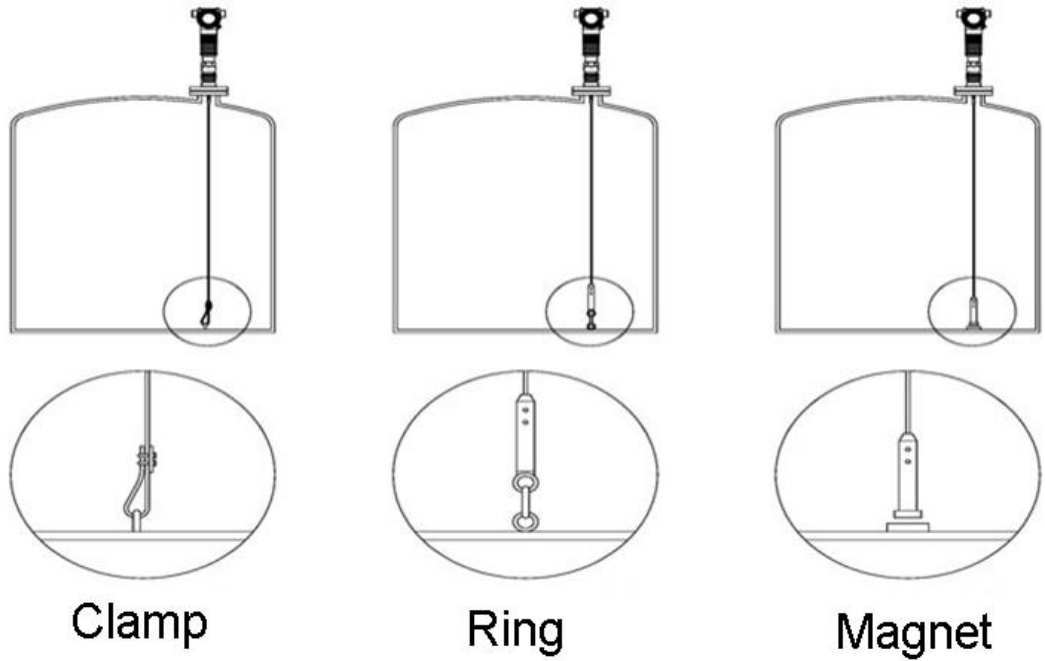

Figure 3-41: Anchoring wire probes

When anchoring a wire probe it is recommended that the wire be slack to prevent excessive tensile loading from motion of medium and/or thermal expansion. The sag should be $\sim 1\text{cm/m}$ ($1.5''/10'$) of the probe length. See Figure 3-42.

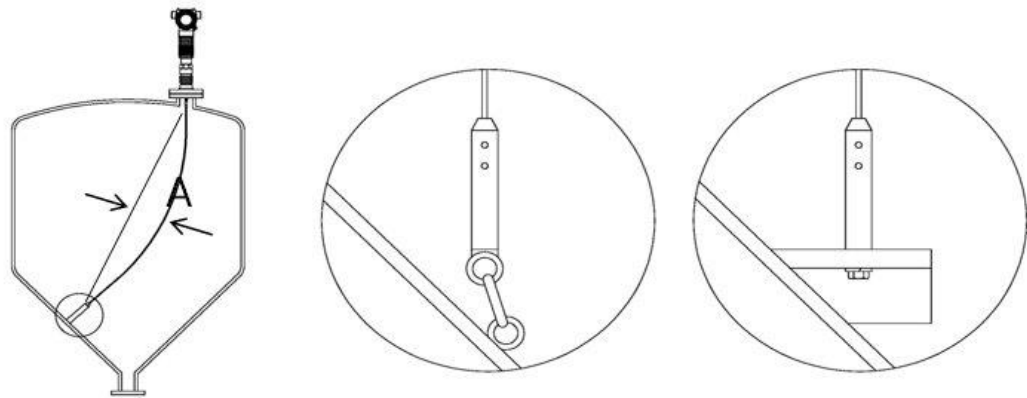

Figure 3-42: Wire probe slack

Coaxial probes can be anchored along their length. Ensure that the probe can move freely along its length to allow for thermal expansion.

Thermal coefficient of expansion = $16 \times 10^{-6} \text{ m/m-}^\circ\text{K}$

Coaxial probes can be guided by a tube welded to the bottom of a tank. Make sure that the coaxial probe can move freely to allow for thermal expansion.

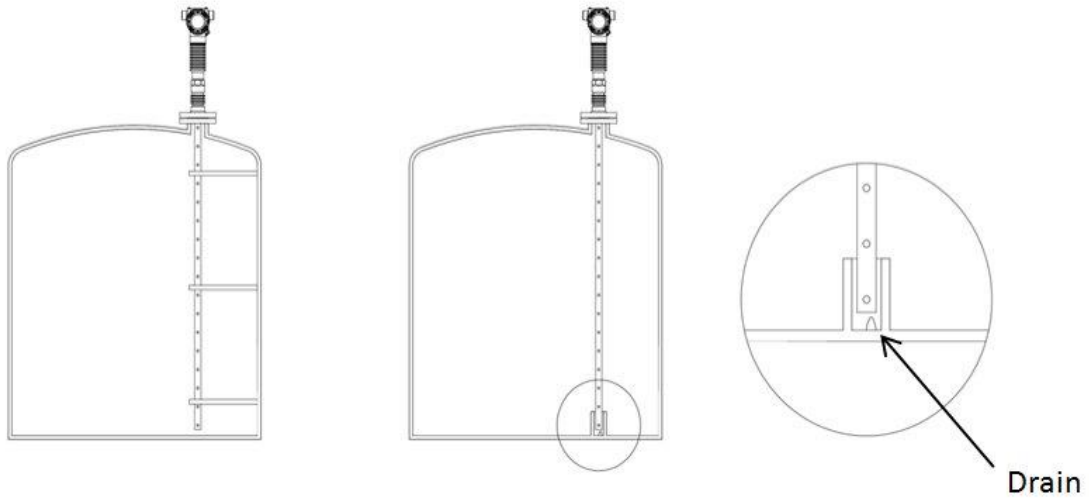

Figure 3-43: Anchoring coaxial probes

3.2.13 Install conduit entry plugs and adapters

NOTICE	<p>THE CONDUIT/CABLE GLAND ENTRIES OF THIS PRODUCT ARE SUPPLIED WITH PLASTIC DUST CAPS WHICH ARE NOT TO BE USED IN SERVICE.</p> <p>IT IS THE USER'S RESPONSIBILITY TO REPLACE THE DUST CAPS WITH CABLE GLANDS, ADAPTORS AND/OR BLANKING PLUGS WHICH ARE SUITABLE FOR THE ENVIRONMENT INTO WHICH THIS PRODUCT WILL BE INSTALLED. THIS INCLUDES ENSURING COMPLIANCE WITH HAZARDOUS LOCATION REQUIREMENTS AND REQUIREMENTS OF OTHER GOVERNING AUTHORITIES AS APPLICABLE.</p>
---------------	---

Install the Transmitters in accordance with national and local code requirements. Conduit entry plugs and adapters must be suitable for the environment, and be certified for the hazardous location when required and acceptable to the authority having jurisdiction for the plant.

Table 3-20: Conduit entry plug installation

Step	Action
1	Remove the protective plastic cap from the threaded conduit entry.
2	To ensure the environmental ingress protection rating on tapered (NPT), a non-hardening thread sealant may be used.
3	Thread the appropriate size conduit plug (M20 or ½" NPT) into the conduit entry opening. Do not install conduit entry plugs in conduit entry openings if adapters or reducers will be used.
4	Using a 10 mm hex wrench, tighten plugs to 32 Nm (24 lb-ft).

Table 3-21: Conduit adapter installation

Step	Action
1	Remove the protective plastic cap from the threaded conduit entry.
2	To ensure the environmental ingress rating on tapered threads (NPT), a non-hardening thread sealant may be used.
3	Thread the appropriate size adapter (M20 or ½ NPT) into the conduit entry opening
4	Using a 1-1/4" wrench tighten adapters to torque 32 Nm (24 lb-ft).

3.2.14 Flange pressure ratings

ANSI:

316/316L Flanges according to ANSI B16.5

SLG720: Max. 200°C/40 bar (392°F/580 psig).

SLG726: Up to Class 1500.

C276 > 316L Flanges according to ANSI B16.5

SLG720: Max. 200°C/40 bar (392°F/580 psig)

EN:

316/316L Flanges according to EN 1092-1, material group 14E0.

SLG720: Max. 200°C/40 bar (392°F/580 psig).

SLG726: Up to PN250.

C276>316L Flanges according to EN 1092-1, material group 14E0.

SLG720: Max. 200°C/40 bar (392°F/580 psig).

Fisher and Masoneilan:

316/316L Flanges according to ANSI B16.5.

SLG720: Max. 200°C/40 bar (392°F/580 psig).

SLG726: Up to Class 600.

3.2.15 Material Exposed to Tank Atmosphere

SLG720	316L (UNS 31603), PTFE, and O-ring materials (FKM, FFKM, EPDM, or NBR).
SLG720	C-276 Option (HASTELLOY): Alloy C-276 (UNS N10276), PTFE, and O-ring materials (FKM, FFKM, EPDM, or NBR).
SLG726	High Temperature Region: 316L (UNS 31603), Ceramic (Al ₂ O ₃), BOROFLOAT® 33 Glass. Low Temperature Region: PEEK GF30, Gold over Nickel plate on Brass Alloy 360, Gold over Nickel plate on Beryllium Copper Alloy 172 HT, and seal materials (Gold Plated Alloy 718 or Silver with Gold underlay plated 17-4PH).

3.3 Electrical Installation

3.3.1 Wiring a transmitter

The transmitter is designed to operate in a two-wire power/current loop with loop resistance and power supply voltage within the operating range shown in Figure 3-44.

3.3.2 HART / 4-20mA Voltage Operating Ranges

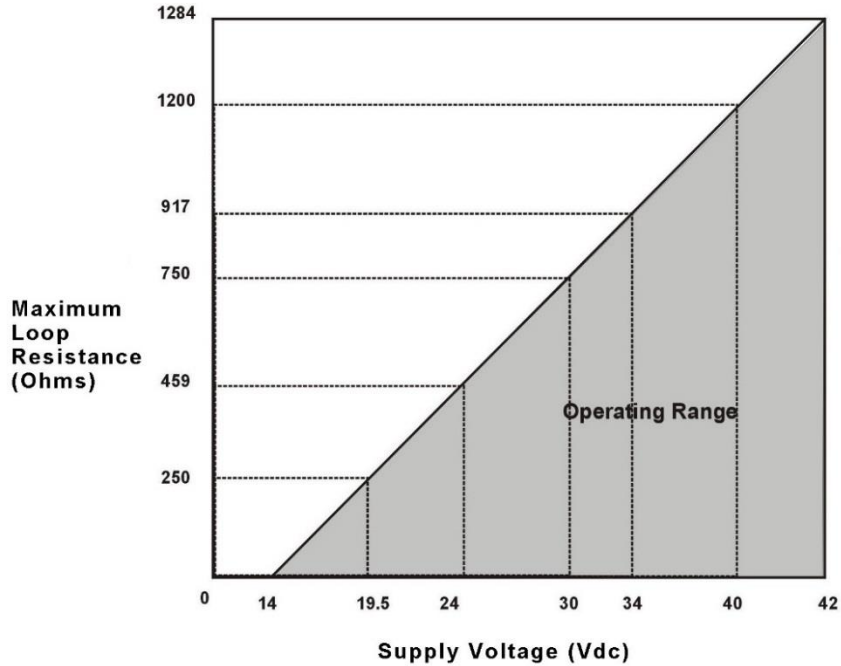

Note: A minimum of 250ohms of loop resistance is required to support communications.

Loop resistance = Barrier resistance + Wire resistance + Receiver resistance

Supply Voltage (Vdc)	Max. Loop Resistance (Ohms)
14	0
19.5	250
24	459
30	750
34	917
40	1200
42	1284

Figure 3-44: Transmitter operating ranges

Consideration is required when selecting intrinsic safety barriers to ensure that they will supply at least minimum Transmitter voltage ($V_{XMTR MIN}$), including the required 250 Ω of resistance (typically within the barriers) needed for digital communications.

Transmitter loop parameters are as follows:

$R_{LOOP MAX}$ = maximum loop resistance (including barriers and wiring) that will allow proper Transmitter operation and is calculated as

$$R_{LOOP MAX} = (V_{SUPPLY MIN} - V_{XMTR MIN}) \div 21.8 \text{ mA.}$$



Where:

$$V_{XMTR MIN} = 14V$$

If the total loop resistance is too high considering the HART load resistance and intrinsic safety barrier, consider the following options:

1. Do not add an additional HART load resistance if it is not required. Intrinsic safety barriers will typically have 250 Ω or more, allowing handheld devices to communicate in the field. Additional HART load resistance is typically only required for HART connections in the safe area.
2. Using HART multi-drop mode will effectively allow a higher loop resistance. See section 1.4.1 for details. This option is not possible if a 4-20 mA output signal is required.
3. Shunt the HART load resistor in the safe area with a large inductor so that the HART load impedance remains high at HART signal frequencies, but much lower at DC. This solution, while it does work, may be physically inconvenient. For example, a 0.5 Henry 30 Ω choke in parallel with a 250 Ω HART resistor will serve this purpose.
4. Use an intrinsic safety isolator instead of a shunt diode barrier. These devices will provide more voltage to the transmitter since the HART load resistance in the safe area is isolated from the transmitter loop. These devices are sometimes called smart transmitter barriers or supplies, or repeater power supplies. Ensure that the isolator will pass HART signal frequencies in both directions.

For wiring transmitters in hazardous area locations, also refer to Section 9 for more information.

	<p>Loop wiring is connected to the Transmitter by simply attaching the positive (+) and negative (-) loop wires to the first two terminals on the left, marked with LOOP+ and LOOP- on the transmitter body in the Electronic Housing as shown in Figure 3-45. The third terminal to the right is a TEST terminal and is only used for loop current diagnostics / measurements.</p>
	<p>TIP: A current measurement device with low internal resistance (<10ohms) can be connected between the TEST terminal “+” and the TEST terminal “-“ of the Transmitter Terminal Block to acquire a rough readout of the loop current.</p>



Loop current wiring should never be connected to the TEST “+” terminal. This can damage the Transmitter.

Additionally, never connect the current measurement device between the Loop “+” terminal and the TEST “+” terminal. This also will damage the Transmitter.

3.3.3 Terminal Connections

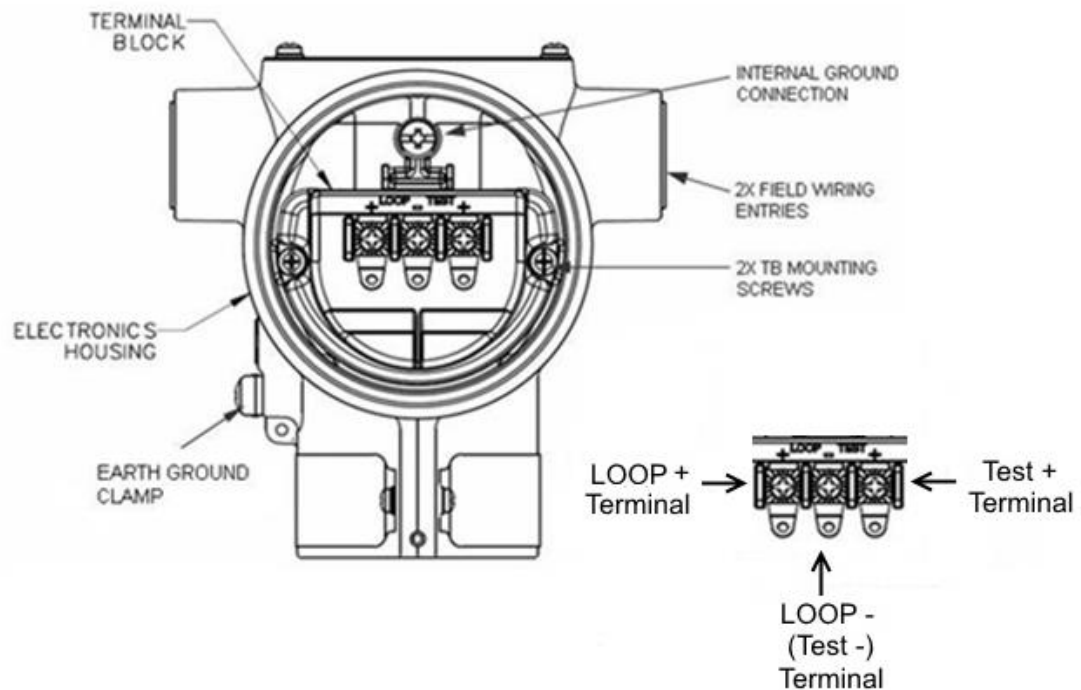

Figure 3-45: HART 3-Screw Terminal Board and Grounding Screw



A FOUNDATION Fieldbus terminal block has a 2-screw terminal board, The Test+ terminal is not present.

As shown in [Figure 3-45](#), each Transmitter has an internal and external terminal to connect it to earth ground. Grounding the transmitter is recommended for safety, to minimize the possible effects of noise, and affords protection against lightning and static discharge. A lightning-protection terminal block can be configured or ordered and installed in place of a non-lightning terminal block for Transmitters that will be installed in areas that are susceptible to lightning strikes.

Note: The lightning-protection terminal block is red, the regular terminal blocks are black.



Wiring must comply with local codes, regulations and ordinances.

Grounding may be required to meet various approval body certification, for example CE conformity. Refer to the Appendix of this document for details.

3.3.4 FOUNDATION Fieldbus

FOUNDATION Fieldbus transmitters require a terminal voltage of 9.0V to 32.0V. See page 170 for intrinsically safe and FISCO parameters.

3.3.5 Wiring Procedure

1. Ensure the loop power supply is off.
2. See Figure 3-45 for parts locations. Loosen the end cap lock using a 1.5mm Allen wrench.
3. Remove the end cap cover from the terminal block end of the Electronics Housing.
4. Feed loop power leads through one end of the conduit entrances on either side of the Electronics Housing. The Transmitter accepts up to 16AWG wire.
5. Plug the unused conduit entrance with a conduit plug appropriate for the environment.
6. Connect the positive loop and negative loop power terminals. The Transmitter is polarity insensitive.
7. Replace the end cap, and secure it in place.

3.3.6 Lightning Protection

If your Transmitter includes the optional lightning protection, connect a wire from the Earth Ground Clamp (see Figure 3-45) to Earth Ground as short as possible to make the protection effective. Use a size 8AWG or (8.37mm²) bare or green covered wire for this connection.

3.3.7 Supply Voltage Limiting Requirements

If your Transmitter complies with the ATEX 4 directive for self-declared approval per 94/9EC or 2014/34/EU, the power supply must include a voltage-limiting device. Voltage must be limited such that it does not exceed 42V DC. Consult the process design system documentation for specifics.

3.3.8 Process Sealing

The SLG 700 SmartLine Guided Wave Radar Level Transmitter is available as FM and CSA-certified as a Dual Seal device in accordance with ANSI/ISA-12.27.01-2003, “Requirements for Process Sealing between Electrical Systems and Flammable, or Combustible Process Fluids”.

3.3.9 Explosion-Proof Conduit Seal



When installed as explosion-proof or flame-proof in a hazardous location, keep covers tight while the transmitter is energized. Disconnect power to the transmitter in the non-hazardous area prior to removing end caps for service.

When installed as non-incendive or non-sparking equipment in a hazardous location, disconnect power to the transmitter in the non-hazardous area, or determine that the location is non-hazardous before disconnecting or connecting the transmitter wires.

Transmitters installed as explosion proof in Class I, Division 1, Group A Hazardous (classified) locations in accordance with ANSI/NFPA 70, the US National Electrical Code, with ½” conduit do not require an explosion-proof seal for installation. If ¾” conduit is used, a LISTED explosion proof seal is to be installed in the conduit, within 18” (457.2mm) of the transmitter.

4 Operating the Transmitter

4.1 User interface options

Described below are the available user interfaces. Of these interfaces only the transmitter's displays and buttons are described in this manual. The other interfaces have separate manuals: see the *SLG 700 HART Option Manual*, #34-SL-25-06 or *SLG 700 FOUNDATION Fieldbus Manual*, #34-SL-25-07.

While the transmitter will come preconfigured for a specific application (if ordered as such) it can also be reconfigured. Whichever interface is selected, the parameters available from each are similar and arranged in similar ways. Some parameters will only pertain to the interface being used, such as screen display parameters; some will only pertain to the communications protocol being used, such as PV selection with HART.

4.1.1 Transmitter advanced displays with buttons

For simple operations, the advanced display and buttons interface is preferable. For more involved operations (or in instances where the display is difficult to reach) or configuration use one of the following interfaces.

4.1.2 DTM or DD – HART and FF

There are two ways an external user interface can be connected to a Honeywell transmitter:

- Device Description (DD) files
- Device Terminal Manager (DTM) files (collection of *.dlls)

Each of these mechanisms requires an external container for hosting purposes as neither can function individually.

The DD files host container is frequently an application running on a hand-held device, such as the Honeywell Field Device Configurator (FDC) running on the Honeywell MC Toolkit 404 or the Emerson 475. The host container can also be a PC-based application, such as the ProComSol DevCom2000 application. Or the Honeywell FDM server which also has an Enhanced Device Description Language (EDDL) interpreter.

The DTM files host container can be any Field Device Technology (FDT) 1.2.1-compliant frame application such as PACTware, FieldCare, the Honeywell FDM Server as an FDT-compliant host and so forth.

The type of external user interface, either DD or DTM is independent of the electrical interface to the transmitter, HART or FF. Honeywell supplies user interfaces for both HART and FF.

Refer to applicable HART or Fieldbus manual for more information.

Honeywell provides DD and DTM files for the SLG 700 transmitters. The files may be downloaded from Honeywell's website:

<https://www.honeywellprocess.com/en-US/explore/products/instrumentation/process-level-sensors/Pages/smartline-level-transmitter.aspx>

Click the **Software tab**.

4.2 Three-Button Operation

The SLG 700 optional three-button interface provides a user interface and operation capability without exposing the transmitter electronics. [Figure 4-1](#) shows the location of the three-button option and the labels for each button.

The buttons are accessible by loosening the rightmost screw and rotating the covering nameplate.

4.2.1 Three-button operation without display

When there is no Display installed, the buttons can be used to perform a Zero or Span adjustment of the Transmitter. Caution should be taken to ensure these adjustments are only made when the correct level is present for the setting.

4.2.1.1 Zero Adjustment

This adjustment is the same as performing a Set LRV using the Display.

1. Connect a current meter or voltmeter to monitor the PV output of the Transmitter (optional, applicable to HART Transmitters only).
2. Set the level to the desired LRV position.
3. Press the Down (↓) and Zero (↑) buttons together to set the Zero.
4. Verify that the output is now 4 mA (optional, applicable to HART Transmitters only).

4.2.1.2 Span Adjustment

This adjustment is the same as performing a Set URV using the Display.

1. Connect a current meter or voltmeter to monitor the PV output of the Transmitter (optional, applicable to HART Transmitters only).
2. Set the level to the desired URV position.
3. Press the Down (↓) and Span (↵) buttons together to set the span.
4. Verify that the output is now 20 mA (optional, applicable to HART Transmitters only).

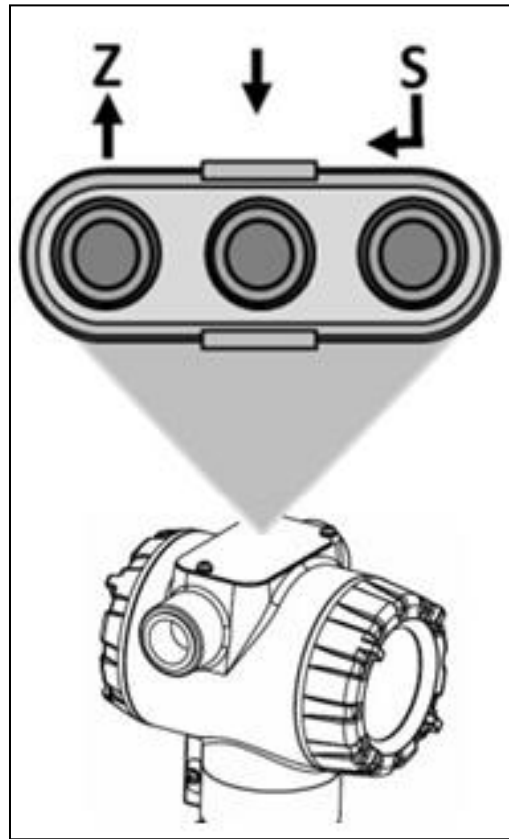

Figure 4-1: Three-Button Option

Table 4-1: Three-Button Option Functions

Physical Button	Advanced Display	Action
Left ↑	Increment Move cursor Up	Scroll to previous menu item in an active list. Scroll through alphanumeric list to desired character (ex. for entering Tag names or numeric values)
Center ↓	Decrement Move cursor Down	Scroll to next menu item in an active list. Scroll through alphanumeric list to desired character (ex. for entering Tag names or numeric values)
Right ↵	Enter	Call up the Main Menu. Call up a lower-level menu. Select an item for data entry. Confirm a data entry operation Activate the service associated with a selected menu item.

4.2.2 Menu Navigation

When on a lower level menu, return to the menu above by selecting <Return>. Alternately, the (up) and (down) buttons can be pressed simultaneously to return to the menu above. When on the highest level menu, or when using the basic display menu, pressing the (up) and (down) buttons simultaneously will exit the menu and return to the PV display.

Use the ↑ and ↓ buttons to scroll through the list of menu items. Use the ↵ button to select an item for data entry or activation. When a selection or activation is performed, this calls up a pop-up window (Advanced Display) to allow editing. No action is taken against a menu item until the ↵ button is pressed.

If you press ↵ button to begin data entry, you must press another button within 10 seconds or the data entry will time out and the original value of the parameter will be preserved.

If no button presses occur within 60 seconds, menu access will time out and the transmitter will exit the menu and return to the PV display.

4.2.3 Data Entry

Data entry is performed from left to right. Select a character / digit by pressing ↑ or ↓ buttons, and then press ↵ to advance to the next character position to the right. Select the cross-hatch character  to terminate the entry or if the final character is already a space character, just press ↵ again.

All numeric entries are clamped at the low or high limit if needed. To show the low and high limit for a parameter, put the cursor over the left-most digit, select either the ▲ or ▼ character and press ↵ button.

Table 4-2: Three-Button Data Entry

Screen Symbol	Numeric data entry	Text entry
▲	Display the high limit for this parameter. This symbol only appears in the left-most position of the data entry field.	Not Available
▼	Display the low limit for this parameter. This symbol only appears in the left-most position of the data entry field.	Not Available
☐	Terminate the numeric entry	Terminate the text entry
0 thru 9, Minus, Decimal	These characters are used to enter numeric values. The minus sign only appears in the left-most digit.	These characters can be used to create custom tags and unit labels
A thru Z, 0 thru 9 special symbols	Not Available	These characters can be used to create custom tags and unit labels

4.2.4 Editing a Numeric Value

Editing a numeric value is a digit-by-digit process, starting with the left-most digit.

1. Press \leftarrow to begin.
2. The Advanced Display will show the current value of the item in a pop-up window in the middle of the screen
3. Press the \uparrow or \downarrow buttons to select the desired digit and then press \leftarrow to advance to the next digit to the right.
4. After the last digit has been entered, press \leftarrow to write the new value to the transmitter.

4.2.5 Selecting a new setting from a list of choices

To select a new setting for parameters that presents a list of choices (for example, Screen Format or Display Units.):

1. Press \leftarrow to begin.
2. The Advanced Display shows the current setting of the item in a pop-up window.
3. Press \uparrow or \downarrow to scroll through the list of choices.
4. Press \leftarrow to make your selection. The new selection will be stored in the transmitter and will be displayed on the lower line, right justified.

4.3 The Advanced Display Menu

[Table 4-3](#) shows the top 3 levels of the Advanced Display menus. At each level is a <Return> that lets you return to the previous level.

Table 4-3: Advanced Display Main Menu Structure

Level 1	Level 2	Level 3
<Exit>	N/A	N/A
Display Config	LCD Contrast Common Setup Screen 1-8	For details see Table 4-5: Display Config sub-menu page 103.
Basic Config	General Process Measurement Dynam Variables 4-20 mA Outputs Set LRV Set URV Dev Install Date	For details see Table 4-6: Basic Configuration sub-menu page 105.
Advance Config	Mounting Backgrnd Capture Probe Volume Reflectn Model DAC Trim Loop Test HART Params	For details see Table 4-7: Advanced Config sub-menu page 109. Advanced Display supports the configuration of up to 8 different screens.
Monitor	Critical Diag NonCritical Diag Device Vars Display Info Comm Info Sensor Info Echo Stem Plot Model Number Licensed Options	For details see Table 4-8: Monitor sub-menu page 114.

4.3.1 Correlation Model Recalculation

Information on what triggers a correlation model recalculation is summarized in the table below.

Table 4-4: Correlation Model Recalculation

Parameter recalculated	Parameters that will trigger recalculation / reset required
Surface Model Gain	Vapor DC, Upper DC, Lower DC, Application Type, Probe Type, Transmitter Model, Mounting Location, Sensor Connection Type, Mounting Diameter
Interface Model Gain	Upper DC, Lower DC, Application Type, Probe Type, Transmitter Model, Mounting Location, Sensor Connection Type, Mounting Diameter
End of Probe Model Gain, Width, Attenuation	Probe Type, Probe End Type, Centering Disc Diameter, Transmitter Model, Mounting Location, Sensor Connection Type, Mounting Diameter
Process Connector Model Gain, Width, Attenuation	Transmitter Model, Sensor Connection Type, Probe Type
Propagation Factor	Transmitter Model, Probe Type
Vapor Attenuation	Transmitter Model, Probe Type
Minimum BDH/BDL	Vapor DC, Upper DC, Lower DC, Probe Type, Application Type
BDH/BDL	Vapor DC, Upper DC, Lower DC, Probe Type, Application Type

Table 4-5: Display Config sub-menu

This table describes the Advanced Display menu's "Display Config" sub-menu.

<Return> Return to the Level 1 menu				
Level 2	Level 3		Description	Action
LCD Contrast	<Return>			
	Set Contrast	# #	Adjust the LCD contrast level. Range from 0 to 9. Default: 5 Select 0 for minimum contrast and 9 for maximum contrast.	Press ↓ to enter menu selection ↑ and ↓ to select number. ↓ to enter and shift to next digit
Common Setup	<Return>			
	Set Password (HART only)	####	The user can set a 4-digit numeric (0-9) password Default: 0000. If password is set to a value other than 0000, display would prompt for valid password if user tries to change device configuration. User needs to provide password only one time when entering menu mode.	Press ↓ to enter menu selection ↑ and ↓ to select from list. ↓ to enter
	Language (FF read only)	English French German Italian Spanish Russian Turkish	Select the language for the Display. Default: English	
	Rotation Time	# #	Time duration, in seconds, that each configured screen is shown before moving to the next screen. Range: 3 to 30 seconds Default: 10 seconds	Press ↓ to enter menu selection ↑ and ↓ to select number. ↓ to enter and shift to next digit
	Screen Rotate	Yes No	Activate rotation between up to 8 screens. If user selects 'Yes', screens would rotate automatically based on configured Rotation Time.	Press ↓ to enter menu selection ↑ and ↓ to select number. ↓ to enter

Display Config” sub-menu, continued ..

Screens 1-8	<Return>			
	Screen Format (FF read only)	None PV PV & Bar Graph PV & Trend	Select the Screen format from the list.	Press \downarrow to enter menu selection \uparrow and \downarrow to select from list
	Trend Hours (FF read only)	##	Select the amount of historic data visible on the Trend screen. Range: 1 to 999 hours. Applies to the “PV & Trend” format only	
	PV Selection (FF read only)	Product Level % Prod Level Dist To Prod Prod Lvl Rate Product Volume Vapor Thick % Vapor Thick Vapor Volume Intf Level % Intf Level Dist To Intf Intf Lvl Rate Upr Prod Thick Lower Prod Vol Upper Prod Vol Loop Output Percent Output	Select the Process Variable (PV) to be shown on screen. Choices based on Measure Product and Volume Calc Type.	
	Display Units (FF read only)	Level, Interface & Distance: ft, in, m, cm, mm Volume: ft ³ , in ³ , US gal, Imp gal, bbl oil, bbl liq, yd ³ , m ³ , liters Level Rate: ft/s, ft/m, m/s, in/min, m/h Internal temp: °F, °C	Select the Display Units for the selected PV.	Press \downarrow to enter menu selection \uparrow and \downarrow to select from list.
	Custom Units (FF read only)	□□□□□□□□□□	Enter Custom Units using any alphanumeric value up to 14 characters long.	Read only
	Decimals (FF read only)	None X.X X.XX X.XXX	Select the decimal resolution for the PV.	Press \downarrow to enter menu selection \uparrow and \downarrow to select from list. \downarrow to enter

	Disp High Limit (FF read only)	#####	Enter the upper limit shown on the Bar Graph or Trend screen.	Press ↵ to enter menu selection ↑ and ↓ to select number.
	Disp Low Limit (FF read only)	#####	Enter the lower limit shown on the Bar Graph or Trend screen	↵ to enter and shift to next digit
	Custom Tag (FF read only)	□□□□□□□□□□	Enter Custom Tag using any alphanumeric value up to 14 characters long.	Press ↵ to enter menu selection ↑ and ↓ to select Alphanumeric ↵ to enter and shift to next char.

Table 4-6: Basic Configuration sub-menu

<Return> Return to the Level 1 menu				
Level 2	Level 3		Description	Action
	<Return>			
General	Short Tag (HART only)	□□□□□□□□	Enter Tag ID name up to 8 characters long. □ = any Alphanumeric value	Press ↵ to enter menu selection, ↑ and ↓ to select number, ↵ to enter and shift to next digit
	Length Unit	m cm mm in ft	Select the length unit for all level related parameters	Press ↵ to enter menu selection, ↑ and ↓ to select from list, ↵ to enter
	Temp Unit	°C °F	Select the Temperature unit for all Temperature-related parameters	
	Velocity Unit	ft/s m/s in/min m/h ft/min in/s	Select the Velocity unit for all Velocity-related parameters	
	Volume Unit	L ft ³ in ³ US gal imp gal bbl oil bbl liq yd ³ m ³	Select the Volume unit for all Volume-related parameters	

Process	<Return>				
	Measured Prod	Single Liquid 2 Liq Flooded 2 Liq NonFlood Saturated Steam SingleLiqLowDC	Select the Measured Product from the List	Press ↓ to enter menu selection, ↑ and ↓ to select from list, ↵ to enter	
	Vapor DC	###.###	Applicable for single and two liquids, non-flooded only. If its value greater than UP/LP DC Warning message will be displayed		
	Product DC		Applicable only for solid and single liquid measured products. If its value is less than Vapor DC, a warning message will be displayed		
	Upper Prod DC	###.###	Applicable only for two liquid measured products. If its value is less than Vapor DC or greater than LP DC a warning message will be displayed	Press ↓ to enter menu selection, ↑ and ↓ to select from list, ↵ to enter	
	Lower Prod DC		Applicable only for two liquid measured products. If LP DC - UP DC <10 a Warning message will be displayed		
	Vapor Atten	###.###	Applicable for single and two liquids, non-flooded only. Attenuation of vapor.		
	Product Atten	###.###	Attenuation of product, single liquids only		
	Lower Prod Atten	###.###	Attenuation of lower product, two liquids only		
	Upper Prod Atten	###.###	Attenuation of upper product, two liquids only		
Max Fill Rate	###.###	Maximum rate of filling or emptying.			
Measurement	<Return>				
	Sensor Height	###.###	Range 0 to 100m		Press ↓ to enter menu selection, ↑ and ↓ to select from list, ↵ to enter
	Max Product Level		Range -100 to 100m		
	Level Offset	###.###	Time in seconds until a PV Bad fault occurs after the echo is no longer detected.		
Echo Lost Time					

Dynm Variables (HART only)	<Return>			
	Measured Prod	Single Liquid 2 Liq Flooded 2 Liq NonFlood Saturated Steam SingleLiqLowDC	Read-Only	
	PV	Product Level % Prod Level Dist To Prod Prod Lvl Rate Product Volume Vapor Thick % Vapor Thick Vapor Volume Intf Level % Intf Level Dist To Intf Intf Lvl Rate Upr Prod Thick Lower Prod Vol Upper Prod Vol	PV = Primary Variable SV = Secondary Variable TV = Tertiary Variable QV = Quaternary Variable	Press ↵ to enter menu selection, ↑ and ↓ to select from list, ↵ to enter
	SV			
	TV			
QV	Configure the dynamic variables for monitoring on a host such as DTM or handheld device.			
<Return>				
4-20 mA Output (HART only)	LRV	#####.###		Press ↵ to enter menu selection, ↑ and ↓ to select from list, ↵ to enter and shift to next digit
	URV			
	Damping		##.#	
	NAMUR Output	Disabled Enabled	Disabled: Sets loop output and burnout levels to Honeywell levels. Enabled: Sets loop output and burnout levels to the NAMUR levels	
	Loop Curr Mode		Disabled: Required for multi-drop HART communications.	
	Latching Mode	Latching Non-Latching	Latching Mode: This parameter allows selection of transmitter critical error behavior. Latching: The transmitter will remain in a critical error state until a user performs a hardware / software reset. Non-Latching: The transmitter exits critical error state automatically when causes of the critical error have been resolved.	
	BDH/BDL Loop	Hi Saturation Low Saturation Last Good Val Default	Loop output when level is in a high or low blocking distance zone.	
Set LRV (HART only)	<Return>			
	Set LRV	ATTENTION: Executing this service will set the Lower Range Value (LRV) equal to the input GWR Level.		Press ↵ to enter menu selection, ↵ to execute
	Set URV	ATTENTION: Executing this service will set the Upper Range Value (URV) equal to the input Guided Wave Radar Level.		

Install Date (HART only)	<Return>			
	Year	####	Enter the current year. Year will only be visible if no Install Date has been written to the transmitter.	Press ↵ to enter menu selection, ↑ and ↓ to select number, ↵ to enter and shift to next digit
	Month	January to December	Select the current month. Month will only be visible if no Install Date has been written to the transmitter.	Press ↵ to enter menu selection, ↑ and ↓ to select month, ↵ to enter
	Day	##	Enter the numeric value of the current date. Day will only be visible if no Install Date has been written to the transmitter.	Press ↵ to enter menu selection, ↑ and ↓ to select number, ↵ to enter and shift to next digit
	Install Date	dd-mmm-yyyy	This displays a preview of the user configured date. If no Install Date has been written to the transmitter. 1 Jan 1972 is displayed.	ATTENTION: the Install Date can only be written once throughout the life of the transmitter. You cannot delete or overwrite the Install Date when written to the transmitter.
	Write Date		Configures the date as provided by user.	

Table 4-7: Advanced Config sub-menu

This table describes the Advanced Display menu’s “Advance Config” sub-menu.

Advanced configuration is described in detail in the *SLG 700 HART Option manual, #34-SL-25-06*.

<Return> Return to the Level 1 menu				
Level 2	Level 3		Description	Action
	<Return>			
Mounting Note: Loop must be removed from Automatic Control	Transmtr Model (R)	SLG720 SLG726	Standard High Temperature & High Pressure	Read only
	Sensor Conn Type (R)	Direct Remote	Type of connection of sensor housing to process connection.	Press ↓ to enter menu selection ↑ and ↓ to select number. ↓ to enter and shift to next digit
	Proc Conn Type (R)	Threaded Flanged	Type of Process connector	Read only
	Mounting Loc	Tank Bracket Nozzle Bypass Stillwell	Location and structure of transmitter mounting.	Press ↓ to enter menu selection ↑ and ↓ to select number. ↓ to enter and shift to next digit
	Mounting Angle (Visible for Tank, Bracket or Nozzle mounting location only)	0 to 90 degrees	Angle of transmitter.	
	Nozzle Height (Nozzle Mounting Loc only)	##.###	Mounting structure height.	
	Nozzle Dia (Nozzle Mounting Loc only)	##.###	Diameter of the nozzle.	
	Bypass Dia (Bypass Mounting Loc only)	##.###	Diameter of the bypass.	
	Stillwell Dia (Stillwell Mounting Loc only)	##.###	Diameter of the Stillwell.	
	Backgrnd Type	Factory Field Obstacle	Field background type to use for factory-preset noise, captured noise or captured obstacle cancellation.	
	Dynm Bkgd Updt (Field and Obstacle Backgrnd Type only)	Enabled Disabled	Captured background is updated every few hours and for each 10°C (18°F) change in product temperature.	
	Full Tank Det	Enabled Disabled	Detection of product at top of flange.	

Backgrnd Capture (Measured Prod not Saturated Steam)	Backgrnd Type	Field Obstacle	Background type to capture.	Press ↵ to select action
	Use Level (Obstacle Backgrnd Type only)	Yes No	Use level instead of distance to surface for Obstacle capture length entered at time of capture.	
	Start Capture (capture process is inactive)		Begins a field background capture process, with progress indicated by bar graph on line immediately above. For Obstacle captures, an entry of the capture length is required.	
	Cancel Capture (capture process is active)		Cancels the currently active field background capture process.	
<Return>				
Probe Note: Loop must be removed from Automatic Control.	Probe Type	Custom Rod Wire Coax Multi-twist Wire PTFE Rod PTFE Wire	Type of probe.	Press ↓ to enter menu selection ↑ and ↓ to select number. ↵ to enter and shift to next digit
	Probe Length	##.###	Length of the probe in the tank, in Length units.	
	Probe End Type	None Clamp Weight Loop	Type of probe end.	
	CenterDiskType	None 316 SS PTFE C276 Ni Alloy	Type of centering disk	
	CenterDisk Dia (If Center Disk Type is not None)	2 inch to 8 inch	Diameter of centering disk	
	PropagtnFactor	#.#####	Probe wave propagation factor	
	Block Dist Hi	#.###	Configures region near the flange where measurements are not possible and inaccurate. Value entered is in Length units.	
	Block Dist Low	#.###	Configures region near the Probe end where measurements are not possible and inaccurate. Value entered is in Length units.	
	SteamRefPrbTyp (Saturated Steam Measured Prod only)	None 30 cm 50 cm	Type of steam reference probe.	
	Steam Ref Len (Saturated Steam Measured Prod only)	##.###	Length of Steam Reference Probe, in Length units.	

Probe Length Cal (SingleLiqLo wDC Measured Prod only)	<Return>			
	Start Cal (calibration process is inactive)		Begins a probe length calibration, with progress indicated by bar graph on line immediately above.	Press ↵ to select action
	Stop Cal (calibration process is inactive)		Cancels the currently active probe length calibration process.	
Steam Ref Cal (Saturated Steam Measured Prod only)	<Return>			
	Start Cal (calibration process is inactive)		Begins a steam reference calibration, with progress indicated by bar graph on line immediately above.	Press ↵ to select action
	Stop Cal (calibration process is inactive)		Cancels the currently active steam reference calibration process.	

Volume	<Return>			
	Vol Calc Type	None Tank Shape Strapping Table	Volume calculation type	Press ↓ to enter menu selection. ↑ and ↓ to select from list. ↵ to enter.
	Tank Shape	Sphere Cube Horz Bullet Vert Bullet Vert Cylinder Horz Cylinder Rectangle	Visible only if Vol Calc Type is Tank Shape.	
	Tank Diameter	###.###	Visible for Sphere, Bullet and Cylinder Tank Shapes only. Value entered is in Length units.	Press ↓ to enter menu selection. ↑ and ↓ to select number. ↵ to enter and shift to next digit
	Tank Length	###.###	Visible for Cube, Rectangle, Horz Bullet and Horz Cylinder Tank Shapes only. Value entered is in Length units.	
	Tank Width	###.###	Visible for Rectangle Tank Shape only. Value entered is in Length units.	
	Tank Height	###.###	Visible for Vert Bullet and Vert Cylinder Tank Shapes only. Value entered is in Length units.	
	Volume Offset (Vol Calc Type is Tank Shape only)	###.###	Offset value applied to the calculated volume. Visible only if Vol Calc Type is Tank Shape.	

Reflectn Model	<Return>			
	Ampl Tracking	Enabled Disabled	Improved level tracking for difficult conditions or uncertain medium attenuation.	Press ↓ to enter menu selection. ↑ and ↓ to select from list. ↓ to enter.
	Location	Process Conn Surface Interface Probe End Saturated Steam	Reflection model location	
	Width	####	Width of model in mm.	Press ↓ to enter menu selection. ↑ and ↓ to select number. ↓ to enter and shift to next digit
	Attenuation	##.##	Attenuation of the model.	
	Gain	#####	Gain of model.	
	Obj Fin Thrshld	#. #	Objective function threshold of the model.	

DAC Trim (HART only)	<Return>		
	Trim Zero	This selection will calibrate the loop zero output to 4.000 mA. Connect a current meter to the transmitter to monitor the loop output. Note: The TEST +/- terminals should not be used to trim the transmitter. Press Enter to set the loop output to 4mA. When the prompt "Enter reading" appears, enter the value shown on the current meter (in milliamps) and press Enter again. The transmitter adjusts the DAC output to 4mA.	Press ↓ to enter menu selection. ↑ and ↓ to select number. ↓ to enter and shift to next digit
	Trim Span	This selection will calibrate the loop span output to 20.000mA Connect a current meter to the transmitter to monitor the loop output. Note: The TEST +/- terminals should not be used to trim the transmitter. Press Enter to set the loop output to 20mA. When the prompt "Enter reading" appears, enter the value shown on the current meter (in milliamps) and press Enter again. The transmitter will adjust the DAC output to 20mA.	
Note: Loop must be removed from Automatic Control	Set DAC Normal	This selection allows the loop to be returned to its Normal mode (Automatic Control) after performing the Trim operation.	Press ↓ to enter menu selection. Scroll to Set DAC Normal Press ↓ to initiate
<Return>			

Loop Test (HART only) Note: Loop must be removed from Automatic Control	Set DAC Output	This selection allows you to force the DAC output to any value between 3.8 and 20.8mA. Note: This selection will put the DAC into Fixed Output Mode.		Press ↓ to enter menu selection Scroll to Set DAC Normal Press Enter to initiate ↑ and ↓ to select number. ↓ to enter and shift to next digit	
	Set DAC Normal	This selection allows the loop to be returned to its Normal mode (Automatic Control) after performing the Trim operation.		Press ↓ to enter menu selection. Scroll to Set DAC Normal Press ↓ to initiate	
HART Params (HART only)	<Return>				
	Poll Address	##	0 (default) to 63		Press ↓ to enter menu selection. ↑ and ↓ to select number. ↓ to enter and shift to next digit
	Final Assy Num	###	Asset tracking number		
	Show Date	Yes No	If Yes selected HART Date Options will be visible and can be configurable		
	Year	# # # #	Enter the current year.		
	Month	January - December	Select the current month.		
	Day	# #	Enter the day of the month.		
	Write Date	Press Enter to write the HART Date to the transmitter.			

Table 4-8: Monitor sub-menu

This table describes the Advanced Display menu’s “Monitor” sub-menu. All items are Read-Only. Refer to troubleshooting for resolutions.

<Return> Return to the Level 1 menu			
Level 2	Level 3	Status	Description
Critical Diag	<Return>		
	Active Diags (R)	# #	
	Sensor Module (R)	OK FAULT	FAULT: There is a problem with the Sensor.
	Comm Module (R)	OK FAULT	FAULT: There is a problem with the Communications Module (HARTor FF), There are one of the following failures: RAM Failure: Restart the device. If error continues, replace the HART communication board. ROM Failure: Reflash / reload the HART firmware. If error continues, replace the HART communication board. V_{cc} Failure: If the power accumulator (PA) fault is not detected, change the HART communication board.
	Sensor Comm (R)	OK FAULT	FAULT: There is a problem with the interface between the Sensor and the Electronics Module.
	Measurement (R)	OK FAULT	FAULT: There is a problem with the PV measurement.
	Reset Required (R)	OK FAULT	FAULT: A parameter has been changed that requires a transmitter restart.
	Soft Reset		Perform transmitter restart
	Detail Diag	Yes No	Yes: All menu items to Factory Mode are available. No: The menu options end with Detail Diag.
	Sensor Int RAM (R)	OK FAULT	FAULT: Sensor Internal RAM is Bad
	Sensor Ext RAM (R)	OK FAULT	FAULT: Sensor Internal RAM is Bad
	Sensor Flash CRC (R)	OK FAULT	FAULT: Sensor Flash CRC is Bad
	Sensor Pwr Vosc (R)	OK FAULT	FAULT: The Vosc measurements are out of range, resetting the device if the problem persists, replace the Sensor Housing.
	Sensor Pwr 2.5V (R)	OK FAULT	FAULT: Sensor Power Supply 2.5V is Bad
	Sensor Pwr 3.3V (R)	OK FAULT	FAULT: Sensor Power Supply 3.3V is Bad
	Sensor Pwr Accum (R)	OK FAULT	FAULT: Power Accumulator Board is Bad
	Sensor Code Flow (R)	OK FAULT	FAULT: Sensor Execution is not working as intended
	Sensor Oscillator (R)	OK FAULT	FAULT: Sensor Oscillator Control Status is Bad
	Factory Mode (R)	Yes No	Yes: Sensor is in Factory Mode No: Sensor is in User Mode

Critical Diag	Low Power Mode (R)	Yes No	Yes: Sensor is in low power mode
	Reflectn Ref Loc (R)	OK FAULT	FAULT: Reflection reference cannot be located
	Ref Plane Offset (R)	OK FAULT	FAULT: Reference plane offset is invalid
	Unlic Intf Meas (R)	OK FAULT	FAULT: Unlicensed Interface measurement option
	Unlic Sat Steam (R)	OK FAULT	FAULT: Unlicensed Saturated Steam application option
	Unlic Low DC App (R)	OK FAULT	FAULT: Unlicensed Low DC application option
	ModelNumMismatch (R)	Yes No	Yes: Mismatch between Sensor and Comm Module Model Numbers
	Sensr DB Corrupt (R)	Yes No	Yes: The Sensor Module database is corrupt and requires reset
	Reset Sensr DB (Sensor DB corrupt only)		Perform reset of Sensor Module database to SLG720 factory defaults
	Comm DB Corrupt (R)	Yes No	Yes: The Comm Module database is corrupt and requires reset
	Reset Comm DB (Comm DB corrupt only)		Perform reset of Comm Module database to SLG720 factory defaults

<Return>			
Non-Crit Diag	Active Diags (R)	# #	Shows the number of Non-Critical Diagnostics that are currently active
	Supply Voltage (R)	OK LOW HIGH	LOW: Supply voltage is below the low specification limit HIGH: Supply voltage is above the high specification limit.
	Elec Module Temp (R)	OK OVERTEMP	OVERTEMP: Electronics temperature is outside the operating range (-40°C to +85°C).
	DAC Temp Comp (R) (HART only)	OK NO COMPENSATION	The DAC has not been compensated for temperature effects. This is a factory operation.
	Sensor Comm (R)	OK SUSPECT	SUSPECT: The interface between the Temperature Sensor Module and the Electronics Module is experiencing intermittent communication failures.
	Display Setup (R) (HART only)	OK NVM Corrupt	NVM Corrupt: The Display memory is corrupt.
	Characterized (R)	Yes No	Yes: Sensor is Characterized No: Sensor is not Characterized
	Charact. Status(R)	OK FAULT	OK: Characterization table CRC is OK FAULT: Sensor Characterization data is corrupted. When this fault occurred, Sensor Module fault of Critical Diagnostic will be set.
	PV Range (R)	OK Out Of Range	Out of Range: PV is not within the range limits
	Sensor Over Temp (R)	OK OVER TEMP	OVERTEMP: Sensor temperature is greater than 125°C.

Non-Crit (continued)	Surface Sgnl Str (R)	Good Bad	Bad: Signal Strength is bad
	Surfac Sgnl Qlty (R)	Good Bad	Bad: Signal Quality is bad
	Interfc Sgnl Str (R)	Good Bad	Applicable for Two Liquid Products Bad: Signal Strength is bad
	Interfc Sgnl Qlty (R)	Good Bad	Applicable for Two Liquid Products Bad: Signal Quality is bad
	Sensing Section (R)	OK FAULT	This is a roll-up status that is set when any of the following non-critical status conditions are present: <ul style="list-style-type: none"> • Sensor Over Temperature • Level is in upper blocking distance zone. • Level is in lower blocking distance zone. • Sensor Not Characterized • Sensor Not Calibrated
	Blk Dist Hi Zone (R) (single liquid only)	Yes	These parameters mark regions outside accurate measurement. If the level enters either of these regions then Status = Unknown.
	Blk Dist Lo Zone (R) (single liquid only)	No	
	Surface in BDH (R) (two liquids only)	Yes No	These parameters mark regions outside accurate measurement. If the surface level enters either of these regions then Status = Unknown.
	Surface in BDL (R) (two liquids only)	No	
	Interface in BDH (R) (two liquids only)	Yes No	These parameters mark regions outside accurate measurement. If the interface level enters either of these regions then Status = Unknown.
	Interface in BDL (R) (two liquids only)	No	
	Snsr Calibrated (R)	Yes No	Yes: Sensor is calibrated No: Sensor is not calibrated
	Calibration Type (R)	Standard Custom	Standard: Device is calibrated for standard points. Custom: Device is calibrated for user-defined points.
	FldBkgdNotCompat	Yes No	Yes: The Field Background is not compatible.
	Backgrnd Not Set	Yes No	Yes: The Background is not set.
	FldgBkgdLoadError	Yes No	Yes: Field Background loading error.

Device Vars	<Return>		
	Measurd Prod Lvl (R)	Non-linearized product level	HART only. If linearization is disabled then Product Level and Measurd Prod Lvl will be same.
	Surface Sgnl Str (R)	Surface Signal Strength	Signal strength depends on a function of distance and the medium. As the level and interface peaks are negative, a more negative value indicates a better signal. Signal strength improves as distance decreases. Normal range: (-500) – (-9000)
	Interfc Sgnl Str (R)	Interface Signal Strength For 2 liquid cases	
	Surface Sgnl Qlty (R)	Surface Signal Quality	Quality measurements range: 0 – 1 Less than 0.3 = Bad 0.6 -- 0.8 = Good 1 = Perfect
	Interfc Sgnl Qlty (R) (two liquids only)	Interface Signal Quality For 2 liquid cases	
	Int Elec Temp (R) (two liquids only)	Internal Electronics Temperature	Internal temperature measurement of the sensing module.
Display Info	<Return>		
	Firmware Version	#	Firmware version of display module

(R) Read-Only parameter

Comm Info	<Return>		
	Firmware Version	#	Firmware version of communications module
	Protocol (R)	HART/FF	Communications protocol of transmitter
	Universal Rev (R) (HART only)	N/A	Applicable only for HART device Revision of Hart specification
	Field Dev Rev (R) (HART only)		Applicable only for HART device. HART HCF hardware revision For DD/DTM compatibility
	Software Rev (R) (HART only)		Applicable only for Hart device Hart HCF software revision
	PV Alarm Type (R) (HART only)	HIGH LOW	Applicable only for HART device Loop current behavior during critical fault. HIGH : 21.5mA LOW : 3.5mA
	LRV (R) (FF only)	N/A	Displays the analog output will be scaled to 4mA.
URV (R) (FF only)	N/A	Displays the measuring value for which the analog output will be scaled to 20mA.	
Sensor Info	<Return>		
	Firmware Version	N/A	Firmware version of sensor module
	Model Key		Type and range of transmitter
	Device ID		Unique for each device considered as serial number

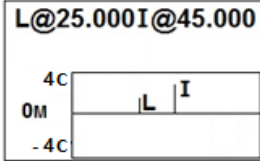
	<Return>	
	Duration	0 to 3600 sec Duration of echo stem plot
Echo Stem Plot	Show Stem Plot	<p>Displays the echo stem plot for the selected Duration. Use this display to check that the radar pulse is measuring accurately. Example: Echo stem plot for 2 liquid interface:</p>  <p>X axis: The Reference plane is at 0. Distance is in Length Unit. The above image the distance is measured in meters. Resolution: 1 pixel = 1 meter (as in the above image) Y axis: Echo amplitude is in terms of counts. The Range is -40,000 to +40,000 which is represented as -4C to +4C. Where: C = Counts S = Distance to saturated steam reference L = Distance to product I = Distance to interface E = Distance to end of probe Resolution: 1 pixel = 2000 counts Display Error Handling: “----“: In the distance field indicates the respective distance (product or interface) status is Bad. “????“: In the distance field indicates the respective distance (product or interface) status is Unknown. In the above example, the distances measured by the echo are: Product: 25 m, Interface (bottom liquid): 45 m The display updates periodically.</p>
	Model Number	<Return>
	Model Number (R) (no mismatch only)	First 16 characters of device Model Number.
	Comm Model Num (R) (mismatch only)	First 16 characters of device Model Number in Comm Module.
	Sensor Model Num (R) (no mismatch only)	First 16 characters of device Model Number in Sensor Module.
	Matching Source (mismatch only)	Source of Model Number to match. Sensor Module Comm Module
	Do Match (mismatch only)	Perform the Model Number match.
Options	<Return>	
	Interface Meas (R)	Interface Measurement option
	Saturated Steam (R)	Saturated Steam application option
	Low DC Applic (R)	Low Dielectric Constant application option
	License Key	Enter license key

(R) Read-Only parameter

4.4 Monitoring the Advanced Display

This section describes the information shown on the operator screens of the Advanced Display.

4.4.1 Advanced Displays

As shown in [Figure 4-2](#), the Advanced Display provides three formats.

Table 4-9 lists and describes the fields in each of the three Advanced Display formats. Essentially, all three formats provide the same information, but with the following differences:

- **Bar Graph:** User Configurable 126 segment Bar Graph with range settings. The Bar Graph displays the current value of the configured PV.
- **PV Trend:** User-configurable display period from 1 to 999 hours. The chart displays minimum, maximum, and average of the configured PV over the selected trend period.

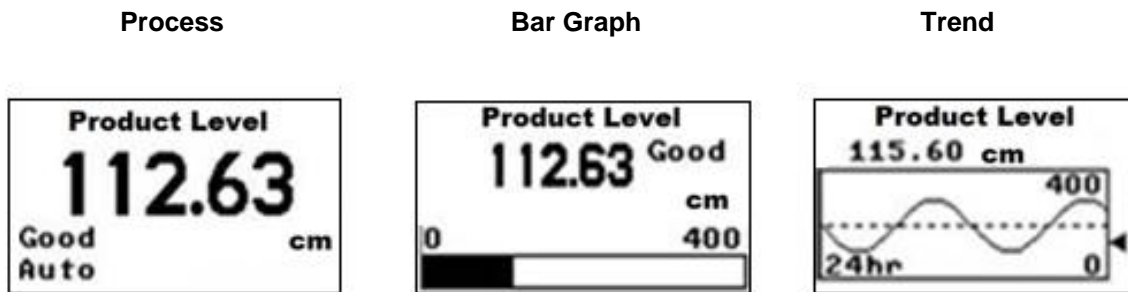

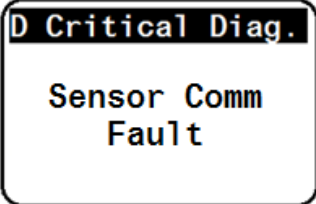

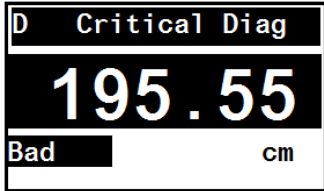

Figure 4-2: Advanced Display Formats with the Process Variable

Table 4-9: Advanced Displays with PV Format Display Indications

Display Indicator	Description
Diagnostic	<p>D Diagnostic condition present</p> <p>This indicator is displayed any time a diagnostic is present in the transmitter, either Critical or Non-Critical.</p>  <p>To determine which Non-Critical diagnostics are active, use the local buttons to call up the Non-Critical diagnostics menu. Refer to Table 4-8: Monitor sub-menu for details.</p> <p>If a Critical Diagnostic is present, the message Critical Diag will flash in the top of the screen and the appropriate Diagnostic screen will be inserted into the normal screen rotation.</p>  
Maintenance	<p>M Maintenance Mode is active</p> <p>This indicator is set by the Experion DCS. When this Mode is active, a screen with the text Available for Maintenance will be inserted into the normal screen rotation to make it easy to identify transmitters that are available for maintenance.</p> 
PV Value	<p>User Configurable. This field has 7 characters.</p> <p>Maximum allowable numeric value of 9999999 or -999999.</p> <p>If fractional decimals are configured, the fractional positions will be dropped as required.</p> <p>If the PV exceeds the values above limits, the PV is divided by 1000 and K is appended to the result, allowing a maximum value with multiplier of 999999K or -999999K</p>

Display Indicator	Description											
PV Status	<p>Good: The transmitter is operating normally</p> <p>Bad: The transmitter has detected a critical fault condition.</p> <p>The PV Status field will flash when this condition is present and the PV Value will be displayed on a black background as follows:</p>  <p>Warning: When the status field indicates a Bad status, the displayed PV value will represent the last known good value or will be set to 0 if the last known good value does not exist. A Bad status indicates that the displayed value may not represent the current process measurement and should not be used for process monitor or control.</p> <p>Unc: Uncertain (FF). The PV Value is outside of normal limits.</p> <p>Uncertain (HART): The level cannot be found within the valid measuring range. The transmitter will keep searching for a valid level and the current is set to high saturation.</p>											
PV Function Block Mode	The Function Block Mode is only displayed for FOUNDATION Fieldbus transmitters. The eight possible Modes are shown below.											
	<table border="0"> <tr> <td>OOS: Out Of Service</td> <td>RCas: Remote Cascade</td> </tr> <tr> <td>Auto: Automatic</td> <td>Rout: Remote Output</td> </tr> <tr> <td>Man: Manual</td> <td>IMan: Initialization Manual</td> </tr> <tr> <td>Cas: Cascade</td> <td>LO: Local Override</td> </tr> </table>	OOS: Out Of Service	RCas: Remote Cascade	Auto: Automatic	Rout: Remote Output	Man: Manual	IMan: Initialization Manual	Cas: Cascade	LO: Local Override			
OOS: Out Of Service	RCas: Remote Cascade											
Auto: Automatic	Rout: Remote Output											
Man: Manual	IMan: Initialization Manual											
Cas: Cascade	LO: Local Override											
Process Variable Tag	User Configurable. This field has 14 characters											
Engineering Units	User Configurable. This field has 8 characters											
	<table border="0"> <tr> <td>Guided Wave Radar Level:</td> <td>Guided Wave Radar Volume:</td> <td>Temp:</td> <td>Other:</td> </tr> <tr> <td>ft, in, m, cm, mm</td> <td>ft³, in³, US gal, Imp gal, barrels, liquid barrels, yd³, m³, liters</td> <td>°C °F</td> <td>Percent (%) milliamp (mA) Custom Text</td> </tr> <tr> <td></td> <td></td> <td></td> <td>Level Rate: ft/s, m/s, in/min, m/h</td> </tr> </table>	Guided Wave Radar Level:	Guided Wave Radar Volume:	Temp:	Other:	ft, in, m, cm, mm	ft ³ , in ³ , US gal, Imp gal, barrels, liquid barrels, yd ³ , m ³ , liters	°C °F	Percent (%) milliamp (mA) Custom Text			
Guided Wave Radar Level:	Guided Wave Radar Volume:	Temp:	Other:									
ft, in, m, cm, mm	ft ³ , in ³ , US gal, Imp gal, barrels, liquid barrels, yd ³ , m ³ , liters	°C °F	Percent (%) milliamp (mA) Custom Text									
			Level Rate: ft/s, m/s, in/min, m/h									
Bar Graph	The limits of the bar graph are user-configurable for each screen.											
Trend Graph	The limits of the trend graph are user-configurable for each screen. The amount of time visible on the Trend graph is also configurable.											

4.4.2 Button operation during monitoring

When the operator screens are active on the Advanced Display, the Increment and Decrement buttons (↑ and ↓) can be used to move to the next or previous operator screen without waiting for the rotation time to expire. Pressing the Enter button (↵) will call the Main Menu.

4.5 Changing the Failsafe Direction and Write Protect Jumpers (Including Simulation mode)

HART Transmitters are shipped preconfigured with a set failsafe direction (table V, character 4 of the model number). Upscale Failsafe means that the Transmitter output will set the HART current output to upscale failsafe (maximum output) upon detection of a critical status. You can change the direction from upscale failsafe to downscale failsafe (minimum output) by moving the top jumper located in the Electronics module.

Analog operation: Upscale failsafe drives the Transmitter output to above 21mA. Downscale failsafe drives the Transmitter output to below 3.6mA.



WARNING: If the transmitter enters a downscale burnout status, the transmitter enters a **low power mode**. The transmitter **must** be reset to recover from this condition.

When the Transmitter is in a failsafe condition, the digital process variable output should be “Not a Number (NaN)”.

4.5.1 Procedure to Establish Failsafe Operation



The failsafe direction display accessible via the Toolkit shows only the state of the jumper as it correlates to analog Transmitter operation.



The integrated circuits in the Transmitter Printed Wiring Assembly (PWA) are vulnerable to damage by stray static discharges when removed from the Electronics Housing. Minimize the possibility of static discharge damage when handling the PWA as follows:

Do not touch terminals, connectors, component leads, or circuits when handling the PWA.

When removing or installing the PWA, handle it by its edges or bracket section only. If you need to touch the PWA circuits, be sure you are grounded by staying in contact with a grounded surface or by wearing a grounded wrist strap.

When the PWA is removed from the Transmitter, put it in an electrically conductive bag, or wrap it in aluminum foil to protect it.

The following procedure outlines the steps for positioning the write protect and failsafe jumpers on the electronics module. See Figure 4-3 for the locations of the failsafe and write protect jumpers.

1. Turn OFF Transmitter power (Power removal is only required in accordance with area safety approvals and is only required in Class 1 Div 1 Explosion proof and Class 1 Div 2 environments).
2. Loosen the end cap lock, and unscrew the end cap from the electronics side of the Transmitter housing.
3. If equipped with a Display module, carefully depress the two tabs on the sides of the Display module, and pull it off.
4. If necessary, unplug the interface connector from the Communication module. Do not discard the connector.

Note: The example diagram Figure 5-2 does not display the 8-pin interface connector. The interface connector connects the Display module to the Communication module. If this is not in place the display will not receive power.

5. Set each jumper to the desired position (UP/OFF or DOWN/ON).
See Table 4-10 and Table 4-11.
6. If applicable, re-install the Display module as follows:
 - Orient the display as required.
 - Install the Interface Connector in the Display module such that it will mate with the socket for the display in the Communication module.
 - Carefully line up the display, and snap it into place. Verify that the two tabs on the sides of the display latch.

Note: Installing a Display Module into a powered transmitter may cause a temporary upset to the loop output value.

 Orient the Display for proper viewing through the end cap window. You can rotate the mounting orientation in 90° increments.

Restore transmitter power if removed.

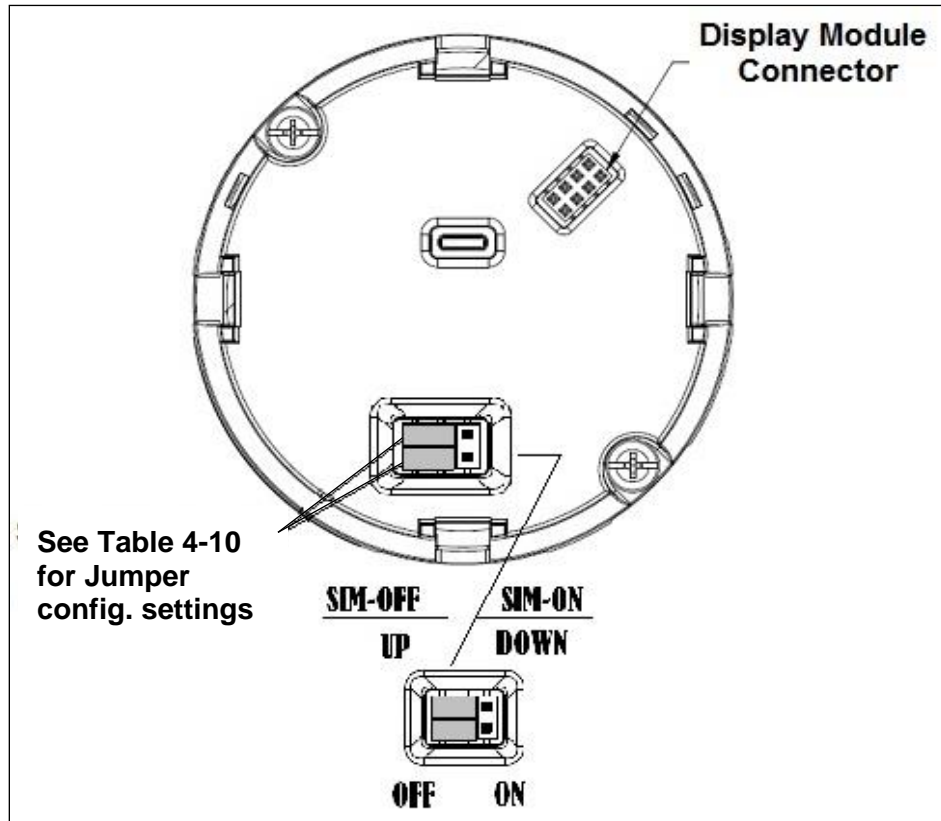

Figure 4-3: Locating the Failsafe and Write Protect Jumpers

Table 4-10: HART Failsafe and Write Protect Jumpers

Jumper Arrangements	Description
	Failsafe = UP (High) Write Protect = OFF (Not Protected)
	Failsafe = DOWN (Low) Write Protect = OFF (Not Protected)
	Failsafe = UP (High) Write Protect = ON (Protected)
	Failsafe = DOWN (Low) Write Protect = On (Protected)

Table 4-11: FOUNDATION Fieldbus Simulation and Write Protect Jumpers

Image	Description
	Fieldbus Simulation Mode = OFF Write Protect = OFF (Not Protected)
	Fieldbus Simulation Mode = OFF Write Protect = ON (Protected)
	Fieldbus SIM Mode = ON Write Protect = OFF (Not Protected)

Note: Changes to configurations and calibrations are disabled when the jumpers are set in the write-protect positions. Write-protect includes disabling password access.

5 Maintenance

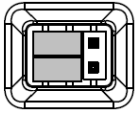
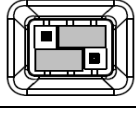
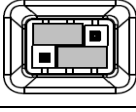
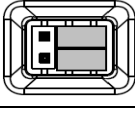
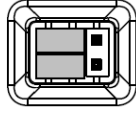
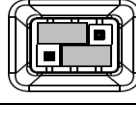
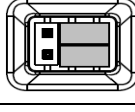
5.1 Overview

The design of the transmitter uses electromagnetic impulses guided along a metallic probe and time domain reflectometry to measure distance to measured material and convert it into level indication. Because there are no moving parts, the maintenance of the transmitter is greatly reduced in comparison with historic level measurement devices.

5.2 Preventive Maintenance Practices and Schedules

If the transmitter is installed in contact with a sticky or viscous medium, a periodic cleaning may be required. The frequency of cleaning should be adjusted based on application needs and visual inspection.

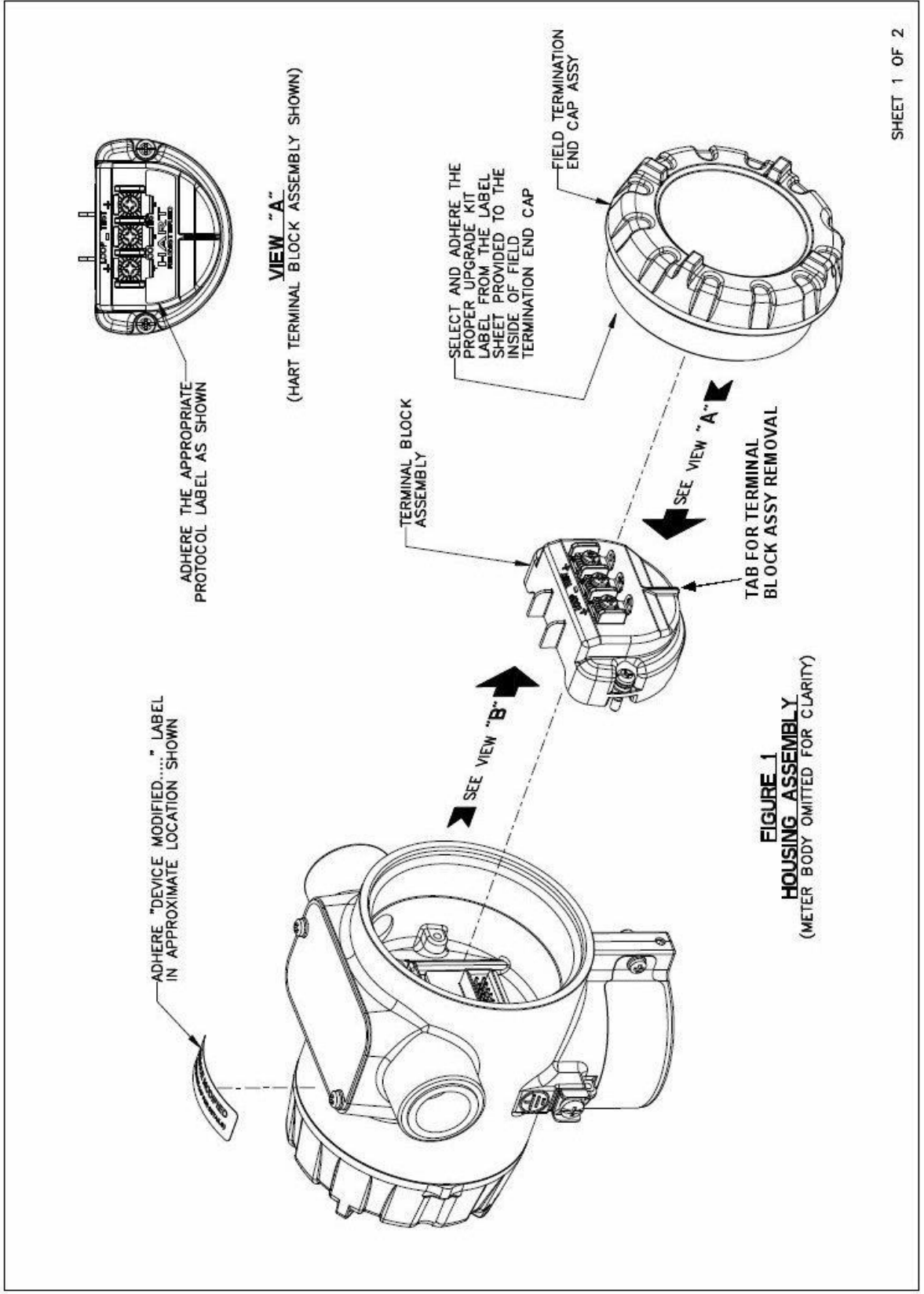

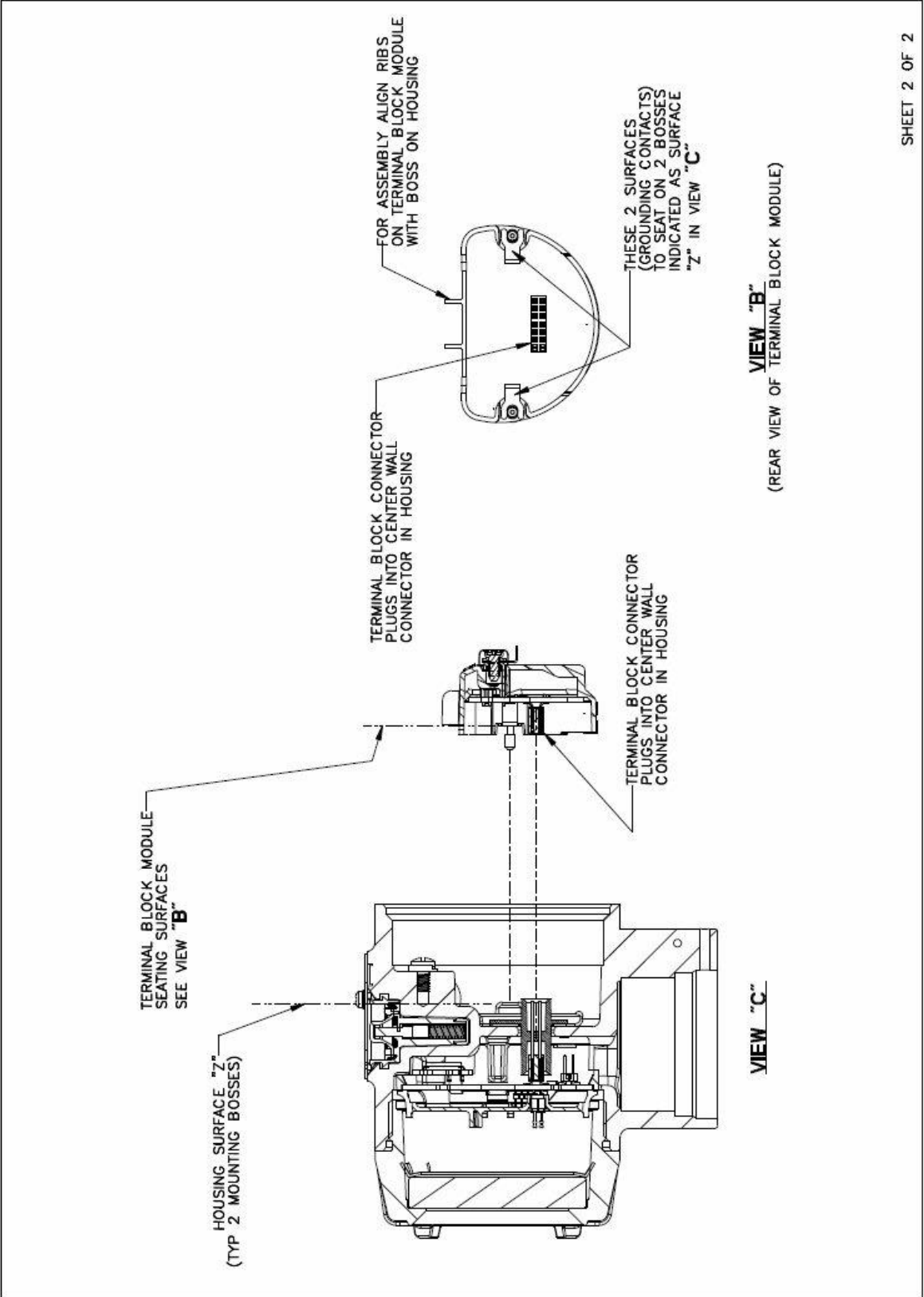

5.3 Procedures

5.3.1 Output Check Procedures

The Output Check has the following procedures:

- The Loop Test procedure checks for continuity and the condition of components in the output current loop.
- The Trim DAC Current procedure calibrates the output of the Digital-to-Analog converter for minimum (0%) and maximum (100%) values of 4 mA and 20 mA, respectively. This procedure is used for Transmitters operating online in analog mode to ensure proper operation with associated circuit components (for example, wiring, power supply and, control equipment).
- Precision test equipment (an ammeter or a voltmeter in parallel with precision resistor) is required for the Trim DAC Current procedure.
- The Apply Values procedure uses actual Process Variable (PV) input levels for calibrating the range of a Transmitter. To measure a liquid level for example, a sight-glass can be used to determine the minimum (0%) and maximum (100%) level in a vessel. The PV is carefully adjusted to stable minimum and maximum levels, and the Lower Range Limit Value (LRV) and Upper Range Limit Value (URV) are then set by commands from the MC Toolkit.



The Transmitter does not measure the given PV input or update the PV output while it operates in the Output mode.

5.3.2 Constant Current Source Mode Procedure

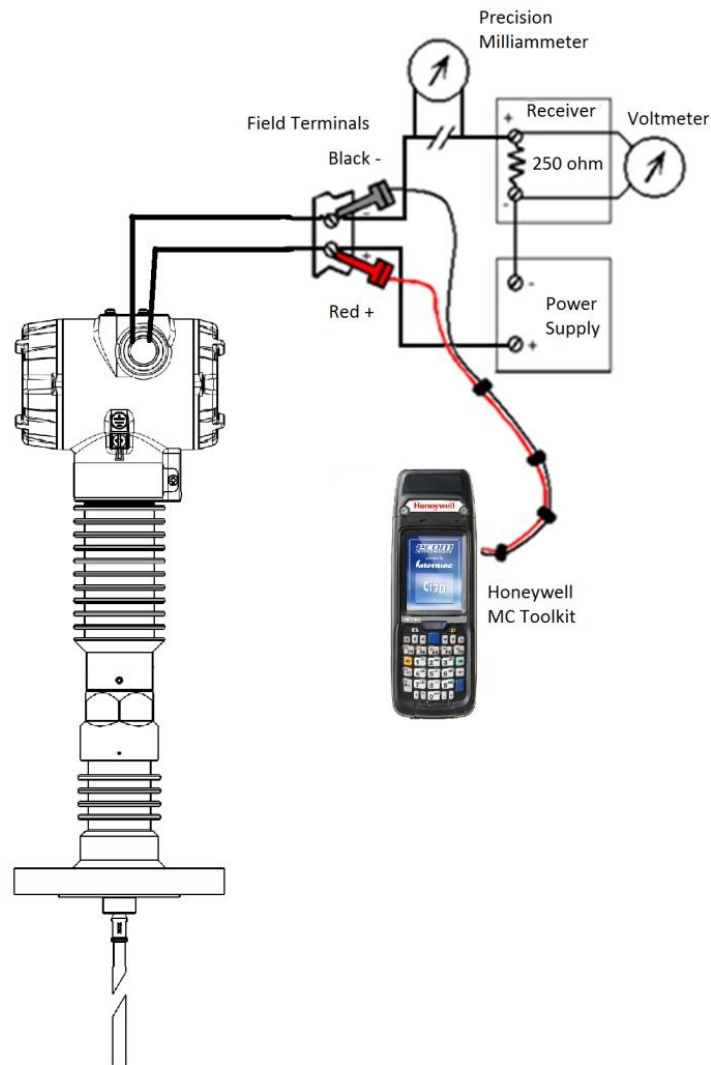

Figure 5-1: Current Loop Test Connections

1. Refer to [Figure 5-1](#) for test connections. Verify the integrity of electrical components in the output current loop.
2. Establish communication with the Transmitter. For these procedures, the values of components in the current loop are not critical if they support reliable communication between the Transmitter and the Toolkit.
3. On the Toolkit, display the **Output Calibration** box.
4. In the Output Calibration box, select the **Loop Test** button; the **LOOP TEST** box will be displayed.
5. Select the desired constant-level Output: 0%, 100%, or Other (any between 0% - 100%).

6. Select the Set button. A box will be displayed asking **Are you sure you want to place the transmitter in output mode?**



With the Transmitter in Analog mode, you can observe the output on an externally-connected meter or on a local meter.

7. Select the **Yes** button. Observe the output current at the percentage you selected in Step 5.
8. To view the monitor display, navigate back from the **LOOP TEST** display, and select the **MONITOR** display. A **Confirm** popup will be displayed.
9. Select **Yes** to continue. This concludes the Startup procedure

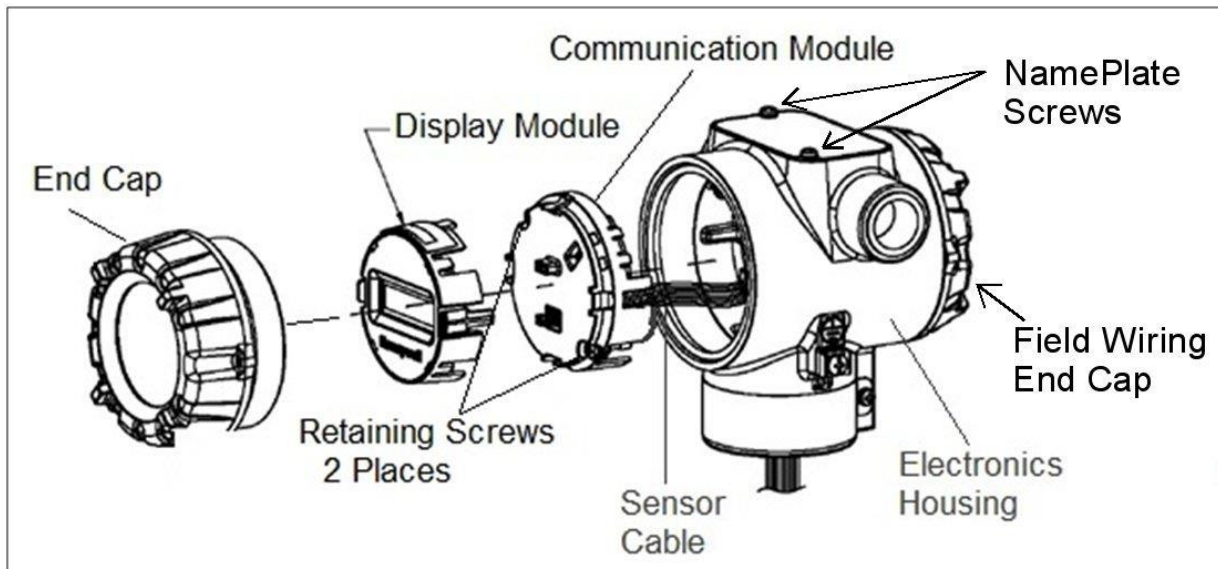

Figure 5-2: Electronic Housing Components

Note:

The example diagram does not display the 8 pin interface connector. The interface connector connects the Display Module to the Communication Module. If this is not in place the display will not receive power.

Note:

The example diagram refers to a HART transmitter, the following process is the same for FF.

5.3.3 Replacing the Terminal Block

Refer to *Installing the Terminal Block Module*, Document #34-ST-33-64.

5.3.4 Replacing the Display Assembly

Refer to *Installing the Display Module*, Document #34-ST-33-65.

5.3.5 Replacing the Communication Module

Refer to *Installing the Communication Module*, Document #34-ST-33-69.

5.4 How to replace the Sensor Housing

The Sensor Housing contains the ribbon cable that allows the Electronic Housing to gather data from the probe.

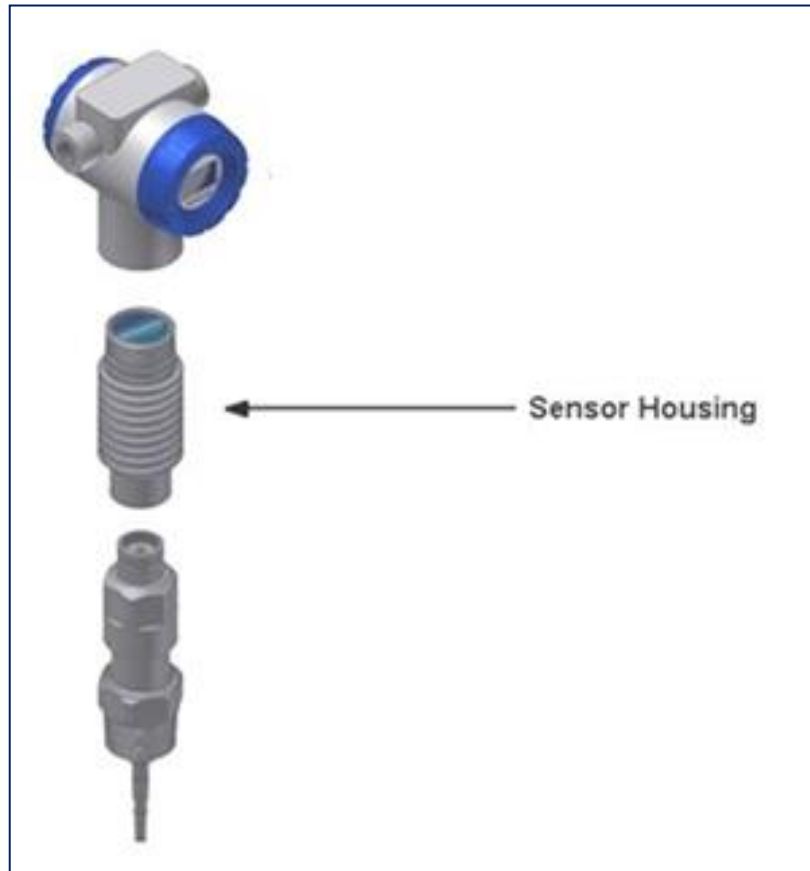

Figure 5-3: Sensor Housing



WARNING:

The Sensor Housing is attached to the Electronic Housing using a threaded connection. The Sensor Housing contains a ribbon cable it is crucial to ensure this ribbon cable is not damaged in the process.

The ribbon must be manually guided when removing the Sensor Housing from the transmitter.

Refer to [Figure 5-2: Electronic Housing Components](#)

for more information.

1. Turn OFF transmitter power. Unscrew the end cap of the Display Module. On the Display Module, remove the two setscrews. Depress the two tabs on the Display Module and remove it.

2. Unplug the ribbon cable from the Communication Module. Do not discard any of the parts.
3. Carefully unscrew the Sensor Housing from the Electronics Housing. Manually keep turning the ribbon cable to ensure the ribbon cable is not damaged or pinched.

Note:

There is an o-ring on the top of the Sensor Housing. Ensure this is retained for the new Sensor Housing.

4. Unscrew the two set screws from the base of the Sensor Housing.
5. Gently pull apart the Sensor Housing from the Process Connector.



WARNING: The Sensor Housing has a small female-to-female adapter where the Sensor Housing attaches to the Process Connector. If the new Sensor Housing was shipped with a new female-to-female adapter, use the new adapter.

6. Ensure the new female-to-female adapter is installed in the Sensor Housing.
7. Attach the Process Connector to the new Sensor Housing. Ensure the second smaller o-ring is on the Process Connector.
8. Replace the o-ring on the Sensor Housing.
9. Carefully thread the new ribbon cable into the Electronics Housing.
10. Ensure the o-ring is fitted around the top of the Sensor Housing and start to slowly screw the Sensor Housing into the Electronic Housing.



WARNING:

Do not tightly screw together the Sensor Housing into the Electronics Housing. The two parts only need to be moderately screwed together. The connection should be to the point where the o-ring is not visible. Ensure the o-ring is not pinched

11. Plug the ribbon cable into the Communication Module and return the Communication Module in the Electronic Housing. Screw in to the Electronic Housing.
12. Plug the Display Module into the Communication Module.
13. Screw the end cap into the Electronic Housing.
14. Re-insert the transmitter to the mounting. Angle as required.
15. Turn power ON.

5.4.1 Tools required.

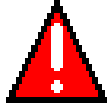

WARNING: When installed as explosion-proof or flame-proof in a hazardous location, keep covers tight while the transmitter is energized. Disconnect power to the transmitter in the non-hazardous area prior to removing end caps for service. When installed as non-incendive or non-sparking equipment, disconnect power to the transmitter in the non-hazardous area, or determine that the location is non-hazardous before disconnecting or connecting the transmitter wires.

Use this tool	For this item
AF 2.0 mm Allen key	M4 set screw for Separating Sensor Electronics Housing from Process Connector and Communications Housing
AF 1.5 mm Allen key	M3 set screw for end cap removal
Parker Super O-ring Lubricant or equivalent	Transmitter re-assembly

1. Determine transmitter Firmware version of the Sensor and Communications Modules

Sensor Firmware Version	Notes:
1.000000/1.000100	COMM PCBA and ADVANCED DISPLAY must be replaced or have firmware upgraded. TERM PCBA must be replaced if the version number in the date code is not 'C'. An example of a correct date code is shown in Figure 5-45-5
1.010000, 1.020000, and 2.000100	Sensor electronics is replaceable



Figure 5-45-5: Part Number and Date Code (D/C) label on bottom of Terminal PCBA

assembly

2. Remove power from transmitter.
3. If a new terminal assembly is also being installed follow instructions 34-ST-33-64.
The relevant part numbers are listed in Table 7-1.

GWR Level Terminator Module w/Lightning Protection Kit for HART Modules	50095191-502
GWR Level Terminator Module w/Lightning Protection Kit for FF Modules	50095191-510
GWR Level Terminator Module w/o Lightning Protection Kit for HART Modules,	50095191-501
GWR Level Terminator Module w/o Lightning Protection Kit for FF Modules	50095191-509

4. If a new Communications Module is also being installed follow instructions 34-ST-33-69.
5. Separate the sensor housing from the process connector by first loosening the 4 mm setscrews (3) and gently separating the sensor electronics housing. Do not discard setscrews or o-rings.

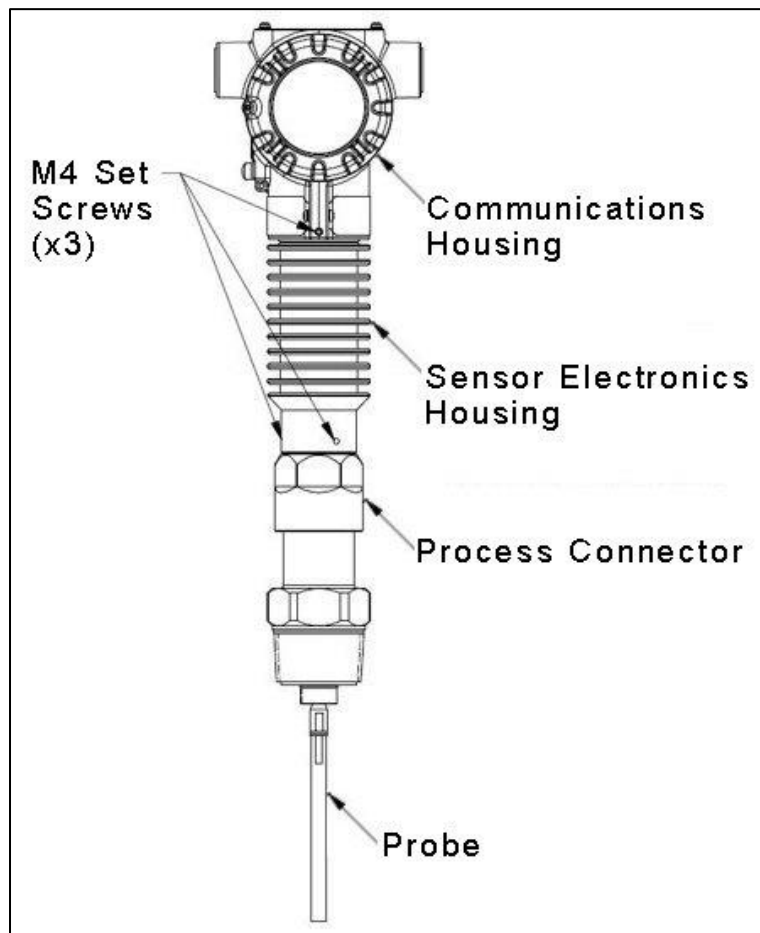

Figure 5-6: Location of sensor housing and attachment set screws

- Loosen the end cap locking screw and unscrew the end cap on the Communications Electronics side of the transmitter communications housing.

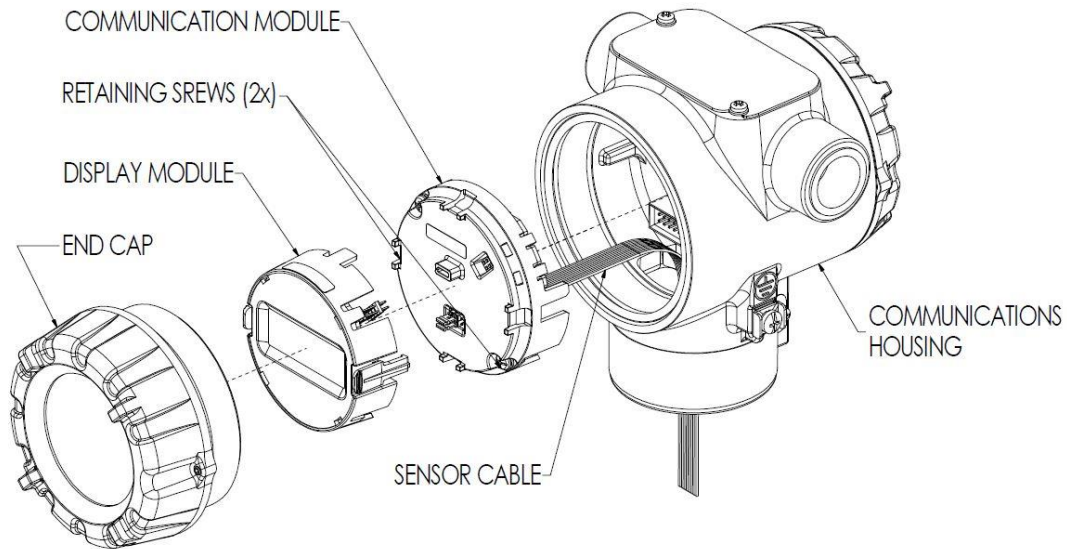

Figure 5-7: Communications Housing Assembly

- If equipped with a Display Module, carefully depress the two tabs on the sides of the Display Module, and pull it off. Ensure the interface connector is not lost. **Do not discard the Display Module, or connector.**
- Loosen the two retaining screws, and carefully pull the Communication Module from the Sensor Electronics compartment. **Do not discard the retaining set screws.**
- Carefully remove the Sensor Ribbon Cable from the "P2" connector on the Communication Module at the bottom of the Communication Module.
- Carefully unscrew the Sensor Electronics Housing from the Communications Housing.
- Carefully transfer orange o-ring from old sensor electronics housing to new housing. Clean off o-ring and apply o-ring lubricant before re-installing.
- Thread the ribbon cable of new Sensor Electronics Housing into Communications Housing.
- Screw Sensor electronics housing into Communications housing taking care not to damage the ribbon cable. The ribbon cable connector must be rotated with the sensor housing to ensure that it does not twist more than $\frac{1}{2}$ turn during the process.

Screw only as far as indicated in Figure 5-8 .

There should be 2.5mm clearance between the Communications housing and the top fin of the Sensor electronics housing. The o-ring should not be visible. Over-tightening will irreparably damage the ribbon cable. Ensure the o-ring is not pinched

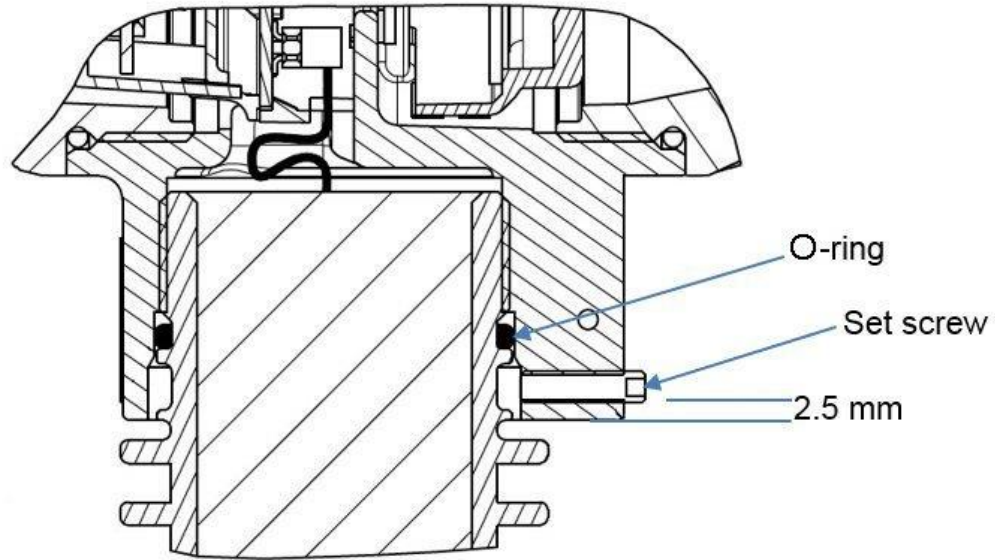

Figure 5-8: Rook Assembly



WARNING: Do not tightly screw together the Sensor Housing into the Electronics Housing. The connection should be to the point where the o-ring is not visible.

14. Tighten set screw as shown in Figure 5-8. The set-screw should not protrude from the Communications electronics housing. Protrusion indicates that the sensor housing is screwed an incorrect amount into the communications housing.
15. Carefully align and connect the Sensor Ribbon Cable to the connector “P2” at the bottom of the Communication Module. Pin 1 must be aligned with contact 1 of the ribbon cable indicated by the colored edge wire.

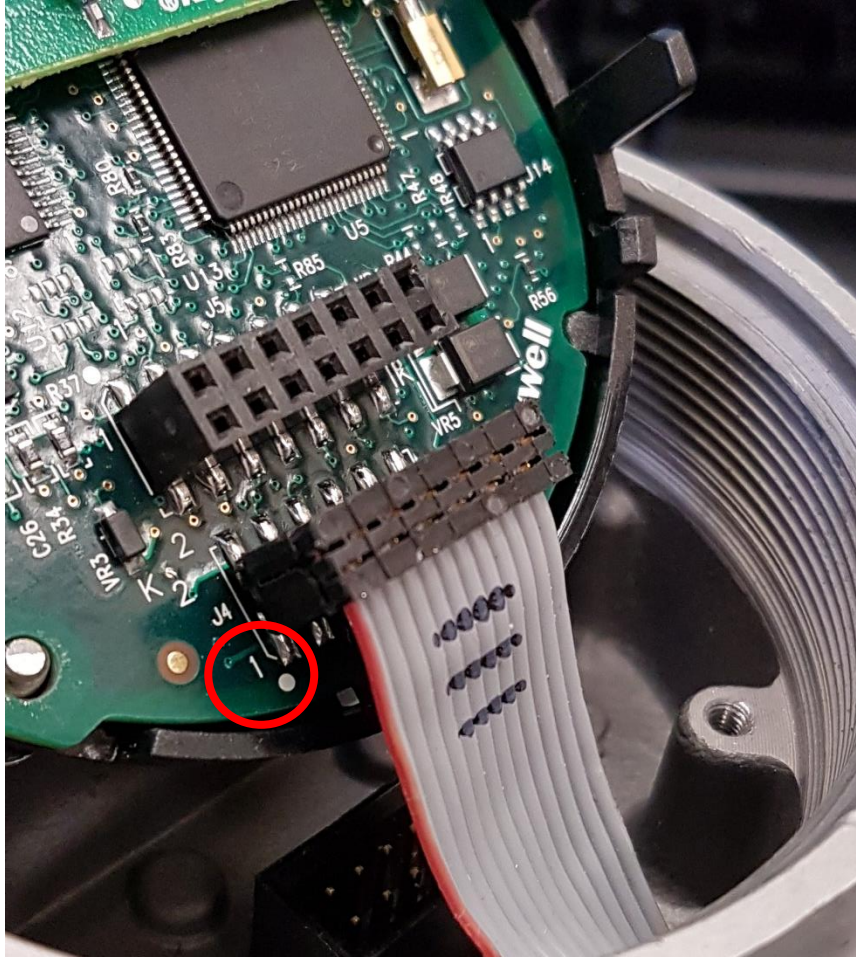

Figure 5-9: - Sensor ribbon cable

Note: Sensor ribbon cable wire aligns with pin 1 of J4 as shown. The Communication Module is then rotated 180 degrees to seat in Communications Housing.

16. Carefully, insert the Communication Module into the Electronics housing compartment. Ensure that the Sensor Ribbon Cable is not pinched.
17. Tighten the two Communications Module retaining screws.
18. If a new Communications Module is being used, duplicate the jumper settings on the original Module.
19. If applicable, re-install the Display Module as follows:
 - Orient the display as desired.
 - Install the Interface Connector in the Display Module such that it will mate with the socket for the display in the Communication Module.
 - Carefully line up the display, and snap it into place. Verify that the two tabs on the sides of the display latch.

20. Apply O-ring lubricant to the end cap o-ring before installing the end cap. Reinstall the end cap and tighten the end cap locking screw.
21. Ensure the small RF connector is seated firmly in place, on the bottom of the sensor electronics housing. See Figure 5-10.

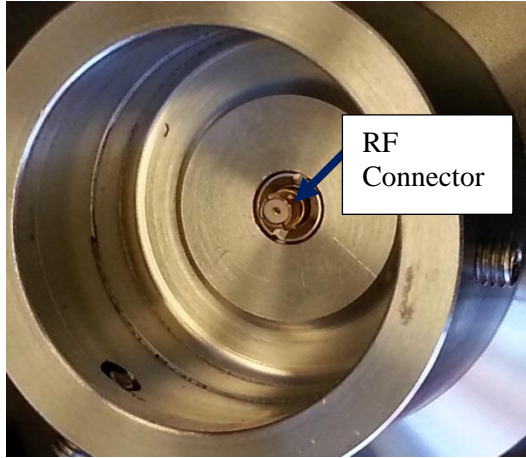

Figure 5-10: Location of RF-connector at bottom of sensor housing

22. If necessary, replace the o-ring at the top of the process connector. Apply o-ring Lubricant and carefully replace the Sensor electronics housing without pinching the o-ring. Tighten the set screws.
23. Turn ON transmitter power.
 - If the COMM Firmware version is 1.020000 the transmitter should power up and operate with no further configuration required. However, if a warning message is displayed, it may be necessary to identify if a new sensor electronics housing is being installed, or a new COMM module is being installed.
 - If the COMM Firmware version is 1.010000, the model key information will not be visible unless the information was programmed at factory. This does not affect the operation of the transmitter.
24. If upgrading transmitter from sensor firmware version 1.000x00, the transmitter configuration will need to be set. However, if a new COMM module was ordered at the same time as the sensor electronics a basic configuration will be already in place. See manuals:

Publication #	Publication Title
34-SL-25-11	SLG 700 SmartLine Guided Wave Radar User's Manual
34-SL-25-06	SLG 700 SmartLine Level Transmitter Guided Wave Radar HART© Option User's Manual
34-SL-25-07	SLG 700 SmartLine Level Transmitter Guided Wave Radar FOUNDATION Fieldbus Option Manual

Note: The transmitter stores its configuration on the COMM PCBA. Therefore, you do not need to transfer the configuration.

5.4.2 Hazardous Locations

Warning: When installed as explosion-proof or flame-proof in a hazardous location, keep covers tight while the transmitter is energized. Disconnect power to the transmitter in the non-hazardous area prior to removing end caps for service. When installed as non-incendive or non-sparking equipment, disconnect power to the transmitter in the non-hazardous area, or determine that the location is non-hazardous before disconnecting or connecting the transmitter wires.

Product Approvals: All replacement sensor electronic modules are built according to the same quality and regulatory processes as the original transmitter parts and complete transmitter. Deviating from these instructions, or using other replacement parts, may invalidate the product approvals marked on the transmitter nameplate.

Hi-Pot (Dielectric Strength) Test: The replacement sensor electronic modules are hi-pot tested at the factory prior to shipment, using a voltage of 850 V for 1 second. If applicable standards for the installation still require a hi-pot test after device repair, the voltage shall not exceed 600Vac or 850Vdc between loop terminals and case. The hi-pot test will fail with lightning protection terminal assemblies installed. The hi-pot test must only be performed with a non-lightning protected terminal assembly installed in the transmitter during the test.

The Hi-Pot test may be performed on the transmitter electronics, before re-installing on the process connector.

5.4.3 Appendix: Reconciling Model Numbers

If a spare sensor electronics housing has been used in a transmitter, it will likely have a model number which does not match the model number stored in the COMM electronics. This will cause an error.

Using three-button interface and display:

The error can be identified by selecting

Monitor

- Non-critical errors
 - The error will appear as *Model Number Mismatch*

To clear this error, select

Monitor

- Model Number

The Sensor Model Number and the Communication Model number can be displayed. To clear the error, a *Matching Source* will have to be selected. In most cases this will be the COMM module; however, in some cases Sensor module can be selected. The *Do Match* must be selected to clear the fault.

Refer to the User's manual for instructions on using the three-button interface.

Using the DTM:

The error can be identified from the Monitor, Device Status & Alarms screen. The error is identified as *Model Number Mismatch* (see Figure 5-11)

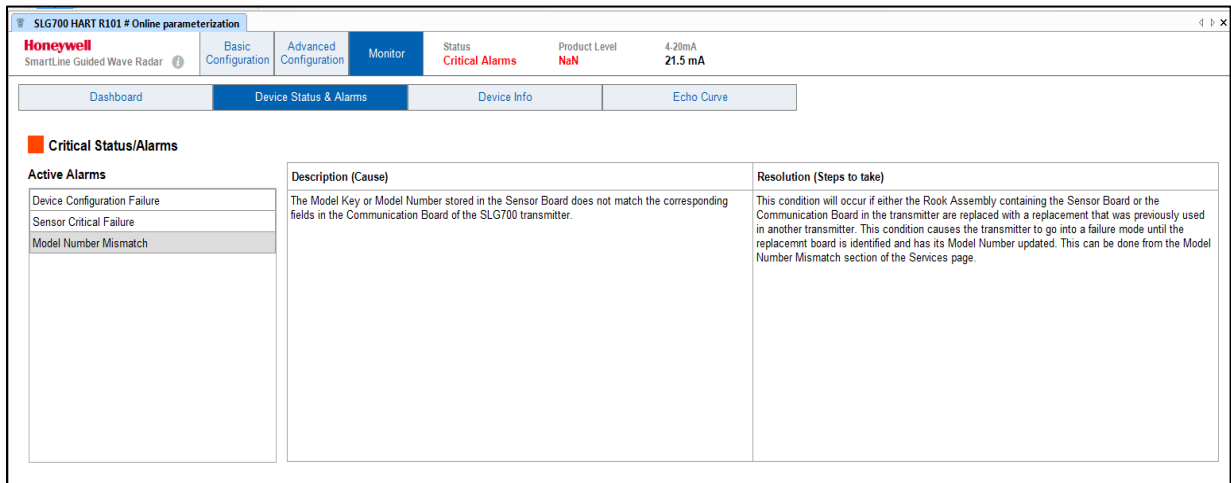

Figure 5-11- Model Number Mismatch Critical Error

To clear this error, navigate to the *Advanced Configuration, Services* tab and select *Reconcile Model Numbers*. In most cases, it will be appropriate to select *Use Comm Module Model Number* to clear the error. After selection, the transmitter will restart.

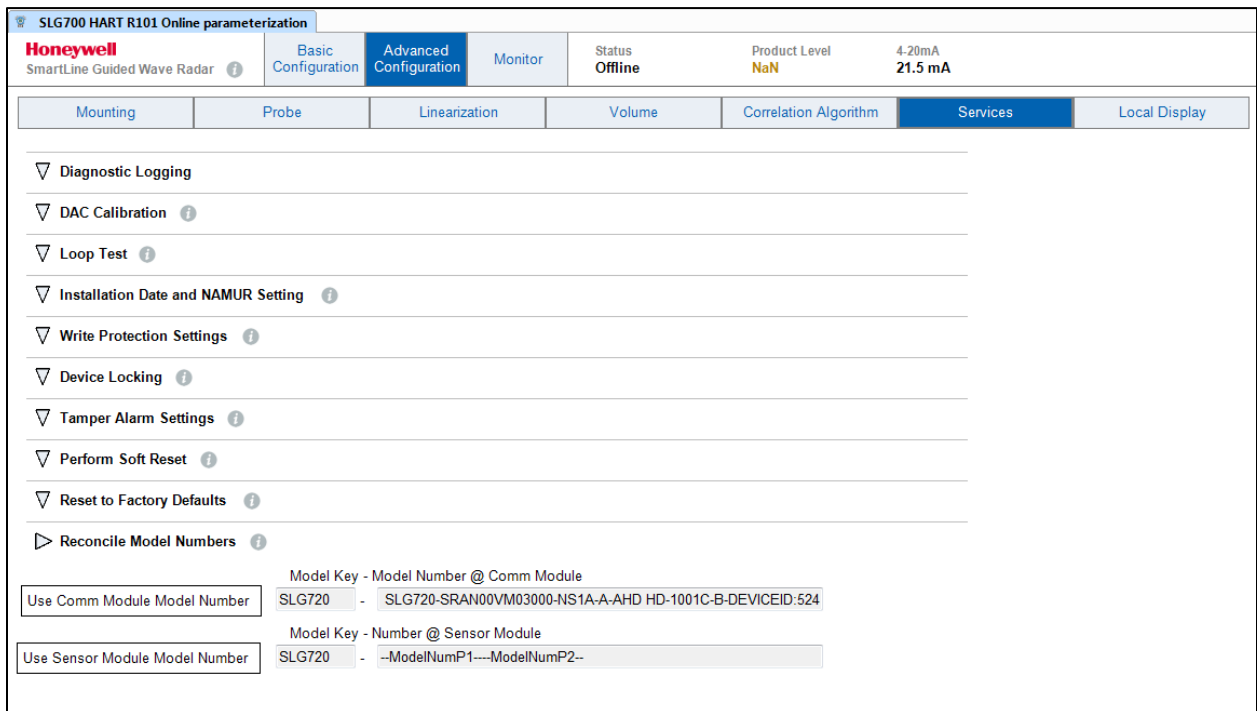
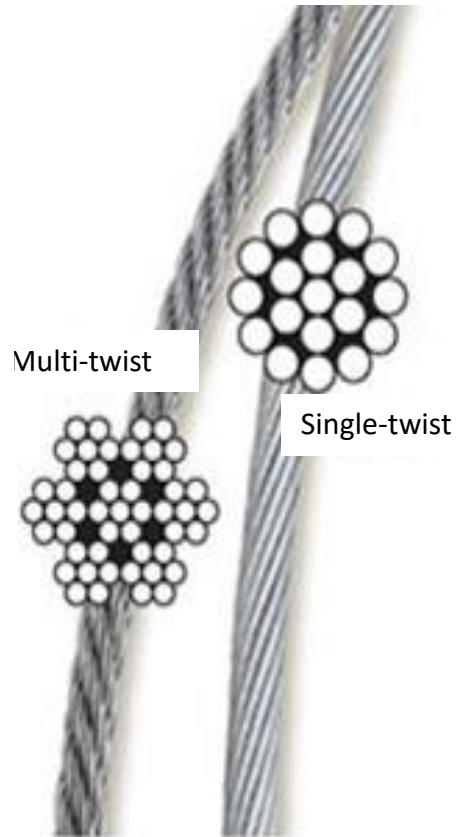

Figure 5-12 - Reconcile Model Numbers feature

5.5.2 Procedures

Step – 1: Determine the wire type of the wire probe, multi-twist or single twist:



Step – 2: Determine the sensor firmware version of the transmitter (the procedure will vary depending on the user interface. Consult the User's Manual, the HART Manual, or the FOUNDATION Fieldbus Manual. See references at the front of this manual.

- a) 1.000000/1.000100: a change of probe type to multi-twist wire is not supported. The transmitter must first be upgraded to a more recent release then the instructions applicable to that release will apply.
- b) 1.010000: a change of probe type to multi-twist wire is supported. Either a HART or FF user interface is required to make the appropriate settings change.
- c) 1.020000 and higher: a change of probe type to multi-twist wire is supported with all interfaces.

Step – 3: Remove existing probe using appropriate wrenches. Remove the existing end-of-probe hardware if it is needed for the new probe.

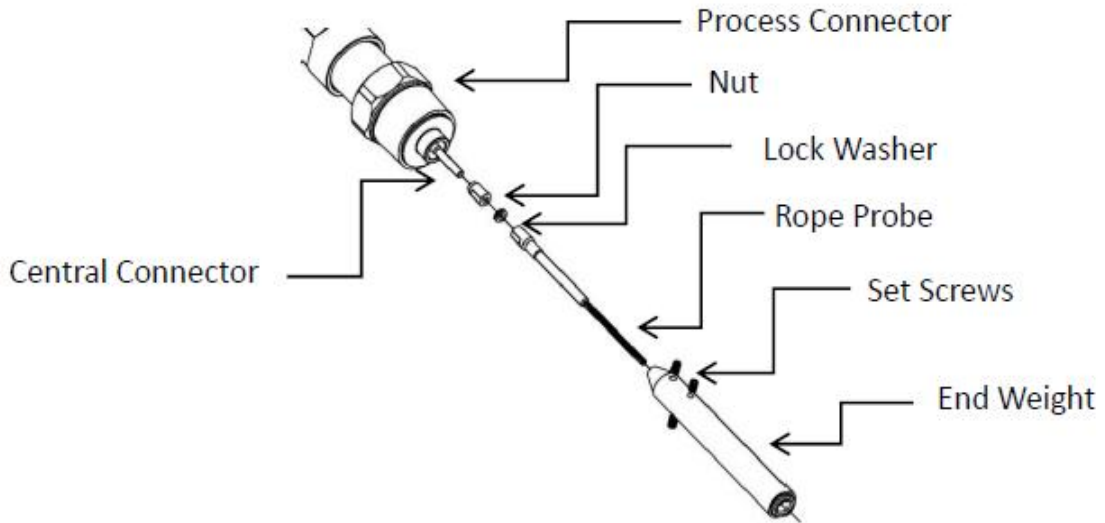

Step – 4: Attach new probe

Step	Action
1	Fully thread the nut onto the central conductor. Using a lock washer, thread the wire swage on to the central conductor. Torque the nut against probe and lock washer to secure the connection. Note: Tighten the wire stud and nut to the following torque: - SLG720 6.0 Nm (4.4 ft-lbs) - SLG726 15 Nm (11 ft-lbs)
2	If applicable, insert wire probe into end weight. Tighten the 3 set screws to secure end weight to wire probe. Note: Torque set screws to 6 Nm (4.4 ft-lbs)
Note: For flanged SLG726 models, ensure the nut does not intrude into the bore of the process connector. See image below for acceptable spacing.	

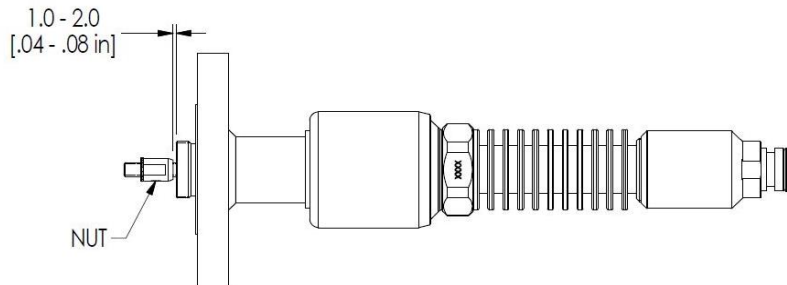

If the probe length has changed measure the length from the reference plane to the end of the probe. **Keep in mind that for a wire probe with an end weight, the probe length is measured from the transmitter reference plane to the top of the end weight.** If the wire probe is untrimmed, it is possible to determine the correct probe length from the factory by following these steps:

Refer to the underlined characters in the spare probe model number. For example: SLGP2A-C-SW_____X X X X X-_-_-_. The probe length is used by the transmitter software shown in Table 5-1. Find the matching model number pattern, calculate the probe length accordingly, and enter into transmitter using user the interface.

Table 5-1: Probe length calculated from spare probe model number.

Spare Probe Model Number	Probe Length (mm)
SLGP20-_-SW_____XXXXX-_-_- SLGP26-F-SW_____XXXXX-_-_-	XXXXX - 150
SLGP26-T-SW_____XXXXX-_-_-	XXXXX - 125

Step – 5: Follow the instructions pertaining to the firmware version.

Instructions pertaining to R1.010000 firmware:

- If a field background is being used, disable it.
- Ensure the probe type is WIRE.
- If the probe length was changed, ensure that the correct probe length is being used and reset the transmitter (see above for instructions on determining the correct probe length).
- An adjustment will have to be made to the propagation factor and vapor attenuation depending on the wire type.

Wire Probe Type	Model (Probe/Transmitter)	Propagation Factor	Vapor Attenuation
SINGLE-TWIST WIRE	SLGP20 / SLG720	1.0000	0.02636
	SLGP26 / SLG726		
MULTI-TWIST WIRE	SLGP20 / SLG720	0.9985	0.03300
	SLGP26 / SLG726	0.9985	0.04145

- If a field background is desired, a new field background can be taken.

Instructions pertaining to R1.020000 and higher firmware:

- a) If a field background is being used, disable it.
- b) Using a user interface, select the correct Probe type from the table below:

Wire Probe Type	Probe type selection
SINGLE-TWIST WIRE	WIRE
MULTI-TWIST WIRE	MULTI-TWIST WIRE

- c) If the probe length was changed, ensure that the correct probe length is being used and reset the transmitter (see above for instructions on determining the correct probe length).
- d) If a field background is desired, a new field background can be taken.

Instructions pertaining to be included with replacement of multi-twist wire probes:

- a) Refer to Revision 4.0 of the SLG 700 SmartLine Guided Wave Radar User’s Manual. References below will be to this revision of the manual.
- b) Determine the sensor firmware version of the transmitter (the procedure will vary depending on the user interface. Consult the User’s Manual, the HART Manual, or the FF Manual.
 - i. 1.000000/1.000100: a change of probe type to multi-twist wire is not supported.
 - ii. 1.010000: a change of probe type to multi-twist wire is supported but cannot be completed only with only three-button/display operation. Either a HART or FF user interface is required.
 - iii. 1.020000 and higher: a change of probe type to multi-twist wire is supported with all interfaces.
- c) Tools required – refer to section [5.5.1](#)
- d) Remove existing probe using an AF 8 mm wrench on the locknut and an AF 7 mm wrench on the probe. Remove the existing end-of-probe hardware if it is needed for the new probe.
- e) Attach new probe – if the probe length has changed measure the length from the reference plane to the end of the probe. Keep in mind that for a wire probe with an end weight, the probe length is measured from the transmitter reference plane to the top of the end weight.
- f) If a field background is being used, disable it.
- g) If the sensor firmware version is R1.020000 or higher, change the probe type to MULTI_TWIST_WIRE, otherwise ensure it is WIRE.
- h) If the probe length was changed, ensure that the correct probe length is being used and reset the transmitter.
- i) If the sensor firmware revision is R1.010000, an adjustment should be made to the propagation factor and vapor attenuation (correlation parameter).
- j) The propagation factor should be set to 0.9985 and the vapor attenuation should be set to 0.03300 if the model is SLG720 and to 0.04145 if the model is SLG726.

5.6 Trimming Coaxial Probes

5.6.1 Tools required

Required tools depend on options ordered.

For this item	Use this tool
Coaxial probe outer tube removal/installation	Pipe wrenches (2x)
M3 set screw for coaxial coupler (SCA)	AF 1.5 mm Allen key
Inner rod probe	AF 7 mm wrench (2x)
Inner rod probe nut	AF 8 mm wrench
Mounting thread ¾" and 1" process connector	AF 40 mm wrench
Mounting thread 1-½" process connector	AF 50 mm wrench
Mounting thread 2" process connector	AF 60 mm wrench
Coaxial probe outer tube threads (SCA)	Process compatible thread locking compound (i.e. Loctite 242) ¹
Rod and tube trimming	Metal saw
Tool to drill hole in outer tube	Drill and 6.0 mm drill bit/drill press

¹ Thread locking compound is recommended. The thread locking compound must be process compatible

5.6.2 Procedure

The Coaxial probe consists of an inner rod conductor and a coaxial outer tube shield. To trim the coaxial probe to required length, both inner rod and coaxial outer tube need to be trimmed off by the same amount.

Step – 1: Turn off transmitter power.

Step – 2: Remove transmitter from installed location.

Step – 3: Depending on the length of the coaxial probe the outer tube may be constructed from a single length of tube or be assembled using several tube segments joined to each other using tube couplers. The amount of probe to be trimmed will dictate the extent of disassembly required. Starting from the end of the probe farthest from the process connector, remove the appropriate number of outer tube sections to be able to complete the trimming operation. If the probe is under 2.0 m in length, it will be secured to the process connector by an internal thread. Use a wrench to hold the process connector by its flats and a pipe wrench to unscrew the outer coaxial tube. If the probe is over 2.0 m in length, the section of tube to be trimmed may be secured by a tube coupler. To release the tube, loosen the two M3 set screws holding the coupler in place, then use two pipe wrenches to unscrew the tube from the coupler.

Note: if only a small length of the probe requires trimming, only the end segment of the tube will need to be removed from the assembly.

Step – 4: The inner rod of a coaxial probe is constructed out of 1.0 m rod segments. If the coaxial probe is under 1.0 m long, there will only be one rod. Otherwise, there will be at least one rod segment and a single rod end segment. The end segment will have only one threaded end. Determine how many rod segments need to be removed to complete the trimming operation. Use two 7 mm wrenches to unscrew the rods from each other, taking care not to misplace the lock washer and M5 x 20 mm stud holding the rods together. If only a small length of the probe requires trimming, only the end segment of the rod will need to be removed from the assembly.

Step – 5: Mark and trim the relevant outer tube and rod segments. Avoid trimming the coupler region of the outer tube and internal thread region of the inner rod (flat area). Refer to [Figure 5-13](#).

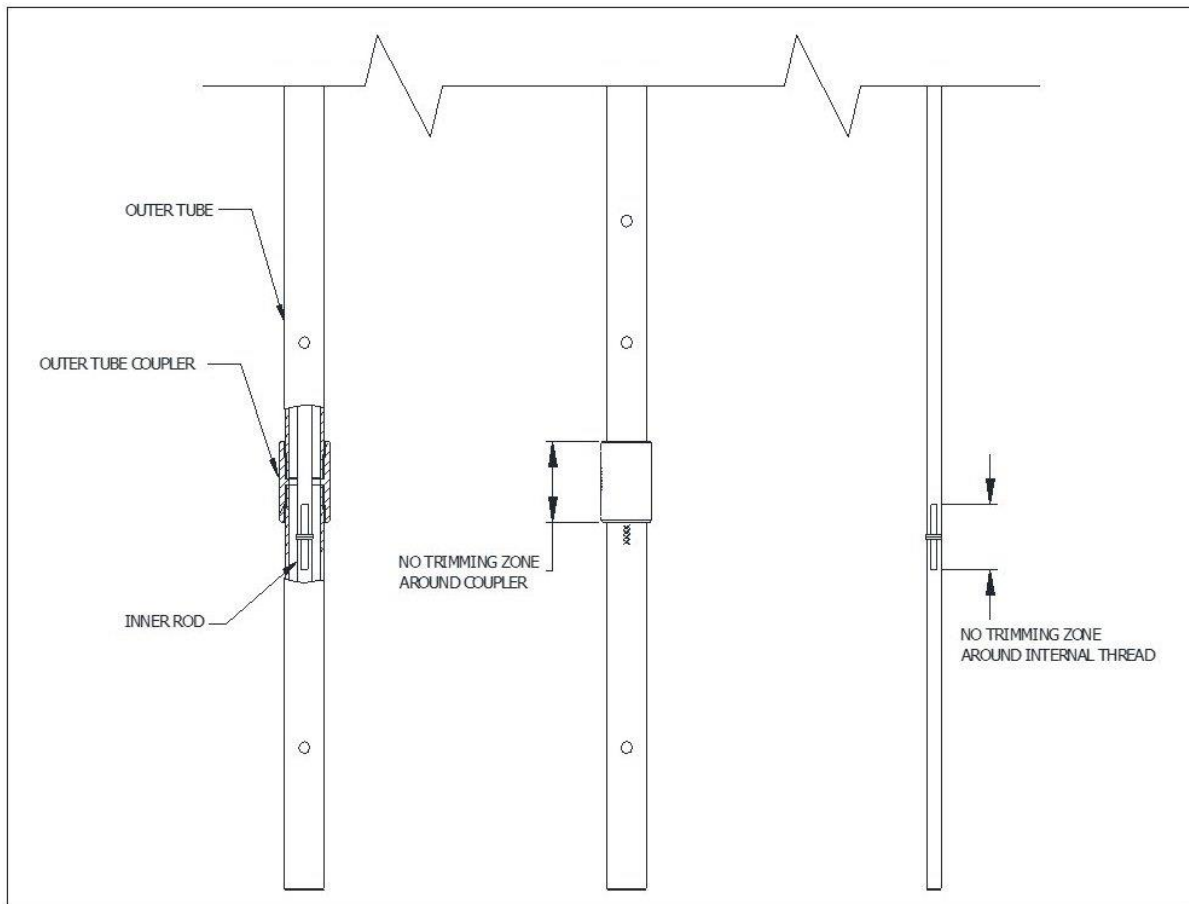

Figure 5-13 - No Trimming Zones on Outer Tube and Inner Rod

Step – 6: Drill a 6.0 mm hole through the end of the outer tube at location shown in [Figure 5-14](#).

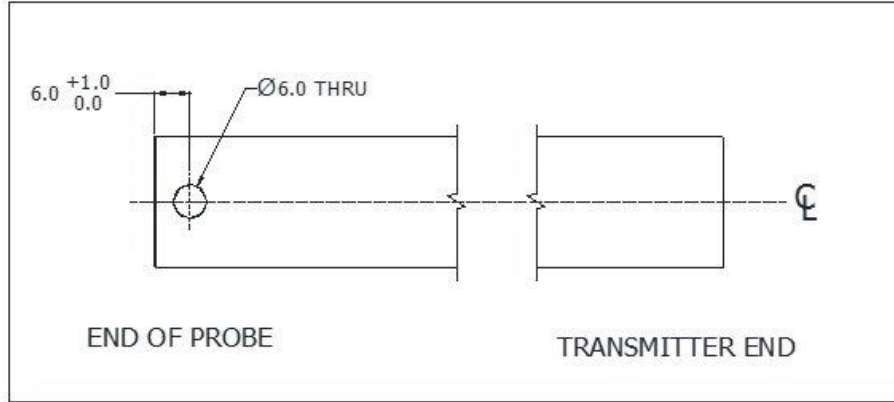

Figure 5-14 - Drill Hole Position on Outer Tube

Step – 7: Reassemble the rod probe. Tighten each rod connection to 6.0 Nm (4.4 ft-lbs).

Step – 8: Reassemble the outer coaxial tube. Tighten each tube segment to 30 Nm (22 ft-lbs), replacing the M3 set screws into the coaxial tube couplers as required. Tighten M3 set screws to 1.0 Nm (8.8 in-lbs).

Step – 9: Insert the new spacer (HPN 50126585-001) provided by the Coaxial Probe Trimming Kit (HPN 50125208) into the end of tube. Align the holes in the end spacer with the newly drilled holes in the outer tube and insert the two pins (HPN 50126585-002) provided by the Coaxial Probe Trimming Kit. Refer to Figure 5-15.

Step – 10: Re-configure the probe length in sensor setup according to the SLG700 User's Manual 34-SL-25-11.

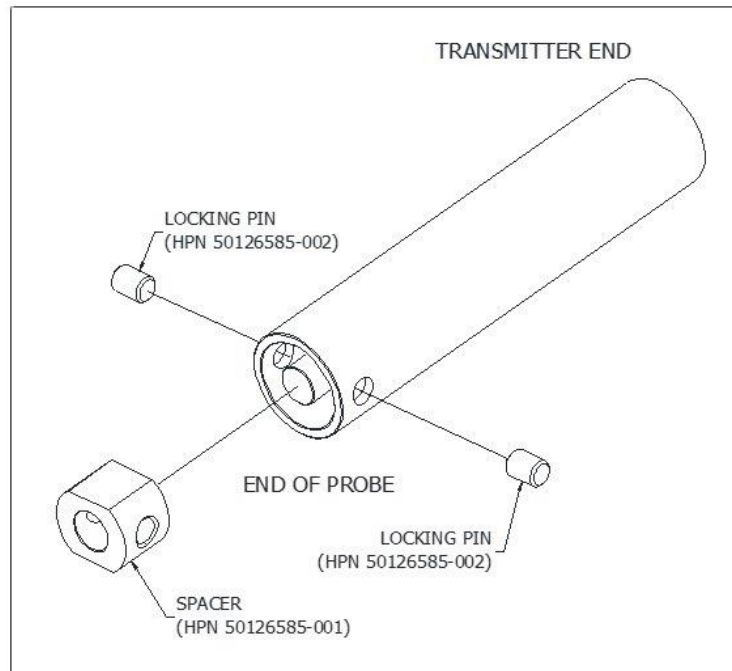

Figure 5-15 - Spacer and Locking Pin Installation

5.7 Saturated Steam Probe Installation

5.7.1 Tools required

Required tools depend on options ordered.

For this item	Use this tool
Coaxial probe outer tube removal/installation	Pipe wrench
Rod probe (16 mm) (SRK, SRL, SRC)	AF 14 mm wrench
Rod probe nut (16 mm)	AF 14 mm wrench
Saturated steam reference rod (22 mm)	AF 20 mm wrench
Saturated steam nut (22 mm)	AF 20 mm wrench
Mounting thread 1-1/2" process connector (SLG726)	AF 60 mm wrench
Coaxial probe outer tube threads (SCB)	Process compatible thread locking compound (ie Loctite 242) ¹
Rod trimming	Metal saw

¹ Thread locking compound is recommended. The thread locking compound must be process compatible.

5.7.2 Procedure

Saturated steam application is available with SLG726 rod and coaxial probes. The retrofit kit comes with a nut, a steam reference rod, a stud and two washers. Prior to installing the saturated steam hardware, the current SLG726 probe needs to be trimmed to maintain the same overall probe length after the saturated steam hardware is installed. Whether the probe type is rod or coaxial, only the rod (inner rod for coaxial probe) needs to be trimmed. The following instructions detail the probe trimming and hardware installation procedures.

Step – 1: Turn off transmitter power.

Step – 2: Remove transmitter from installed location.

Step – 3: For coaxial probes, depending on the length of the coaxial probe, the outer tube may be constructed from a single length of tube or be assembled using several tube segments joined to each other using tube couplers. Remove the retaining ring and the end spacer from the end of the tube. If the probe is under 2.0 m in length, it will be secured to the process connector by an internal thread. Use a 60 mm wrench to hold the process connector by its flats and a pipe wrench to unscrew the outer coaxial tube. If the probe is over 2.0m in length, starting from the end segment, loosen the two M3 set screws holding the couplers in place and then use two pipe wrenches to unscrew the tubes from the coupler.

Step – 4: Use two 14 mm wrenches to unscrew the rod assembly from the nut. Remove and discard the old nut and washer.

Step – 5: The steam reference rod comes with 0.3 m or 0.5 m lengths. To maintain the same overall probe length after the steam reference rod is installed, the old rod probe needs to be trimmed off the same amount as the reference reflector rod length. The rod probe is either constructed out of a single piece, or out of multiple segments joined together using studs and lock washers. Determine how many rod segments need to be removed from the rod probe assembly to complete the trimming operation. Use two 14 mm wrenches to unscrew the rods from the rest of the assembly, taking care not to misplace the lock washer and M10x30 stud holding the rods together.

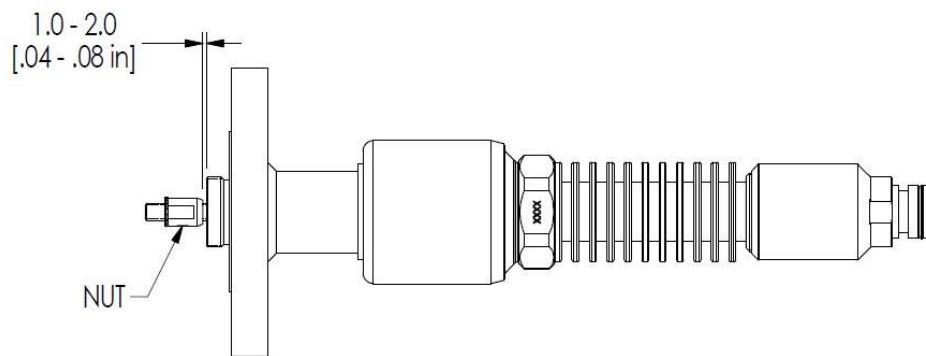

Figure 5-16 - SLG726 flanged process connection, probe nut installation position, mm [in]

Step – 6: Measure 0.3 m or 0.5 m (determined by the steam reference rod length included in the kit) from the probe unthreaded end, mark and trim the relevant rod segment using a metal saw.

Step – 7: Reattach the trimmed rod to the rest of the probe assembly using the M10x30 stud and lock washer. Tighten the rod connection to 15.0 Nm (11 ft-lbs).

Step – 8: Thread the saturated steam application nut included in the retrofit kit to the center conductor, tapered end towards the process connector. For flanged process connectors, ensure the nut position is as shown in Figure 5-16. Place a lock washer included in the retrofit kit between the locknut and the steam reference rod. Torque the connection to 15 Nm (11ft-lbs).

Refer to Figure 5-17.

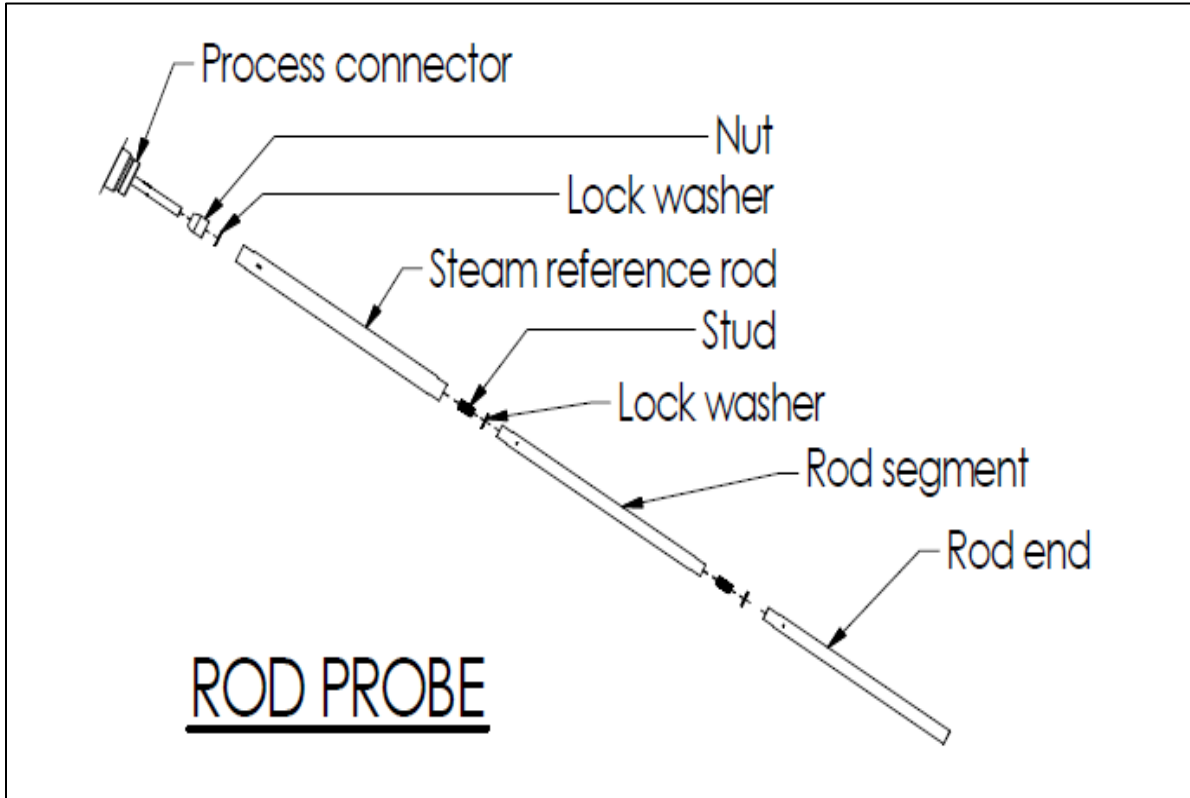

Figure 5-17 - Saturated steam application rod probe assembly

Step – 9: Reassemble the rest of the rod probe using the lock washer and M10x30 stud included in the retrofit kit.

Step – 10: For coaxial probe, slip the coaxial outer tube over the rod and tighten to the process connector. Torque the connection to 30 Nm (22 ft-lbs). It is recommended that a process compatible thread locking compound (i.e. Loctite 242) be used on the outer conductor threaded joints. Install end spacer between central conductor and outer tube in the counterbore. Secure end spacer using the retaining ring. Refer to Figure 5-18.

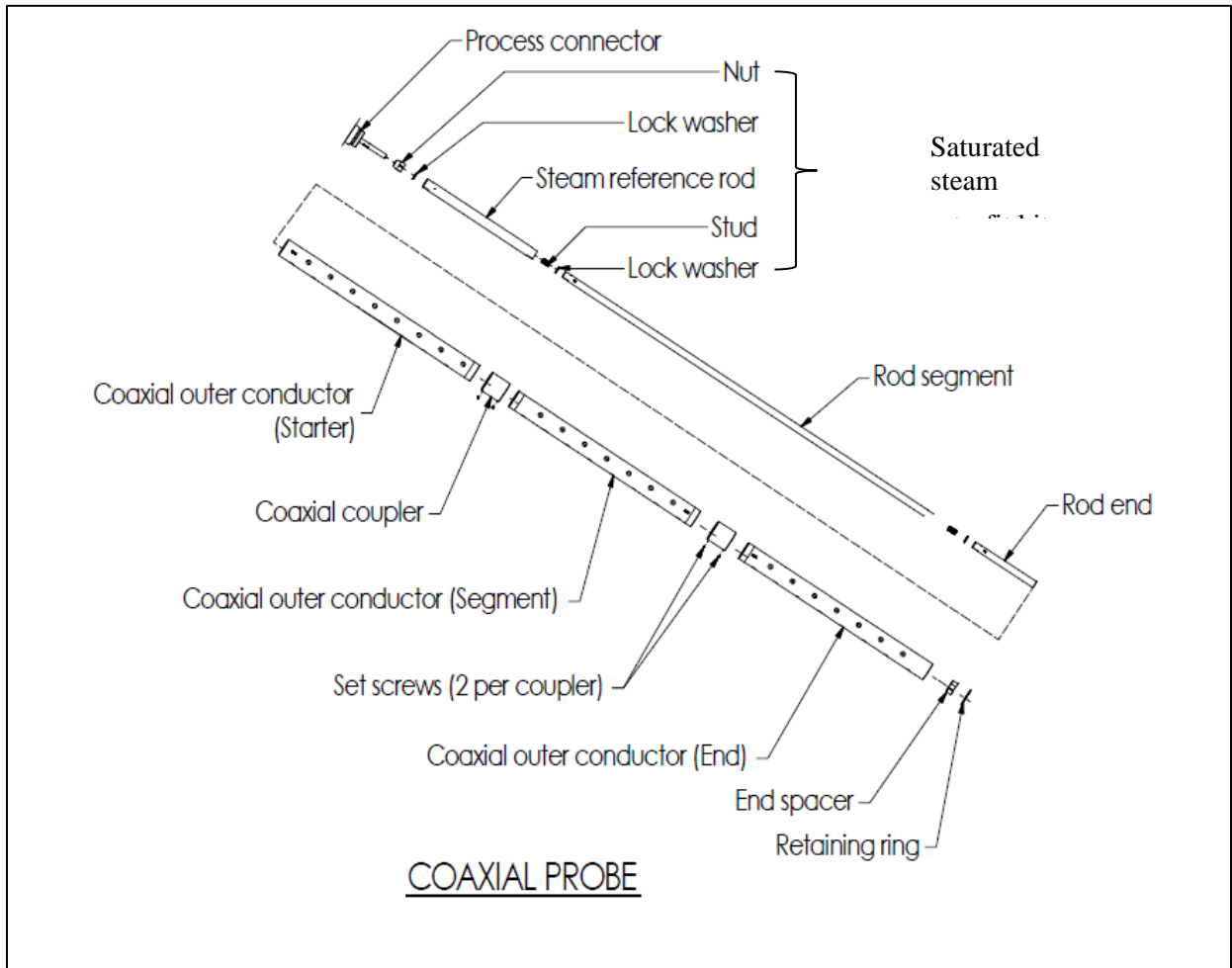

Figure 5-18 - Saturated steam application coaxial probe assembly

6 Troubleshooting

All troubleshooting should be performed by trained and qualified personnel.

Troubleshooting of hardware failures should be performed by replacement of corresponding modules. Measurement troubleshooting should be performed based on reference measurements and internal diagnostics. The following components may be replaced for troubleshooting in the field:

- Probe and / or end weight
- Centering disk
- Process connector
- Locking elements for probe mounting, for example, nuts, lock washers and set screws.
- Display module
- Terminal module
- Communication module



ESD HAZARD: Danger of an electro-static discharge to which equipment may be sensitive. Observe precautions for handling electrostatic sensitive devices (ESD).

6.1 Error Messages

Self-explanatory error descriptions (not only error code) in an end user selected language can be accessed using the local display, handheld device, or provided software tools (DD, DTM).

6.1.1 Diagnostics

When a Critical Diagnostic is present in the Transmitter, the Advanced Display will show a screen with heading “Critical Diag” and beneath it a description of the condition. These screens will be inserted into the normal screen rotation and displayed between the user-defined operator screens.

The standard diagnostics are reported in the two basic categories listed in Table 6-1. Problems detected as critical diagnostics drive the analog output to the programmed burnout level for HART protocols only.

Problems detected as non-critical diagnostics may affect performance without driving the analog output to the programmed burnout level. Informational messages (not listed in Table 6-1) report various Transmitter status or setting conditions.

The messages listed in Table 6-1 are specific to the Transmitter, exclusive of those associated with the HART protocol. HART diagnostic messages and additional diagnostic capabilities are listed and described in the *SLG 700 SmartLine HART Option User Manual*, Document #34-SL-25-06.

Table 6-1: SLG 700 Standard Diagnostics Messages

Critical Diagnostics (Failure Conditions)	Description	Resolution
Active Diags	Read-only field. Displays the number of status flags in the given category which are currently in the Active or Alarm/Warning state.	N/A
Sensor Module	Displays a status for the sensor.	N/A
Comm Module	Displays a status for the communications module.	N/A
Sensor Comm	Displays a status for the sensor communications.	N/A
Detail Diag	This is a read-write parameter which can be changed if you know the Display Password (when enabled).	N/A
Sensor Int RAM	Displays a status of the internal RAM on the sensor.	Electronics fault. Repower the unit to clear the fault. If error reoccurs, replace the sensor electronics.
Sensor Ext RAM	Displays a status of the external RAM on the sensor.	
Sensor Flash CRC (Cyclic Redundancy Check)	Runs a background check on bits in the database. Error messages communicate differences in encountered bits in the database.	
Sensor Pwr Vosc	Failure encountered in sensing sector.	
Sensor Pwr 2.5V	Failure encountered in sensing sector.	
Sensor Pwr 3.3V	Failure encountered in sensing sector.	
Sensor Pwr Accum	Displays a status of the power accumulator.	Electronics fault. Repower the unit to clear the fault. If error reoccurs, replace the sensor electronics.
Sensor Execution	Displays a status of sensor performance.	
Sensor Oscillator	Failure encountered in sensing sector.	
Factory Mode	Indicates the mode in which the transmitter is currently running. Factory mode allows users to run HART commands.	Execute HART commands to exit factory mode.

Non-Critical Diagnostics (Warning Conditions)	Description	Resolution
Active Diags	Displays a numeric value of the current count of non-critical status bits that have been set.	N/A
Supply Voltage	Displays a status of the power voltage.	Ensure the voltage on the terminals are within operational specifications.
Elec Module Temp	Displays a status of the sensor electronics.	Bring the sensor within range and reset the power.
PV Range	Displays a status of the Loop PV is within or outside the configured URV and LRV.	PV Out of Range Any of the following conditions can cause this failure: <ol style="list-style-type: none"> 1. Sensor Overload or Fault or Redundant Characterization Calculation Error. 2. Check range and, where required, replace transmitter with one that has a wider range. Sensor may have been damaged. 3. Check the transmitter for accuracy and linearity. 4. Replace the sensor and recalibrate, where required.
Sensor Over Temp	Displays a status of the temperature of the sensor electronics.	If the temperature is outside the configured range, bring the temperature within the range and reset or repower.
Prod Sgnl Str	Displays a status of the quality of the signal strength.	Read the echo curve and configure the algorithm and the dielectric constant.
Prod Sgnl Qlty	Displays a status of the quality of the signal.	
Upper Product Signal Strength	Displays the status of the strength of the signal monitoring the upper product.	
Upper Product Signal Quality	Displays the status of the quality of the signal monitoring the upper product.	
Lower Product Signal Strength	Displays the status of the strength of the signal monitoring the lower product.	
Lower Product Signal Quality	Displays the status of the quality of the signal monitoring the upper product.	
Blk Dist Hi Zone	Bulk Distance High Zone The distance within the upper blocking range.	Theses parameters display physical locations within the container where measurements are not accurate.
Blk Dist Lo Zone	Bulk Distance Low Zone The distance within the lower blocking range.	

6.2 Diagnosing SLG720 Coaxial Probe misassembly



There have been a number of instances of SLG720 coaxial probes being misassembled in the field. This document is intended to help diagnose these issues; hopefully, before transmitter installation.

Issues:

1. Spacer movement: if sufficient care has not been applied during assembly, the spacers, normally in place every meter, can move from the lock washers on which they are placed. Often these lock-washers can push the central conductor against the inside of the tube. This will result in false levels being detected where the central conductor touches the outer tube.
2. Nut placement: if the nut locking the central conductor to the process connector is missing or misassembled, it can cause false tank full alarms.
3. Bent probe

Mechanical Inspection:

1. The central conductor should be close to the center of the tube for its entire length. Especially close to the PTFE spacers which are placed every meter. If the probe is placed horizontally so that the holes are also horizontal, it should not be possible to see more than a little bit between the two opposing holes.

	
Spacer is missing – can see between opposing holes in coaxial tube	Spacer is in place – can only see a minimal amount between opposing holes.

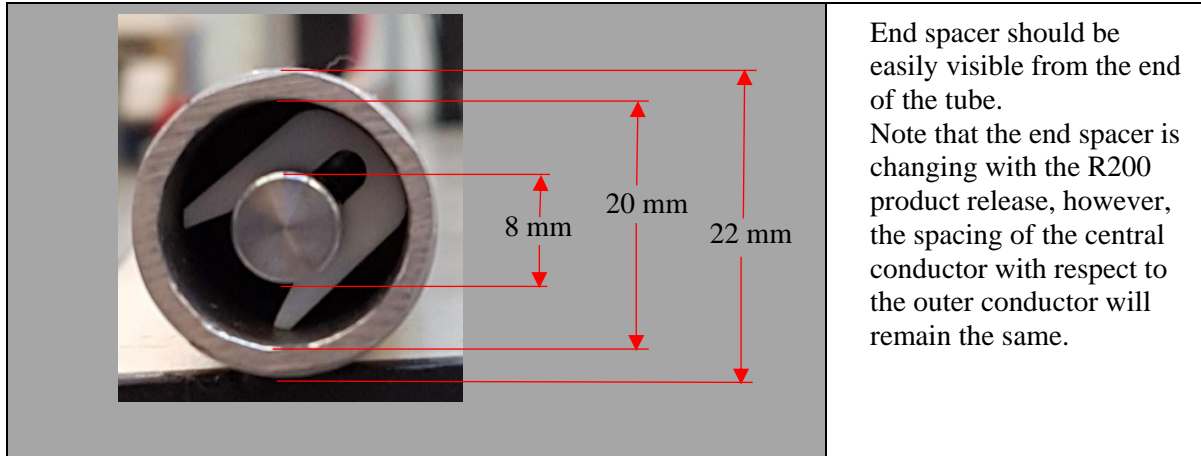

In some cases, the spacers may be jammed between the inner conductor and outer tube. If you suspect this might be the case, it is possible to diagnose by measuring from the outside of the tube to the central conductor using the depth gauge on a micrometer. The distance expected is (7 ± 2) mm.

2. There should be a nut and Nord-lock lockwasher on the threaded central conductor of the process connector. The tapered end of the nut should face the body of the process connector and the flat end should be in contact with the lockwasher.

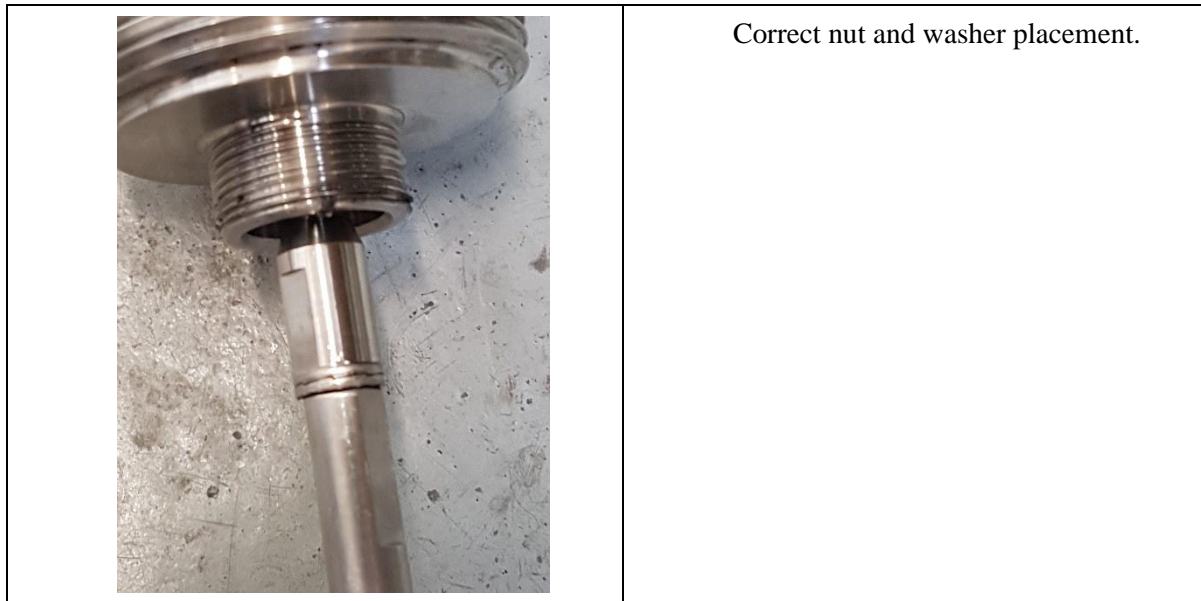

3. Each section of the tube should be straight to within 2 mm.

Echo curve inspection (note: a DD or DTM interface is required to acquire echo curves):

1. A misplaced spacer will normally appear as a false level at the 1, 2, 3, 4, 5, or 6 m position.



Misplaced spacer: The red arrow points to the position where the central conductor is likely touching the outer tube. The point of contact is ~2 m; however, since the level is higher than this position, the false reflection appears further away due to the index of refraction effect.

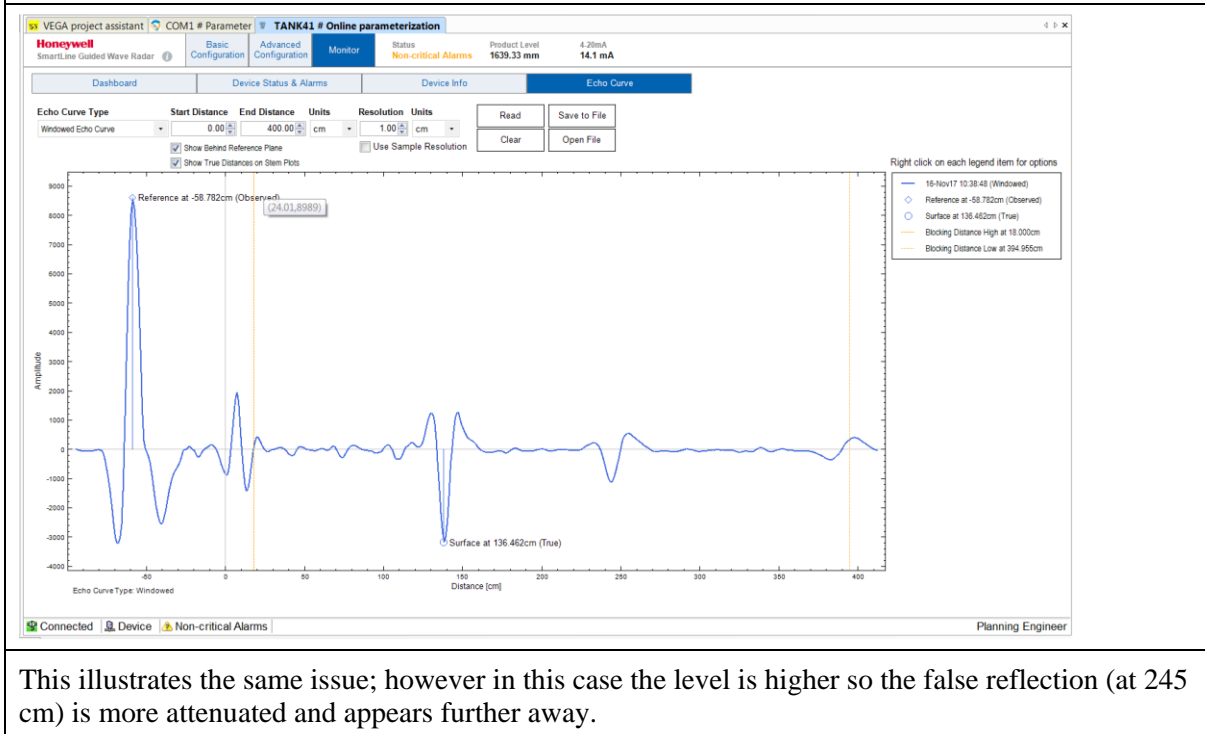

This illustrates the same issue; however in this case the level is higher so the false reflection (at 245 cm) is more attenuated and appears further away.

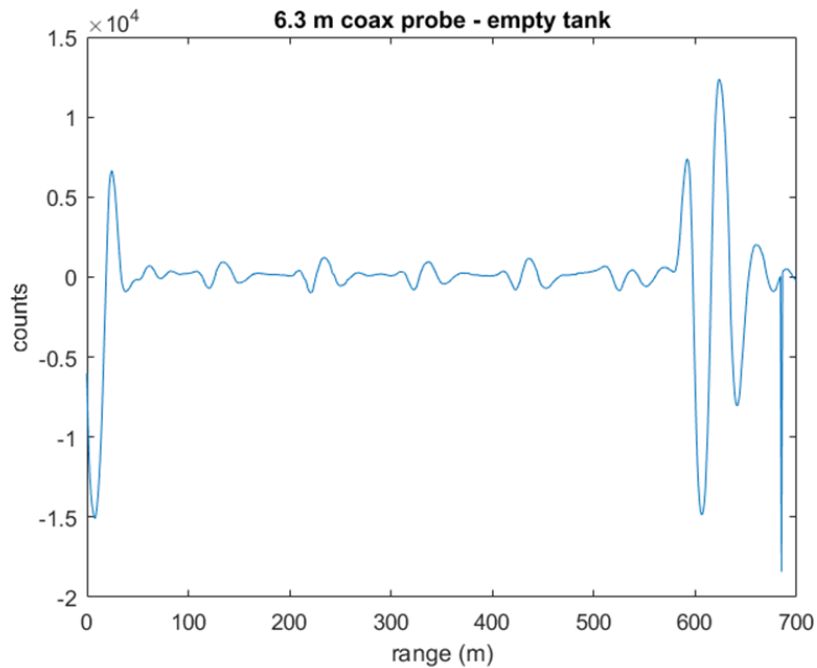

This illustrates a properly assembled coax probe with an empty tank. The spacers are visible on the probe every meter but their heights are small (<1000 counts). The large reflection at 6 m is the end of the probe.

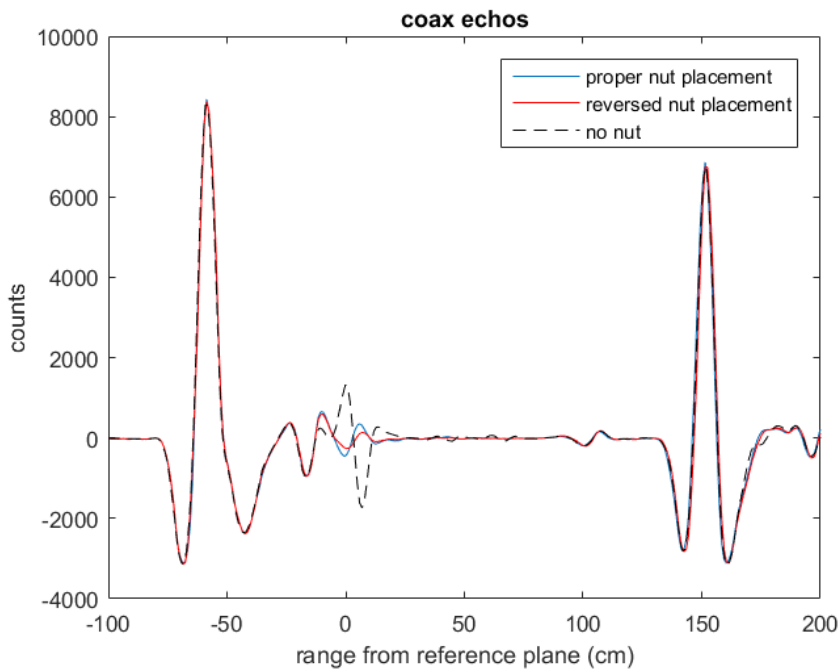

This illustrates the importance of proper nut placement. The biggest effect is from a nut missing altogether

7 Parts List

7.1 Overview

Individually saleable parts for the various Transmitter models are listed in this section.

Table 7-1: Parts

Part number	Description
50096657-502	Integrally Mounted Advanced Indicator Kit (Programmed for Level)
50095191-502	Terminal Module w/Lightning Protection Kit for HART
50095191-510	Terminal Module w/Lightning Protection Kit for FOUNDATION Fieldbus
50095191-501	Terminal Module w/o Lightning Protection for HART
50095191-509	Terminal Module w/o Lightning Protection for FOUNDATION Fieldbus
50096656-501	HART Electronics Module Kit (Programmed for Level)
50096656-502	HART Electronics Module Kit w/connection for external configuration buttons (Programmed for Level)
50096656-503	FOUNDATION Fieldbus Electronics Module Kit (Programmed for Level)
50096656-504	FOUNDATION Fieldbus Electronics Module Kit w/connection for external configuration buttons (Programmed for Level)
50096711-501	Spare sensor Housing (including the sensor electronics)
50135319-501	GWR Level Saturated Steam Application 0.3 m Reference and Licence
50135319-502	GWR Level Saturated Steam Application 0.5 m Reference and Licence
50135320-501	GWR Level Interface Application Licence
50135321-501	GWR Level Low-DC Application Licence

8 Glossary

Accuracy: The closeness of the agreement between the result of the measurement and the conventional true value of the quantity. Accuracy should not be confused with precision. The quoted accuracy depends on the initial characterization, the reproducibility of the standard, and the stability of the measurement between calibrations. The actual accuracy also depends on the equipment performing and being operated to specification.

Application and Validation Tool (AVT): The online tool which allows users to input technical data about a specific process tank and to validate that the correct level transmitter application is delivered to the site ready to install.

ATEX Directive: Consists of two European Union directives which describe the acceptable equipment and work environment permitted in an environment with an explosive atmosphere.

Blocking Distance: A zone where measurements are not performed.

Burnout: Transmitter burnout status indicates a critical sensor failure has occurred. In a HART transmitter, burnout status can be configured to set the analog output to $\leq 3.6\text{mA}$ (downscale) or $\geq 21.0\text{mA}$ (upscale).

Canadian Standards Association (CSA): A not-for-profit standards organization which develops standards. The CSA registered mark shows that a product has been independently tested and certified to meet recognized standards for safety or performance.

Cyclic Redundancy Check (CRC): An error-detecting code commonly used in digital networks and storage devices to detect accidental changes to raw data.

Damping: Applies digital filtering to suppress noise effects on the PV. The range is from 0.0 to 60.0 seconds.

Digital to Analog Convertor (DAC): A function that converts digital data (usually binary) into an analog signal (current, voltage).

Device Description (DD): Files describing the configuration of a transmitter for use by handheld or PC applications.

Device Type Manager (DTM): A Device Type Manager is part of the Field Device Tool (FDT) standard, and is a software component for a device that contains the device-specific data, functions and logic elements.

Dielectric constant (DC): The ratio of the conductivity of a material to that of a vacuum. In level measurement, a high DC indicates a non-conductive or insulating material

Equivalent-Time Sampling (ETS): Is a method of increasing the effective sampling rate. ETS constructs a repetitive signal by capturing small parts of the waveform from successive triggered acquisitions. This enables the accurate capture of signals whose frequency components are much higher than the maximum sample rate.

Factory Mutual (FM): Provides third-party certification and approval of commercial and industrial products, including Hazardous Location Electrical Equipment.

Field Device Tool (FDT): A general purpose application / tool that allows users to manage many DTMs running their individual transmitters.

Flooded Interface measurement: There is no air layer in the tank, there is only fluid from the process connector` to the interface.

FOUNDATION™ Fieldbus (FF): An all-digital, serial, bi-directional communications network in a plant or factory automation environment. It is an open architecture, developed and administered by the Fieldbus FOUNDATION.

Guided Wave Radar (GWR): A method commonly used to measure levels of liquid and solid materials. Low frequency microwave pulses are guided by a metal probe and reflected off a surface to determine levels in tanks.

HART® Communications Protocol: Highway Addressable Remote Transducer (HART) is a digital industrial automation protocol that is modulated over legacy 4-20 mA analog instrumentation wiring

Honeywell Experion: An advanced distributed control system (DCS) and innovative software applications to improve users' business performance and ensures reliable performance.

Honeywell Field Device Manager (FDM): A centralized asset management system for remote configuration and maintenance of smart field devices based on HART, PROFIBUS and Fieldbus FOUNDATION protocols.

Interface Measurement: Level measurements where two liquids meet. For example, an oil layer on top of water. Where the two meet is referred to as the interface level.

International Electrotechnical Commission Explosive Scheme (IECEx): IECEx certification provides assurance that the strictest safety requirements of IEC International Standards are met. Designed to facilitate the international trade of electrical equipment used in explosive, hazardous environments.

Latching Mode: A parameter in the Level transmitter Advanced Display which allows for the selection of the behavior of the Level transmitter in the event of a critical error. In this mode, the transmitter will stay in the critical error state until a user performs a hardware or software reset.

Lower Range Value (LRV): A Basic configuration parameter which allows users to enter the measuring value for which the analog output will be scaled to 4 mA.

Lower Product: The heavier liquid when two liquids exist in a vessel (e.g. water in an oil/water measurement application).

Maintenance Mode: A mode that the transmitter supports to communicate to external systems that it is not available for process measurement.

NAMUR NE 43: NAMUR is an international association of process instrumentation user companies. NE 43 is a NAMUR recommendation to promote a standardization of the 4-20mA signal level for failure information. Normal 2-wire transmitters use the 3.8 to 20.5mA signal range for measurement information, with ≥ 21 mA or ≤ 3.6 mA to indicate diagnostic failures.

National Pipe Thread (NPT): A U.S. standard for tapered threads used on threaded pipes and fittings.

Echo Lost Timeout: This parameter allows adjustment of the time that the GWR Transmitter waits after echo loss before producing a critical fault alarm.

Latching Mode: This parameter allows the selection of the behavior of the GWR transmitter in the case of a critical error. If the Latching option is selected, the GWR transmitter will stay in the critical error state until a user performs a hardware or software reset. This parameter is only relevant to HART transmitters.

Operating Range: The range of conditions in which the transmitter is designed to operate.

PACTWare: A software application for instruments that is based on FDT technology. It can be used to load and run a manufacturer's DTM for a specific instrument.

Precision: The closeness of agreement between the results obtained by applying a measurement procedure several times on identical materials and under prescribed measurement conditions. The smaller the random part of experimental error, the more precise the measurement procedure.

Printed Wiring Assembly (PWA): Also known as a printed circuit assembly. It is a populated electronics board.

Process Variable (PV): A dynamic feature of the process which may change rapidly and is measured. The PV is the only dynamic variable sent via analog signal, in HART transmitters, to the control system.

Quaternary Variable (QV): The fourth dynamic feature of the process which may change rapidly and is measured. (HART only)

Random Access Memory (RAM): A type of computer data storage. Data is accessed randomly where any byte of memory can be accessed without touching the preceding byte.

Reproducibility: The closeness of agreement between independent results obtained in the normal and correct operation of the same method on identical test material, in a short space of time, and under the same test conditions (such as the same operator, same apparatus, same laboratory).

Safe Failure Fraction (SFF): The fraction of the overall failure rate of a device that results in either a safe fault or a diagnosed unsafe fault.

Safety Instrumented Function (SIF): A set of equipment intended to reduce the risk due to a specific hazard (a safety loop).

Safety Integrity Level (SIL): A discrete level (one out of a possible four) for specifying the safety integrity requirements of the safety functions to be allocated to the E/E/PE safety-related systems where Safety Integrity Level 4 has the highest level of safety integrity and Safety Integrity Level 1 has the lowest.

Safety Instrumented System (SIS): The implementation of one or more Safety Instrumented Functions and is composed of any combination of sensor(s), logic solver(s), and final element(s).

Secondary Variable (SV): A secondary dynamic feature of the process which may change rapidly and is measured. (HART only)

Stillwell / Stilling well: A chamber that enables level measurement in turbulent conditions.

Tertiary Variable (TV): A tertiary dynamic feature of the process which may change rapidly and is measured. (HART only)

Time-Domain Reflectometry (TDR): For Level measurement, it is a measurement technique used to determine distance by measuring the time it takes to send electromagnetic measurement pulses along a probe (for example, a metallic probe), reflect off a surface (liquid or solid) and travel back to the source.

Upper Product: The lighter liquid when two liquids exist in a vessel (e.g. oil in an oil/water measurement application)

Upper Range Value (URV): A Basic configuration parameter which allows users to enter the measuring value for which the analog output will be scaled to 20 mA (HART only).

9 Appendix Certifications

9.1 Safety Instrumented Systems (SIS) Installations

For Safety Certified Installations, please refer to *SLG 700 Safety Manual*, document #34-SL-25-05 for installation procedure and system requirements.

9.2 European Directive Information (EU)

The SLG 700 Transmitter complies with the following directives.

Directive	Description
2014/30/EU	Electromagnetic Compatibility (EMC)
ATEX 2014/34/EU	Explosion Protection Regulation (where applicable)
2014/68/EU	Pressure Equipment Directive (PED)

The SLG 700 Transmitter complies with the following EMC standards

Directive	Description
EN 61326-1	General EMC requirements for Electrical equipment for measurement, control, and laboratory use
EN 61326-3-1	Functional Safety EMC requirements for Electrical equipment for measurement, control, and laboratory use
EN 55011, CISPR 16-1 and CISPR 16-2	Emissions of radio frequencies
NAMUR NE21 (HART / 4-20mA only)	Electromagnetic compatibility of industrial process and laboratory control equipment

The SLG 700 transmitter complies with the radiated immunity requirements when a coax probe is used OR with any probe when the device is installed in a metallic vessel or stillwell.

When the device is installed on an open-air tank or non-metallic tank the electromagnetic emissions levels will remain compliant with any probe, however, a coax probe is recommended if a strong electromagnetic field may be present near the probe.

A copy of the SLG 700 EU Declaration of Conformity can be downloaded here:
<https://www.honeywellprocess.com/library/support/Public/Documents/50099165.pdf>

9.3 Hazardous Locations Certifications

AGENCY	TYPE OF PROTECTION	COMM	FIELD PARAMETERS
CSA cCSAus (Canada and USA) Certificate # 70016542	Explosion Proof with intrinsically safe probe: Class I, Division 1, Groups A, B, C, D; Class I, Zone 0/1 AEx d[ia] IIC T6..T5 Ga/Gb Ex d[ia] IIC T6..T5 Ga/Gb Dust Ignition Proof: Class II, III, Division 1, Groups E, F, G; T5 or T6 Class II Zone 21 AEx tb IIIC T95 °C DIP A21/II, III /1/EFG/Ex tb IIIC T95 °C	All	Note 1
	Intrinsically Safe: Class I, II, III, Division 1, Groups A, B, C, D, E, F, G; T4 Class 1 Zone 0 AEx ia IIC T4 Ga Ex ia IIC T4 Ga Class I Zone 2 AEx ic IIC T4 Gc Ex ic IIC T4 Gc	4-20 mA / HART	Note 2a
	Non-incendive with intrinsically safe probe: Class I, Division 2, Groups A, B, C, D; T6..T5 Class I, Zone 0/2 AEx nA[ia] IIC T6..T5 Ga/Gc Ex nA[ia] IIC T6..T5 Ga/Gc	4-20 mA / HART	Note 1
	Enclosure: Type 4X/ IP66/ IP67. Dual Seal in accordance with ANSI/ISA 12.27.01	All	All
	Canadian Registration Number (CRN):	All SLG 700 models are registered in all provinces and territories in Canada.	

FM Approvals™ Certificate # FM16US0117X	Explosion proof with intrinsically safe probe: Class I Division 1, Groups A, B, C, D with Intrinsically safe probe Class 1, Zone 0/1 AEx ia/d IIC Ga/Gb T5..T6 Dust Ignition Proof with intrinsically safe probe: Class II, Division 1, Groups E, F, G, T5..T6 with Intrinsically Safe Probe Zone 21 AEx tb IIIC Db T95 °C Probe : Zone 20 AEx ia IIIC Da T95 °C	All	Note 1
	Intrinsically Safe: Class I, II, III, Division 1, Groups A, B, C, D, E, F, G, T4 Class I, Zone 0, AEx ia IIC T4 Ga Class I, Zone 2, AEx ic IIC T4 Gc	4-20 mA / HART	Note 2
		FOUNDATION Fieldbus / FISCO	Note 2
	Non-incendive with intrinsically safe probe: Class I, II, III, Division 2, Groups A, B, C, D, F, G, T5..T6 with Intrinsically Safe Probe Class I, Zone 2, AEx nA IIC T5..T6 Gc Class I, Zone 2[0], AEx nA[ja Ga] IIC T5..T6 Gc (Remote version only.)	4-20 mA / HART	Note 1
		FOUNDATION Fieldbus / FISCO	Note 1
	Enclosure: Type 4X/ IP66/ IP67. Dual Seal in accordance with ANSI/ISA 12.27.01	All	All

ATEX (EU) SIRA Certificate #s 15ATEX2004X 15ATEX4005X	Flameproof with IS probe: 2[1] G Ex db [ia] IIC T6..T5 Gb[Ga] Dust Ignition Proof: II 2D Ex tb IIIC T95°C Db	All	Note 1
	Intrinsically Safe: II 1 G Ex ia IIC T4 Ga II 3[1] G Ex ic [ia] IIC T4 Gc[Ga]	4-20 mA / HART	Note 2a
		FOUNDATION Fieldbus / FISCO	Note 2b/2c
	Non-incendive with IS probe: 3[1] G Ex nA[ia] IIC T6..T5 Gc[Ga]	4-20 mA / HART	Note 1
		FOUNDATION Fieldbus / FISCO	Note 1
Enclosure: IP66/ IP67	All	All	
IECEX (World) Certificate # SIR 15.0005X	Flameproof with IS probe: Ex db[ia] IIC T6..T5 Gb[Ga] Dust Ignition Proof: Ex tb IIIC Db T95°C	All	Note 1
	Intrinsically Safe: Ex ia IIC T4 Ga Ex ic [ia] IIC T4 Gc[Ga]	4-20 mA / HART	Note 2a
		FOUNDATION Fieldbus / FISCO	Note 2b/2c
	Non-incendive with IS probe: Ex nA[ia] IIC T6..T5 Gc[Ga]	4-20 mA / HART	Note 1
		FOUNDATION Fieldbus / FISCO	Note 1
Enclosure: IP66/ IP67	All	All	
CCoE (India) CCEs# P358814/1 SAEx (South Africa) Certificate # S-XPL/ 15.0528X KOSHA (Korea) Certificate #s 16-AV4BO-0093X 16-AV4BO-0094X 16-AV4BO-0095X 16-AV4BO-0161X 16-AV4BO-0165X 16-AV4BO-0167X	Flameproof with IS probe: Ex d[ia] IIC T4 Gb[Ga] Dust Ignition Proof: Ex tb IIIC T95°C Ex tD A21 T95°C (KOSHA)	All	Note 1
	Intrinsically Safe: Ex ia IIC T4 Ga	4-20 mA / HART	Note 2a
		FOUNDATION Fieldbus	Note 2b
	Non-incendive with IS probe: Ex nA[ia] IIC T4 Gc[Ga]	4-20 mA / HART	Note 1
		FOUNDATION Fieldbus	Note 1
Enclosure: IP66/ IP67	All	All	

<p>NEPSI (China)</p> <p>Certificate # GYJ16.1279X</p>	<p>Flameproof with IS probe: Ex d ia IIC T4 Ga/Gb</p> <p>Dust Ignition Proof: Ex tb IIIC T95°C</p>	All	Note 1
	<p>Intrinsically Safe: Ex ia IIC T4 Ga</p>	4-20 mA / HART	Note 2a
		FOUNDATION Fieldbus	Note 2b
	<p>Non-incendive with IS probe: Ex nA ia IIC T4 Ga/Gc</p>	4-20 mA / HART	Note 1
		FOUNDATION Fieldbus	Note 1
<p>Enclosure: IP 66/67</p>	All	All	
<p>INMETRO (Brazil)</p> <p>Certificate # IEx 16.0072X</p>	<p>Flameproof with IS probe: Ex d[ia Ga] IIC T4 Gb</p> <p>Dust Ignition Proof: Ex tb IIIC T95°C Db</p>	All	Note 1
	<p>Intrinsically Safe: Ex ia IIC T4 Ga</p>	4-20 mA / HART	Note 2a
		FOUNDATION Fieldbus	Note 2b
	<p>Non-incendive with IS probe: Ex nA[ia Ga] IIC T4 Gc</p>	4-20 mA / HART	Note 1
		FOUNDATION Fieldbus	Note 1
<p>Enclosure: IP 66/67</p>	All	All	
<p>EAC TR-CU (Russia)</p> <p>Certificate # TC RU C-US. ГБ08.B.01747</p>	<p>Flameproof with IS probe: 1 Ex db [ia] IIC T4 X</p> <p>Dust Ignition Proof: Ex tb IIIC T95°C X</p>	All	Note 1
	<p>Intrinsically Safe: 0 Ex ia IIC T4 X</p>	4-20 mA / HART	Note 2a
		FOUNDATION Fieldbus	Note 2b
	<p>Non-incendive with IS probe: 2 Ex nAc[ia] IIC T4 X</p>	4-20 mA / HART	Note 1
		FOUNDATION Fieldbus	Note 1
<p>Enclosure: IP 66/67</p>	All	All	

Notes:

1. Non-Intrinsically Safe Operating Voltages:

Voltage at terminals = 14.0 to 42.0 Vdc (HART / 4-20mA)
 = 9.0 to 32.0 Vdc (FOUNDATION Fieldbus)

2. Intrinsically Safe Entity Parameters

a. Analog/ HART ia Entity Values:

$V_{max} = U_i = 30 \text{ V}$ $I_{max} = I_i = 225 \text{ mA}$ $C_i = 4 \text{ nF}$ $L_i = 0$ $P_i = 1.1 \text{ W}$

b. FOUNDATION Fieldbus- ia Entity Values

$V_{max} = U_i = 30 \text{ V}$ $I_{max} = I_i = 225 \text{ mA}$ $C_i = 0 \text{ nF}$ $L_i = 0$ $P_i = 1.1 \text{ W}$

c. FOUNDATION Fieldbus (FISCO)- Entity Values

$V_{max} = U_i = 17.5 \text{ V}$ $I_{max} = I_i = 380 \text{ mA}$ $C_i = 0 \text{ nF}$ $L_i = 0$ $P_i = 5.32 \text{ W}$

When Installed as FISCO $T_a = -50\text{C}$ to 45C

For ic entity, refer to the control drawing 50098941

3. For ambient and process temperature ranges and temperature classification, see section 9.5

Overfill Protection	WHG Certificate #: Z-65.16-556. TÜV-tested and approved for overfill protection according to the German WHG regulations
SIL 2/3 Certification	IEC 61508 SIL 2 for non-redundant use and SIL 3 for redundant use according to EXIDA and TÜV Nord Sys Tec GmbH & Co. KG under the following standards: IEC61508-1: 2010; IEC 61508-2: 2010; IEC61508-3: 2010. Note: Only transmitters with SIL markings are certified for SIL applications. – Transmitters ordered with SIL certification will signify the SIL Level on the SLG 700 Nameplate.
China Pattern Approval	The SLG 700 is approved according to the Law on Metrology of the People's Republic of China. China Pattern Approval identification numbers 2016-L262, 2016-L263, and 2016-L264.
Korean KC MSIP Registration	SLG700 transmitters are registered under the clause 3, Article 58-2 of Radio Waves Act. Registration # MSIP-REI-Ssi-SLG720

9.4 Marking ATEX Directive

General

The following information is provided as part of the labeling of the transmitter:

- Manufacturer name and location
- Notified Body identification: SIRA
- For complete model number, see the Model Selection Guide for the level transmitter.
- The serial number of the transmitter is located on the top nameplate. The first five digits of the serial number, yyWww, indicate the year and week of manufacture using the last two digits of the year (yy), the week identifier "W", and the two digit week number (ww), in that order. For example, 17W42 indicates the date of manufacture is the 42nd week of 2017.

Apparatus Marked with Multiple Types of Protection

The user must determine the type of protection required for installation of the equipment. The user shall then check the box adjacent to the type of protection used on the equipment certification nameplate. Once a type of protection has been checked on the nameplate, the equipment will not be reinstalled using any of the other certification types.

9.5 Conditions of Use for Ex Equipment, “Hazardous Location Equipment” or "Schedule of Limitations"

Consult the manufacturer for dimensional information on the flameproof joints for repair.

Painted surface of the SLG transmitter may store electrostatic charge and become a source of ignition in applications with relative humidity less than 30% where the painted surface is relatively free of surface contamination such as dirt, dust or oil. Cleaning of the painted surface should only be done with a damp cloth.

Flame-proof Installations: The Transmitter can installed in the boundary wall between an area of EPL Ga/ Class I Zone 0/ Category 1 and the less hazardous area, EPL Gb/ Class I Zone 1/ Category 2. In this configuration, the process connection is installed in EPL Ga/ Class I Zone 0/ Category 1, while the transmitter housing is located in EPL Gb/ Class I Zone 1/ Category 2.

Intrinsically Safe: Must be installed per drawing 50098941. See Control Drawing.

Division 2: This equipment is suitable for use in a Class I, Division 2, Groups A, B, C, D; T4 or Non-Hazardous Locations Only.

The enclosure is manufactured from low copper aluminum alloy. In rare cases, ignition sources due to impact and friction sparks could occur. This shall be considered during Installation, particularly if equipment is installed a Zone 0 location.

If a charge-generating mechanism is present, the exposed metallic part on the enclosure is capable of storing a level of electrostatic that could become incendive for IIC gases. Therefore, the user/ installer shall implement precautions to prevent the buildup of electrostatic charge, i.e. earthing the metallic part. This is particularly important if equipment is installed a Zone 0 location.

For FM approved transmitters, the Zone 2 installation with probe in Zone 0 is allowed for the remote version only.

Maximum Power Supply Source Voltage Um

The maximum voltage (Um) for the non-intrinsically safe circuits is 250VAC 47Hz-63Hz or 250VDC.

Warnings and cautions

Intrinsically Safe and Non-Incendive Equipment	WARNING: SUBSTITUTION OF COMPONENTS MAY IMPAIR SUITABILITY FOR USE IN HAZARDOUS LOCATIONS.
Explosion-Proof/ Flameproof	WARNING: DO NOT OPEN WHEN AN EXPLOSIVE ATMOSPHERE MAY BE PRESENT
Non-Incendive Equipment	WARNING: DO NOT OPEN WHEN AN EXPLOSIVE ATMOSPHERE MAYBE PRESENT
All Protective Measures:	WARNING: FOR CONNECTION IN AMBIENTS ABOVE 60°C USE WIRE RATED 105°C

Ambient and Process Temperature Ranges

The ambient temperature range (Ta), maximum process temperature, and applicable temperature class of the equipment is as follows:

SLG720			
Protection Type	Ta, Ambient Temperature Range	Maximum Process Temperature	Temperature Class
Intrinsic Safety	-50°C to +70°C	150°C	T4
Intrinsic Safety	-50°C to +60°C	200°C	T4
other protection types	-50°C to +85°C	150°C	T5
other protection types	-50°C to +70°C	150°C	T6
other protection types	-50°C to +60°C	200°C	T6

SLG726			
Protection Type	Ta, Ambient Temperature Range	Maximum Process Temperature	Temperature Class
Intrinsic Safety	-50°C to +70°C	300°C	T4
Intrinsic Safety	-50°C to +60°C	450°C	T4
other protection types	-50°C to +85°C	300°C	T5
other protection types	-50°C to +70°C	300°C	T6
other protection types	-50°C to +60°C	450°C	T6

All models when installed as FISCO Ta= -50°C to 45°C
 Operating range is always limited to -40°C for all transmitters.

Models with CCoE, SAEx, KOSHA, NEPSI, INMETRO, or EAC TR-CU nameplate are limited to temperature class T4 for all ambient and process temperature ranges. At the time of writing, only CSA, FM, IECEx, and ATEX models have been certified with the temperature classes T5 or T6 as specified in the table above.

9.6 Control Drawing

COPYRIGHT 2014, HONEYWELL INTERNATIONAL INC. NEITHER THIS DOCUMENT NOR THE INFORMATION CONTAINED HEREIN SHALL BE REPRODUCED, USED OR DISCLOSED TO OTHERS WITHOUT THE WRITTEN AUTHORIZATION OF HONEYWELL. USE, DUPLICATION, OR DISCLOSURE OF THIS DOCUMENT IS SUBJECT TO THE RESTRICTIONS SET FORTH IN A WRITTEN AGREEMENT. NOTHING CONTAINED HEREIN SHALL BE CONSTRUED AS CONFERRING BY IMPLICATION, ESTOPPEL, OR OTHERWISE ANY LICENSE TO ANY PATENT, TRADEMARK, COPYRIGHT OR OTHER INTELLECTUAL PROPERTY RIGHT OF HONEYWELL OR ANY THIRD PARTY.				PRE REL					
				ISS	REVISION & DATE				APPD
				B	07/18/2017 ECN 2017-2275				VM

SLG Series Guided Wave Radar (GWR) Level Transmitter, ANALOG, HART, FF/ PROFIBUS Communications

1. Intrinsically safe installation shall be in accordance with
 - a. FM (USA): ANSI/NFPA 70, NEC[®] Articles 504 and 505.
 - b. CSA (Canada): Canadian Electrical Code (CEC), part I, section 18.
 - c. ATEX: Requirements of EN 60079-14, 12.3 (See also 5.2.4).
 - d. IECEx: Requirements of IEC 60079-14, 12.3 (See also 5.2.4).
2. ENTITY approved equipment shall be installed in accordance with the manufacturer's Intrinsic Safety Control Drawing.
3. The Intrinsic Safety ENTITY concept allows the interconnection of two ENTITY Approved Intrinsically safe devices with ENTITY parameters not specifically examined in combination as a system when:

$U_o, V_o, \text{ or } V_t \leq U_i \text{ or } V_{max}; I_o, I_{sc}, \text{ or } I_t \leq I_i \text{ or } I_{max}; C_a \text{ or } C_o \geq C_i + C_{cable}, L_a \text{ or } L_o \geq L_i + L_{cable}, P_o \leq P_i.$

Where two separate barrier channels are required, one dual-channel or two single-channel barriers may be used, where in either case, both channels have been Certified for use together with combined entity parameters that meet the above equations.
4. System Entity Parameters:

SLG Transmitter: $V_{max} V_o \text{ or } U_o, I_{max} I_{sc} \text{ or } I_o;$

SLG Transmitter: $C_i + C_{cable} \leq \text{Control Apparatus } C_a,$

SLG Transmitter: $L_i + L_{cable} \leq \text{Control Apparatus } L_a.$
5. When the electrical parameters of the cable are unknown, the following values may be used:

Capacitance: 197pF/m (60 pF/ft) Inductance: 0.66μH/m (0.020μH/ft).
6. Control equipment that is connected to Associated Equipment must not use or generate more than 250V 47-63Hz AC or 250V DC.
7. Associated equipment must be FM, CSA ATEX or IECEx (depending on location) listed. Associated equipment may be installed in a Class I, Division 2 or Zone 2 Hazardous (Classified) location if so approved.
8. Non-Galvanically isolated equipment (grounded Zener Barriers) must be connected to a suitable ground electrode per:
 - a. FM (USA): NFPA 70, Article 504 and 505. The resistance of the ground path must be less than 1.0 ohm.
 - b. CSA (Canada): Canadian Electrical Code (CEC), part I, section 10.
 - c. ATEX: Requirements of EN 60079-14, 12.2.4.
 - d. IECEx: Requirements of IEC 60079-14, 12.2.4.
9. Intrinsically Safe DIVISION 1/ Zone 0 WARNING: SUBSTITUTION OF COMPONENTS MAY IMPAIR SUITABILITY FOR USE IN HAZARDOUS LOCATIONS.
10. Division 2/ Zone 2: WARNING: DO NOT OPEN WHEN AN EXPLOSIVE GAS ATMOSPHERE IS PRESENT.
11. NO REVISION OF THIS CONTROL DRAWING IS PERMITTED WITHOUT AUTHORIZATION FROM THE AGENCIES listed.
12. For release approvals see ECO-0117771.

MASTER FILE TYPE: MS WORD	DRAWN	VM	02/03/15	<h2 style="margin: 0;">Honeywell</h2>		
	CHECKED	MJW	02/03/15	<p style="margin: 0;">CONTROL DRAWING</p> <p style="margin: 0;">SLG SERIES LEVEL TRANSMITTER</p> <p style="margin: 0;">DIVISIONS 1 & 2 / ZONE 0 & 2</p>		
	DEV ENG					
	MFG ENG					
	QA ENG					
	TOLERANCE UNLESS NOTED				A /A4	<h1 style="margin: 0;">50098941</h1>
ANGULAR DIMENSION				SCALE: None	USED ON	SH. 1 OF 4

HART

ia PARAMETERS for Div 1 and Zone 0		ic PARAMETERS for Div 2 and Zone 2	
ia ENTITY PARAMETERS	Associated Apparatus for ia	ic ENTITY PARAMETERS	Associated Apparatus for ic
U_i or $V_{max} \leq 30V$	U_o, V_{oc} or $V_t \leq 30V$	U_i or $V_{max} \leq 42V$	U_o, V_{oc} or $V_t \leq 42V$
I_i or $I_{max} \leq 225$ mA	I_o (I_{sc} or I_t) ≤ 225 mA	I_i or $I_{max} \leq 337$ mA	I_o (I_{sc} or I_t) ≤ 337 mA
P_i or $P_{max} = 1.1W$	$P_o \leq 1.1W$	P_i or $P_{max} = 1.1W$	$P_o \leq 1.1W$
$C_i = 4$ nF	C_a or $C_o \geq C_{cable} + C_{str}$	$C_i = 4$ nF	C_a or $C_o \geq C_{cable} + C_{str}$
$L_i = 0$ μH	L_a or $L_o \geq L_{cable} + L_{str}$	$L_i = 0$ μH	L_a or $L_o \geq L_{cable} + L_{str}$

NON-HAZARDOUS LOCATION

HAZARDOUS (CLASSIFIED) LOCATION

CLASS I, DIVISION 1, GROUPS A, B, C, D, E, F & G;
 ZONE 0 IIC & ZONE 2 IIC,
 CLASS I DIVISION 2, GROUPS A, B, C, D;

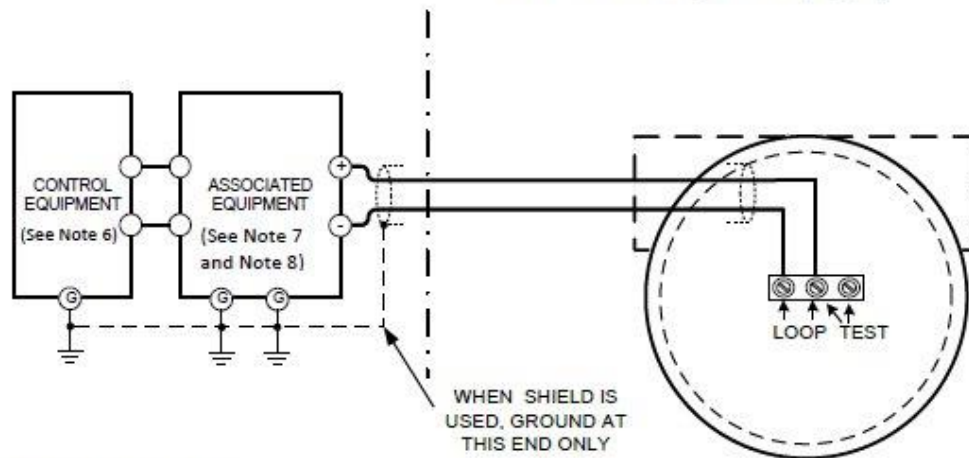

ASSOCIATED EQUIPMENT NOT REQUIRED
 FOR DIV 2 / ZONE 2 INSTALLATIONS

Honeywell

A/A4

50098941

SCALE: None

REV B

DATE 07/18/2017

SH. 2 of 4

FOUNDATION FIELDBUS

ia PARAMETERS for Div 1 and Zone 0		ic PARAMETERS for Div 2 and Zone 2	
ia ENTITY PARAMETERS	Associated Apparatus for ia	ic ENTITY PARAMETERS	Associated Apparatus for ic
U_i or $V_{max} \leq 30V$	U_o, V_{oc} or $V_t \leq 30V$	U_i or $V_{max} \leq 32V$	U_o, V_{oc} or $V_t \leq 32V$
I_i or $I_{max} \leq 225$ mA	I_o (I_{sc} or I_t) ≤ 225 mA	I_i or $I_{max} \leq 337$ mA	I_o (I_{sc} or I_t) ≤ 337 mA
P_i or $P_{max} = 1.1W$	$P_o \leq 1.1$ W	P_i or $P_{max} = 1.1W$	$P_o \leq 1.1$ W
$C_i = 0$ nF	C_a or $C_o \geq C_{cable} + C_{SLG}$	$C_i = 0$ nF	C_a or $C_o \geq C_{cable} + C_{SLG}$
$L_i = 0$ μ H	L_a or $L_o \geq L_{cable} + L_{SLG}$	$L_i = 0$ μ H	L_a or $L_o \geq L_{cable} + L_{SLG}$

FIELDBUS INTRINSICALLY SAFE CONCEPT (FISCO)

ENTITY PARAMETERS	Associated Apparatus
U_i or $V_{max} \leq 17.5$	U_o, V_{oc} or $V_t \leq 18V$
I_i or $I_{max} \leq 380$ mA	I_o (I_{sc} or I_t) ≤ 380 mA
P_i or $P_{max} = 5.32W$	$P_o \leq 5.32$ W
$C_i = 0$ nF	C_a or $C_o \geq C_{cable} + C_{SLG}$
$L_i = 0$ μ H	L_a or $L_o \geq L_{cable} + L_{SLG}$

NON-HAZARDOUS LOCATION

HAZARDOUS (CLASSIFIED) LOCATION

CLASS I, CLASS II, DIVISION 1, GROUPS A, B, C, D, E, F & G;
 ZONE 0 IIC & ZONE 2 IIC,
 CLASS I DIVISION 2, GROUPS A, B, C, D;

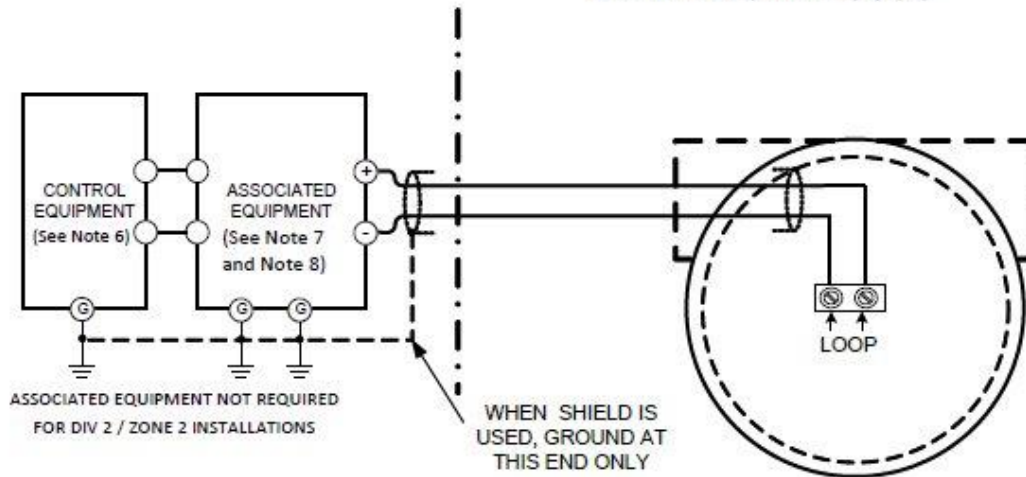

Honeywell

A/A4

50098941

SCALE: None

REV B

DATE 07/18/2017

SH. 3 of 4

CUSTOMER SUPPLIED PROBES

SLG transmitter models SLG7xx-000 are not supplied with a measurement probe. These transmitters must be installed using a probe as per the following information. Attaching any other probe or device may impair suitability for use in hazardous locations. A solid metal probe or a flexible wire probe may be used.

Solid Metal Probes:

A solid metal probe may be installed if it is constructed of:
STAINLESS STEEL PER ASTM A-276, TYPE 316L, CONDITION A
OR
ASTM B574 ALLOY UNS N10276 SOLUTION ANNEALED

Solid metal probes must be a MAXIMUM of 16mm diameter AND a MAXIMUM of 6.3m long

Flexible Wire Probes:

A flexible wire probe may be installed if it is constructed of:
A swage stud constructed of STAINLESS STEEL PER ASTM A-276, TYPE 316L, CONDITION A
AND the flexible rope is constructed of:
ANSI T316 Stainless Steel

Flexible wire probes must be a MAXIMUM of 6mm diameter AND a MAXIMUM of 75m long

Attaching Probe:

Fully thread the nut onto the central conductor. Using a lock washer, thread the wire swage on to the central conductor. Torque the nut against probe and lock washer to secure the connection.

Tighten the wire stud and nut to the following torque:

- SLG720 6.0 Nm (4.4 ft-lbs)
- SLG726 15 Nm (11 ft-lbs)

Loctite Activator 7649 primer, and Loctite 545 thread sealant may be used and is recommended on the threads prior to installation.

Honeywell	A/A4	50098941		
		SCALE: None	REV B	DATE 07/18/2017

9.7 China RoHS

China RoHS compliance information can be downloaded here:

<https://www.honeywellprocess.com/library/support/Public/Documents/50131303.pdf>

10 Security

10.1 How to report a security vulnerability

For the purpose of submission, a security vulnerability is defined as a software defect or weakness that can be exploited to reduce the operational or security capabilities of the software or device.

Honeywell investigates all reports of security vulnerabilities affecting Honeywell products and services.

To report potential security vulnerability against any Honeywell product, please follow the instructions at:

<https://honeywell.com/pages/vulnerabilityreporting.aspx>

Submit the requested information to Honeywell using one of the following methods:

Send an email to security@honeywell.com.

or

Contact your local Honeywell Process Solutions Customer Contact Centre (CCC) or Honeywell Technical Assistance Centre (TAC) listed in the “Support and Contact information” section of this document.

Index

<p style="text-align: center;">A</p> <p>About This Manual..... iii</p> <p>Advanced Config sub-menu109</p> <p>Advanced Display Menus.....101</p> <p style="text-align: center;">B</p> <p>Basic Configuration sub-menu105</p> <p style="text-align: center;">C</p> <p>Certifications.....165</p> <p style="padding-left: 20px;">Conditions of Use for Ex Equipment172</p> <p style="padding-left: 20px;">Control Drawing174</p> <p style="padding-left: 20px;">European Directive Information (EU).....165</p> <p style="padding-left: 20px;">Hazardous Locations Certifications166</p> <p style="padding-left: 20px;">Marking ATEX Directive.....171</p> <p style="padding-left: 20px;">Safety Instrumented Systems (SIS) Installations165</p> <p>Changing the Default Failsafe Direction.....123</p> <p style="padding-left: 20px;">Failsafe Operation123</p> <p>Coaxial Probe mis-assembly157</p> <p>Communicating with the Transmitter.....6</p> <p>Copyrights, Notices and Trademarks ii</p> <p>Correlation Model Recalculation102</p> <p style="text-align: center;">D</p> <p>Diagnostics.....154</p> <p>Advanced Display Menus109, 114</p> <p>DTM and DD – HART and FF.....96</p> <p>DTM-based tools and Experion.....9</p> <p style="text-align: center;">E</p> <p>Electrical Installation.....95</p> <p style="padding-left: 20px;">Explosion-Proof Conduit Seal.....95</p> <p style="padding-left: 20px;">Lightning Protection.....95</p> <p style="padding-left: 20px;">Process Sealing.....95</p> <p style="padding-left: 20px;">Supply Voltage Limiting Requirements95</p> <p style="padding-left: 20px;">Terminal Connections93</p> <p style="padding-left: 20px;">Wiring Procedure94</p> <p>Electronics Housing.....2</p> <p>Error Messages154</p> <p>European Directive Information (EU)165</p> <p style="text-align: center;">F</p> <p>Flange mount.....78</p> <p>Flange pressure ratings.....90</p> <p>FOUNDATION Fieldbus8</p>	<p style="text-align: center;">G</p> <p>Glossary..... 162</p> <p style="text-align: center;">H</p> <p>HART..... 6</p> <p>Hazardous Locations Certifications 166</p> <p style="text-align: center;">I</p> <p>Install conduit entry plugs and adapters..... 89</p> <p>Introduction 1</p> <p style="text-align: center;">M</p> <p>Maintenance 126</p> <p>Material Exposed to Tank Atmosphere 90</p> <p>Mechanical Installation</p> <p style="padding-left: 20px;">Accuracy and measuring range specifications..... 38</p> <p>Mechanical Installation 38</p> <p>Mechanical Installation</p> <p style="padding-left: 20px;">Attach/assemble the probe..... 48</p> <p>Mechanical Installation</p> <p style="padding-left: 20px;">No probe option 61</p> <p>Mechanical Installation</p> <p style="padding-left: 20px;">Attach Centering Disks 61</p> <p>Mechanical Installation</p> <p style="padding-left: 20px;">Mounting the transmitter 67</p> <p>Mechanical Installation</p> <p style="padding-left: 20px;">Suitable mounting position 73</p> <p>Mechanical Installation</p> <p style="padding-left: 20px;">Optimum Operating Temperature 74</p> <p>Mechanical Installation</p> <p style="padding-left: 20px;">Temperature requirements.....<i>See</i></p> <p>Monitor sub-menu 114</p> <p>Monitoring the Advanced Displays 120</p> <p>Mounting on a bypass / bridle 82</p> <p>Mounting on a non-metallic container<i>See</i></p> <p style="text-align: center;">N</p> <p>Nozzle mount 79</p>
--	---

O

Operating the Transmitter	96
Advanced Display Menu.....	101
Data Entry	99
Menu Navigation.....	99
Three-Button Operation.....	97
Operation	
Changing the Default Failsafe Direction.....	123
Optimum Operating Temperature.....	74
Overview.....	1

P

Parts List.....	161
Probe.....	4
Process Connector	3

R

Radar Level Measurement.....	15
Accuracy and measurement range specifications....	22
Blocking Distance Guidance	34
Container Considerations.....	33
Interface and Flooded Measurement	17
Operation.....	See
Process Applications	28
Remote mount.....	84
Rotate transmitter housing.....	86

S

Safety	
Safety Integrity Level.....	13
Safety Certification	13
Safety Instrumented Systems (SIS) Installations.....	165
Saturated Steam Probe Installation	150
Secure the probe	86
Security	179
How to report a security vulnerability	179
Security Considerations	14
Security Considerations	14
Sensor Housing	3
Sensor Housing replacement	132
Startup	
Output Check Procedures	129
Support and Contact Information	iv
Symbol Descriptions and Definitions	v

T

Telephone and Email Contacts.....	iv
Threaded mount.....	81
Three Button Operation with no Display Installed	
Zero Adjustments	97
Three-Button Operation.....	97
Transmitter Components	1
Transmitter Installation.....	36
Mechanical Installation	38
Tools	37
Trim the probe length	See
Transmitter Models.....	1
Transmitter nameplate	11
Trimming Coaxial Probes.....	147
Troubleshooting	154
Coaxial Probe mis-assembly	157
Diagnostics	154
Error Messages.....	154

W

Wire Probe replacement.....	142
Wiring a Transmitter	
Wiring Procedure	91
Write Protect Jumpers	123

Sales and Service

For application assistance, current specifications, pricing, or name of the nearest Authorized Distributor, contact one of the offices below.

ASIA PACIFIC

Honeywell Process Solutions,
Phone: + 800 12026455 or
+44 (0) 1202645583
(TAC) hfs-tac-support@honeywell.com

Australia

Honeywell Limited
Phone: +(61) 7-3846 1255
FAX: +(61) 7-3840 6481
Toll Free 1300-36-39-36
Toll Free Fax:
1300-36-04-70

China – PRC - Shanghai

Honeywell China Inc.
Phone: (86-21) 5257-4568
Fax: (86-21) 6237-2826

Singapore

Honeywell Pte Ltd.
Phone: +(65) 6580 3278
Fax: +(65) 6445-3033

South Korea

Honeywell Korea Co Ltd
Phone: +(822) 799 6114
Fax: +(822) 792 9015

EMEA

Honeywell Process Solutions,
Phone: + 800 12026455 or
+44 (0) 1202645583

Email: (Sales)

FP-Sales-Apps@Honeywell.com

or

(TAC)

hfs-tac-support@honeywell.com

AMERICAS

Honeywell Process Solutions,
Phone: (TAC) (800) 423-9883
or (215) 641-3610
(Sales) 1-800-343-0228

Email: (Sales)

FP-Sales-Apps@Honeywell.com

or

(TAC)

hfs-tac-support@honeywell.com

Specifications are subject to change without notice.

For more information
To learn more about Smartline transmitters,
visit www.honeywellprocess.com
Or contact your Honeywell account manager

Process Solutions
Honeywell
1250 W Sam Houston Pkwy S
Houston, USA, TX 77042

Honeywell Control Systems Ltd
Honeywell House, Skimped Hill Lane
Bracknell, England, RG12 1EB

Shanghai City Centre, 100 Jungi Road
Shanghai, China 20061

www.honeywellprocess.com



Honeywell

AUTHORIZED DISTRIBUTOR

De Gidts & Feldman BV

The Netherlands

www.dgfg.nl



De Gidts & Feldman

INSTRUMENTATION & FILTRATION

Honeywell

34-SL-25-11 Rev.8
December 2017
©2017 Honeywell International Inc.