

STA800 SmartLine Absolute Pressure Specification 34-ST-03-85



Introduction

Part of the SmartLine® family of products, the STA800 and STA80L are high performance absolute pressure transmitters featuring piezoresistive sensor technology combining pressure sensing with on chip temperature compensation capabilities providing high accuracy, stability and performance over a wide range of application pressures and temperatures. The SmartLine family is also fully tested and compliant with Experion® PKS providing the highest level of compatibility assurance and integration capabilities. SmartLine easily meets the most demanding application needs for pressure measurement applications.

Best in Class Features:

- Accuracy up to 0.010 %
- Automatic temperature compensation
- Rangeability up to 100:1
- Response times as fast as 80ms
- Multiple local display capabilities
- External zero, span, & configuration capability
- Polarity insensitive electrical connections
- Comprehensive on-board diagnostic capabilities
- Integral Dual Seal design for safety based on ANSI/NFPA 70-202 and ANSI/ISA 12.27.0
- Full compliance to SIL 2/3 requirements as a standard.
- Modular design characteristics
- Available with 15 year warranty
- Plugged Impulse Line Detection Option
- Dual/Triple Calibration Option (HART & Fieldbus Only)



Figure 1 – STA800 Absolute Pressure Transmitters feature field-proven piezoresistive sensor technology

Communications/Output Options:

- 4-20mA dc
- Honeywell Digitally Enhanced (DE)
- HART® (version 7.0)
- FOUNDATION™ Fieldbus

All transmitters are available with the above listed communications protocols.

Span & Range Limits:

Model	URL mmHgA (mbarA)	LRL mmHgA (mbarA)	Min Span mm HgA (mbarA)	MAWP mmHgA (mbarA)
STA822/82L	780 (1040)	0 (0)	50 (65)	780 (1040)
Model	psia (barA)	psi (barA)	psi (barA)	psia (barA)
STA840/84L	500 (35)	0 (0)	5 (.35)	500 (35)
STA87L	3000 (210)	0 (0)	30 (2.1)	3000 (210)

Description

The SmartLine family of gauge pressure, differential pressure, and absolute pressure transmitters is designed around a high performance piezo-resistive sensor. This one sensor actually integrates multiple sensors linking process pressure measurement with on-board static pressure (DP Models) and temperature compensation measurements resulting in the best total performance available. This level of performance allows the ST 800 to replace virtually any competitive transmitter available today. (√)

Unique Indication/Display Options

The ST 800 modular design accommodates a basic alphanumeric LCD display or a unique advanced graphics LCD display with many unparalleled features.

Basic Alphanumeric LCD Display Features

- Modular (may be added or removed in the field)
- 0, 90, 180, & 270 degree position adjustments
- Configurable (HART only) and standard (Pa, KPa, MPa, KGcm², Torr, ATM, inH₂O, mH₂O, bar, mbar, inHg, inHG, FTH₂O, mmH₂O, mm HG, & psi) measurement units
- 2 Lines 16 Characters (4.13H x 1.83W mm)
- Square root output indication

Advanced Graphics LCD Display Features

- Modular (may be added or removed in the field)
- 0, 90, 180, & 270 degree position adjustments
- Standard and custom measurement units available.
- Up to eight display screens with 3 formats are possible (Large PV with Bar Graph or PV with Trend Graph)
- Configurable screen rotation timing (1 to 30 sec)
- Display Square Root capabilities may be set separately from the 4-20mA dc output signal
- Unique "Health Watch" indication provides instant visibility of diagnostics
- Multiple language capability. (EN, GE, FR, IT, SP, RU, TR, CN and JP)

Diagnostics

SmartLine transmitters all offer digitally accessible diagnostics which aid in providing advanced warning of possible failure events minimizing unplanned shutdowns, providing **lower overall operational costs**

Configuration Tools

Integral Three Button Configuration Option

Suitable for all electrical and environmental requirements, SmartLine offer the ability to configure the transmitter and display via three externally accessible buttons when either display option is selected. Zero/span capabilities are also optionally available via these buttons with or without selection of a display option.

Hand Held Configuration

SmartLine transmitters feature two-way communication and configuration capability between the operator and the transmitter. This is accomplished via Honeywell's field-rated Multiple Communication Configurator (MCT404). The MCT404 is capable of field configuring DE and HART Devices and can also be ordered for use in intrinsically safe environments. All Honeywell transmitters are designed and tested for compliance with the offered communication protocols and are designed to operate with any properly validated hand held configuration device.

Personal Computer Configuration

Honeywell's SCT 3000 Configuration Toolkit provides an easy way to configure Digitally Enhanced (DE) instruments using a personal computer as the configuration interface. Field Device Manager (FDM) Software and FDM Express are also available for managing HART & Fieldbus device configurations.

System Integration

- SmartLine communications protocols all meet the most current published standards for HART/DE/Fieldbus.
- Integration with Honeywell's Experion PKS offers the following unique advantages.
 - Transmitter messaging
 - Maintenance mode indication
 - Tamper reporting
 - FDM Plant Area Views with Health summaries
 - All ST 800 units are Experion tested to provide the highest level of compatibility assurance

Modular Design

To help contain maintenance & inventory costs, all ST 800 transmitters are modular in design supporting the user's ability to replace meter bodies, add indicators or change electronic modules without affecting overall performance or approval body certifications. Each meter body is uniquely characterized to provide in-tolerance performance over a wide range of application variations in temperature and pressure and due to the Honeywell advanced interface, electronic modules may be swapped with any electronics module without losing in-tolerance performance characteristics.

Modular Features

- Meter body replacement
- Exchange/replace electronics/comms modules*
- Add or remove integral indicators*
- Add or remove lightning protection (terminal connection)*

* Field replaceable in all electrical environments (including IS) except flameproof without violating agency approvals.

With no performance effects, Honeywell's unique modularity results in **lower inventory needs and lower overall operating costs.**

Plugged Impulse Line Detection:

STA800 models are offered with a PILD option which provides indication of a plugged impulse line or process connection. When used in conjunction with a basic or advanced display, a non-critical diagnostic indication appears on the integral display. For units without an integral display, an indication can be seen via the host or hand held device when HART Protocol is utilized.

Dual/Triple Calibration:

STA800 models are optionally offered with multiple calibrations. In lieu of a standard factory calibration, units can be supplied with 1, 2, or 3 customer specified calibrations. These calibrations are stored in the meter body and provide users with factory calibrated performance at up to three different calibrated ranges. This increases application flexibility without requiring any costly recalibration or additional inventory.

Performance Specifications

Reference Accuracy:(conformance to +/-3 Sigma)

Model	URL	LRL	Min Span	Maximum Turndown Ratio	Stability (% URL/Year for five years)	Reference Accuracy % Span ^{1,2}
STA822	780 mmHgA (1040 mbarA)	0.0 mmHgA (0.0 mbarA)	50 mmHgA (65 mbarA)	15:1	0.010	0.055/0.025%
STA840	500 psia (35 barA)	0.0 mmHgA (0.0 mbarA)	5 psia (0.35 barA)	100:1		
STA82L	780 mmHgA (1040 mbarA)	0.0 mmHgA (0.0 mbarA)	50 mmHgA (65 mbarA)	15:1	0.015	0.055%
STA84L	500 psia (35 barA)	0.0 mmHgA (0.0 mbarA)	5 psia (0.35 barA)	100:1	0.010	0.055/0.025%
STA87L	3000 psi (210 barA)	0.0 mmHgA (0.0 mbarA)	30 psia (2.1 barA)	100:1		

Zero and span may be set anywhere within the listed (URL/LRL) range limits

Accuracy at Specified Span and Temperature: (Combined Zero & Span, conformance to +/-3 Sigma)

	Model	URL	Accuracy ^{1,2} (% of Span)				Temperature Effect (% Span/50°F)		
			For Spans Below	A	B	C (see URL units)	D	E	
Standard Accuracy	STA822	780 mmHgA (1040 mbarA)	8:1	0.015	0.04	90 (120)	0.050	0.040	
	STA840	500 psia (35 barA)	25:1			20 (1.4)		0.025	0.005
	STA82L	780 mmHgA (1040 mbarA)	5:1			140 (187)	0.050	0.080	
	STA84L	500 psia (35 barA)	25:1			20 (1.4)			0.025
	STA87L	3000 psi (210 barA)	10:1			300 (35)			0.025
High Accuracy Option	STA822	780 mmHgA (1040 mbarA)	50:1	0.015	0.01	90 (120)	0.050	0.040	
	STA840	500 psia (35 barA)	16:1			20 (1.4)		0.025	0.005
	STA84L	500 psia (35 barA)	10:1			20 (1.4)	0.007		
	STA87L	3000 psi (206.8 barA)	10:1			300 (35)			
Turn Down Effect						Temp Effect			
$\pm \left[A + B \left(\frac{C}{\text{Span}} \right) \right]$ % Span						$\pm \left[D + E \left(\frac{\text{URL}}{\text{Span}} \right) \right]$ % Span per 28°C (50°F)			

Total Performance (% of Span):

$$\text{Total Performance Calculation: } = \pm \sqrt{(\text{Accuracy})^2 + (\text{Temperature Effect})^2}$$

Standard Accuracy Total Performance Examples (for comparison): @ 5:1 Turndown, +/-50 °F (28°C) shift

STA822 @ 156 mmHgA: 0.256% of span

STA82L @ 156 mmHgA: 0.451% of span

STA840 @ 100 psia: 0.074% of span

STA84L @ 100 psia: 0.081% of span

STA87L @ 600 psia: 0.081% of span

Typical Calibration Frequency:

Calibration verification is recommended every four (4) years

Notes:

1. Terminal Based Accuracy - Includes combined effects of linearity, hysteresis, and repeatability. Analog output adds 0.005% of span.
2. For zero based spans and reference conditions of: 25 °C (77°F), 10 to 55% RH, and 316 Stainless Steel barrier diaphragm.

Operating Conditions – All Models

Parameter	Reference Condition		Rated Condition		Operative Limits		Transportation and Storage	
	°C	°F	°C	°F	°C	°F	°C	°F
Ambient Temperature¹	25±1	77±2	-40 to 85	-40 to 185	-40 to 85	-40 to 185	-55 to 120	-67 to 248
Meter Body Temperature²								
STA822/STA82L	25±1	77±2	See Error! Reference source not found.		See Error! Reference source not found.		-55 to 125	-67 to 257
STA840, 84L, 87L	25±1	77±2	-40 to 110	-40 to 230	-40 to 125	-40 to 257	-55 to 125	-67 to 257
Humidity %RH	10 to 55		0 to 100		0 to 100		0 to 100	
Vacuum Region - Minimum Pressure STA822, 82L, 840,84L, 87L	See Figure 2. Operate within specifications above 25 mmHgA (33 mbarA). Short term ³ exposure to full vacuum will not result in damage.							
Supply Voltage, Current, and Load Resistance (HART & DE)	10.8 to 42.4 Vdc at terminals (IS versions limited to 30 Vdc) 0 to 1,440 ohms (as shown in Figure 3)							
Maximum Allowable Working Pressure (MAWP)^{4, 5}	STA822, 82L = 780 mmHgA, 1,040 mbarA STA840, 84L = 500 psia, 35 barA STA87L = 3,000 psia, 210 barA							

¹ LCD Display operating temperature -20°C to +70°C Storage temperature -30°C to 80°C.

² Silicone 704 minimum temperature rating is 0°C (32°F)

³ Short term equals 2 hours at 70°C (158°F)

⁴ Units can withstand overpressure of 1.5 x MAWP without damage

⁵ Consult factory for MAWP of ST 700 transmitters with CRN approval

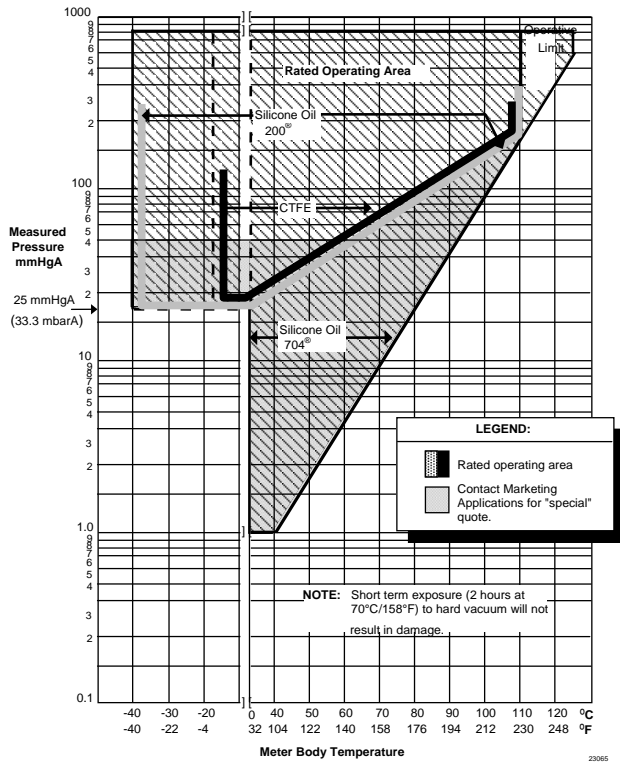

Figure 2 - Measured pressure versus meter body Temperature chart for STA722, 72L

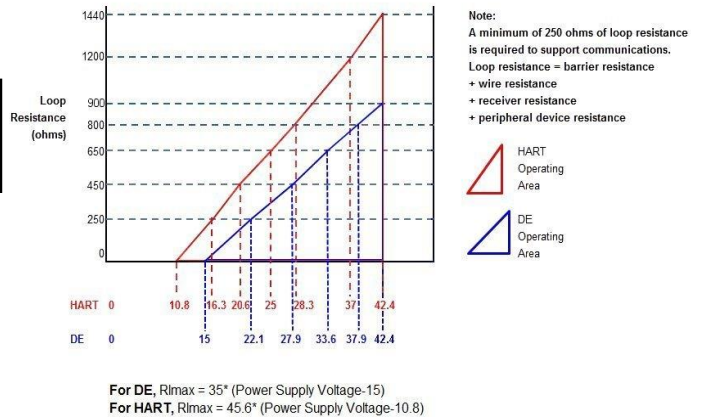

Figure 2 - Supply voltage and loop resistance chart & calculations

Performance Under Rated Conditions – All Models

Parameter	Description									
Analog Output Digital Communications:	Two-wire, 4 to 20 mA (HART & DE Transmitters only) Honeywell DE, HART 7 protocol or FOUNDATION Fieldbus ITK 6.0.1 compliant All transmitters, irrespective of protocol have polarity insensitive connection.									
HART & DE Output Failure Modes (NAMUR for DE Units requires selecting display and configuration buttons or factory configuration)	<table border="0"> <tr> <td></td> <td style="text-align: center;">Honeywell Standard:</td> <td style="text-align: center;">NAMUR NE 43 Compliance:</td> </tr> <tr> <td>Normal Limits:</td> <td style="text-align: center;">3.8 – 20.8 mA</td> <td style="text-align: center;">3.8 – 20.5 mA</td> </tr> <tr> <td>Failure Mode:</td> <td style="text-align: center;">≤ 3.6 mA and ≥ 21.0 mA</td> <td style="text-align: center;">≤ 3.6 mA and ≥ 21.0 mA</td> </tr> </table>		Honeywell Standard:	NAMUR NE 43 Compliance:	Normal Limits:	3.8 – 20.8 mA	3.8 – 20.5 mA	Failure Mode:	≤ 3.6 mA and ≥ 21.0 mA	≤ 3.6 mA and ≥ 21.0 mA
	Honeywell Standard:	NAMUR NE 43 Compliance:								
Normal Limits:	3.8 – 20.8 mA	3.8 – 20.5 mA								
Failure Mode:	≤ 3.6 mA and ≥ 21.0 mA	≤ 3.6 mA and ≥ 21.0 mA								
Supply Voltage Effect	0.005% of span per volt.									
Transmitter Turn on Time (includes power up & test algorithms)	HART or DE: 2.5 sec Foundation Fieldbus: Host dependant									
Response Time (delay + time constant)	<table border="0"> <tr> <td style="text-align: center;"><u>DE/HART Protocol</u></td> <td style="text-align: center;"><u>FOUNDATION Fieldbus</u></td> </tr> <tr> <td style="text-align: center;">80ms</td> <td style="text-align: center;">150ms (Host Dependant)</td> </tr> </table>	<u>DE/HART Protocol</u>	<u>FOUNDATION Fieldbus</u>	80ms	150ms (Host Dependant)					
<u>DE/HART Protocol</u>	<u>FOUNDATION Fieldbus</u>									
80ms	150ms (Host Dependant)									
Damping Time Constant	HART: Adjustable from 0 to 32 seconds in 0.1 increments. Default Value: 0.5 seconds DE: Discrete values 0, .16, .32, .48, 1, 2, 4, 8, 16, 32 seconds. Default Value: 0.48 seconds									
Vibration Effect	Less than +/- 0.1% of URL w/o damping Per IEC60770-1 field or pipeline, high vibration level (10-2000Hz: 0.21 displacement/3g max acceleration)									
Electromagnetic Compatibility	Meets IEC61326									
Lightning Protection Option	Leakage Current: 10uA max @ 42.4VDC 93C Impulse rating: <table border="0"> <tr> <td style="text-align: center;">8/20uS</td> <td style="text-align: center;">5000A (>10 strikes)</td> <td style="text-align: center;">10000A (1 strike min.)</td> </tr> <tr> <td style="text-align: center;">10/1000uS</td> <td style="text-align: center;">200A (> 300 strikes)</td> <td></td> </tr> </table>	8/20uS	5000A (>10 strikes)	10000A (1 strike min.)	10/1000uS	200A (> 300 strikes)				
8/20uS	5000A (>10 strikes)	10000A (1 strike min.)								
10/1000uS	200A (> 300 strikes)									

Materials Specifications (see model selection guide for availability/restrictions with various models)

Parameter	Description
Barrier Diaphragms Material	STA800: 316L SS, Hastelloy® C-276 ² , Monel® 400 ³ , Tantalum, Gold-plated 316L SS, Gold-plated Hastelloy® C-276, Gold-plated Monel® 400 STA80L: 316L SS, Hastelloy C-276
Process Head Material	STA800: Carbon Steel (Zinc Plated) ⁵ , 316 SS ⁴ , Hastelloy® C-276 ⁶ , Monel® 400 ⁷ STG80L: 316L SS, Hastelloy C-276 ⁶
Vent/Drain Valves & Plugs ¹	STA800: 316 SS ⁴ , Hastelloy C-276 ² , Monel 400 ⁷ STA80L: N/A
Head Gaskets	STA800: Glass-filled PTFE standard. Viton® and graphite are optional. STA80L: N/A
Meter Body Bolting	STA800: Carbon Steel (Zinc plated) standard. Options include 316 SS, NACE A286 SS bolts and nuts or NACE A286 SS bolts and 304 SS nuts STA80L: N/A
Mounting Bracket	Carbon Steel (Zinc-plated) or 304 Stainless Steel or 316Stainless Steel. See Figure 3 & Figure 4
Fill Fluid	Silicone 200, CTFE or Silicone 704
Electronic Housing	Pure Polyester Powder Coated Low Copper (<0.4%)-Aluminum. Meets NEMA 4X, IP66, IP67 and NEMA 7 (explosion proof). All stainless steel housing is optional.
Process Connections	STA800: ½ -inch NPT(female), DIN 19213 (standard) STA80L: ½ -inch NPT(female), ½ -inch NPT male, 9/16 Aminco, DIN19213, G ½ -B Male threaded
Wiring	Accepts up to 16 AWG (1.5 mm diameter).
Dimensions	See Figure 3 & Figure 4
Net Weight	STA800: 8.3 pounds (3.8 Kg). STA80L: 3.6 pounds (1.6 Kg) with Aluminum Housing

¹ Vent/Drains are sealed with Teflon®² Hastelloy® C-276 or UNS N10276³ Monel® 400 or UNS N04400⁴ Supplied as 316 SS or as Grade CF8M, the casting equivalent of 316 SS.⁵ Carbon Steel heads are zinc-plated and not recommended for water service due to hydrogen migration. For that service, use 316 stainless steel wetted Process Heads.⁶ Hastelloy® C-276 or UNS N10276. Supplied as indicated or as Grade CW12MW, the casting equivalent of Hastelloy® C-276⁷ Monel® 400 or UNS N04400. Supplied as indicated or as Grade M30C, the casting equivalent of Monel® 400

Communications Protocols & Diagnostics

HART Protocol

Version:

HART 7

Power Supply

Voltage: 10.8 to 42.4Vdc at terminals

Load: Maximum 1440 ohms See figure 2

Minimum Load: 0 ohms. (For handheld communications a minimum load of 250 ohms is required)

Foundation Fieldbus (FF)

Power Supply Requirements

Voltage: 9.0 to 32.0Vdc at terminals

Steady State Current: 17.6mAdc

Software Download Current: 27.4mAdc

Available Function Blocks

Block Type	Qty	Execution Time
Resource	1	n/a
Transducer	1	n/a
Diagnostic	1	n/a
Analog Input	1*	30 ms
PID w/Autotune	1	45 ms
Integrator	1	30 ms
Signal Char (SC)	1	30 ms
LCD Display	1	n/a
Flow Block	1	30 ms
Input Selector	1	30 ms
Arithmetic	1	30 ms

* All block may have two (2) additional instantiations. All available function blocks adhere to FOUNDATION Fieldbus standards. PID blocks support ideal & robust PID algorithms with full implementation of Auto-tuning.

Link Active Scheduler

Transmitters can perform as a backup Link Active Scheduler and take over when the host is disconnected. Acting as a LAS, the device ensures scheduled data transfers typically used for the regular, cyclic transfer of control loop data between devices on the Fieldbus.

Number of Devices/Segment

Entity IS model: 6 devices/segment

Schedule Entries

18 maximum schedule entries

Number of VCR's: 24 max

Compliance Testing: Tested according to ITK 6.0.1

Software Download

Utilizes Class-3 of the Common Software Download procedure as per FF-883 which allows the field devices of any manufacturer to receive software upgrades from any host.

Honeywell Digitally Enhanced (DE)

DE is a Honeywell proprietary protocol which provides digital communications between Honeywell DE enabled field devices and Hosts.

Power Supply

Voltage: 10.8 to 42.4Vdc at terminals

Load: Maximum 1440 ohms See figure 2

Standard Diagnostics

ST 800 top level diagnostics are reported as either critical or non-critical and readable via the DD/DTM tools or integral display as shown below.

Critical Diagnostics		
HART DD/DTM tools	Advanced Display	Basic Display
Electronic Module DAC Failure	Electronics Module fault	Electronics Module fault
Meter Body NVM Corrupt	Meterbody fault	Meterbody fault
Config Data Corrupt	Electronics Module fault	Electronics Module fault
Electronic Module Diag Failure	Electronics Module fault	Electronics Module fault
Meter Body Critical Failure	Meterbody fault	Meterbody fault
Sensor Comm Timeout	Meterbody Comm fault	Meterbody Comm fault

Non-Critical Diagnostics		
HART DD/DTM tools	Advanced Display	Basic Display
Display Failure	n/a	n/a
Electronic Module Comm Failure	n/a	n/a
Meter Body Excess Correct	Zero Correct (OK or EXCESSIVE) Span Correct (OK or EXCESSIVE)	n/a
Sensor Over Temperature	Meterbody Temp (OK, OVER TEMP)	n/a
Fixed Current Mode	Analog Out mode (Fixed or Normal)	n/a
PV Out of Range	Primary PV (OK or OVERLOAD)	n/a
No Factory Calibration	Factory Cal (OK, NO FACTORY CAL)	n/a
No DAC Compensation	DAC Temp Comp (OK, NO COMPENSATION)	n/a
LRV Set Error – Zero Config Button	n/a	n/a
URV Set Error – Span Config Button	n/a	n/a
AO Out of Range	n/a	n/a
Loop Current Noise	n/a	n/a
Meter Body Unreliable Comm	Meterbody Comm (OK, SUSPECT)	n/a
Tamper Alarm	n/a	n/a
No DAC Calibration	n/a	n/a
Sensor Supply Voltage Low	Supply Voltage (OK, LOW, or HIGH)	n/a

Refer to ST 800 diagnostics tech note for additional level diagnostics.

Other Certification Options

Materials

- NACE MRO175, MRO103, ISO15156

Approval Certifications:

AGENCY	TYPE OF PROTECTION	COMM. OPTION	FIELD PARAMETERS	AMBIENT TEMP (Ta)
FM Approvals™	Explosionproof: Class I, Division 1, Groups A, B, C, D; Dust Ignition Proof: Class II, III, Division 1, Groups E, F, G; T4 Class I, Zone 0/1, AEx d IIC Ga/Gb Class II, Zone 21, AEx tb IIIC Db T 95°C	All	Note 1	T5: -50 °C to 85°C T6: -50 °C to 65°C
	Intrinsically Safe: Class I, II, III, Division 1, Groups A, B, C, D, E, F, G; T4 Class I, Zone 0, AEx ia IIC Ga T4 FISCO Field Device (Only for FF Option) Ex ia IIC T4	4-20 mA / DE/ HART	Note 2a	-50 °C to 70°C
	Nonincendive: Class I, Division 2, Groups A, B, C, D locations, Class I, Zone 2, AEx nA IIC Gc T4	4-20 mA / DE/ HART/ Foundation Fieldbus	Note 1	-50 °C to 85°C
	Enclosure: Type 4X/ IP66/ IP67	All	All	-
	Explosion Proof: Class I, Division 1, Groups A, B, C, D; Dust Ignition Proof: Class II, III, Division 1, Groups E, F, G; Ex d IIC Ga Ex tb IIIC Db T 95°C	All	Note 1	T5: -50 °C to 85°C T6: -50 °C to 65°C
	Intrinsically Safe: Class I, II, III, Division 1, Groups A, B, C, D, E, F, G; T4 Ex ia IIC Ga T4 FISCO Field Device (Only for FF Option) Ex ia IIC T4	4-20 mA / DE/ HART	Note 2a	-50 °C to 70°C
Canadian Standards Association (CSA)	Nonincendive: Class I, Division 2, Groups A, B, C, D; T4 Ex nA IIC Gc T4	4-20 mA / DE/ HART/ Foundation Fieldbus	Note 1	-50 °C to 85°C
	Enclosure: Type 4X/ IP66/ IP67	All	All	-

Approval Certifications: (Continued)

ATEX	Flameproof: II 1/2 G Ex d IIC Ga/Gb II 2 D Ex tb IIIC Db T 95°C	All	Note 1	T5: -50 °C to 85°C T6: -50 °C to 65°C
	Intrinsically Safe: II 1 G Ex ia IIC Ga T4	4-20 mA / DE/ HART	Note 2a	-50 °C to 70°C
	FISCO Field Device (Only for FF Option) Ex ia IIC T4	Foundation Fieldbus	Note 2b	-50 °C to 70°C
	Nonincendive: II 3 G Ex nA IIC Gc T4	4-20 mA / DE/ HART/ Foundation Fieldbus	Note 1	-50 °C to 85°C
	Enclosure: IP66/ IP67	All	All	-
IECEX (World)	Flameproof : Ex d IIC Ga/Gb Ex tb IIIC Db T 95°C	All	Note 1	T5: -50 °C to 85°C T6: -50 °C to 65°C
	Intrinsically Safe: Ex ia IIC Ga T4	4-20 mA / DE/ HART	Note 2a	-50 °C to 70°C
	FISCO Field Device (Only for FF Option) Ex ia IIC T4	Foundation Fieldbus	Note 2b	-50 °C to 70°C
	Nonincendive: Ex nA IIC Gc T4	4-20 mA / DE/ HART/ Foundation Fieldbus	Note 1	-50 °C to 85°C
	Enclosure: IP66/ IP67	All	All	-
SAEx (South Africa)	Flameproof : Ex d IIC Ga/Gb T4 Ex tb IIIC Db T 95°C	All	Note 1	-50 °C to 85°C
	Intrinsically Safe: Ex ia IIC Ga T4	4-20 mA / DE/ HART	Note 2a	-50 °C to 70°C
	FISCO Field Device (Only for FF Option) Ex ia IIC T4	Foundation Fieldbus	Note 2b	-50 °C to 70°C
	Nonincendive: Ex nA IIC Gc T4	4-20 mA / DE/ HART/ Foundation Fieldbus	Note 1	-50 °C to 85°C
	Enclosure: IP66/ IP67	All	All	-
INMETRO (Brazil)	Flameproof: Ex d IIC Ga/ Gb T4 Ex tb IIIC Db T 95°C	All	Note 1	50 °C to 85°C
	Intrinsically Safe: Ex ia IIC Ga T4	4-20 mA / DE/ HART	Note 2a	50 °C to 70°C
	FISCO Field Device (Only for FF Option) Ex ia IIC T4	Foundation Fieldbus	Note 2b	50 °C to 70°C
	Nonincendive: Ex nA IIC Gc T4	4-20 mA / DE/ HART/ Foundation Fieldbus	Note 1	-50 °C to 85°C
	Enclosure : IP 66/67	All	All	-

Approval Certifications: (Continued)

NEPSI (China)	Flameproof: Ex d IIC Ga/Gb T4 Ex tb IIIC Db T 85°C	All	Note 1	-50 °C to 85°C
	Intrinsically Safe: Ex ia IIC Ga T4	4-20 mA / DE/ HART	Note 2a	-50 °C to 70°C
	FISCO Field Device (Only for FF Option) Ex ia IIC T4	Foundation Fieldbus	Note 2b	-50 °C to 70°C
	Nonincendive: Ex nA IIC Gc T4	4-20 mA / DE/ HART/ Foundation Fieldbus	Note 1	-50 °C to 85°C
	Enclosure : IP 66/67	All	All	-
GOST	Flameproof: 1 Ex d IIC Ga/Gb T4 Ex tb IIIC Db T 85°C	All	Note 1	-50 °C to 85°C
	Intrinsically Safe: 0 Ex ia IIC Ga T4	4-20 mA / DE/ HART	Note 2a	-50 °C to 70°C
	FISCO Field Device (Only for FF Option) Ex ia IIC T4	Foundation Fieldbus	Note 2b	-50 °C to 70°C
	Enclosure : IP 66/67	All	All	

Notes:

1. Operating Parameters:

Voltage= 11 to 42 V DC Current= 4-20 mA Normal
= 10 to 30 V (FF) = 30 mA (FF)

2. Intrinsically Safe Entity Parameters

a. Analog/ DE/ HART Entity Values:

V_{max}= U_i = 30V I_{max}= I_i= 105mA C_i = 4.2nF L_i =984 uH P_i =0.9W

Transmitter with Terminal Block Revision E or Later

V_{max}= U_i = 30V I_{max}= I_i= 225mA C_i = 4.2nF L_i = 0 P_i =0.9W

Note : Transmitter with Terminal Block Revision E or later

The revision is on the label that is on the module. There will be two lines of text on the label:

- First is the Module Part #: 50049839-001 or 50049839-002
- Second line has the supplier information, along with the REVISION:
XXXXXXX-EXXXX, THE "X" is production related, THE POSITION of the "E" IS THE REVISION.

b. Foundation Fieldbus- Entity Values

V_{max}= U_i = 30V I_{max}= I_i= 180mA C_i = 0nF L_i = 984 uH P_i =1W

Transmitter with Terminal Block Revision F or Later

V_{max}= U_i = 30V I_{max}= I_i= 225mA C_i =0nF L_i = 0 P_i =1 W

FISCO Field Device I_{max}= I_i= 380 mA C_i = 0nF L_i = 0 P_i =5.32 W

V_{max}= U_i = 17.5V

Note : Transmitter with Terminal Block Revision F or later

The revision is on the label that is on the module. There will be two lines of text on the label:

- First is the Module Part #: 50049839-003 or 50049839-004
- Second line has the supplier information, along with the REVISION:
XXXXXXX-EXXXX, THE "X" is production related, THE POSITION of the "E" IS THE REVISION.

Approval Certifications: (Continued)

Marine Certificates	<p>This certificate defines the certifications covered for the ST 800 Pressure Transmitter family of products, including the SMV 800 Smart Multivariable Transmitter. It represents the compilation of the five certificates Honeywell currently has covering the certification of these products into marine applications.</p> <p>For ST 800 Smart Pressure Transmitter and SMV800 Smart Multivariable Transmitter</p>																
	<p>American Bureau of Shipping (ABS) - 2009 Steel Vessel Rules 1-1-4/3.7, 4-6-2/5.15, 4-8-3/13 & 13.5, 4-8-4/27.5.1, 4-9-7/13. Certificate number: 04-HS417416-PDA</p>																
	<p>Bureau Veritas (BV) - Product Code: 389:1H. Certificate number: 12660/B0 BV</p>																
	<p>Det Norske Veritas (DNV) - Location Classes: Temperature D, Humidity B, Vibration A, EMC B, Enclosure C. For salt spray exposure; enclosure of 316 SST or 2-part epoxy protection with 316 SST bolts to be applied. Certificate number: A-11476</p>																
	<p>Korean Register of Shipping (KR) - Certificate number: LOX17743-AE001</p>																
	<p>Lloyd's Register (LR) - Certificate number: 02/60001(E1) & (E2)</p>																
SIL 2/3 Certification	<p>IEC 61508 SIL 2 for non-redundant use and SIL 3 for redundant use according to EXIDA and TÜV Nord Sys Tec GmbH & Co. KG under the following standards: IEC61508-1: 2010; IEC 61508-2: 2010; IEC61508-3: 2010.</p>																
MEASUREMENT INSTRUMENTS DIRECTIVE (MID) 2004/ 22/ EC	<p>Certificate Issued by NMI Certin B.V. Mechanical Class: M3 Electromagnetic Environment: E3 Ambient Temperature Range: -25 °C to + 55 °C</p> <table border="1" style="margin-left: auto; margin-right: auto;"> <thead> <tr> <th>Unit</th> <th>Custom Calibration</th> </tr> </thead> <tbody> <tr> <td>STD820</td> <td>0 to 1000 mBar</td> </tr> <tr> <td>STD830</td> <td>0 to 7 Bar</td> </tr> <tr> <td>STA84L</td> <td>0 to 35 Bar A</td> </tr> <tr> <td>STG84L</td> <td>0 to 35 Bar</td> </tr> <tr> <td>STD870</td> <td>0 to 100 Bar</td> </tr> <tr> <td>STA87L</td> <td>0 to 100 Bar A</td> </tr> <tr> <td>STG87L</td> <td>0 to 100 Bar</td> </tr> </tbody> </table>	Unit	Custom Calibration	STD820	0 to 1000 mBar	STD830	0 to 7 Bar	STA84L	0 to 35 Bar A	STG84L	0 to 35 Bar	STD870	0 to 100 Bar	STA87L	0 to 100 Bar A	STG87L	0 to 100 Bar
Unit	Custom Calibration																
STD820	0 to 1000 mBar																
STD830	0 to 7 Bar																
STA84L	0 to 35 Bar A																
STG84L	0 to 35 Bar																
STD870	0 to 100 Bar																
STA87L	0 to 100 Bar A																
STG87L	0 to 100 Bar																

Mounting & Dimensional Drawings)

Reference Dimensions: $\frac{\text{millimeters}}{\text{inches}}$

Mounting Configurations (Dual head design)

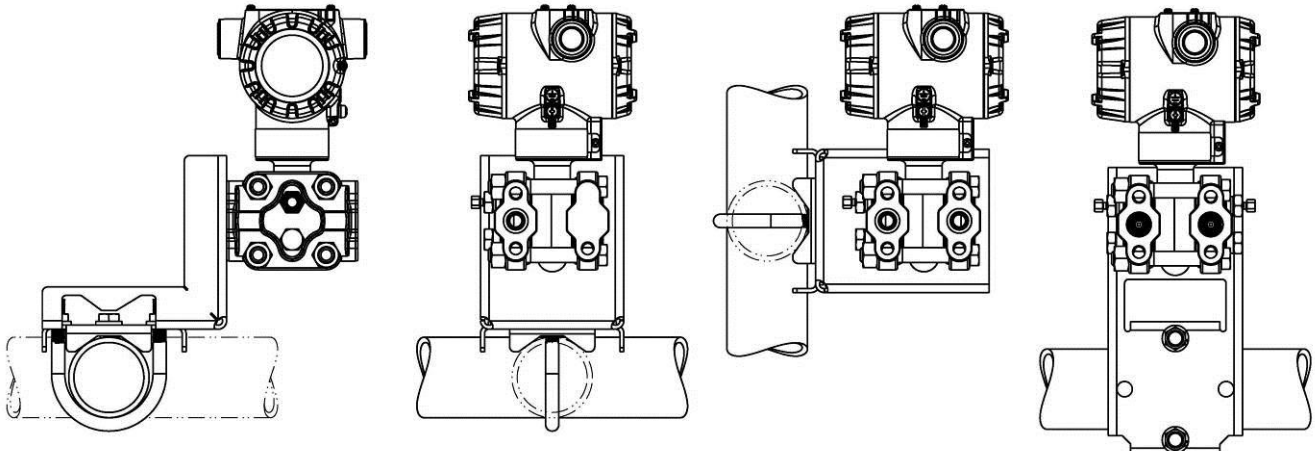

Dimensions (Dual head design)

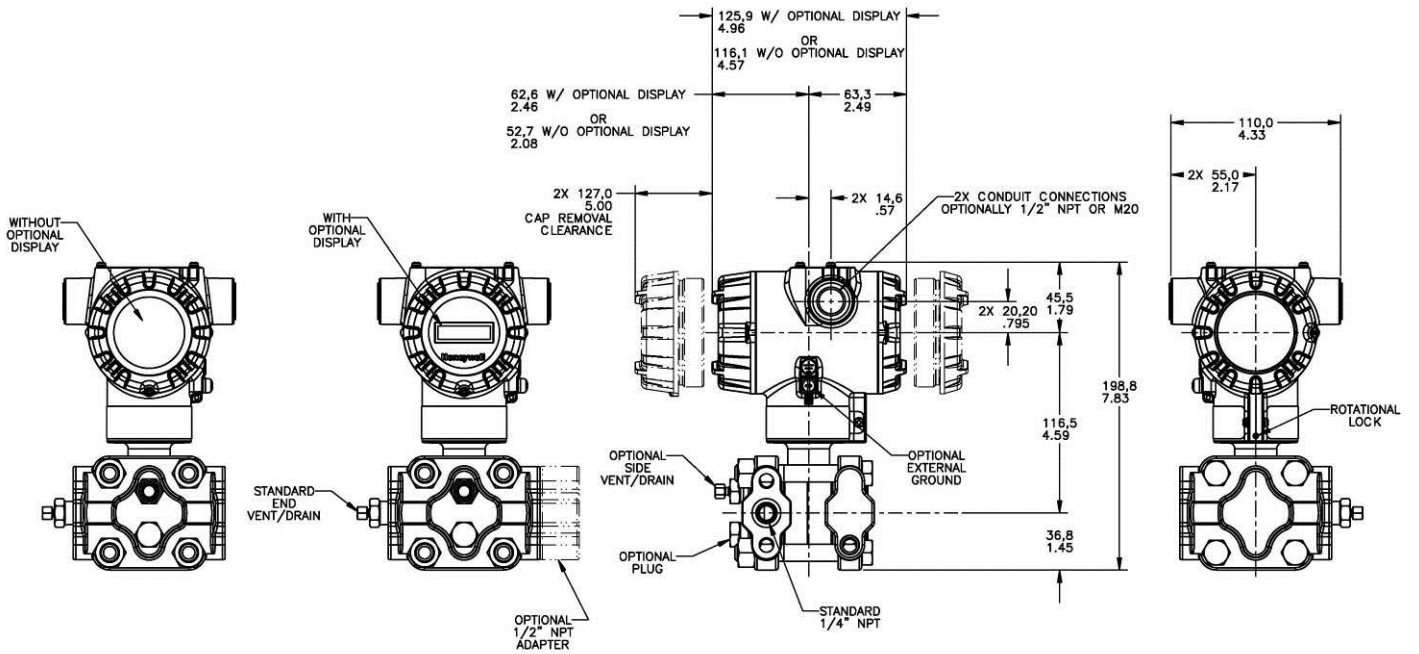
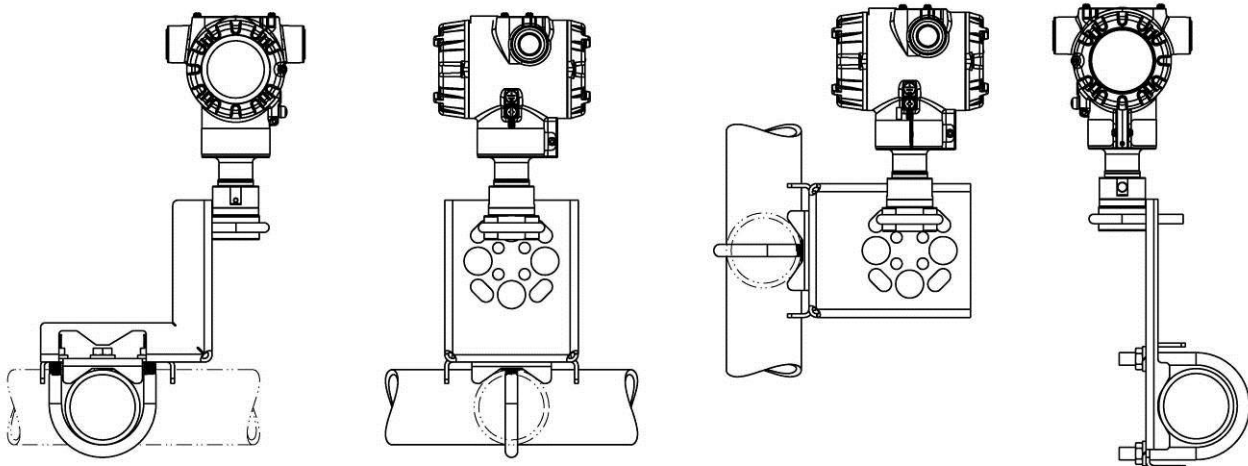

Figure 3 – Typical mounting dimensions of STA822 & STA840 for reference

Reference Dimensions: $\frac{\text{millimeters}}{\text{inches}}$

Mounting Configurations (Inline Designs)



Dimension (Inline Design)

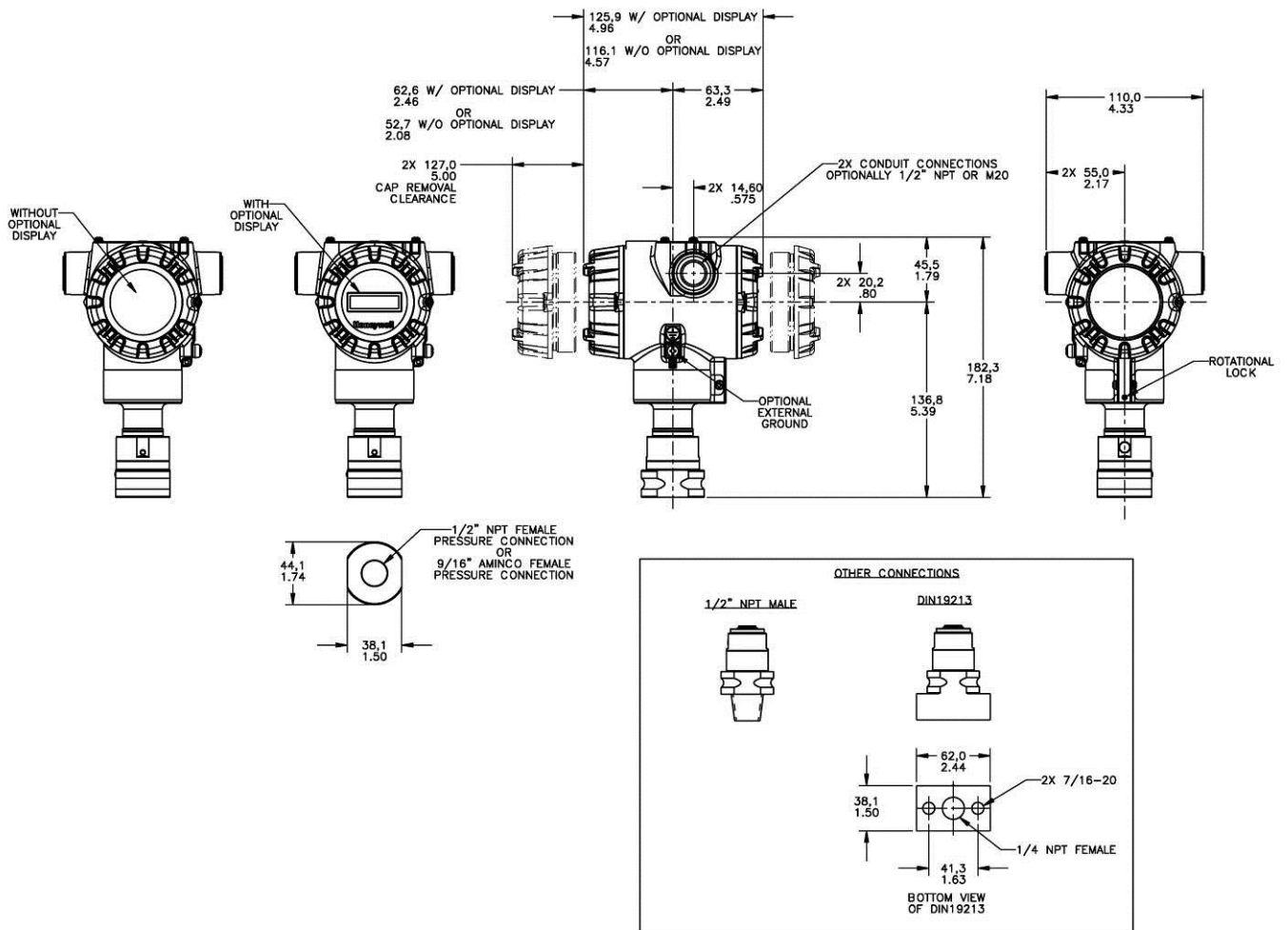

Figure 4 – Typical mounting dimensions of STA82L, STA84L, & STA87L for reference

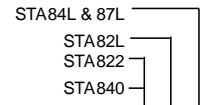

TABLE II Meter Body & Connection Orientation		
Head/Connect Orientation	Standard	High Side Left, Low Side Right ² / Std Head Orientation
	Reversed	Low Side Left, High Side Right ² / Std Head Orientation
	90/Standard	High Side Left, Low Side Right ² / 90° Head Rotation

1	*	*	*
2	*		
3	h		

TABLE III AGENCY APPROVALS	
Approvals	No Approvals Required
	<FM> Explosion proof, Intrinsically Safe, Non-incendive, & Dustproof
	CSA Explosion proof, Intrinsically Safe, Non-incendive, & Dustproof
	ATEX Explosion proof, Intrinsically Safe & Non-incendive
	IECEX Explosion proof, Intrinsically Safe & Non-incendive
	SAEx/CCoE Explosion proof, Intrinsically Safe & Non-incendive
	INMETRO Explosion proof, Intrinsically Safe & Non-incendive
	NEPSI Explosion proof, Intrinsically Safe & Non-incendive

0	*	*	*
A	*	*	*
B	*	*	*
C	*	*	*
D	*	*	*
E	*	*	*
F	*	*	*
G	*	*	*

TABLE IV TRANSMITTER ELECTRONICS SELECTIONS			
a. Electronic Housing Material & Connection Type	Material	Connection	Lightning Protection
	Polyester Powder Coated Aluminum	1/2 NPT	None
	Polyester Powder Coated Aluminum	M20	None
	Polyester Powder Coated Aluminum	1/2 NPT	Yes
	Polyester Powder Coated Aluminum	M20	Yes
	316 Stainless Steel (Grade CF8M)	1/2 NPT	None
	316 Stainless Steel (Grade CF8M)	M20	None
	316 Stainless Steel (Grade CF8M)	1/2 NPT	Yes
	316 Stainless Steel (Grade CF8M)	M20	Yes
b. Output/ Protocol	Analog Output		Digital Protocol
	4-20mA dc		HART Protocol
	4-20mA dc none		DE Protocol Foundation Fieldbus
c. Customer Interface Selections	Indicator	Ext Zero, Span & Config Buttons	Languages
	None	None	None
	None	Yes (Zero/Span Only)	None
	Basic	None	EN
	Basic	Yes	EN
	Advanced	None	EN, GE, FR, IT, SP, RU, TU
	Advanced	Yes	EN, GE, FR, IT, SP, RU, TU
	Advanced	None	EN, CH, JP
Advanced	Yes	EN, CH, JP	

A__	*	*	*
B__	*	*	*
C__	*	*	*
D__	*	*	*
E__	*	*	*
F__	*	*	*
G__	*	*	*
H__	*	*	*

H	*	*	*
D	u	u	u
F	*	*	*

__0	*	*	*
__A	f	f	f
__B	*	*	*
__C	*	*	*
__D	*	*	*
__E	*	*	*
__H	*	*	*
__J	*	*	*

TABLE V CONFIGURATION SELECTIONS			
a. App S/W	Diagnostics		
	Standard Diagnostics		
b. Output Limit, Failsafe & Write Protect Settings	Write Protect	Fail Mode	High & Low Output Limits ³
	Disabled	High> 21.0mAdc	Honeywell Std (3.8 - 20.8 mAdc)
	Disabled	Low< 3.6mAdc	Honeywell Std (3.8 - 20.8 mAdc)
	Enabled	High> 21.0mAdc	Honeywell Std (3.8 - 20.8 mAdc)
	Enabled	Low< 3.6mAdc	Honeywell Std (3.8 - 20.8 mAdc)
	Enabled	N/A	N/A Fieldbus or Profibus
c. General Configuration	General Configuration		
	Factory Standard		
	Customer Configuration (Unit Data Required)		

1__	*	*	*
-----	---	---	---

1	f	f	f
2	f	f	f
3	f	f	f
4	f	f	f
5	g	g	g
6	g	g	g

__S	*	*	*
__C	*	*	*

² Left side/Right side as view ed from the customer connection perspective
³ NAMUR Output Limits 3.8 - 20.5mAdc can be configured by the custom

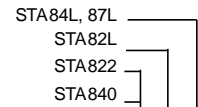

TABLE VI CALIBRATION & ACCURACY SELECTIONS			
	Accuracy	Calibrated Range	Calibration Qty
a. Accuracy and Calibration	Standard	Factory Std	Single Calibration
	Standard	Custom (Unit Data Required)	Single Calibration
	Standard	Custom (Unit Data Required)	Dual Calibration
	Standard	Custom (Unit Data Required)	Triple Calibration
	High Accuracy	Factory Std	Single Calibration
	High Accuracy	Custom (Unit Data Required)	Single Calibration
	High Accuracy	Custom (Unit Data Required)	Dual Calibration
	High Accuracy	Custom (Unit Data Required)	Triple Calibration

A	*	*	*
B	*	*	*
C	*	*	*
D	*	*	*
E	*	*	*
F	*	*	*
G	s	s	s
H	s	s	s

TABLE VII ACCESSORY SELECTIONS		
	Bracket Type	Material
a. Mounting Bracket	None	None
	Angle Bracket	Carbon Steel
	Angle Bracket	304 SS
	Angle Bracket	316 SS
	Marine Approved Bracket	Carbon Steel
	Marine Approved Bracket (In-Line)	Carbon Steel
	Marine Approved Bracket	304 SS
	Marine Approved Bracket (In-Line)	304 SS
	Flat Bracket	Carbon Steel
	Flat Bracket	304 SS
	Flat Bracket	316 SS
b. Customer Tag	Customer Tag Type	
	No customer tag	
	One Wired Stainless Steel Tag (Up to 4 lines 26 char/line)	
c. Unassembled Conduit Plugs & Adapters	Unassembled Conduit Plugs & Adapters	
	No Conduit Plugs or Adapters Required	
	1/2 NPT Male to 3/4 NPT Female 316 SS Certified Conduit Adapter	
	1/2 NPT 316 SS Certified Conduit Plug	
	M20 316 SS Certified Conduit Plug	
	Minifast® 4 pin (1/2 NPT) (not suitable for X-Proof applications)	
Minifast® 4 pin (M20) (not suitable for X-Proof applications)		

0 ___	*	*	*
1 ___	*	*	*
2 ___	*	*	*
3 ___	*	*	*
8 ___	*	*	*
9 ___	*	*	*
4 ___	*	*	*
A ___	*	*	*
5 ___	*	*	*
6 ___	*	*	*
7 ___	*	*	*

_ 0 _ _	*	*	*
_ 1 _ _	*	*	*
_ 2 _ _	*	*	*

_ _ A0	*	*	*
_ _ A2	n	n	n
_ _ A6	n	n	n
_ _ A7	m	m	m
_ _ A8	n	n	n
_ _ A9	m	m	m

TABLE VIII OTHER Certifications & Options: (String in sequence comma delimited (XX, XX, XX,....))	
Certifications & Warranty	None - No additional options required
	Low Temperature Rating (-50 deg C min. ambient temperature)
	NACE MR0175; MR0103; ISO15156 (FC33338) Process wetted parts only
	NACE MR0175; MR0103; ISO15156 (FC33339) Process wetted and non-wetted parts
	Marine (DNV, ABS, BV, KR, LR)
	EN10204 Type 3.1 Material Traceability (FC33341)
	MID Approved Transmitter - Contact Tech Support for specific MID approved ranges
	Certificate of Conformance (F3391)
	Calibration Test Report & Certificate of Conformance (F3399)
	Certificate of Origin (F0195)
	FMEDA (SIL 2/3) Certification (FC33337)
	Over-Pressure Leak Test Certificate (1.5X MAWP) (F3392)
	Cert Clean for O ₂ or CL ₂ service per ASTM G93
	PMI Certification
	Extended Warranty Additional 1 year
	Extended Warranty Additional 2 years
	Extended Warranty Additional 3 years
	Extended Warranty Additional 4 years
Extended Warranty Additional 15 years	

00	*	*	*
LT	w	w	w
FG	*	*	*
F7	c	c	c
MT	d	d	d
FX	*	*	*
MD	*	*	v
F3	*	*	*
F1	*	*	*
F5	*	*	*
FE	j	j	j
TP	*	*	*
OX	e	e	e
PM	*	*	*
01	*	*	*
02	*	*	*
03	*	*	*
04	*	*	*
15	*	*	*

TABLE IX Manufacturing Specials	
Factory	Factory Identification
	0 0 0 0

0 0 0 0	*	*	*
---------	---	---	---

RESTRICTIONS

Restriction Letter	Available Only with		Not Available with	
	Table	Selection(s)	Table	Selection(s)
a			VIII	FG, F7
c	I d	__ 0,N,K,D,B __	I a	D,H,K,L,8, __
d	IV a	C,D,G,H __	VII a	1,2,3,5,6,7 __
e	II b	_ 2 _		
f			IV b	_ F _
g			IV b	_ H, D _
h			I e	4,5,6
			VII a	1,2,3,4,5,6,7 __
j	IV b	_ H _	V b	_ 1,2,6 _
m	IV a	B,D, F, H __		
n	IV a	A,C, E, G __		
p			III	B - No CRN number available
t			1 a	J, K, 7, L, 8
s	I a	A,E _		
u			V a	2
			VII a	C,D,G,H
v	IV a	C,D,G,H __	IV b	_ D,F _
w	II b	_ 1 _	VIII	FE
b	Select Only one option from this group			

Sales and Service

For application assistance, current specifications, pricing, or name of the nearest Authorized Distributor, contact one of the offices below.

ASIA PACIFIC

Honeywell Process Solutions,
(TAC) hfs-tac-support@honeywell.com

Australia

Honeywell Limited
Phone: +(61) 7-3846 1255
FAX: +(61) 7-3840 6481
Toll Free 1300-36-39-36
Toll Free Fax:
1300-36-04-70

China – PRC - Shanghai

Honeywell China Inc.
Phone: (86-21) 5257-4568
Fax: (86-21) 6237-2826

Singapore

Honeywell Pte Ltd.
Phone: +(65) 6580 3278
Fax: +(65) 6445-3033

South Korea

Honeywell Korea Co Ltd
Phone: +(822) 799 6114
Fax: +(822) 792 9015

EMEA

Honeywell Process Solutions,
Phone: + 80012026455 or
+44 (0)1202645583

Email: (Sales)

FP-Sales-Apps@Honeywell.com

or

(TAC)

hfs-tac-support@honeywell.com

AMERICA'S

Honeywell Process Solutions,
Phone: (TAC) 1-800-423-9883 or
215/641-3610
(Sales) 1-800-343-0228

Email: (Sales)

FP-Sales-Apps@Honeywell.com

or

(TAC)

hfs-tac-support@honeywell.com

Specifications are subject to change without notice.

For more information

To learn more about SmartLine Pressure Transmitters visit www.honeywellprocess.com
Or contact your Honeywell Account Manager

Process Solutions

Honeywell

1250 W Sam Houston Pkwy S
Houston, TX 77042

Honeywell Control Systems Ltd
Honeywell House, Skimped Hill Lane
Bracknell, England, RG12 1EB

Shanghai City Centre, 100 Jungi Road
Shanghai, China 20061

www.honeywellprocess.com



Honeywell
AUTHORIZED DISTRIBUTOR

De Gidts & Feldman BV
The Netherlands
w w w . d g f g . n l



INSTRUMENTATION & FILTRATION

Honeywell

34-ST-03-85
March 2016

©2016 Honeywell International Inc.