

Honeywell



UK Page 1

FR Page 7

DE Seite 13

STT171

**STT3000 Smart
Temperature Transmitter**

Operator Manual

Doc. No.: 34-ST-25-25

Revision Date: 2/06

Copyright, Notices, and Trademarks

© Copyright 2006 by Honeywell Inc.

Revision 0 – 2/06

While this information is presented in good faith and believed to be accurate, Honeywell disclaims the implied warranties of merchantability and fitness for a particular purpose and makes no express warranties except as may be stated in its written agreement with and for its customer.

In no event is Honeywell liable to anyone for any indirect, special or consequential damages. The information and specifications in this document are subject to change without notice.

**Honeywell International, Inc.
Industrial Measurement and Control
2500 W. Union Hills Drive
Phoenix, Arizona 85027**

About This Document

Abstract

This document is intended to support the installation and operation of the Model STT171 Smart Temperature Transmitter.

Revision Notes

The following list provides notes concerning all revisions of this document.

Rev. ID	Date	Notes
0	2/06	This document is the initial Honeywell release of the STT171 Transmitter

Contacts

World Wide Web

The following lists Honeywell's World Wide Web sites that will be of interest to our customers.

Honeywell Organization	WWW Address (URL)
Corporate	http://www.honeywell.com
Industrial Measurement and Control	http://www.honeywell.com/imc

Telephone

Contact us by telephone at the numbers listed below.

	Organization	Phone Number
United States and	Honeywell	1-800-423-9883 Tech. Support
Canada		1-888-423-9883 Q&A Faxback (TACFACS)
		1-800-525-7439 Service

Notices

Safety Instructions

Ex installation:

For safe installation of STT171-BS in a hazardous area, the following must be observed. The module must only be installed by qualified personnel who are familiar with the national and international laws, directives and standards that apply to this area.

Year of manufacture can be taken from the first two digits in the serial number.

For Ex data see section 4.3 ATEX Installation Data.

The sensor circuit is not infallibly galvanically isolated from the input circuit. However, the galvanic isolation between the circuits is capable of withstanding a test voltage of 500 Vac during 1 minute.

The transmitter must be mounted in an enclosure in order to provide a degree of ingress protection of at least IP20.

In explosive atmospheres caused by air / dust mixtures:

The transmitter may only be installed in a potentially explosive atmosphere caused by the presence of combustible dust when mounted in a metal enclosure form B according to DIN 43729 that is providing a degree of ingress protection of at least IP 6X in accordance with EN 60529, that is suitable for the application and is correctly installed.

Cable entries and blanking elements shall be used that are suitable for the application and correctly installed.

For an ambient temperature $\geq 60^{\circ}\text{C}$, heat resistant cables shall be used with a rating of at least 20 K above the ambient temperature.

Special Conditions for Safe Use:

If the enclosure in which the transmitter is mounted is made of aluminium and installed in Zone 0, 1 or Zone 20, 21 or 22 it shall not contain by weight more than 6% in total of magnesium and titanium.

The additional enclosure of the apparatus shall be designed and/or installed in such a way that, even in the event of rare incidents, ignition sources due to impact and friction sparks are excluded.

Consigne de sécurité

Installation S.I. :

Pour l'installation de STT171-BS dans les zones dangereuses, conformez-vous aux consignes de sécurité suivantes : l'installation ne doit être réalisée que par du personnel qualifié connaissant la législation nationale et internationale ainsi que les directives et standards régissant ce domaine.

L'année de production ressort des deux premiers chiffres du numéro de série.

Pour les données de sécurité intrinsèque, voir section 4.3 ATEX Installation Data.

L'isolation galvanique entre le circuit du capteur et le circuit d'entrée n'est pas infallible. Cependant, l'isolation galvanique entre les circuits est capable de résister à une tension de test de 500 Vca pendant 1 minute.

Le transmetteur doit être monté dans un boîtier assurant un degré d'étanchéité d'au moins IP20.

Dans les atmosphères explosibles dues à des mélanges d'air avec des poussières :

Le transmetteur doit seulement être installé dans les atmosphères potentiellement explosibles dû à la présence de poussières combustibles quand il est monté dans un boîtier métallique DIN B conformément à DIN 43729 assurant un degré d'étanchéité d'au moins IP 6X conformément à l'EN 60529. Ce boîtier doit convenir à l'application et il doit être correctement installé.

Seulement des raccords de câble et des bouchons convenant à l'application et correctement installés doivent être utilisés.

Pour une température ambiante $\geq 60^{\circ}\text{C}$, il faut utiliser des câbles résistant aux températures élevées avec une capacité nominale d'au moins 20 K au dessus de la température ambiante.

Conditions spécifiques à l'utilisation sûre :

Si le boîtier dans lequel est monté le transmetteur est fait d'aluminium et installé en zone 0, 1 ou zone 20, 21 ou 22, il ne doit contenir en poids plus que 6% en total de magnésium et de titane.

Le boîtier supplémentaire de l'appareil doit être construit et/ou installé dans une telle manière que, même dans le cas d'incidents rares, les sources d'inflammation dues aux impacts et aux étincelles de friction ne peuvent se produire.

Sicherheitsinstruktion

Ex-Installation:

Für sichere Installation von STT171-BS in explosionsgefährdeter Umgebung muss folgendes beobachtet werden. Die Installation muss nur von qualifizierten Personen, die mit den nationalen und internationalen Gesetze, Direktiven und Standards des Gebiets bekannt sind, vorgenommen werden.

Die ersten beiden Ziffern der Seriennummer geben das Produktionsjahr an.

Für Ex-Daten siehe Abschnitt 4.3 ATEX Installation Data.

Die galvanische Trennung zwischen dem Sensorkreis und dem Eingangskreis ist nicht unfehlbar. Allerdings ist die galvanische Trennung zwischen den Kreisen so ausgelegt, dass diese eine Testspannung von 500 Vac für eine Minute aushält.

Der Messumformer muss in einem Gehäuse montiert werden, um die Mindestanforderung des Berührungsschutzes mit dem Schutzgrad IP 20 zu erreichen.

In Explosionsfähige Atmosphären durch Staub/Luft-Gemische:

Der Messumformer darf nur in einer potentiellen explosiven Atmosphäre, basierend auf entflammaren Staub, eingesetzt werden, wenn er in einem Metallkopf Form B gemäß DIN 43729 montiert ist, welcher einen Schutzgrad von mindestens IP 6X gemäß EN 60529 besitzt und für den dementsprechenden Einsatz zugelassen ist.

Es dürfen nur Kabeleinführungen und Abdeckungen eingesetzt werden, welche für die jeweilige Anwendung zugelassen sind.

Bei einer Umgebungstemperatur $\geq 60^{\circ}\text{C}$ müssen hitzebeständige Leitungen eingesetzt werden, welche für eine mindestens 20 K höhere Umgebungstemperatur zugelassen sind.

Sonderbedingungen für sichere Anwendung:

Wenn das Gehäuse, in dem der Messumformer montiert ist, aus Aluminium gemacht ist und es in Zone 0, 1 oder Zone 20, 21 oder 22 installiert ist, es muss höchstens eine Totale von 6% Magnesium und Titanium einhalten.

Das zusätzliche Gehäuse des Apparats ist so zu konstruieren und herzustellen, dass Zündquellen (Stöße und Reibungsfunken) selbst bei selten auftretenden Gerätestörungen vermieden werden.

CONTENTS

1. 2-WIRE PROGRAMMABLE TRANSMITTER MODEL STT171	1
1.1 Features	1
1.2 Application	1
1.3 Technical Characteristics	1
1.4 Installation	2
1.5 Electrical Connections	2
1.6 Block Diagram.....	3
1.7 Programming.....	4
1.8 Mechanical Specifications	5
1.9 Mounting of Sensor Wires	6
2. TRANSMETTEUR 2-FILS PROGRAMMABLE STT171	7
2.1 Caractères.....	7
2.2 Application	7
2.3 Caractéristiques techniques	7
2.4 Installation	8
2.5 Connexions	8
2.6 Schema de Principe.....	9
2.7 Programmation	10
2.8 Dimensions mécaniques.....	11
2.9 Montage des fils du capteur	12
3. 2-DRAHT PROGRAMMIERBARER MESSUMFORMER STT171.....	13
3.1 Das Unterscheidungsmerkmal.....	13
3.2 Verwendung	13
3.3 Technische Merkmale	13
3.4 Installation	14
3.5 Anschlüsse	14
3.6 Blockdiagramm	15
3.7 Programmierung	16

3.8 Abmessungen	17
3.9 Montage von Fühlerleitungen	18

4. INSTALLATION DRAWINGS.....	19
4.1 FM Installation Drawing 50016324	19
4.1.1 Model STT171-BS and STT173-BS	19
4.1.2 The Entity Concept	20
4.2 CSA Installation Drawing 50016326	21
4.2.1 Model STT171-BS, STT173-BS and STT17H-BS.....	21
4.3 ATEX Installation Data.....	23
5. DECLARATION OF CONFORMITY	24

FIGURES

Figure 1-1	2-Wire installation in Control Room	2
Figure 1-2	Electrical Connections.....	2
Figure 1-3	Block Diagram	3
Figure 1-4	Programming	4
Figure 1-5	Mechanical Specifications.....	5
Figure 1-6	Mounting of Sensor Wires.....	6
Figure 2-1	Installation 2-fils en sale de contrôle.....	8
Figure 2-2	Connexions.....	8
Figure 2-3	Schema de Principe	9
Figure 2-4	Programmation	10
Figure 2-5	Dimensions mécaniques	11
Figure 2-6	Montage des fils du capteur	12
Figure 3-1	2-Draht-Installation	14
Figure 3-2	Anschlüsse	14
Figure 3-3	Blockdiagramm	15
Figure 3-4	Programmierung	16
Figure 3-5	Abmessungen.....	17
Figure 3-6	Montage von Fühlerleitungen.....	18
Figure 4-1	Model STT171-BS and STT173-BS [FM Installation Drawing].....	19
Figure 4-2	Model STT171-BS, STT173-BS and STT17H-BS [Connections with separate power supply and receiver].....	21
Figure 4-3	Model STT171-BS, STT173-BS and STT17H-BS [Connections with power supply and barrier built into receiver]	22

1. 2-WIRE PROGRAMMABLE TRANSMITTER MODEL STT171

1.1 Features

- RTD or Ohm Input
- High Measurement Accuracy
- 3-Wire Connection
- Programmable sensor error value
- For DIN form B sensor head mounting

1.2 Application

- Linearised temperature measurement with Pt100 or Ni100 sensors.
- Conversion of linear resistance variation to a standard analogue current signal, for instance from valves or Ohmic level sensors.

1.3 Technical Characteristics

- Within a few seconds the user can program the STT171 to measure temperatures within all RTD ranges defined by the norms.
- The RTD and resistance inputs have cable compensation for 3-wire connection.

1.4 Installation

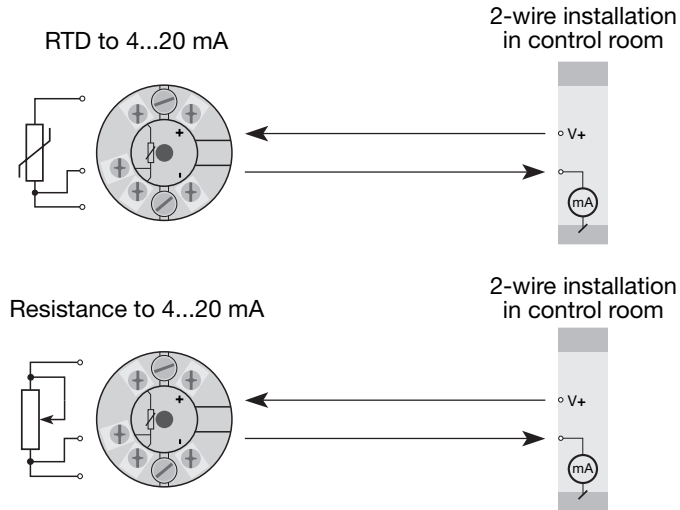

Figure 1-1 2-Wire installation in Control Room

1.5 Electrical Connections

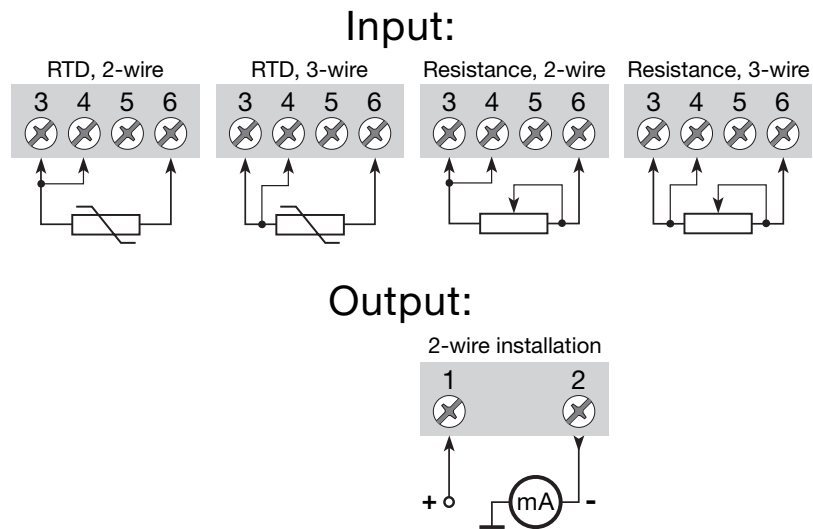

Figure 1-2 Electrical Connections

1.6 Block Diagram

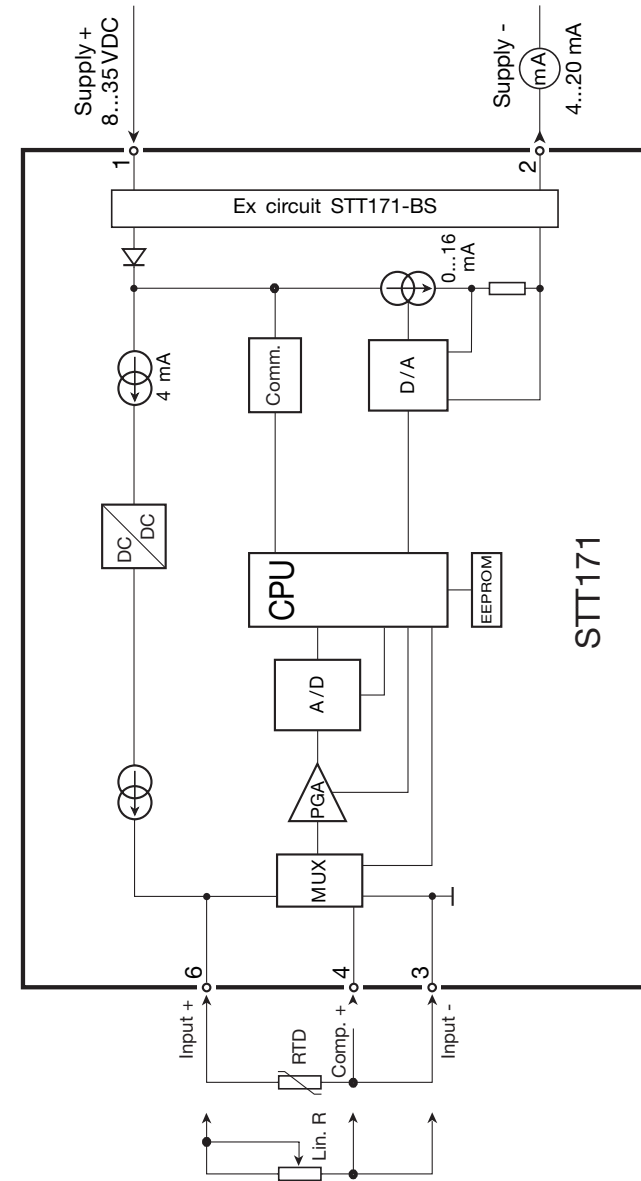

Figure 1-3 Block Diagram

1.7 Programming

- STT17C is a communications interface that is needed for programming the STT171.
- For programming, please refer to Figure 1-4 and the help function in STT17C.
- STT17C is not approved for communication with modules installed in hazardous (Ex) areas.

ORDER: STT17C

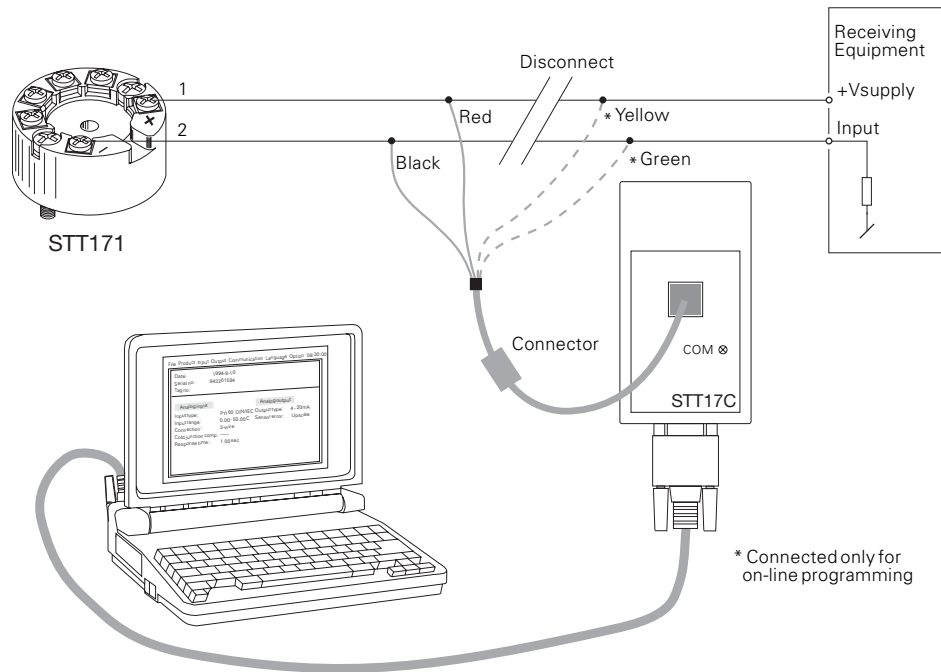

Figure 1-4 Programming

1.8 Mechanical Specifications

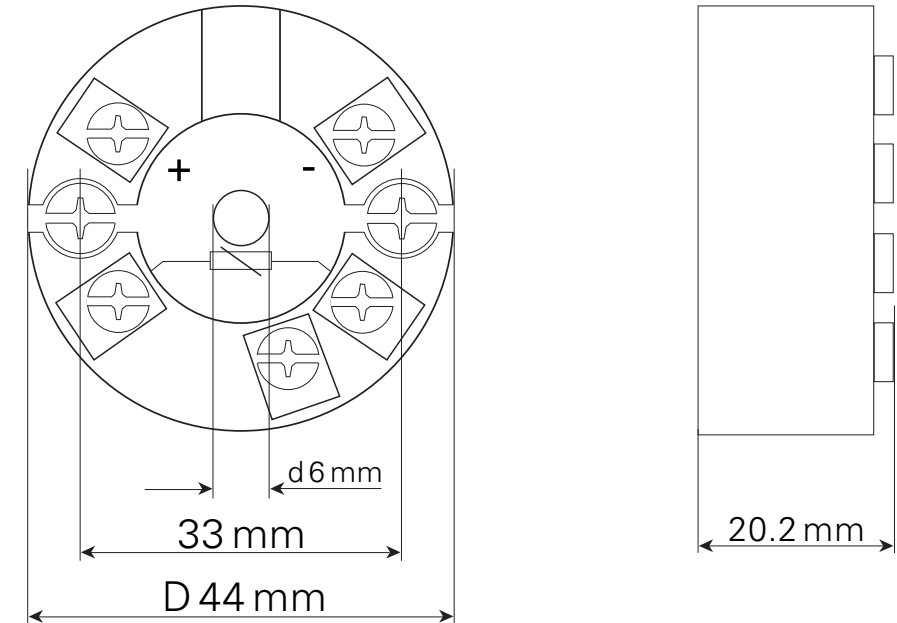
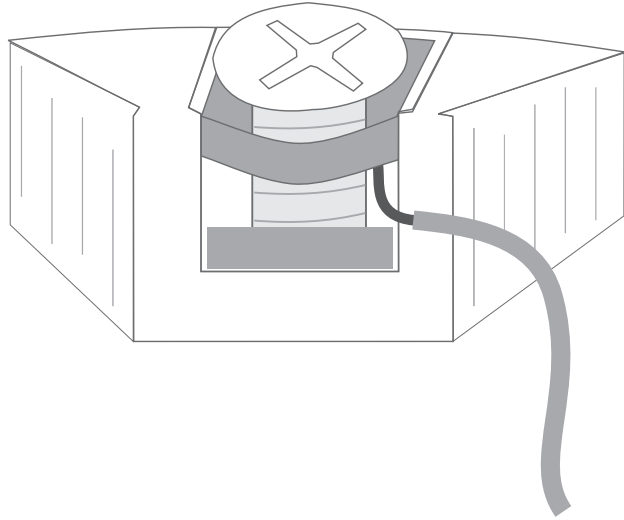

Figure 1-5 Mechanical Specifications

1.9 Mounting of Sensor Wires



Wires must be mounted between the metal plates

Figure 1-6 Mounting of Sensor Wires

2. TRANSMETTEUR 2-FILS PROGRAMMABLE STT171

2.1 Caractères

- Entrée RTD ou résistance
- Grande précision de mesure
- Connexion aux sondes à 3 fils
- Sécurité programmable
- Pour tête de sonde DIN B

2.2 Application

- Mesure linéarisée de la température avec un capteur Pt100 ou Ni100.
- Conversion d'une résistance linéaire en un signal courant standard analogique pour mesurer par exemple le niveau ou la position d'une vanne.

2.3 Caractéristiques techniques

- Le STT171 peut être programmé de manière simple et rapide.
- Compensation de ligne pour des entrées RTD et résistance avec un raccordement à 3 fils.

2.4 Installation

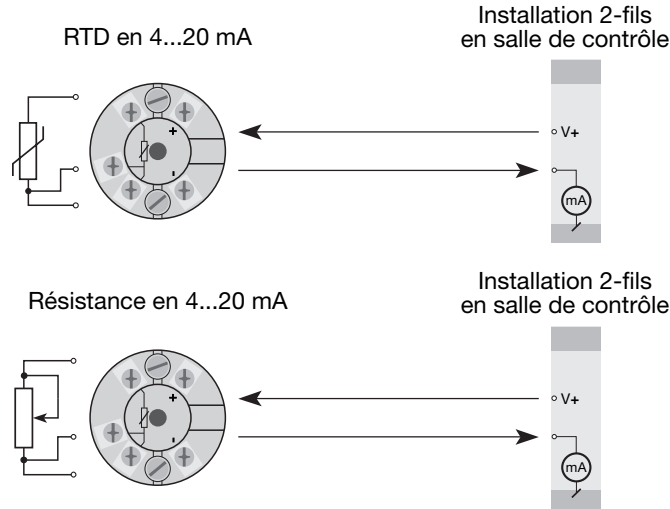

Figure 2-1 Installation 2-fils en sale de contrôle

2.5 Connexions

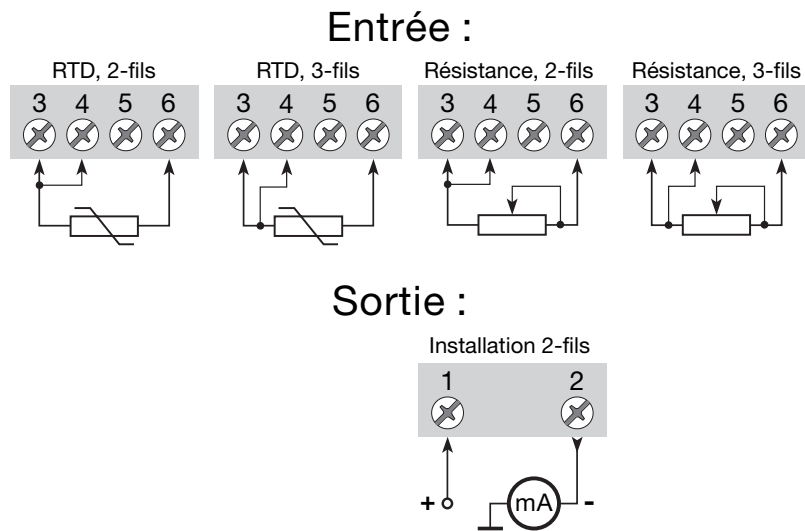

Figure 2-2 Connexions

2.6 Schema de Principe

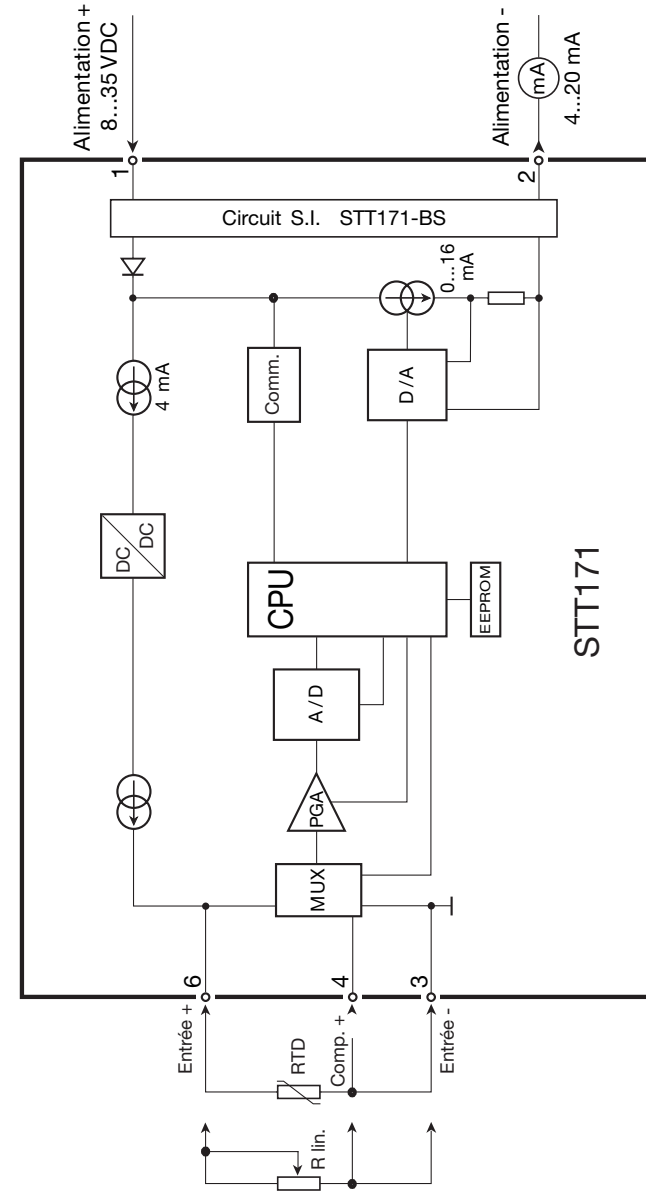

Figure 2-3 Schema de Principe

2.7 Programmation

- STT17C est un kit de programmation permettant de programmer le STT171.
- Pour le raccordement du STT17C, veuillez vous reporter au schéma ci-dessous et à l'aide en ligne du logiciel STT17C.
- STT17C ne doit pas être utilisé pour communication avec des modules installés en zone dangereuse.

Numéro de référence : STT17C

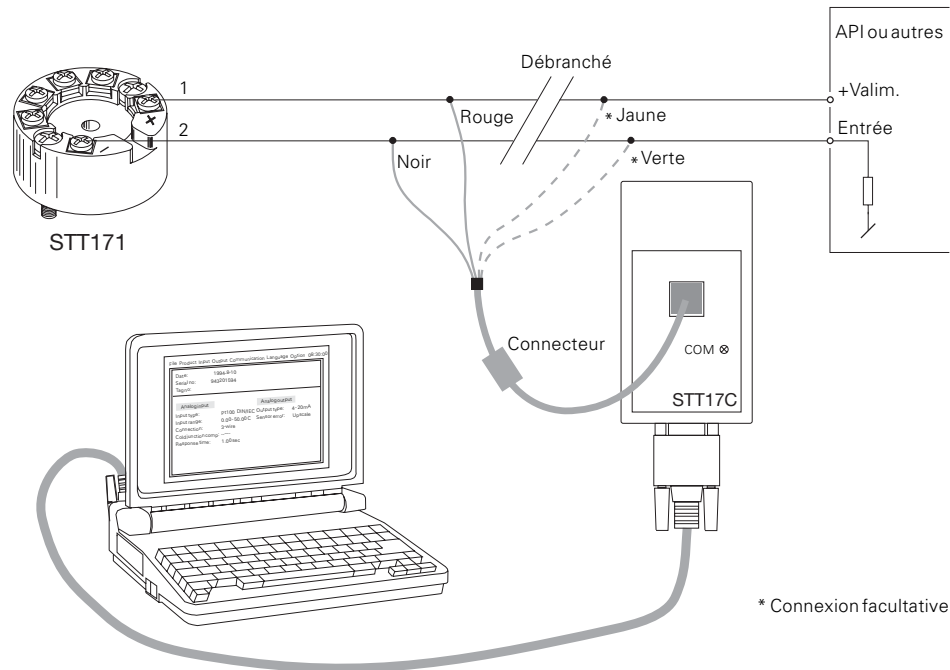

Figure 2-4 Programmation

2.8 Dimensions mécaniques

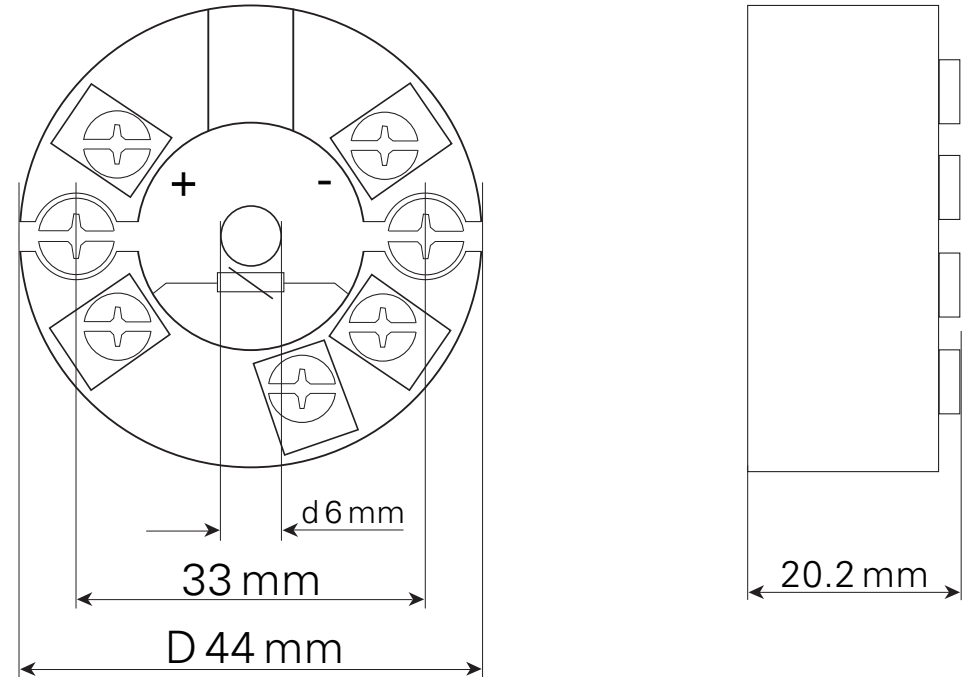
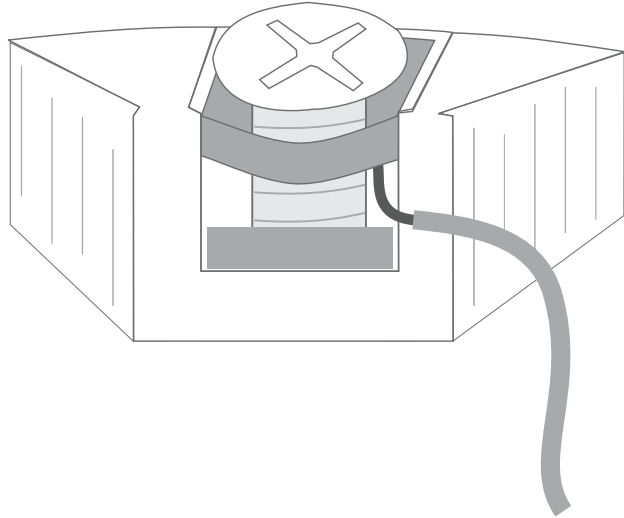

Figure 2-5 Dimensions mécaniques

2.9 Montage des fils du capteur



Les fils doivent être montés entre les plaques métalliques

Figure 2-6 Montage des fils du capteur

3. 2-DRAHT PROGRAMMIERBARER MESSUMFORMER STT171

3.1 Das Unterscheidungsmerkmal

- Eingang für WTH oder Ω
- Hohe Messgenauigkeit
- 3-Leiter-Anschluss
- Programmierbare Sensorfehlanzeige
- Für Einbau in Anschlusskopf DIN Form B

3.2 Verwendung

- Linearisierte Temperaturmessung mit Pt100 oder Ni100 Sensoren.
- Umwandlung von linearer Widerstandsänderung in ein analoges Standard-Stromsignal, z.B. von Ventilen oder Niveau-Messwertgeber.

3.3 Technische Merkmale

- STT171 kann vom Benutzer innerhalb von wenigen Sekunden zur Messung in allen genormten WTH-Temperaturbereiche programmiert werden.
- Der WTH- und Widerstandseingang haben Leitungskompensation bei 3-Leiter-Anschluss.

3.4 Installation

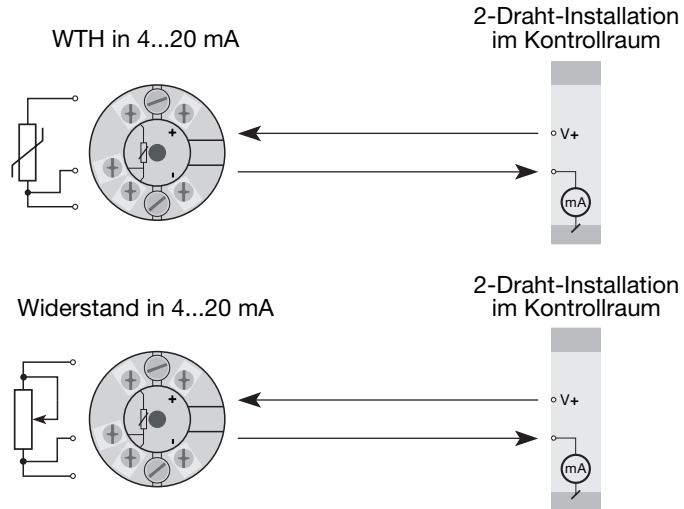
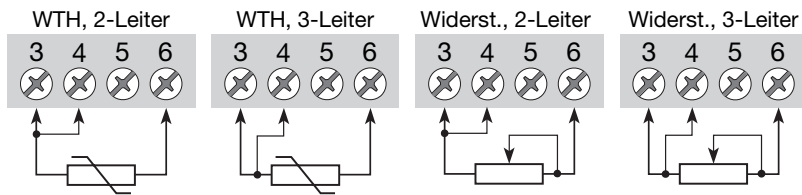

Figure 3-1 2-Draht-Installation

3.5 Anschlüsse

Eingang:



Ausgang:

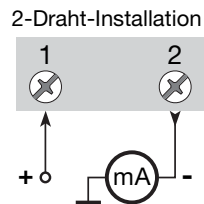

Figure 3-2 Anschlüsse

3.6 Blockdiagramm

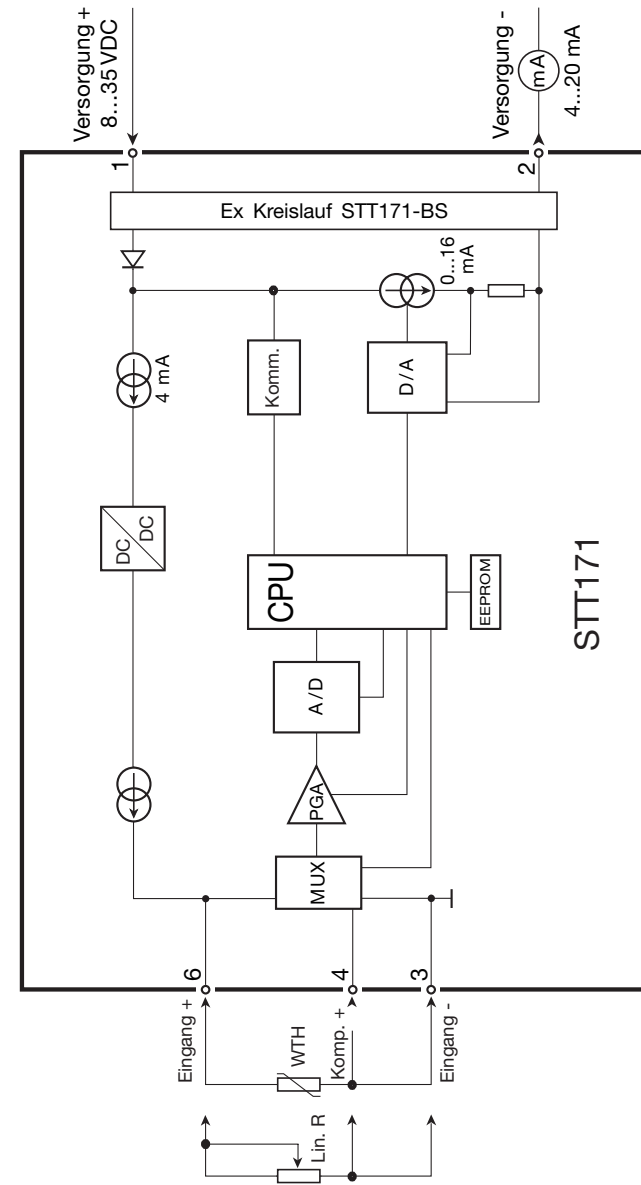

Figure 3-3 Blockdiagramm

3.7 Programmierung

- STT17C ist eine batteriegespeiste Schnittstelle zur Programmierung des PRetop STT171.
- Bezüglich Programmierung verweisen wir auf die nachfolgende Zeichnung und die "Hilfe"-Funktion im STT17C.
- STT17C darf nicht zur Kommunikation mit Modulen, die in Ex-gefährdeten Bereichen installiert sind, benutzt werden.

Bestellangaben: STT17C

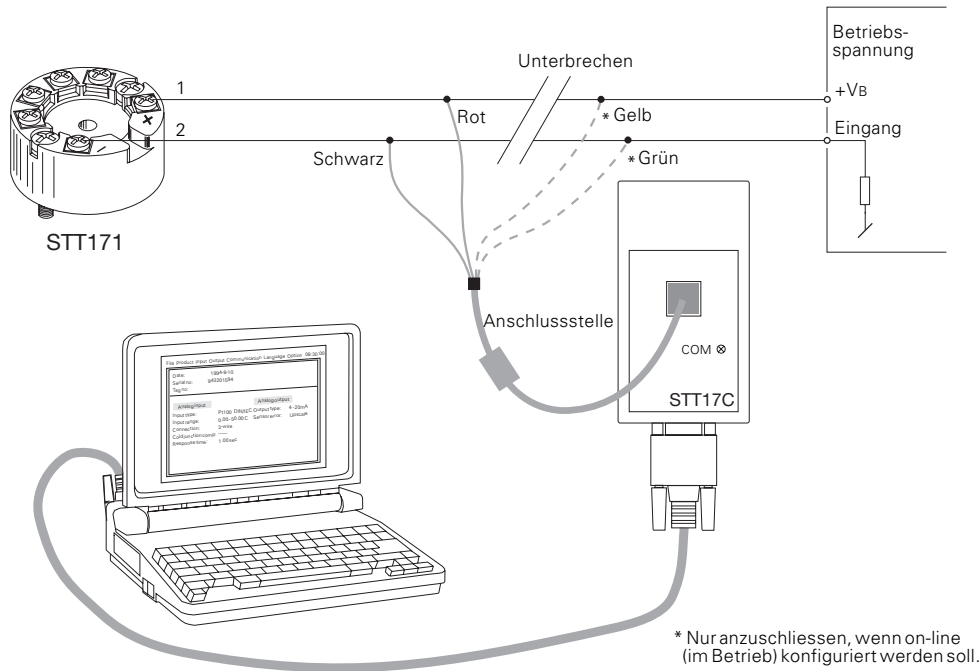

Figure 3-4 Programmierung

3.8 Abmessungen

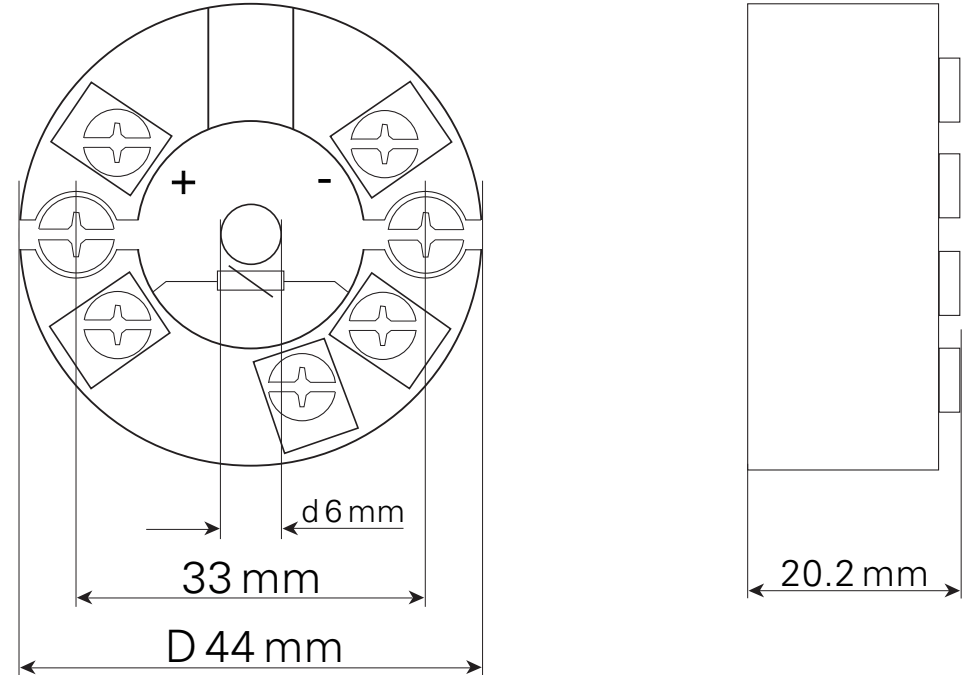
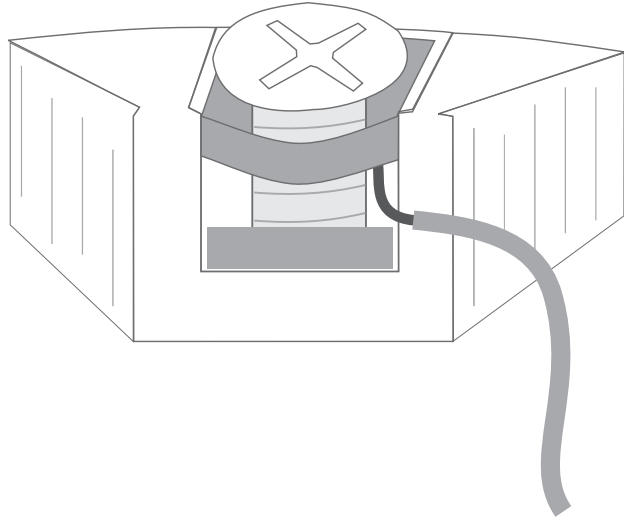

Figure 3-5 Abmessungen

3.9 Montage von Fühlerleitungen



Die Leitungen müssen zwischen den Metallplatten montiert werden

Figure 3-6 Montage von Fühlerleitungen

4. INSTALLATION DRAWINGS

4.1 FM Installation Drawing 50016324

4.1.1 Model STT171-BS and STT17-BS

Hazardous (Classified) Location

Class I, Division 1, Groups, A, B, C, D
Class I, Zone 0, IIC

Ambient temperature limits
T4: -40 to + 85 deg. Celcius
T6: -40 to + 60 deg. Celcius

Terminal 1, 2
Vmax or Ui: 30 V
Imax or Ii: 120 mA
Pmax or Pi: 0.84 W
Ci: 1 nF
Li: 10 uH

Terminal 3, 4, 5, 6
Only passive, or non-energy storing devices such as RTD's and Thermocouples may be connected.

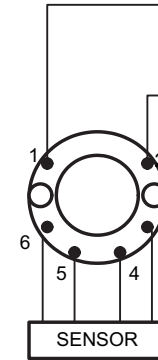

Non Hazardous Location

Associated Apparatus or Barrier with entity Parameters:

$UM \leq 250V$
 $Voc \text{ or } Uo \leq Vmax \text{ or } Ui$
 $Isc \text{ or } Io \leq Imax \text{ or } Ii$
 $Po \leq Pi$
 $Ca \text{ or } Co \geq Ci + Ccable$
 $La \text{ or } Lo \geq Li + Lcable$

This device must not be connected to any associated apparatus which uses or generates more than 250 VRMS

Figure 4-1 Model STT171-BS and STT173-BS [FM Installation Drawing]

4.1.2 The Entity Concept

The Transmitter must be installed according to National Electrical Code (ANSI-NFPA 70).

Equipment that is FM-approved for intrinsic safety may be connected to barriers based on the ENTITY CONCEPT. This concept permits interconnection of approved transmitters, meters and other devices in combinations which have not been specifically examined by FM, provided that the agency's criteria are met. The combination is then intrinsically safe, if the entity concept is acceptable to the authority having jurisdiction over the installation.

The entity concept criteria are as follows:

The intrinsically safe devices, other than barriers, must not be a source of power.

The maximum voltage U_i (V_{max}) and current I_i (I_{max}), and maximum power P_i (P_{max}), which the device can receive and remain intrinsically safe, must be equal to or greater than the voltage (U_o or V_{OC} or V_t) and current (I_o or I_{SC} or I_t) and the power P_o which can be delivered by the barrier.

The sum of the maximum unprotected inductance (L_i) for each intrinsically device and the interconnecting wiring must be less than the inductance (L_a) which can be safely connected to the barrier.

The entity parameters U_o , V_{OC} or V_t and I_o , I_{SC} or I_t , and C_a and L_a for barriers are provided by the barrier manufacturer.

4.2 CSA Installation Drawing 50016326

4.2.1 Model STT171-BS, STT173-BS and STT17H-BS

Model STT171-BS, STT173-BS and STT17H-BS transmitters are approved as intrinsically safe in Zone 0 Group IIC or Class I, Division 1, Group A,B,C,D when installed according to this Installation Drawing.

1. Connections with separate power supply and receiver.

Output: Standard 4 - 20 mA loop

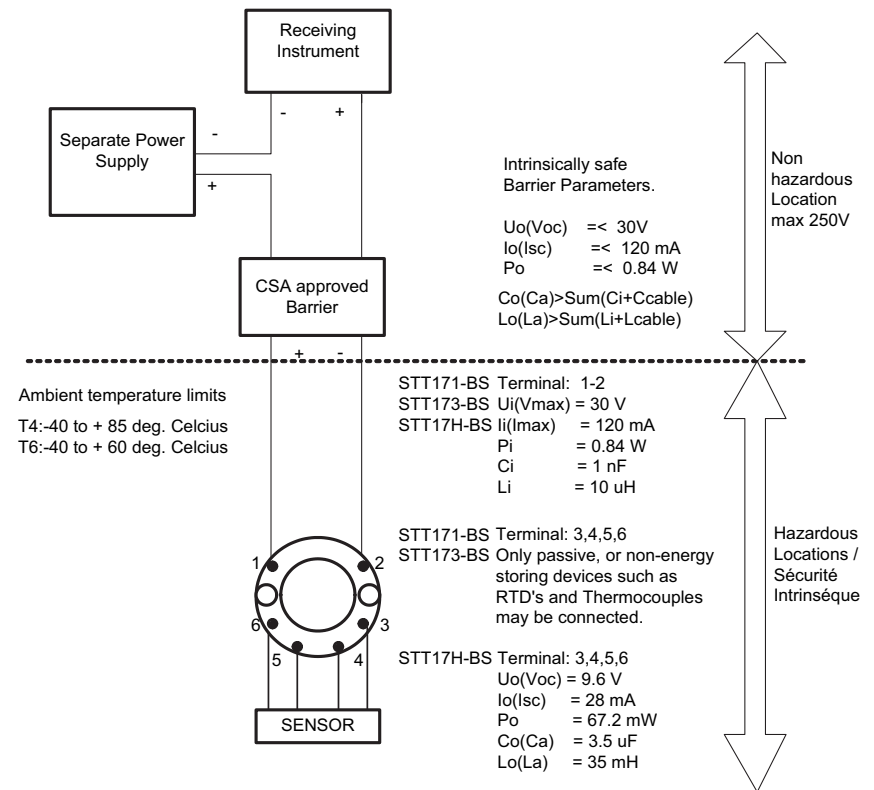

Warning:

Substitution of components may impair intrinsic safety.

The transmitters must be installed in a suitable enclosure to meet installation codes stipulated in the Canadian Electrical Code (CEC).

Figure 4-2 Model STT171-BS, STT173-BS and STT17H-BS [Connections with separate power supply and receiver]

2. Connections with power supply and barrier built into receiver.

Output: Standard 4 - 20 mA loop

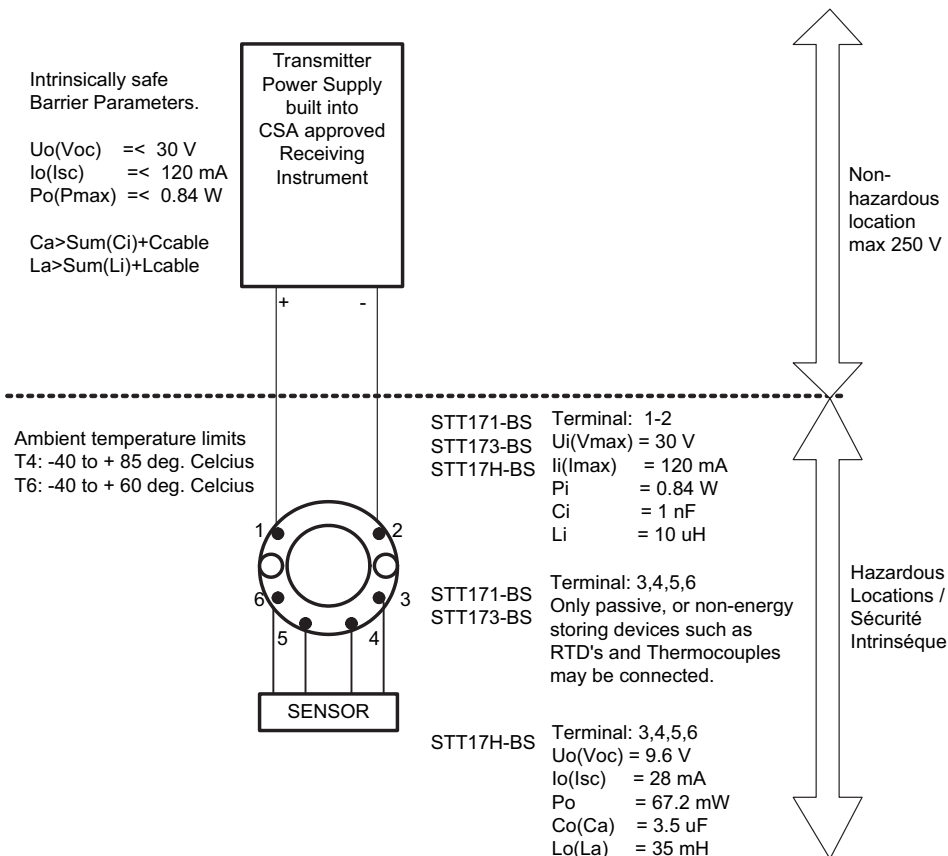

Warning:

Substitution of components may impair intrinsic safety.
 The transmitters must be installed in a suitable enclosure to meet installation codes stipulated in the Canadian Electrical Code (CEC).

Figure 4-3 Model STT171-BS, STT173-BS and STT17H-BS [Connections with power supply and barrier built into receiver]

4.3 ATEX Installation Data

EEx / I.S. approval STT171-BS:

KEMA 06ATEX0042 X..... Ex II 1 GD, T80°C...T105°C
 EEx ia IIC T6 / T4
 Max. amb. temp. for T1...T4 85°C
 Max. amb. temp. for T5 and T6 60°C
 ATEX, applicable in zone..... 0, 1, 2, 20, 21 or 22

Ex / I.S. data:

Signal output / supply, terminal 1 and 2:

U_i : 30 VDC
 I_i : 120 mADC
 P_i : 0.84 W
 L_i : 10 μH
 C_i : 1.0 nF

Sensor input, terminal 3, 4 and 6:

U_o : 27 V
 I_o : 7 mA
 P_o : 45 mW
 L_o : 35 mH
 C_o : 90 nF

5. DECLARATION OF CONFORMITY

We declare under our sole responsibility that the following product in the STT 3000 Temperature Transmitter series:

STT171 Smart Temperature Transmitter

is in conformity with the following directives and standards:

EMC directive 2004/108/EC and later amendments

EN 61326

This declaration is issued in compliance with article 10, subclause 1 of the EMC directive. For specification of the acceptable EMC performance level, refer to the electrical specifications for the module.

The ATEX directive 94/9/EC and later amendments

EN 50014 and EN 50020

EN 50281-1-1 and EN 50284

ATEX certificate: KEMA 06ATEX0042 X (STT171-BS)

Honeywell Industrial Solutions

2500 West Union Hills Drive
Phoenix, Arizona 85027 USA

Honeywell International Inc.

Industrial Measurement & Control
1100 Virginia Drive
Fort Washington, PA 19034 USA



Frederick M. Kent
Product Safety & Approvals Engineering
Issue Date: 21 March 2006



Honeywell

AUTHORIZED DISTRIBUTOR

De Gidts & Feldman BV
The Netherlands
w w w . d g f g . n l



De Gidts & Feldman

INSTRUMENTATION & FILTRATION

Honeywell International, Inc.
Industrial Measurement and Control
2500 W. Union Hills Drive
Phoenix, Arizona 85027
34-ST-25-25 - 0206
www.honeywell.com/imc

Honeywell
