

**STT700 SmartLine
Temperature Transmitter
User's Manual**

**34-TT-25-17
Revision 1
July 2017**

Copyrights, Notices and Trademarks

© Copyright 2017 by Honeywell, Inc.

Revision 1, July 2017

While the information in this document is presented in good faith and believed to be accurate, Honeywell disclaims any implied warranties of merchantability and fitness for a particular purpose and makes no express warranties except as may be stated in the written agreement with and for its customers. In no event is Honeywell liable to anyone for any indirect, special, or consequential damages. The information and specifications in this document are subject to change without notice.

Honeywell, TDC 3000, SFC, SmartLine, PlantScape, Experion PKS, and TotalPlant are registered trademarks of Honeywell International Inc. Other brand or product names are trademarks of their respective owners.

**Honeywell Process Solutions
1250 W Sam Houston Pkwy S
Houston, TX 77042**

About This Manual

This manual is a detailed *how to* reference for installing, piping, wiring, configuring, starting up, operating, maintaining, calibrating, and servicing Honeywell's family of STT700 temperature transmitters. Users who have a Honeywell STT700 SmartLine Temperature Transmitter configured for HART protocol or Honeywell's Digitally Enhanced (DE) are referred to the *STT700 SmartLine Series HART/DE Option User's Manual*, document number 34-TT-25-18.

The configuration of your transmitter depends on the mode of operation and the options selected for it with respect to operating controls, displays and mechanical installation. This manual provides detailed procedures to assist first-time users, and it further includes keystroke summaries, where appropriate, as quick reference or refreshers for experienced personnel.

To digitally integrate a transmitter with one of the following systems:

- For the Experion PKS, you will need to supplement the information in this document with the data and procedures in the *Experion Knowledge Builder*.
- For Honeywell's TotalPlant Solutions (TPS), you will need to supplement the information in this document with the data in the *PM/APM SmartLine Transmitter Integration Manual*, which is supplied with the TDC 3000 book set. (TPS is the evolution of the TDC 3000).

Release Information:

STT700 SmartLine Temperature Transmitter User Manual, Document # 34-TT-25-17,

Rev.1

July 2017

1st Release

References

The following list identifies publications that may contain information relevant to the information in this document.

- *STT700 SmartLine Temperature Transmitter Quick Start Installation Guide*, Document # 34-TT-25-19
- *STT700 SmartLine Temperature Transmitter HART/DE Option User's Manual*, Document # 34-TT-25-18
- *STT700 SmartLine Temperature Field Device Spec (HART)*, Document # 34-TT-00-05
- *STT700 SmartLine Transmitter Safety manual* Document # 34-TT-25-20
- *MC Toolkit User Manual*, MCT404, Document # 34-ST-25-50
- *Engineering Meter (EU) User Guide*, Document #34-ST-25-18
- *STT700 Series Temperature, Transmitter, Agency IS Control Drawing #50133855*
- *Smart Field Communicator Model STS 103 Operating Guide*, Document # 34-ST-11-14 (for use with STT700 DE only)

Patent Notice

The Honeywell STT700 SmartLine Temperature Transmitter family is covered by one or more of the following U. S. Patents: 5,485,753; 5,811,690; 6,041,659; 6,055,633; 7,786,878; 8,073,098; and other patents pending.

Support and Contact Information

For Europe, Asia Pacific, North and South America contact details, refer to the back page of this manual or the appropriate Honeywell Solution Support web site:

Honeywell Corporate www.honeywell.com

Honeywell Process Solutions <https://www.honeywellprocess.com>

SmartLine Temperature <https://www.honeywellprocess.com/smartline-temperature.aspx>











Training Classes <http://www.automationcollege.com>



Telephone and Email Contacts

Area	Organization	Phone Number
United States and Canada	Honeywell Inc.	1-800-343-0228 Customer Service 1-800-423-9883 Global Technical Support
Global Email Support	Honeywell Process Solutions	ask-ssc@honeywell.com

Symbol Descriptions and Definitions

The symbols identified and defined in the following table may appear in this document.

Symbol	Definition
	ATTENTION: Identifies information that requires special consideration.
	TIP: Identifies advice or hints for the user, often in terms of performing a task.
CAUTION	Indicates a situation which, if not avoided, may result in equipment or work (data) on the system being damaged or lost, or may result in the inability to properly operate the process.
	CAUTION: Indicates a potentially hazardous situation which, if not avoided, may result in minor or moderate injury. It may also be used to alert against unsafe practices. CAUTION symbol on the equipment refers the user to the product manual for additional information. The symbol appears next to required information in the manual.
	WARNING: Indicates a potentially hazardous situation, which, if not avoided, could result in serious injury or death. WARNING symbol on the equipment refers the user to the product manual for additional information. The symbol appears next to required information in the manual.
	WARNING, Risk of electrical shock: Potential shock hazard where HAZARDOUS LIVE voltages greater than 30 Vrms, 42.4 Vpeak, or 60 VDC may be accessible.
	ESD HAZARD: Danger of an electro-static discharge to which equipment may be sensitive. Observe precautions for handling electrostatic sensitive devices.
	Protective Earth (PE) terminal: Provided for connection of the protective earth (green or green/yellow) supply system conductor.
	Functional earth terminal: Used for non-safety purposes such as noise immunity improvement. NOTE: This connection shall be bonded to Protective Earth at the source of supply in accordance with national local electrical code requirements.
	Earth Ground: Functional earth connection. NOTE: This connection shall be bonded to Protective Earth at the source of supply in accordance with national and local electrical code requirements.
	Chassis Ground: Identifies a connection to the chassis or frame of the equipment shall be bonded to Protective Earth at the source of supply in accordance with national and local electrical code requirements.
continued	

Symbol	Description
	<p>The Factory Mutual® Approval mark means the equipment has been rigorously tested and certified to be reliable.</p>
	<p>The Canadian Standards mark means the equipment has been tested and meets applicable standards for safety and/or performance.</p>
	<p>The Ex mark means the equipment complies with the requirements of the European standards that are harmonized with the 94/9/EC Directive (ATEX Directive, named after the French "ATmosphere EXplosible").</p>

Contents

1.	Introduction	1
1.1.	Overview	1
1.2.	Features and Options	1
1.2.1.	Physical Characteristics	2
1.2.2.	Functional Characteristics	3
1.3.	STT700 SmartLine transmitter nameplate	3
1.4.	Safety Certification Information.....	4
1.5.	Transmitter Adjustments	4
1.6.	EU Meter Option – HART only	4
2.	Application Design.....	5
2.1.	Overview	5
2.2.	Safety.....	5
2.2.1.	Accuracy.....	5
2.2.2.	Diagnostic Messages	5
3.	Installation and Startup.....	9
3.1.	Installation Site Evaluation.....	9
3.2.	Honeywell MC Toolkit.....	9
3.3.	Mounting	10
3.3.1.	DIN Rail Mounting.....	10
3.3.2.	Mounting Module in Housing	11
3.3.3.	Uninstalling/Installing EU Meter from Housing	13
3.3.4.	Spring Loading	15
3.4.	Wiring a transmitter.....	16
3.4.1.	Loop Power Overview.....	16
3.4.2.	Digital System Integration Information.....	18
3.4.3.	Wiring Variations	18
3.4.4.	Grounding and Lightning Protection	19
3.4.5.	Input Sensor Wiring	20
3.4.6.	Lightning Protector.....	21
4.	Startup	24
4.1.1.	Overview	24
4.1.2.	Startup Tasks	24
4.1.3.	Output Check Procedures	24
4.1.4.	Constant Current Source Mode Procedure	25
5.	Operation	26
5.1.	Overview	26
5.2.	Configuration Tools.....	26
5.2.1.	Smart Field Communicator (SFC) for DE Models.....	26
5.2.2.	HART Communicator Model 375, 475 or MC Toolkit FDC for HART 7 Models	27
6.	Maintenance	29
6.1.	Overview	29
6.2.	Preventive Maintenance Practices and Schedules	29
6.3.	Troubleshooting.....	29
6.3.1.	Troubleshooting with SFC	29
6.3.2.	Troubleshooting with HART communicator.....	31
6.4.	Recommended Parts	32
6.5.	Wiring and Installation Drawings.....	34

7. Calibration.....	35
7.1. Recommendations for transmitter Calibration	35
7.2. Calibration Procedures	35
Appendix A. PRODUCT CERTIFICATIONS	36
Glossary	52

List of Figures

Figure 1 – STT700 HART Transmitter module.....	2
Figure 2- STT700 DE Transmitter module	2
Figure 3 – Nameplate on the side of the transmitter	3
Figure 4 –STT700 Model Number Format	3
Figure 5: DIN Rail Mounting.....	10
Figure 6: Wall Mounting Dimensions	11
Figure 7: Pipe Mounting Dimensions	12
Figure 8: Spring Loading and Sensor Assembly	15
Figure 9 – STT700 with HART Transmitter Operating Ranges.....	16
Figure 10– STT700 with DE Transmitter Operating Ranges	16
Figure 11 –STT700 module terminal connections.....	17
Figure 12 – HART/DE Input Wiring Diagram for single sensor connection	20
Figure 13 – Wiring Diagram for HART Dual Sensor Connections.....	20
Figure 14 – STT700 with Lightning Protector Dimensions.....	21
Figure 15 – Installation without EU Meter	22
Figure 16 – Installation with EU Meter	23
Figure 17 – Current Loop Test Connections.....	25

List of Tables

Table 1 – Features and Options	1
Table 2 – Available EU Meter Characteristics	4
Table 3 – STT700 Diagnostic Messages.....	6
Table 4 – STT700 Standard Non-Critical Diagnostics Messages.....	6
Table 5 - Dimension table for use with Figure 6 and Figure 7	12

1. Introduction

1.1. Overview

This section is an introduction to the physical and functional characteristics of Honeywell's STT700 SmartLine Temperature Transmitter.

1.2. Features and Options

The STT700 SmartLine Temperature Transmitter is available in a variety of models for measuring Thermocouples, RTD, Millivolts, and ohm sensor types. [Table 1](#) lists the protocols, Human-Machine Interface (HMI), materials, approvals, and mounting bracket options for the STT700.

Table 1 – Features and Options

Feature/Option	Standard/Available Options
Communication Protocols	HART version 7 Digitally Enhanced (DE)
Human-Machine Interface (HMI)	No Display
Options	EU Meter
Calibration	Single
Approvals (See Appendix A for details.)	ATEX, CSA, FM, IEC Ex
Mounting Brackets	Pipe mounting and wall mounting brackets in carbon steel and 316 stainless steel.
Integration Tools	DD or DTM Hosts such as Experion and FDM

1.2.1. Physical Characteristics

As shown in [Figure 1](#) and [Figure 2](#), the STT700 is packaged in a single module. The elements in this module are connected to the process sensors, measure the process variables, respond to setup commands and execute the software and protocol for the different temperature measurement types.

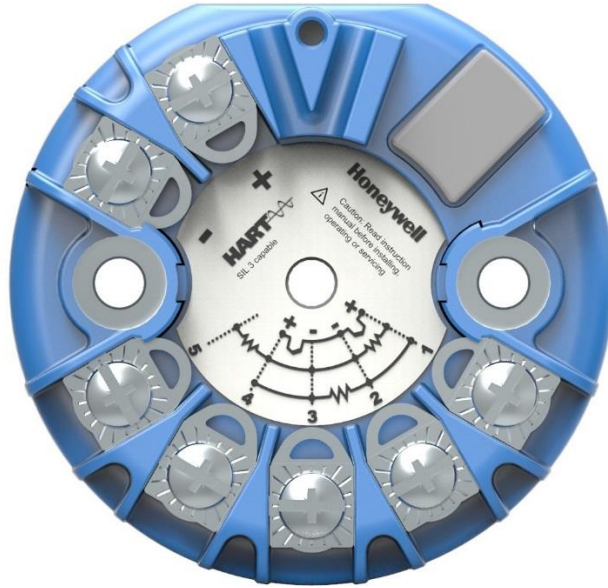

Figure 1 – STT700 HART Transmitter module



Figure 2- STT700 DE Transmitter module

1.2.2. Functional Characteristics

The transmitter measures process temperature and outputs a signal proportional to the measured process variable (PV). Available output communication protocols include 4 to 20mA, Honeywell Digitally Enhanced (DE) and HART protocols.

In addition, a Honeywell Multi-Communication (MC) Toolkit (not supplied with the transmitter) can facilitate setup and adjustment procedures in the case of HART and DE. Certain adjustments can be made through an Experion Station or a Universal Station if the transmitter is digitally integrated with Honeywell’s Experion or TPS/TDC 3000 control system for HART and DE transmitters.

1.3. STT700 SmartLine transmitter nameplate

The transmitter nameplate mounted on the side of the transmitter (see Figure 3) lists its model number, physical configuration, electronics options, accessories, certifications, and manufacturing specialties.



Figure 3 – Nameplate on the side of the transmitter

Figure 4 is an example of a typical temperature transmitter nameplate. The model number format consists of a Key Number with several table selections.

Key	I	II	III	IV	V	VI	VII	VIII
STT700	-	-	-	-	-	-	-	-00000

Figure 4 –STT700 Model Number Format

The transmitter type can be identified from the key number. The third letter in the Key number represents this basic transmitter type:

- T = Temperature

For a complete selection breakdown, refer to the appropriate Specification and Model Selection Guide provided as a separate document.

1.4. Safety Certification Information

The hazardous area approvals information is listed on the nameplate which, as shown in Figure 3, is located at the bottom of the module. The approvals nameplate contains information and service marks that disclose the transmitter compliance information. Refer to Appendix A of this document for safety certification requirements and details.

1.5. Transmitter Adjustments

For HART and DE you can use the Honeywell MC Toolkit or other third-party hand-held (for HART) to make any adjustments to an STT700 SmartLine Temperature Transmitter.

Any HART 7.0 compliant PC host like Honeywell FDM can be used to configure the device. Honeywell FDM can also configure the STT700 with DE protocol.

Alternately, certain adjustments can be made through the Experion or Universal Station, if the transmitter is digitally integrated with a Honeywell Experion or TPS system.

1.6. EU Meter Option – HART only

The STT700 SmartLine Temperature Transmitter can be supplied with the optional EU Meter, see [Table 2](#).



Table 2 – Available EU Meter Characteristics

EU Meter (HART only)	<ul style="list-style-type: none">• Compatibility for replacement of existing STT250 installations• 360° rotation in 90° increments• Standard units of measurement: °F, °C, °R, K, Ω, mV & %
-------------------------	--

2. Application Design

2.1. Overview

This section discusses the considerations involved with deploying a Honeywell STT700 SmartLine Temperature Transmitter in a process system. The following areas are covered:

- Safety
- Input and output data
- Reliability
- Environmental limits
- Installation considerations
- Operation and maintenance
- Repair and replacement

2.2. Safety

2.2.1. Accuracy

The STT700 SmartLine Temperature Transmitter accurately measures the temperature of a process and reports the measurement to a receiving device like a controller I/O module. Refer to STT700 Specification, 34-TT-03-19, for complete accuracy specifications.

2.2.2. Diagnostic Messages

The transmitter standard diagnostics are reported in the two basic categories: critical and non-critical faults. Problems detected as critical diagnostics drive the analog output to the programmed burnout level for HART and DE. Tables 3 and 4, below, list the diagnostics and how faults are handled by the STT700 transmitter. Refer to the Troubleshooting section for further details.

Table 3 show specific diagnostics to the transmitter, exclusive of those associated with HART and DE protocols. HART and DE diagnostic messages are listed and described in the *STT700 SmartLine Temperature Transmitter HART/DE Option User Manual*, document number 34-TT-25-18.

See Safety Integrity Level (SIL)

STT700 is intended to achieve sufficient integrity against systematic errors by the manufacturer's design. A Safety Instrumented Function (SIF) designed with this product must not be used at a SIL level higher than the statement, without "prior use" justification by the end user or diverse technology redundancy in the design. Refer to the *STT700 Safety Manual*, 34-TT-25-20, for additional information. The DE variant of STT700 is not SIL certified.

Table 3 – STT700 Diagnostic Messages

Critical Diagnostics (Failure Conditions)	Description	Details
Elec. Mod. Diag Failure	Diagnostics failure (like ROM / RAM corrupt etc.)	Action: Reset the device. If the problem persists replace the electronics module Note: Select "Device Status - Additional Status" to see which of these conditions are set.
Elec. Mod. DAC Failure	Failure related to DAC which regulates 4-20mA loop	Action: Reset the device. If problem persist, replace the electronics module. Note: Select "Device Status - Additional Status" to see which of these conditions are set.
Sensor Input Failure	Input sensor may be open / short / out of range	"Failure in sensing section. Any of the following conditions can cause this failure: 1..Input 1 Fault 2. Input 2 Fault. Check the sensor input connections. 3. Suspect Input. Check sensor and connections. If the connections are ok, and problem persists, replace the electronics module board Note: Select "Device Status - Additional Status" to see which of these conditions are set
Char/Cal Data Corrupt	Factory calibration data is corrupted	Characterization / Calibration data is corrupted or missing. Replace device if error persists upon power cycle
Config Data corrupt	NVM data corrupted	Action: Power cycle the device. If the problem persists, replace the electronics module.

Table 4 – STT700 Standard Non-Critical Diagnostics Messages

Non-Critical Diagnostics (Warning Conditions)	Description	Details
CT Out of Range	MCU temperature of the device is out of range	Core Temperature out of range (-36°C to 112.5°C). If it is certain that the reading is in error, then contact the vendor.
No Factory Calibration	Factory calibration data is not available, device is not factory calibrated	The transmitter has not been calibrated by the factory. Contact the vendor.
PV Out of Range	Process value measured is out of range	Loop PV is out of configured URV and LRV. Check your process temperature. Adapt the span. Check range and, if required, replace transmitter with one that has a wider range.
CJ Out of Limits SV Bad	Cold junction sensor temperature or device terminal temperature is out of limits (-40°C to 85°C is the range)	The ambient temperature measured is out of the transmitter specifications (-40°C to 85°C). Take steps to isolate the device from the temperature source.

Sensor1 excess LRV correct	Applied Input 1 value and measured value differ by more than 1.5% span at low calibration point	This non critical flag will be set when difference between applied Input 1 LRV value and measured value exceeds 1.5% of span. Perform Reset correct.
Sensor1 excess URV correct	Applied Input 1 value and measured value differ by more than 1.5% span at high calibration point	This non critical flag will be set when difference between applied Input 1 URV value and measured value exceeds 1.5% of span. Perform Reset correct.
Suspect Input	MCU reference voltages are beyond limits and hence inputs measured may not be correct	MCU reference voltages are beyond limits and hence inputs measured may not be correct. Replace the sensor based on Input 1, Input 2 measurement suspect.
Fixed Current Mode	The 4-20mA loop is put in fixed current mode and is not following the PV value	Output current is fixed and not varying as per input. Loop current mode is disabled or Loop Test is active. Enable loop current mode if it is disabled or exit the Loop Test mode if active to return to normal operation.
Input1 Fault	Input1 may be open/short	There is a problem with the Input 1 sensor. Verify sensor connections and configuration.
Input2 Fault	Input2 may be open/short	There is a problem with the Input 2 sensor. Verify sensor connections and configuration.
Analog Output Saturated	This status is set when loop current is set to out of 4-20 mA (generally when PV is out of range)	Calculated analog output is either above or below the specified loop current limits. The transmitter input is not in specified range. Check the transmitter input.
Excess Delta Detect	Sensor 1 and Sensor 2 measured values differ by more than a user defined threshold	This will be set when delta value exceeds delta limit. When Excess Delta Alarm is disabled and device is in non-redundant mode, this status indicates that the difference between two sensor inputs has crossed the applicable delta limit
ADC Fault	ADC reference voltages are beyond working correct limits	Controller ADC fault. Replace device if error persists upon power cycle.
Sensor2 excess LRV correct	Applied Input 2 value and measured value differ by more than 1.5% span at low calibration point	This will be set when difference between applied Input 2 LRV value and measured value exceeds 1.5% of span
Sensor2 excess URV correct	Applied Input 2 value and measured value differ by more than 1.5% span at high calibration point	This will be set when difference between applied Input 2 URV value and measured value exceeds 1.5% of span
Input1 Out Of Range	Measured value of Sensor1 is out of range	Input 1 temperature is greater than Sensor 1 URL or less than Sensor 1 LRL Set when the input at first sensor is either under range or over range

Input2 Out Of Range	Measured value of Sensor2 is out of range	Input 2 temperature is greater than Sensor 2 URL or less than Sensor 2 LRL. Set when the input at second sensor is either under range or over range
Watchdog reset	Watchdog has reset (it may be due to FW failure or HW failure)	Controller Watchdog has reset
Supply Voltage Fault	MCU or DAC reference voltages are beyond limits	This is set when one of the supply voltages (DAC loop / MCU) in the device is outside its specification limits. Check the transmitter supply voltage
SIL Diagnostics	RAM / NVM database corrupt	Advance diagnostics data is corrupted. Power cycle the device

3. Installation and Startup

3.1. Installation Site Evaluation

Evaluate the site selected for the STT700 SmartLine transmitter installation with respect to the process system design specifications and Honeywell's published performance characteristics for your particular model and sensor selection. Some parameters that you may want to include in your site evaluation are:

- Environmental Conditions:
 - Ambient temperature
 - Relative humidity
- Potential Noise Sources:
 - Radio frequency interference (RFI)
 - Electromagnetic interference (EMI)
- Vibration Sources
 - Pumps
 - Motorized system devices (e.g., pumps)
 - Valve cavitation
- Process Parameters
 - Temperature
 - Maximum sensor input ratings

3.2. Honeywell MC Toolkit

In preparation for post-installation processes, refer to the *MC Toolkit User Manual (MCT404)*, Document # 34-ST-25-50, for device operation and maintenance information.

3.3. Mounting

3.3.1. DIN Rail Mounting

If the STT700 is to be installed on DIN rail option then the main considerations are electrical connections and mechanical fixing. Electrical connections are identical to the bench test instructions except that thermocouple wire is likely to be used with thermocouples. Mechanical fixing of the module is by means of the snap-in DIN rail clips which are screwed to the bottom lugs of the module.

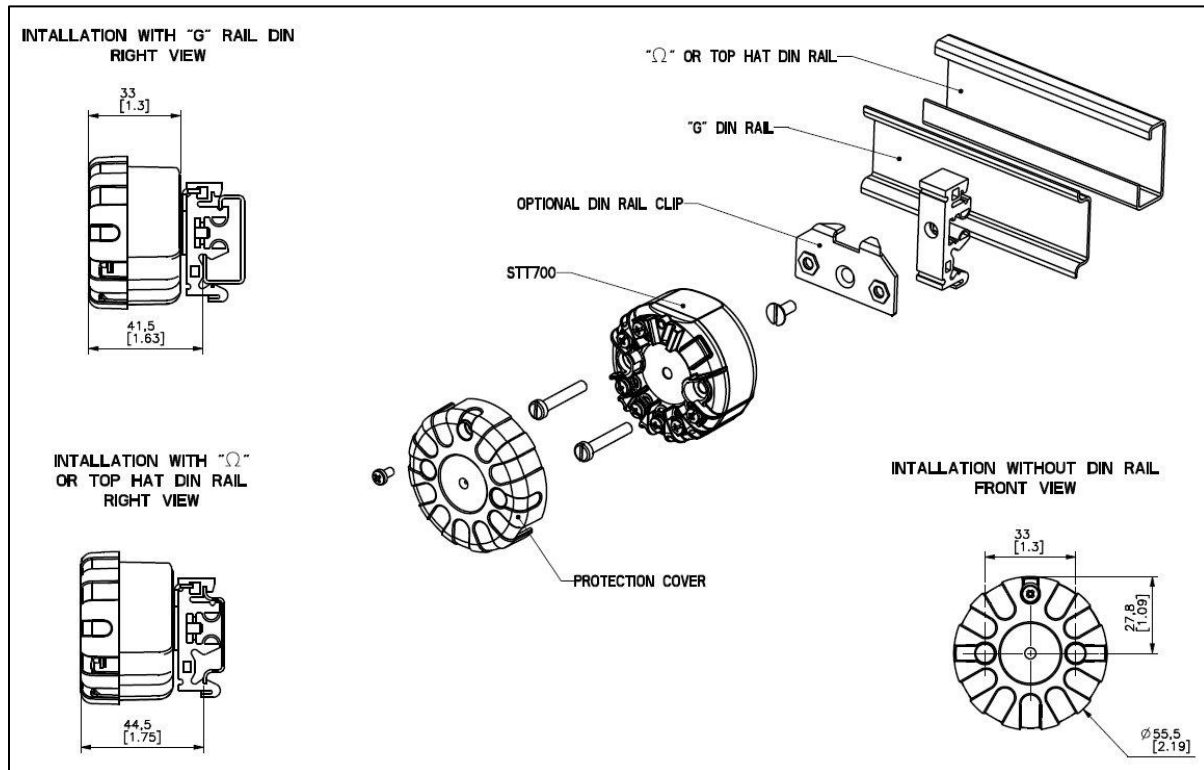

The DIN rail needs to be connected to Earth Ground per Section 0 below. It is generally required by regional wiring, safety and installation codes that these units be mounted in a suitable enclosure such as a metal cabinet or box which is locally connected to Earth Ground.

3.3.2. Mounting Module in Housing

The STT700 module can be installed in a variety of housings suitable for field mounting (2" or 50mm pipe mount), direct head mounting, or wall mounting.

Ensure that the installation location is suitable for reliable transmitter operation (e.g. for high temperature applications, a thermowell extension is recommended to minimize failure rates due to high ambient temperatures near the transmitter).

	<p>ATTENTION:</p> <p>THIS PRODUCT IS SUPPLIED WITH PLASTIC DUST PLUGS IN THE CONDUIT/CABLE GLAND ENTRIES. IT IS THE USER'S RESPONSIBILITY TO PROVIDE CABLE GLANDS, ADAPTORS AND/OR BLANKING PLUGS SUITABLE FOR THE ENVIRONMENT IN WHICH THIS PRODUCT IS INSTALLED. WHEN INSTALLED IN A HAZARDOUS LOCATION THE CABLE GLANDS, ADAPTORS AND/OR BLANKING PLUGS SHALL ADDITIONALLY BE SUITABLE FOR THE HAZARDOUS LOCATION, THE PRODUCT CERTIFICATION AND ACCEPTABLE TO THE AUTHORITY HAVING JURISDICTION FOR THE INSTALLATION.</p>
---	--

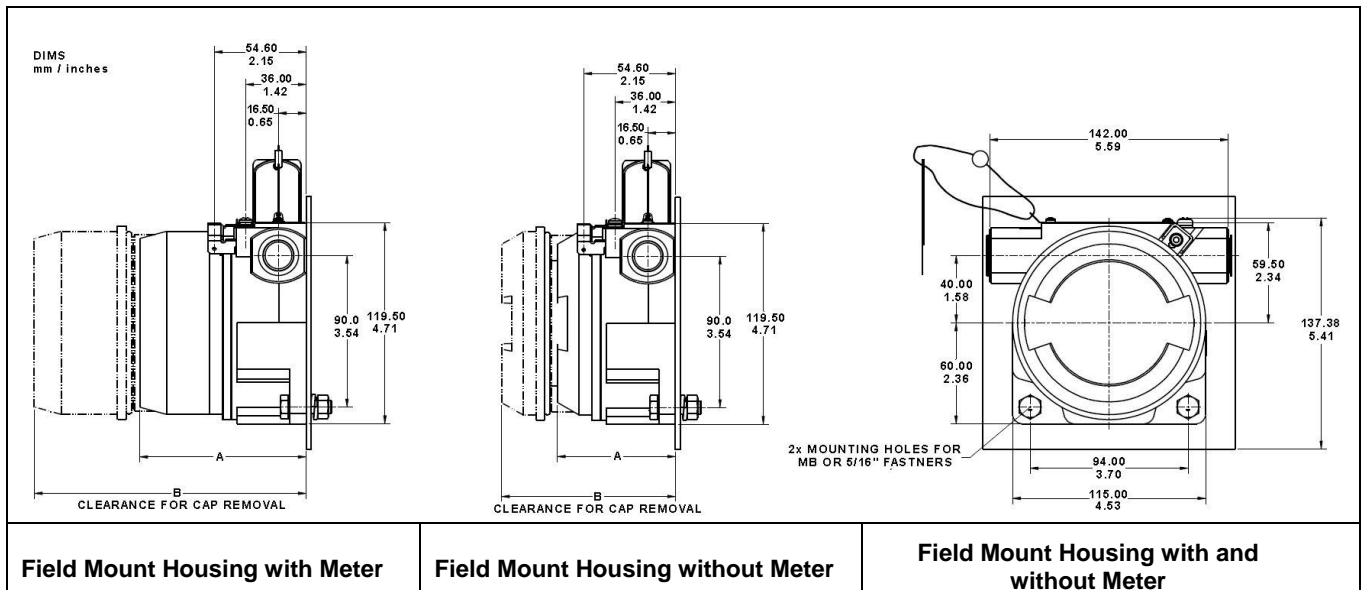

Figure 6: Wall Mounting Dimensions

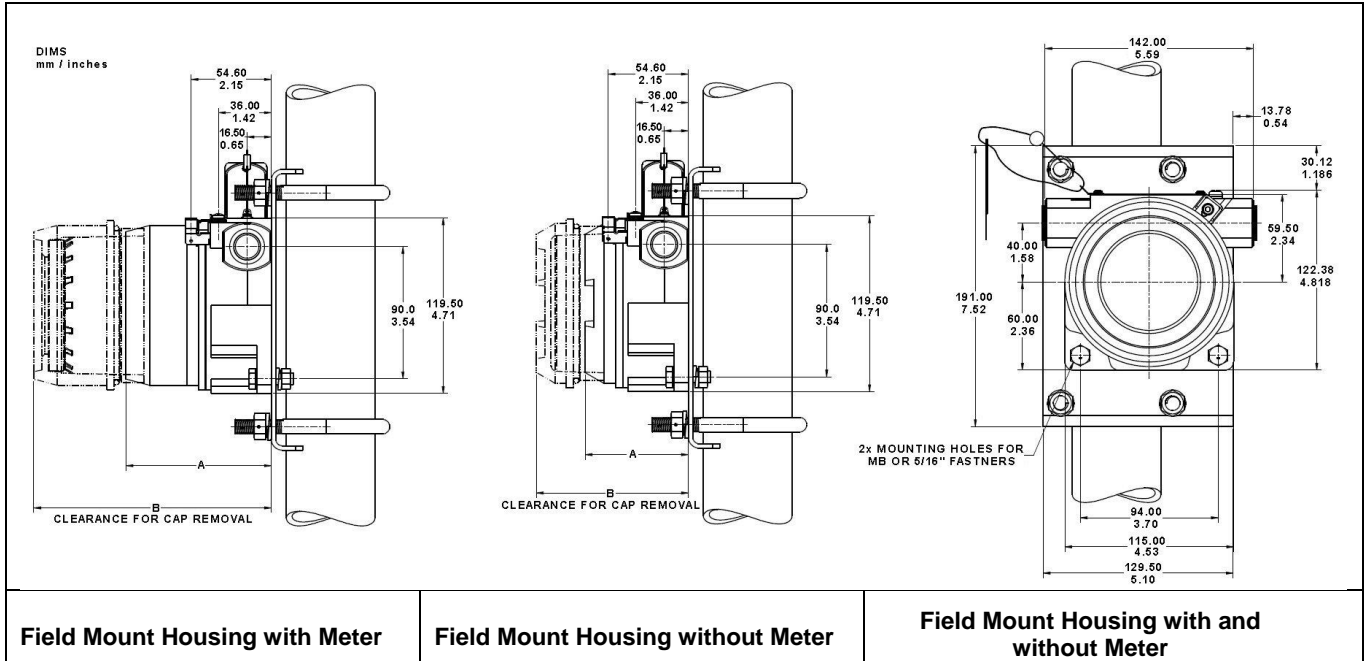

Figure 7: Pipe Mounting Dimensions

Table 5 - Dimension table for use with Figure 6 and Figure 7

Dimensions	Aluminum (field mount housing)	
	A	B
Without integral meter	70 mm [2.76 inch]	120,8 mm [4.76 inch]
With integral meter	127 mm [5.00 inch]	210,8 mm [8.30 inch]

3.3.3. Uninstalling/Installing EU Meter from Housing

EU Meter:

1. Remove the EU METER from the mounting bracket.
2. Unfasten the 2 mounting screws.
3. Remove the bracket.

To put the EU meter back follow the above sequence in the reverse order.

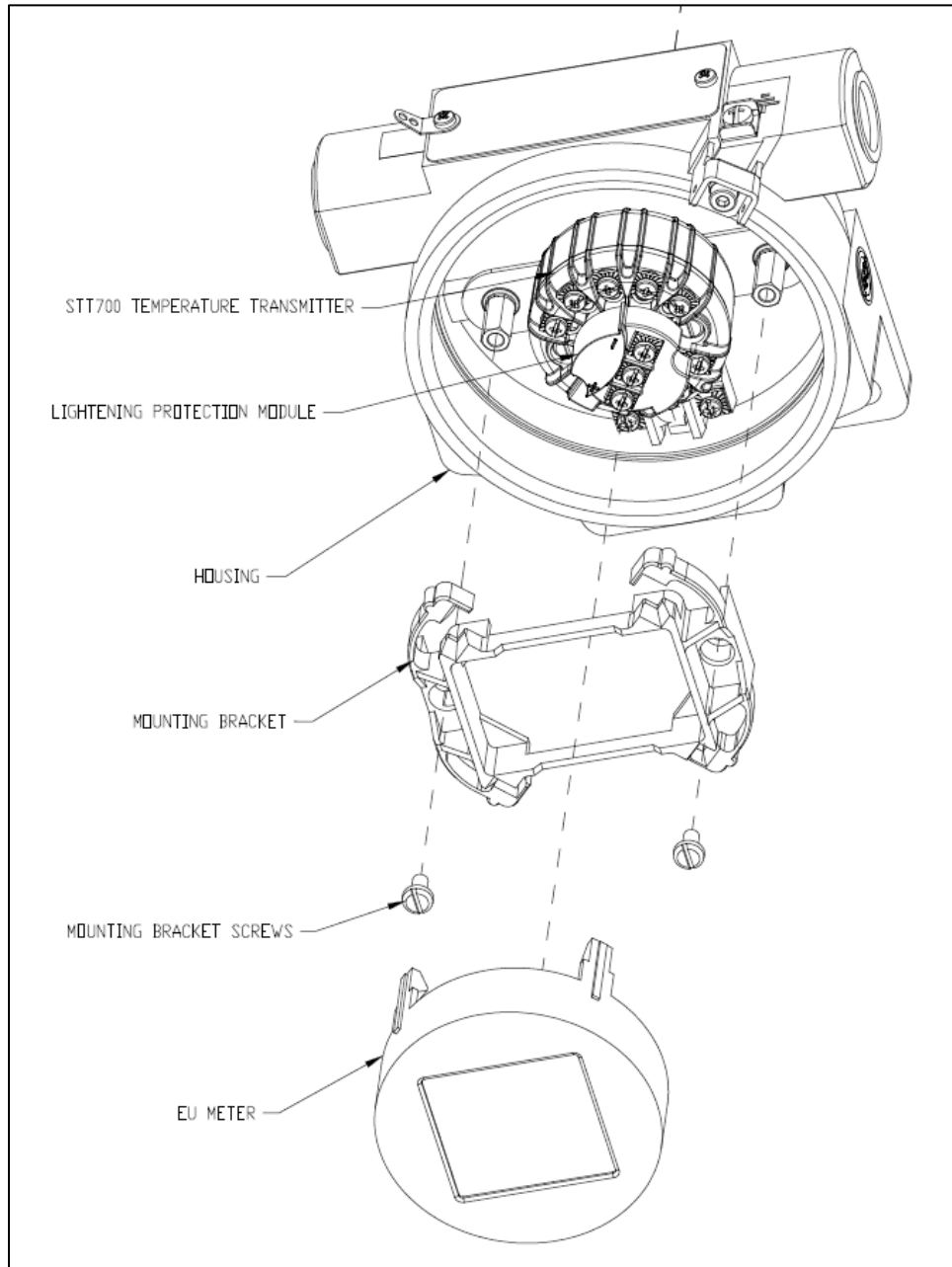

Housing Cover and O Ring:

1. Review O-ring condition & replace, if damaged. New O-ring can be ordered from spare parts list.
2. Apply O-ring lubricant to the end cap O-ring. Relax O-ring twists, if any.
3. Assemble housing cover with sufficient torque for securing against IP.

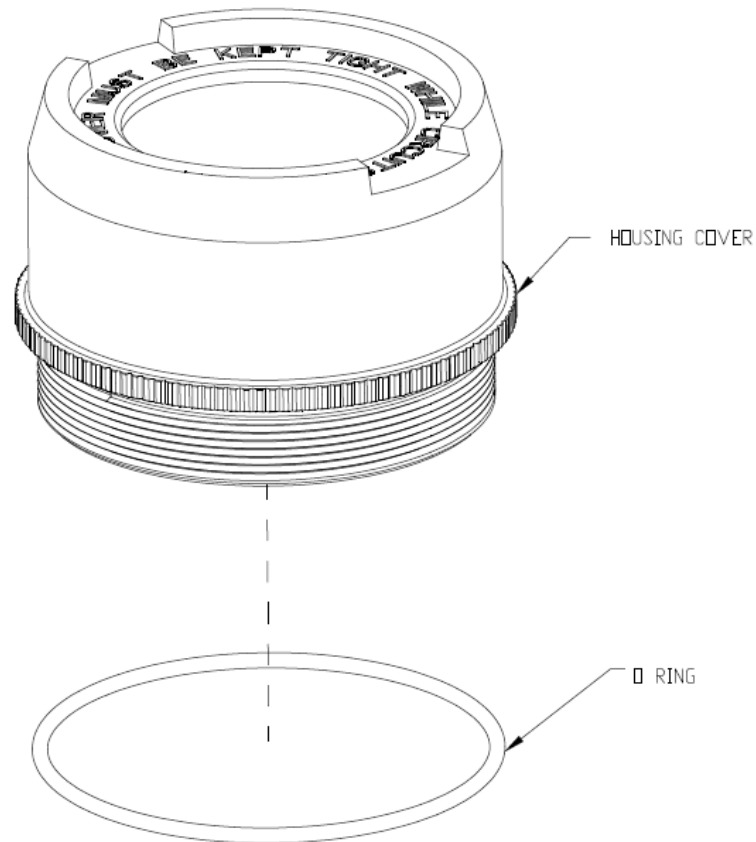

3.3.4. Spring Loading

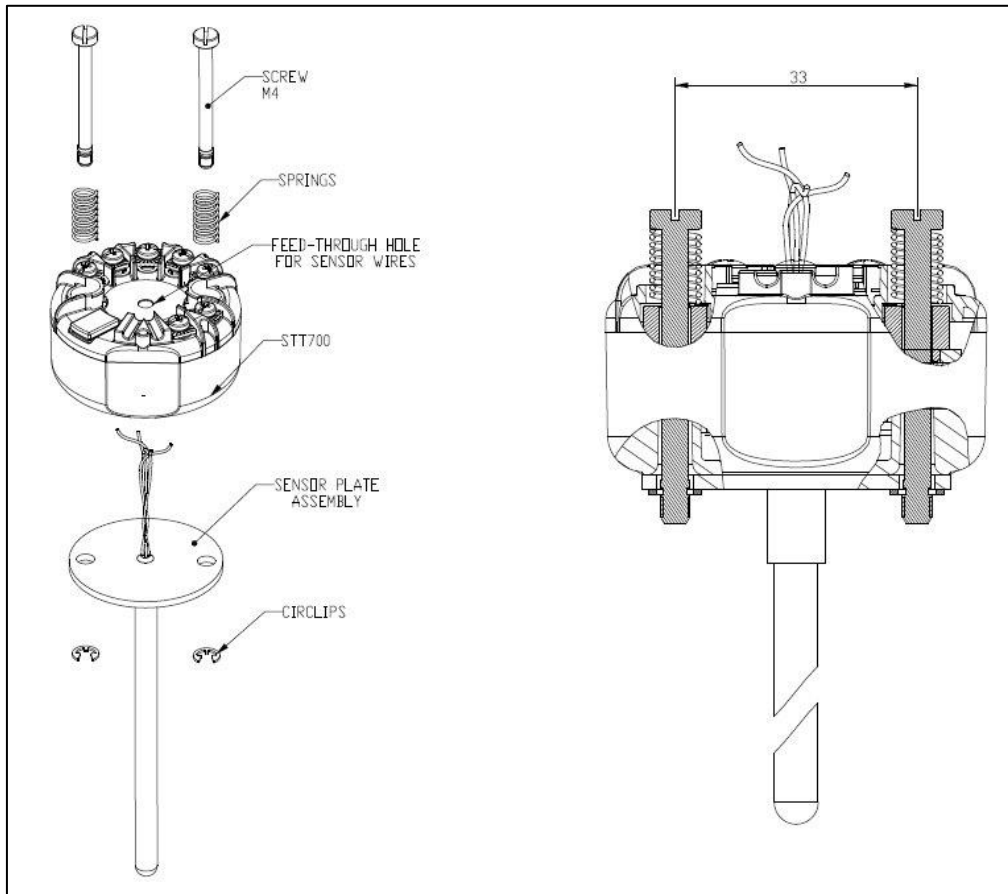

Figure 8: Spring Loading and Sensor Assembly

Spring loading is available worldwide with direct head mounting. In North America, the spring loading is typically included in the sensor/thermowell assembly and is available with all housings. For non-North American spring loading as shown in [Figure 8](#), simply include the springs under the 33 mm pitch mounting screws, pass the screws through the module and sensor mounting plate and snap in the retaining circlip to the screws to hold the assembly together. Guide the sensor assembly through the housing sensor entry and screw down the 33 mm screws until the limit is reached as the sensor presses against the bottom of thermowell.

For wall or 2" pipe mounting, the temperature sensor can be remote from the STT700 field mount housing or integral to the housing. For remote installations, the sensor wiring should be run in shielded, twisted pair wiring and connected via one of the housing wiring entries.

For explosion proof/flameproof installations, ensure that the cable entries are fitted with flameproof adaptors and that the wiring grade complies with local standards.

3.4. Wiring a transmitter

3.4.1. Loop Power Overview

The transmitter is designed to operate in a two-wire power/current loop with loop resistance and power supply voltage within the HART or DE operating range shown in Figure 9 and Figure 10.

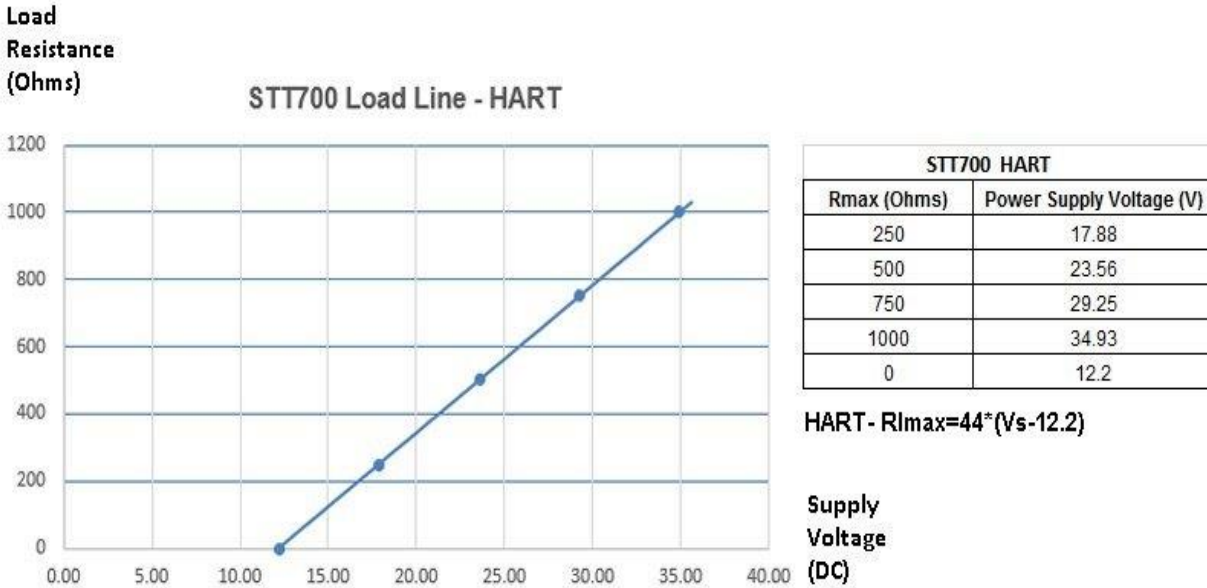

Figure 9 – STT700 with HART Transmitter Operating Ranges

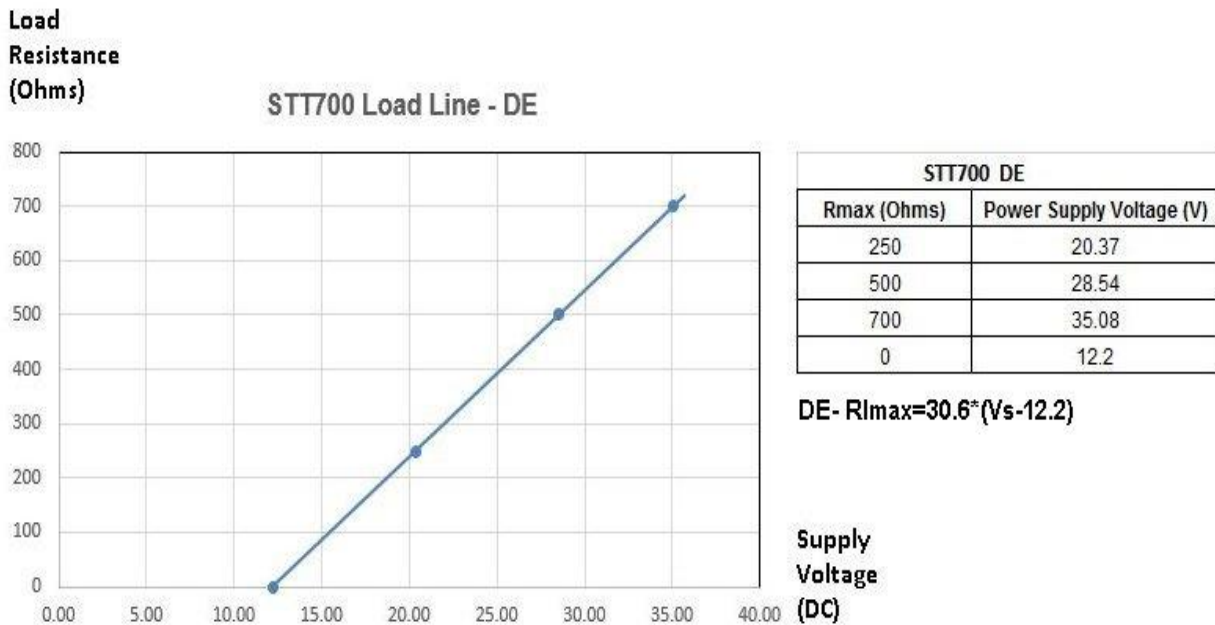

Figure 10– STT700 with DE Transmitter Operating Ranges

Loop wiring is connected to the transmitter by simply attaching the positive (+) and negative (-) loop wires to the positive (+) and negative (-) terminals on the transmitter module terminal block. Route the wires through the pre-moded channels on top of the terminal module. Connect the loop power wiring shield to Earth Ground only at the power supply end.

Note that the STT700 transmitter features SmartLine's Universal terminal wiring capability and thus is not polarity-sensitive.

With the single input HART transmitter, four (4) terminal screws will be available on the top of the module. When either the dual-input HART or the single input DE is supplied, five (5) termination screws will be included.

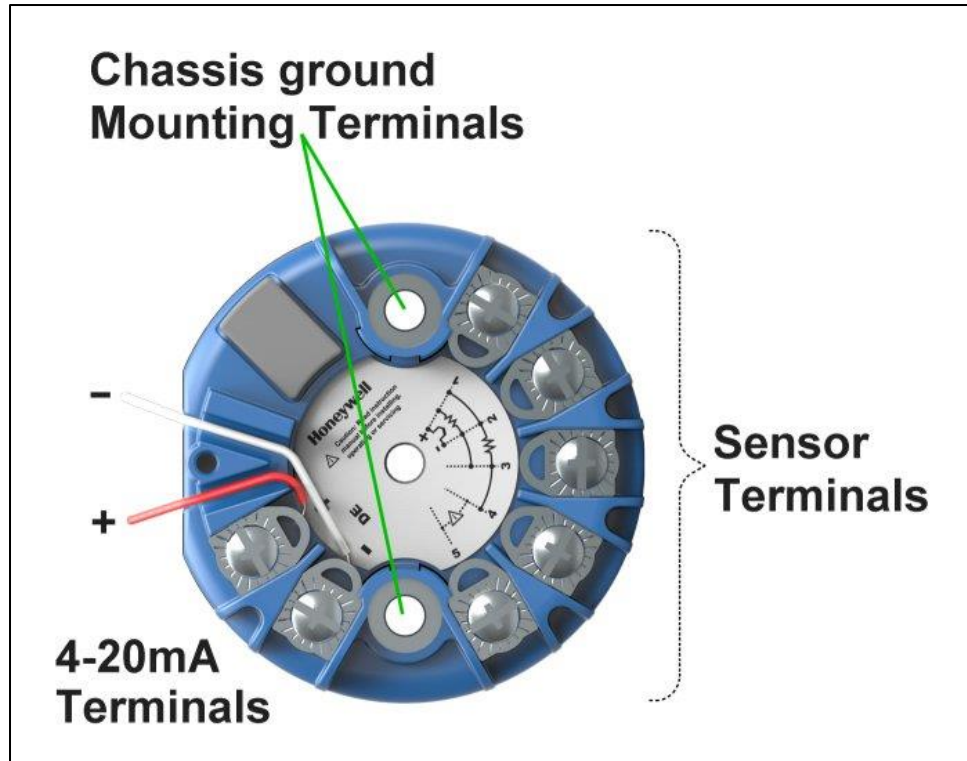

Figure 11 –STT700 module terminal connections

This transmitter uses the two mounting screws to connect it to Earth Ground. Grounding the transmitter for proper operation is required, as doing so tends to minimize the possible effects of noise on the output signal and affords protection against lightning and static discharge. An optional lightning protection module is available for use in areas that are highly susceptible to lightning strikes. As noted above, the loop power wiring shield should only be connected to Earth Ground at the power supply end.



Wiring must comply with local codes, regulations and ordinances.

The current output signal will operate a floating or ground system.

If the signal appears noisy or erratic, it is recommended to ground the loop at the negative terminal of the power supply.

Shielding should only be connected to ground at one point to avoid ground loops.

For HART and DE, the transmitter is designed to operate in a two-wire power/current loop with loop resistance and power supply voltage within the operating range; see Figure 9. With an optional remote meter, the voltage drop for this must be added to the basic power supply voltage requirements, to determine the required transmitter voltage (V_{XMTR}) and maximum loop resistance ($R_{LOOP\ MAX}$). Additional consideration is required when selecting intrinsic safety barriers to ensure that they will supply at least minimum transmitter voltage ($V_{XMTR\ MIN}$), including the required 250 ohms of resistance (typically within the barriers) needed for digital communications.

Transmitter loop parameters are as follows:

$R_{LOOP\ MAX}$ = maximum loop resistance (barriers plus wiring) that will allow proper transmitter operation and is calculated as $R_{LOOP\ MAX} = (V_{SUPPLY\ MIN} - V_{XMTR\ MIN} - V_{SM}) \div 21.8\ mA$.

In this calculation:

$$V_{XMTR\ MIN} = 10.8\ V$$

$$V_{SM} = 2.3\ V\ \text{if using EU or Remote meter, } 0V\ \text{if not using EU or Remote meter}$$

Note that V_{SM} should only be considered if an EU meter will be connected to the transmitter.

The positive and negative loop wires are connected to the positive (+) and negative (-) terminals on the STT700.

Barriers can be installed per Honeywell's instructions for transmitters to be used in intrinsically safe applications.

Note: Problems detected as non-critical diagnostics may affect performance without driving the analog output to the programmed burnout level (for HART only). For DE, the burnout direction needs to be selected in the hardware and this will be detected at power on time.

3.4.2. Digital System Integration Information

DE transmitters that are to be digitally integrated to Honeywell's Total Plant Solution (TPS) system will be connected to the temperature transmitter Interface Module in the Process Manager, Advanced Process Manager or High Performance Process Manager through a Field Termination Assembly. Details about the TPS system connections are given in the *PM/APM SmartLine Transmitter Integration Manual*, PM12-410, which is part of the TDC 3000^X system bookset.

When digitally integrating a transmitter in an Allen Bradley Programmable Logic Controller (PLC) process system, the same Field Terminal Assembly (FTA) and wiring procedures used with Honeywell's TPS system are also used with the Allen-Bradley 1771 and 1746 platforms.

3.4.3. Wiring Variations

The above procedures are used to connect power to a transmitter. For loop wiring, sensor wiring and external wiring, detailed drawings are provided for transmitter installation in non-intrinsically safe areas and for intrinsically safe loops in hazardous area locations.

If you are using the transmitter with Honeywell's TPS system, see *PM/APM SmartLine Transmitter Integration Manual*, PM12-410, which is part of the TDC 3000^X system bookset.

3.4.4. Grounding and Lightning Protection

Connect a wire from the mounting screws to Earth Ground to make the protection effective. Use size 14 AWG or 2.0mm² bare or green covered wire for this connection.

For ungrounded thermocouple, mV, RTD or ohm inputs, connect the input wiring shield(s) to the same Earth Ground connection.

For grounded thermocouple inputs, connect the internal ground connection shown in Figure 11 to the same Earth Ground as used by the thermocouple. For direct head mount housings, the ground terminal may not exist and another means of direct ground connection will need to be devised. For proper protection, the green ground wire must be securely connected to a local ground in as direct a path as possible. As noted above, the loop power wiring shield should only be connected to Earth Ground at the power supply end.



The tightening torque to be applied on the wire termination screws are to be between 0.34 Nm (3 in-lbf) min to 0.56 Nm (5 in-lbf) max.

Shielded twisted pair cable gauge 18AWG-22AWG for the sensor connections and 22AWG – 14AWG for the loop power connections.

The tightening torque to be applied on the STT700 module mounting screws are to be between 1.0 Nm (8.85 in-lbf) min to 1.35 Nm (12 in-lbf) max.

3.4.5. Input Sensor Wiring

Connect the input sensors as shown in Figures below for RTD, thermocouple, mV and ohm connections.

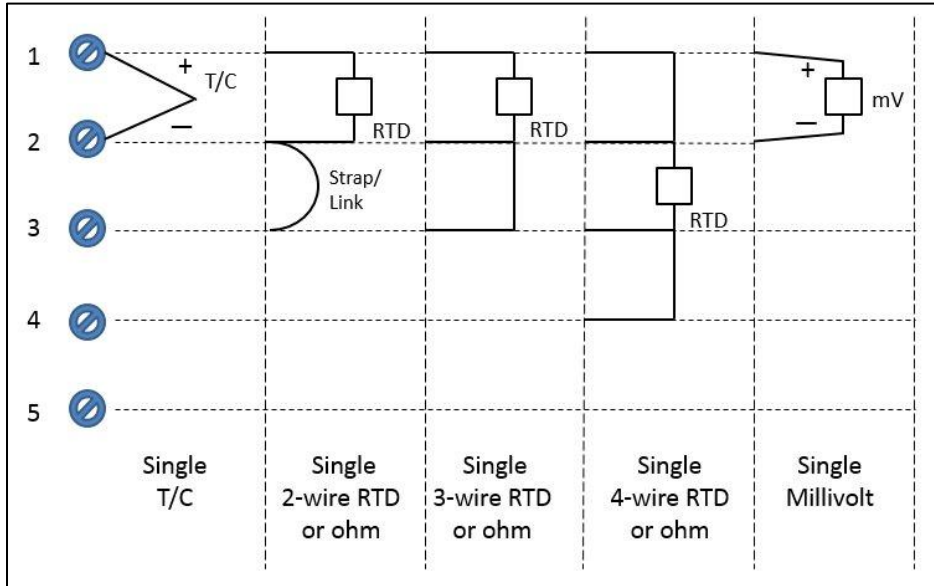

Figure 12 – HART/DE Input Wiring Diagram for single sensor connection

The single sensor connections can also be used on a dual input transmitter when a second input is not required. In this case, it is recommended that the second input be configured to **None** in the software. In case of RTD type being configured for 4-wire, the configuration for single input is automatically done.

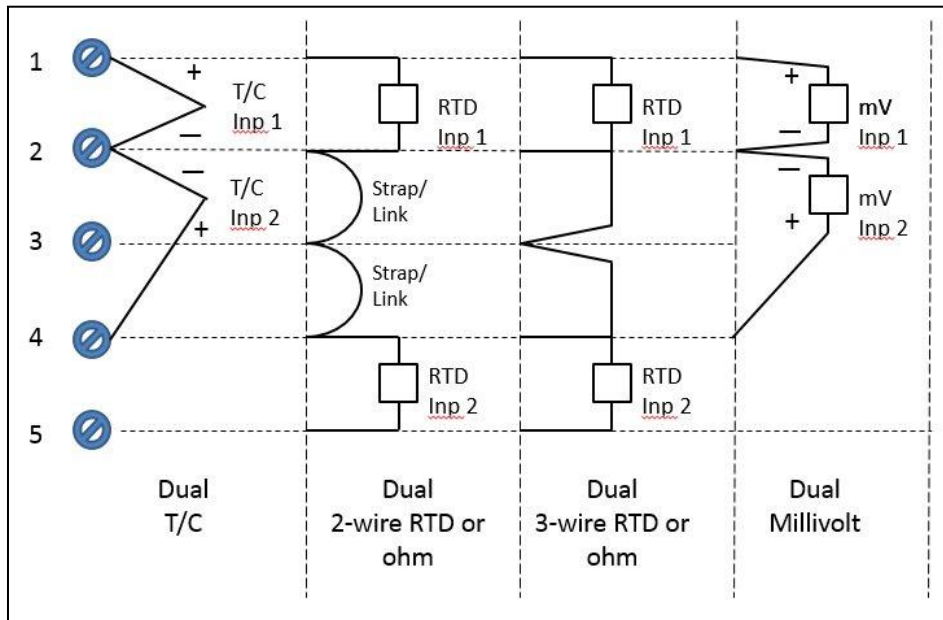

Figure 13 – Wiring Diagram for HART Dual Sensor Connections

3.4.6. Lightning Protector

The lightning protection device is designed to give the STT700 temperature transmitter maximum protection against surges such as those generated by lightning strikes. It mounts on the top of the STT700 transmitter module, providing easy field wiring and also protection for the EU meter if used.

The compact mounting allows the use of a variety of housings including the Honeywell explosion proof field mount housing.

The device can be used in both intrinsic safety and flame/explosion proof applications.

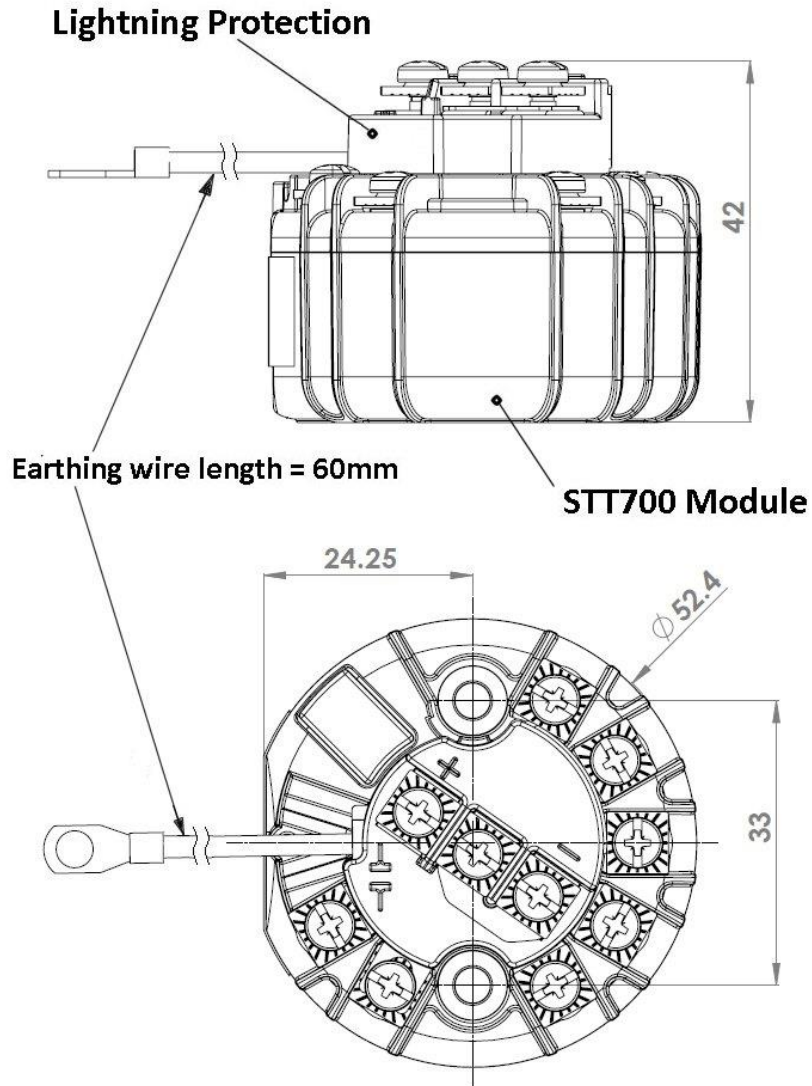

Figure 14 – STT700 with Lightning Protector Dimensions

3.4.6.1. Installation

- If an EU meter is used, remove the shunt on the Lightning Protector. In all other cases, the shunt must be present.
- Remove the cover/cap of the housing (if applicable). The device fits on the top of the transmitter module terminal block and the transmitter output screws (+ and -) fix mechanically the device.
- Attach the grounding wire to the ground screw in the housing. Connect a wire from the transmitter enclosure to local Earth Ground. Use size 14 AWG or 2.0mm² bare or green covered wire.
- If an EU meter is used, wire according to Figure 16.
- Connect the 4 – 20mA loop to the + and – terminal screws of the surge protection and close the cap of the housing.

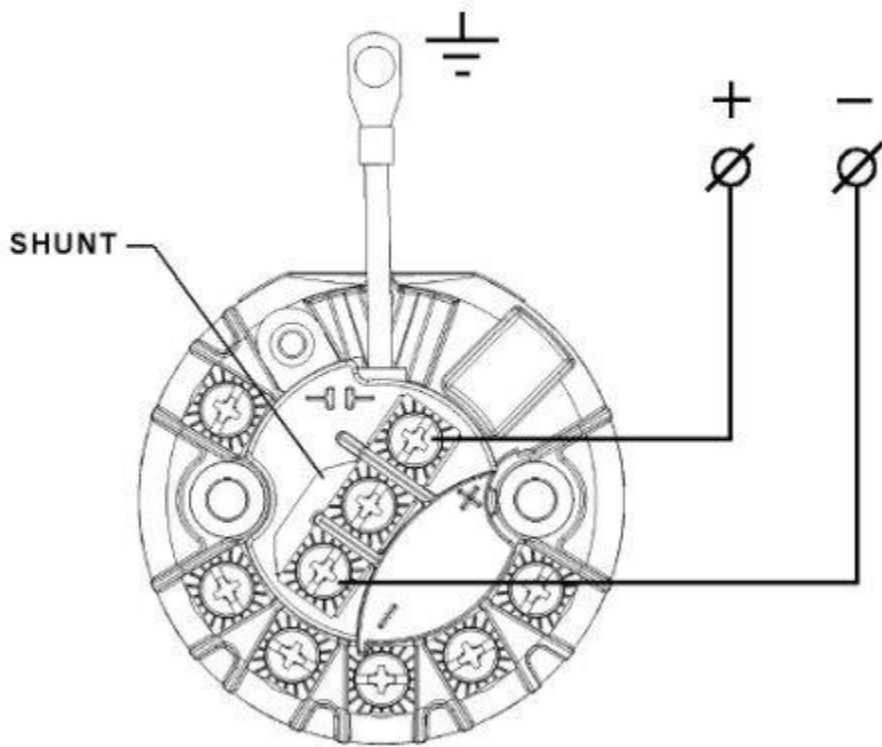

Figure 15 – Installation without EU Meter

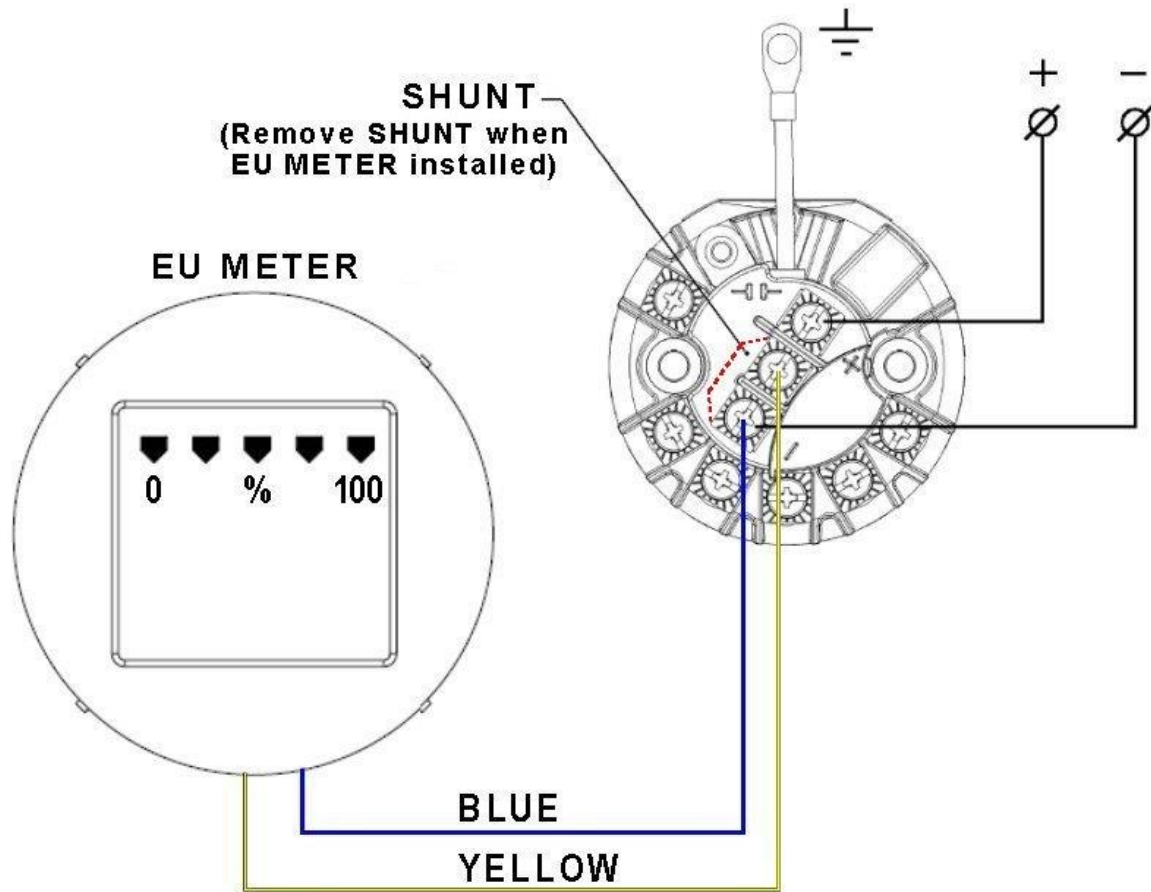

Figure 16 – Installation with EU Meter

3.4.6.2. Maintenance

The unit is designed to give a long service life under normal industrial conditions. However, if exposed to a large number of high energy transients beyond the capability of the unit, the lightning protector may fail. The unit has been designed so that, under excessive surge conditions (more than 10 KA), the lightning protector should fail, thus protecting the transmitter.

If the unit has failed, it can be replaced in the field – the process for removal in the reserve of that for installing the unit.

If a replacement is not immediately available, part number 50133588-501-501, it is possible to bypass the unit by wiring directly to the transmitter; however, it should be remembered that, in this case, the transmitter will be unprotected from surges.

4. Startup

4.1.1. Overview

This section identifies typical startup tasks the STT700 temperature transmitter and includes the procedure for running an optional analog output check.

4.1.2. Startup Tasks

After completing the installation and configuration tasks for a transmitter, you are ready to startup the process loop. Startup usually includes:

- Setting initial resistance, based on actual temperature (RTD sensor types only)
- Reading inputs and outputs
- Applying process inputs to the transmitter.

You can also run an optional output check to *wring out* an analog loop and check out individual Process Variable (PV) outputs in Digitally Enhanced (DE) mode before startup.

The actual steps in a startup procedure vary based on the type of transmitter and the measurement application. In general, the procedures in this section are based on using Honeywell MC Toolkit, with a HART or DE variant, to check the transmitter input and output under static process conditions, and make adjustments as required initiating full operation with the running process.

4.1.3. Output Check Procedures

The Output Check comprises the following procedures:

- The Loop Test procedure checks for continuity and the condition of components in the output current loop.
- The Trim DAC Current procedure calibrates the output of the Digital-to-Analog converter for minimum (0%) and maximum (100%) values of 4 mA and 20 mA, respectively. This procedure is used for transmitters operating online in analog mode to ensure proper operation with associated circuit components (for example, wiring, power supply, control equipment). Precision test equipment (an ammeter or a voltmeter in parallel with precision resistor) is required for the Trim DAC Current procedure.
- The Apply Values procedure uses actual Process Variable (PV) input levels for calibrating the range of a transmitter. The PV is carefully adjusted to stable minimum and maximum levels, and the Lower Range Limit Value (LRV) and Upper Range Limit Value (URV) are then set by commands from the MC Toolkit.



The transmitter does not measure the given PV input or update the PV output while it operates in the Output mode.

4.1.4. Constant Current Source Mode Procedure

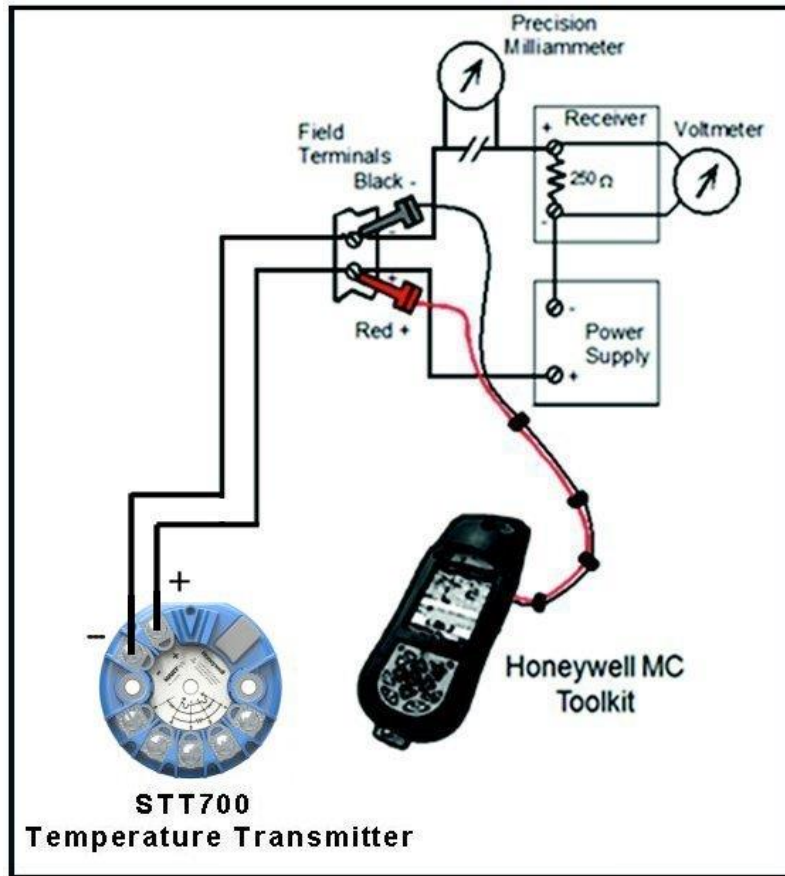

Figure 17 – Current Loop Test Connections

1. Refer to Figure 17 for test connections. Verify the integrity of electrical components in the output current loop.
2. Establish communication with the transmitter. For these procedures, the values of components in the current loop are not critical if they support reliable communication between the transmitter and the MC Toolkit.
3. On the MC Toolkit, display the **Output Calibration** box.
4. In the Output Calibration box, select the **Loop Test** button; the **LOOP TEST** box will be displayed.
5. Select the desired constant-level Output: 0 %, 100 %, or Other (any between 0 % - 100 %).
6. Select the Set button. A box will be displayed asking **Are you sure you want to place the transmitter in output mode?**



With the transmitter in Analog mode, you can observe the output on an externally-connected meter or on a local meter.

7. Select the **Yes** button. Observe the output current at the percentage you selected in Step 5.
8. To view the monitor display, navigate back from the **LOOP TEST** display, and select the **MONITOR** display. A **Confirm** popup will be displayed.
9. Select **Yes** to continue. This concludes the Startup procedure.

5. Operation

5.1. Overview

The Operations section describes the internal operation of the STT700 transmitter and the operations of the Smart Field Communicator and the HART communicator with the STT700. If an EU Meter is installed, see the Engineering Unit Meter User Guide 34-ST-25-18 for additional information on operations.

This transmitter is powered via the 2-wire, 4-20 mA signal connected to the + and - terminals on the output side of the module.

5.2. Configuration Tools

5.2.1. Smart Field Communicator (SFC) for DE Models

As previously indicated, the SFC communicates by connecting across the 4-20 mA wiring. DE communication is by 16 mA pulses which disturb the 4-20 mA output signal. When in analog mode, ensure that receiving instruments are not on automatic control. The SFC does not feed 16 mA pulses into the loop but instead merely uses the power on the 4-20 mA wires and switches it through a field effect transistor output switch. The SFC always acts as a master and the transmitter as a slave. When the transmitter is operating in the digital DE mode, there is no wake-up pulse required and the SFC communication does not disturb the PV signal. Consequently, there is no need to put the loop on manual control when operating in the DE mode.

Supported Commands:

- Read/write ID (e.g. TID 250)
- Select a sensor type (e.g. Pt100)
- Enable/disable sensor break detection
- Set damping time (e.g. 0 second)
- Set LRV and URV
- Read URL (upper range limit), LRL (lower range limit) and span
- Read process value and cold junction value in engineering units
- Read output in % of span
- Read software version
- Read fail-safe direction configured by link
- Set/reset user calibration to specific sensor
- Set 0 and 100% output calibration
- Force output current
- Read/write scratch pad
- Select broadcast type 4 or 6 bytes (Digital DE only). 6 bytes broadcasts PV and transmitter database while 4 bytes broadcasts PV only
- Enable/disable write protect
- Enable/disable latching. Latching means the alarm needs acknowledgment. Press "STATUS" key to acknowledge the alarm. If latching is disabled, the transmitter will leave the alarm mode as soon as the alarm cause disappears.

5.2.2. HART Communicator Model 375, 475 or MC Toolkit FDC for HART 7 Models

Connect the HART communicator by attaching the leads in parallel with the input (24V) terminals of the device. HART communication consists of a high frequency carrier superimposed onto the 4-20 mA signal. The HART transmitter transmits by modulating the 4-20 mA DC loop current with a 1 mA peak to peak (p-p) AC current signal.

Supported Commands

- Read/write ID
- Select Dual Mode TC/TC, RTD/RTD
- Select sensor type
- Select PV/SV units
- Select damping time
- Set LRV and URV
- Read URL and LRL
- Read analog output
- Read Sensor1 and Sensor2
- Read % Output
- Read Process Value (PV)
- Read Cold Junction (CJ) Value
- Read fail-safe direction
- Set 0% and 100% output calibration
- Force output current
- Enable/disable latching
- XS Delta detection ON/OFF
- Set Delta Alarm
- Read Delta
- Match PVs
- Read device status
- Set/clear write protect
- Select Loop Control Mode – Average, Difference, Sensor1, Sensor2, Redundant and Split-Range
- Lock/Unlock device
- Read/Write Long tag
- Read/write message, descriptor, date
- Read/Write polling address
- Read/Write loop current mode

Advanced Diagnostics

- Read Install Date
- Write Install Date
- Read Calibration Date and Time
- Write Correct LRV Date and Time
- Write Correct URV Date and Time
- Read Time in service value
- Read first set of Error log data
- Read second set of Error log data
- Read Error Log option status
- Write Error Log option status
- Reset Error Log
- Read PV tracking data
- Read SV tracking data
- Write high and low alarm limits for PV and SV
- Reset tracking data
- Read power up count
- Reset power up count value
- Read device model number
- Read Sensor1 and Sensor2 limits
- Read middle range value (MRV)
- Write middle range value (MRV)
- Read Loop Control option value
- Write Loop Control option value
- Read hysteresis
- Write hysteresis value
- Read damping value for bump less transfer (applicable to Split Range option)
- Write damping value for bump less transfer (applicable to Split Range option)

6. Maintenance

6.1. Overview

Maintenance of this transmitter is limited to ensuring that connections, seals and mounting hardware are tight and secure. There are no moving parts or adjustments, thus, the only reason to open the housing (where supplied) is to inspect for corrosion or conductive dust entry which could later affect reliable operation.

	<p>WARNING: The transmitter module itself should NEVER be opened.</p>
---	---

6.2. Preventive Maintenance Practices and Schedules

This SmartLine transmitter does not require any specific maintenance at regularly scheduled intervals.



Please take appropriate steps to avoid ESD damage when handling

6.3. Troubleshooting

6.3.1. Troubleshooting with SFC

Troubleshooting the STT700 DE transmitter loop is greatly simplified by connecting the SFC in the termination area near the receiving instrument. Also connect a digital volt meter (DVM), at the termination area for the receiving instrument, to confirm a similar signal is coming from the field and power is available on the two wires of the 4-20 mA loop. This isolates the problem to either field loop or receiving instrument/power supply/wiring/safety barriers etc. If the original symptom was an unstable input, it could be a loose connection on the receiving side. Assuming the above confirms a field loop problem, the likely causes and actions are given below.

For any step the first action is to hook up the SFC to the transmitter and press "ID", then "STATUS".

SYMPTOM	SFC MESSAGE/ DISPLAY	POSSIBLE CAUSE	CURE
No input or low input	" INPUT OPEN " (with downscale fail-safe) " I/P OUT OF SPEC " (indicates that the input is below LRL) " HI RES/LO VOLTS " which indicates an open circuit loop	Bad sensor wire connection. Incorrect operating voltage.	Check out field wiring and connections. Ensure that the transmitter is in its voltage operating area. Verify that the 250 ohms resistor is in loop.
High input	" INPUT OPEN " (with upscale fail-safe) " I/P OUT OF SPEC " (indicates that the input is above URL or below LRL)	Bad sensor wire connection.	Check field wiring and connections for partial short circuit. Check that the transmitter is in its voltage operating area and

SYMPTOM	SFC MESSAGE/ DISPLAY	POSSIBLE CAUSE	CURE
		Incorrect operating voltage.	line resistance is not excessive.
Unstable onscale input	"STATUS CHECK = O.K." since any identified problem would give upscale or downscale fail-safe.	Bad sensor wire connection. Intermittent open circuit of sensor. Wiring disturbed by strong electromagnetic interference.	Check connection and wiring for intermittent connections. Check that sensor fault detection is "ON", this allows detection of a bad sensor. Protect wiring by using appropriate grounding, shielding etc.
Fail-safe output signal	"CRITICAL STATUS"	A fail-safe output signal (critical status) can be caused by several reasons.	The SFC will indicate the source of the problem by displaying the appropriate error message.
Incorrect output signal with simulating device	"STATUS CHECK = O.K." but does not correspond to value set by simulating device	The most common error is changing the sensor wiring after probe type selection or after power-up.	Check the appropriate sensor wiring and power cycle when it is correct. Remember when changing configuration to first connect sensor wiring correctly, then change configuration.
"INVALID REQUEST" when changing LRV or URV	"INVALID REQUEST"	If the LRV is changed, the URV tries to change by the same amount to maintain the same SPAN. If this new URV exceeds the URL then this message appears.	Reduce the URV or SPAN before changing the LRV.
Non-critical status message, without # sign	"USER CORR ACTIVE"	Transmitter has been trimmed for particular sensor range. This can be done by keying in LRV/URV, CORRECT, ENTER with exact LRV and URV input values to enable improved accuracy over the specifications.	When performing a Reset Correct command or a sensor type change, the transmitter will lose this sensor correction and fall back to the original factory calibration.
<p>Remember that successful communications with the transmitter result in many useful pieces of data. With the initial I.D. response, the user can confirm that the:</p> <ol style="list-style-type: none"> 1. Transmitter is powered 2. Line resistance is correct <p>Wires run to the correct unit. If not, the unit connected can be identified by the tag number.</p>			

6.3.2. Troubleshooting with HART communicator

Troubleshooting the STT700 HART transmitter loop is greatly simplified by connecting a HART Communicator in the termination area near the receiving instrument. Also connect a digital volt meter (DVM), at the termination area for the receiving instrument, to confirm a similar signal is coming from the field and power is available on the two wires of the 4-20 mA loop. This isolates the problem to either field loop or receiving instrument/power supply/wiring/safety barriers etc. If the original symptom was an unstable input, it could be a loose connection on the receiving side. Assuming the above confirms a field loop problem, the likely causes/actions are given below.

Condition	Analysis	Recommended Corrective Action
<p>Diagnostics Failure. A critical failure has been detected on the HART Electronics.</p>	<p>Use a HART device communicator to read the detailed status information from the transmitter. Refer to the appropriate manual for more details about the possible failure causes.</p>	<p>Power cycle the transmitter and if problem persists replace the transmitter.</p>
<p>DAC Failure. A critical failure has been detected on the HART Electronics.</p>	<p>Use a HART device communicator to read the detailed status information from the transmitter. Refer to the appropriate manual for more details about the possible failure causes.</p>	<p>Power cycle the transmitter and if problem persists replace the transmitter.</p>
<p>Sensor Input Failure. A critical failure has been detected on the HART Sensor Inputs.</p>	<p>Use a HART device communicator to read the detailed status information from the transmitter. Refer to the appropriate manual for more details about the possible failure causes.</p>	<p>If detail status indicate input fault (open, short...), correct the root error by checking the input connection to the transmitter and sensor type configuration.</p> <p>If problem persists even after verifying the input connection and sensor input type configuration, replace the transmitter.</p>
<p>Configuration Corrupt. A critical failure has been detected on the HART Electronics.</p>	<p>Use a HART device communicator to read the detailed status information from the transmitter. Refer to the appropriate manual for more details about the possible failure causes.</p>	<p>Power cycle the transmitter and if problem persists replace the transmitter.</p>

For DE please refer to STT700 HART/DE option manual, #34-TT-25-18.

6.4. Recommended Parts

GENERAL DESCRIPTION:	Reference
STT700 transmitter module device	Order from the Model Selection Guide to include options as required.
METERS	
Replacement EU meter	51451985-501
Meter mounting bracket kit	46188056-502
HEAD MOUNT HOUSINGS (Cable/Conduit entry noted. All have 1/2" NPT sensor entry)	
Aluminum head mount housing (M20)	46188452-501
Aluminum head mount housing (1/2"NPT)	46188452-502
Flame proof cast iron head mount housing (M20)	46188453-501
Flame proof cast iron head mount housing (1/2"NPT)	46188453-502
FIELD MOUNT HOUSINGS (All have 1/2" NPT sensor and cable/conduit entries)	
Field mount housing - Aluminum beige epoxy-polyester hybrid painted	46188472-501
Field mount housing end cap - Aluminum beige epoxy	30752006-501
Field mount housing meter cap - Aluminum beige epoxy-polyester hybrid painted	30755956-501
Field mount housing - Aluminum beige epoxy painted	46188472-502
Field mount housing end cap - Aluminum beige epoxy painted	46188471-501
Field mount housing meter cap - Aluminum beige epoxy painted	46188471-502

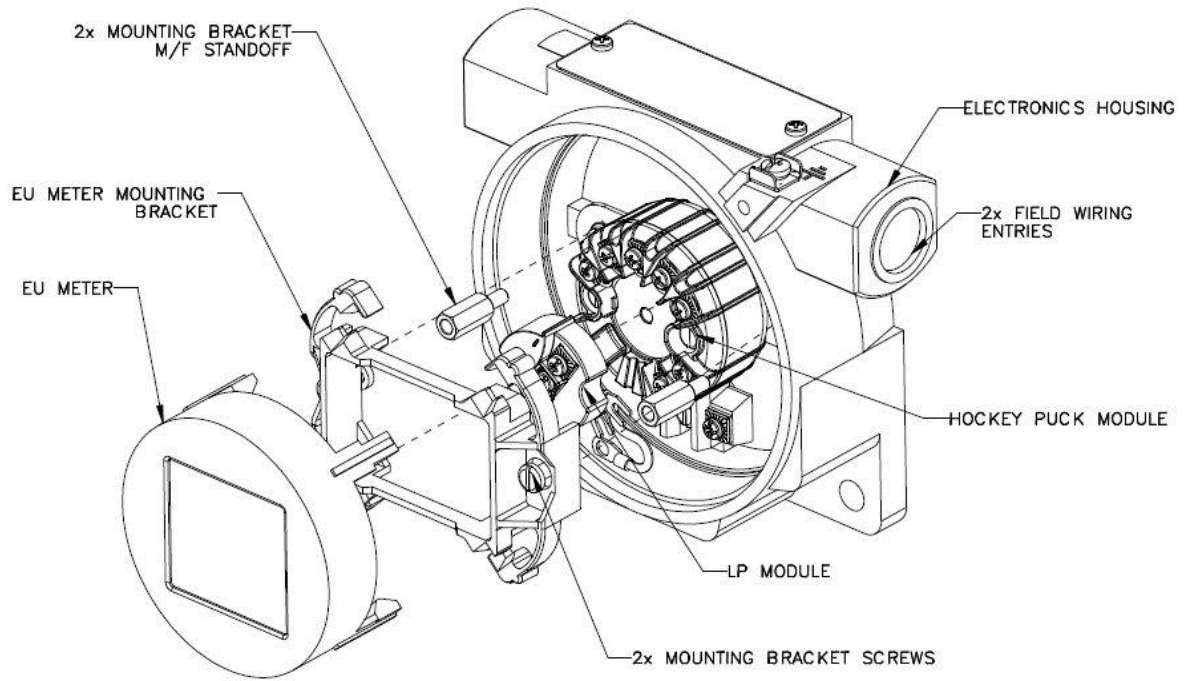

HOUSING WITH EU METER

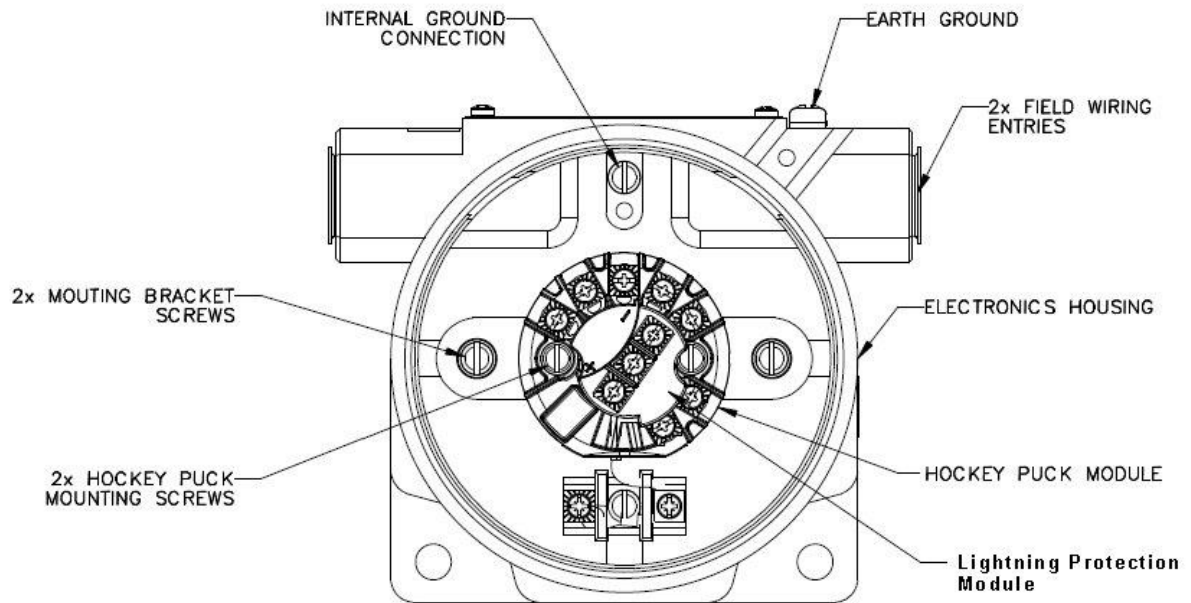

HOUSING WITHOUT EU METER

MISCELLANEOUS PARTS (TBC)	
Adaptor plate to install module in field mount housing	46188423-501
Spring loading mounting set	46188416-501
DIN rail mounting (top hat/"Ω" or "G" rail)	51156364-501
Carbon steel mounting bracket for 2" pipe (for use with field mount housing)	30755905-501
Stainless steel mounting bracket for 2" pipe (for use with field mount Housing)	30671907-501
1/2"NPT to M20 x 1.5 conduit adaptor (flameproof EEx d)	46188203-501 46188203-501
1/2"NPT Male to 3/4"NPT Female conduit adaptor	51196567-501 51196567-501
Transient protector (external to housing)	30755970-501
Stainless steel wired-on customer ID tag	500080380501
Lightning Protector	50133588-501

6.5. Wiring and Installation Drawings

Spring loading and sensor assembly	51307912-001
Pipe mounting dimensions for field mounting housing	46188468-201
Wall mounting dimensions for field mounting housing	46188467-201
DIN rail mounting for the STT700 transmitter module	51156364-501

7. Calibration

7.1. Recommendations for transmitter Calibration

The STT700 SmartLine Temperature Transmitter does not require periodic calibration to maintain accuracy. Typically, calibration of a process-connected transmitter will degrade, rather than augment the capability of a smart transmitter. For this reason, it is recommended that a transmitter be removed from service before calibration. Moreover, calibration must be accomplished in a controlled, laboratory-type environment, using certified precision equipment.

7.2. Calibration Procedures

For a transmitter operating in analog mode, you must calibrate its output signal measurement range using any compatible hand-held communicator..

One calibration option is to use the Honeywell MC Toolkit (MCT). Refer to the *MC Toolkit User Manual*, MCT404, Document # 34-ST-25-50

Calibration information and procedures for a transmitter operating in the HART/DE mode are provided in the *STT700 Series HART/DE Option User's manual*, document number 34-TT-25-18, Section on "Calibration."

Appendix A. PRODUCT CERTIFICATIONS

A1. Safety Instrumented Systems (SIS) Installations

For Safety Certified Installations, please refer to STT700 Safety Manual 34-TT-25-05 for installation procedure and system requirements.

A2. European Directive Information (EU)

	
APPV-STT700-CE Revision: A	
EU DECLARATION OF CONFORMITY	
<p>We, Honeywell International Inc. Honeywell Field Solutions 512 Virginia Drive Fort Washington, PA 19034 USA</p>	
<p>declare under our sole responsibility that the following products, STT 700 – Smart Series Temperature Transmitter</p>	
<p>to which this declaration relates, is in conformity with the provisions of the European Community Directives, including the latest amendments, as shown in the attached schedule.</p>	
<p>Assumption of conformity is based on the application of the harmonized standards and when applicable or required, a European Community notified body certification, as shown in the attached schedule.</p>	
<p>The authorized signatory to this declaration, on behalf of the manufacturer, and the Responsible Person is identified below.</p>	
	
<p>Owen J. Murphy Product Safety & Approvals Engineering Issue Date: 15 June 2017 Fort Washington, PA 19034, USA</p>	

SCHEDULE

APPV-STT700-CE Revision: A

EMC Directive (2014/30/EU)

EN 61326-1:2013 Electrical Equipment for Measurement, Control and Laboratory Use – EMC Requirements.

Overview of EMC Testing

Summary of Tests Performed:

PORT	TEST	STANDARD	CRITERIA (IEC 61326-1)	CRITERIA (IEC 61326-3-1)	RESULTS
Enclosure	Radiated Emission	CISPR 11	Group1, Class A 30 – 230 MHz: 40 dB 230 – 1000 MHz: 47 dB	Group1, Class A 30 – 230 MHz: 40 dB 230 – 1000 MHz: 47 dB	PASS
	ESD Immunity	IEC61000-4-2	+/- 4KV Contact +/- 8KV Air	+/- 6KV Contact +/- 8KV Air	PASS
	EM Field- RF Radiated Susceptibility	IEC61000-4-3	10 V/m- 80 MHz to 1GHz	20 V/m- 80MHz to 1GHz	PASS
			3 V/m - 1.4 GHz to 2.0 GHz	10 V/m - 1.4GHz to 2.0 GHz	PASS
1 V/m- 2.0 GHz to 2.7 GHz			3 V/m- 2.0GHz to 2.7GHz	PASS	
50Hz/60Hz Magnetic Field Immunity	IEC 6100-4-8	30 A/m	30 A/m	N/A 1	
DC Power	EFT(B) Immunity	IEC61000-4-4	+/- 1KV	+/- 2KV	PASS
	Surge Immunity	IEC61000-4-5	+/- 1KV	+/- 2KV	PASS
	RF Conducted Susceptibility	IEC61000-4-6	3V	3 V Except the following: 10 V 3.39 to 3.410MHz 10 V 6.765 to 6.795MHz 10 V 13.553 to 13.567MHz 10 V 26.957 to 27.283MHz 10 V 40.66 to 40.70MHz	PASS
I/O Signal/ Control (Including Earth Lines)	EFT(Burst) Immunity	IEC61000-4-4	+/- 1KV	+/- 2KV	2
	Surge Immunity	IEC61000-4-5	+/- 1KV	+/- 2KV	2
	RF Conducted Susceptibility	IEC61000-4-6	3V	3 V Except the following: 10 V 3.39 to 3.410MHz 10 V 6.765 to 6.795MHz	2

SCHEDULE

APPV-STT700-CE Revision: A

PORT	TEST	STANDARD	CRITERIA (IEC 61326-1)	CRITERIA (IEC 61326-3-1)	RESULTS
				10 V 13.553 to 13.567MHz 10 V 26.957 to 27.283MHz 10 V 40.66 to 40.70MHz	
AC Power	Voltage Dip	IEC61000-4-11	0% during 1 Cycle 40% during 10-12 Cycles 70% during 25-30 Cycles		N/A ³
	Short Interruptions	IEC61000-4-11	0% during 250-300 Cycles		N/A ³
	EFT(Burst) Immunity	IEC61000-4-4	2KV		N/A ³
	Surge Immunity	IEC61000-4-5	1KV/ 2KV		N/A ³
	RF Conducted Susceptibility	IEC61000-4-6	3V		N/A ³

1. There is no magnetic sensitive circuitry.
2. Done as part of the DC Power Testing.
3. Product is DC Powered.

SCHEDULE

APPV-STT700-CE Revision: A

ATEX Directive (2014/34/EU)

EC-Type Examination Certificate No: SIRA 17ATEX2162X Protection: Flameproof, Dust and Intrinsically Safe

Equipment Group II Category 1 G and Group II Category 1 G

Without EU Meter : Ex ia IIC T6..T4 Ga

T6: -40 °C to +40 °C

T5: -40 °C to +55 °C

T4: -40 °C to +70 °C

With EU Meter : Ex ia IIC T4 Ga

T4: -40 °C to +70 °C

Equipment Group II Category 2 G and Group II Category 2 D

Ex db IIC T4 Gb (Ta= -50°C TO 85°C)

Ex tb IIIC T95°C Db (Ta= -50°C TO 85°C)

T6: -40 °C to +65 °C

T95°C/T5: -40 °C to +85 °C

Harmonized Standards :

EN 60079-0: 2012+A11 : 2013; EN 60079-1 : 2014; EN 60079-11: 2012;

EN 60079-31 : 2014

Type Examination Certificate No: SIRA 14ATEX4052X - Protection: Increased Safety and Zone 2 Intrinsic Safety Certificate

Equipment Group II Category 3 G

Without EU Meter : Ex ec IIC T6..T4 Gc

Ex ic IIC T6..T4 Gc

T6: -40 °C to +40 °C

T5: -40 °C to +55 °C

T4: -40 °C to +85 °C

With EU Meter : Ex ec IIC T4 Gc

Ex ic IIC T4 Gc

T4: -40 °C to +85 °C

Harmonized Standards :

EN 60079-0: 2012+A11 : 2013; EN 60079-11: 2012; EN 60079-7 : 2015;

ATEX Notified Body for EC Type Certificates

Sira Certification Service [Notified Body Number: 0518]

Unit 6, Hawarden Industrial Park,

Hawarden, Deeside, CH5 3US,

United Kingdom

SCHEDULE

APPV-STT700-CE Revision: A

ATEX Notified Body for Quality Assurance
DEKRA Certification B.V. [Notified Body Number: 0344]
Maender 1051
6825 MJ Arnhem
The Netherlands

A3. China RoHS

China RoHS compliance information is located here: (Pending)



<https://www.honeywellprocess.com/library/support/Public/Documents/50136434.pdf>

A4. Hazardous Locations Certifications

MSG CODE	AGENCY	TYPE OF PROTECTION	Electrical Parameters	Ambient Temperature
F1	FM Approvals™ (USA)	Intrinsically Safe Certificate: 17US0112X Class I Division 1, Groups A, B, C, D; T6.. T4 Class I Zone 0 AEx ia IIC T6.. T4 Ga	Note 2	T6: -40 °C to +40 °C T5: -40 °C to +55 °C T4: -40 °C to +70 °C
		Non-Incendive and Zone 2 Intrinsically Safe Certificate: 17US0112X Class I, Division 2, Groups A, B, C, D; T6.. T4 Class I Zone 2 AEx nA IIC T6.. T4 Gc Class I Zone 2 AEx ic IIC T6.. T4 Gc	Note 1	T6: -40 °C to +40 °C T5: -40 °C to +55 °C T4: -40 °C to +85 °C
F2 (No EU Meter)	FM Approvals™ (USA)	Explosion proof Certificate: 17US0112X Class I, Division 1, Groups A, B, C, D; T6.. T5 Dust Ignition Proof: Class II, III, Division 1, Groups E, F, G; T6.. T5 Class 1, Zone 1, AEx db IIC T6.. T5 Gb Zone 21, AEx tb IIIC T 95°C Db	Note 1	T6: -40 °C to +65 °C T95°C/T5: -40 °C to +85 °C
		Intrinsically Safe Certificate: 17US0112X Class I, II, III, Division 1, Groups A, B, C, D, E, F, G; T6.. T4 Class I Zone 0 AEx ia IIC T6.. T4 Ga Class I Zone 2 AEx ic IIC T6.. T4 Gc	Note 2	T6: -40 °C to +40 °C T5: -40 °C to +55 °C T4: -40 °C to +70 °C
		Non-Incendive and Zone 2 Intrinsically Safe Certificate: 17US0112X Class I, Division 2, Groups A, B, C, D; T6.. T4 Class I Zone 2 AEx ic IIC T6.. T4 Gc	Note 1	T6: -40 °C to +40 °C T5: -40 °C to +55 °C T4: -40 °C to +85 °C
		Enclosure: Type 4X/ IP66/ IP67		
F2 (W/ EU Meter)	FM Approvals™ (USA)	Explosion proof Certificate: 17US0112X Class I, Division 1, Groups A, B, C, D; T6.. T5 Dust Ignition Proof: Class II, III, Division 1, Groups E, F, G; T6.. T5 Class I, Zone 1, AEx db IIC T6.. T5 Gb Zone 21, AEx tb IIIC T 95°C Db	Note 1	T6: -40 °C to +65 °C T95°C/T5: -40 °C to +85 °C
		Intrinsically Safe Certificate: 17US0112X Class I, II, III, Division 1, Groups A, B, C, D, E, F, G; T4 Class I Zone 0 AEx ia IIC T4 Ga	Note 2	T4: -40 °C to +70 °C
		Non-Incendive and Zone 2 Intrinsically Safe Certificate: 17US0112X Class I, Division 2, Groups A, B, C, D; T4 Class I Zone 2 AEx ic IIC T4 Gc	Note 1	T4: -40 °C to +85 °C
		Enclosure: Type 4X/ IP66/ IP67		

	FM Approvals™ (USA)	Standards: FM 3600:2011; ANSI/ UL 60079-0: 2013 FM 3616 : 2011; FM 3615 : 2011; ANSI/ UL 60079-1: 2015 ; ANSI/ UL 60079-31: 2015; FM 3610:2015; ANSI/ UL 60079-11 : 2013 FM 3810 : 2005 ; FM 3611:2016; ANSI/ UL 913: Edition 7; ANSI/ UL 916 : Edition 4 ;		
C1	CSA-Canada and USA	Intrinsically Safe Certificate: 70113941 Class I Division 1, Groups A, B, C, D; T6.. T4 Class I Zone 0 AEx ia IIC T6.. T4 Ga Ex ia IIC T6.. T4 Ga	Note 2	T6: -40 °C to +40 °C T5: -40 °C to +55 °C T4: -40 °C to +70 °C
		Non-Incendive and Zone 2 Intrinsically Safe Certificate: 70113941 Class I, Division 2, Groups A, B, C, D; T4 Class I Zone 2 AEx nA IIC T6.. T4 Gc Ex nA IIC T6.. T4 Gc Class I Zone 2 AEx ic IIC T6.. T4 Gc Ex ic IIC T6.. T4 Gc	Note 1	T6: -40 °C to +40 °C T5: -40 °C to +55 °C T4: -40 °C to +85 °C
		Enclosure: Type 1/ IP20		
C2 (No EU Meter)	CSA-Canada and USA	Explosion proof Certificate: 70113941 Class I, Division 1, Groups A, B, C, D; T6.. T5 Ex db IIC T6.. T5 Gb Class 1, Zone 1, AEx db IIC T6.. T5 Gb Dust-Ignition Proof: Class II, III, Division 1, Groups E, F, G; T6.. T5 Ex tb IIIC T 95°C Db Zone 21 AEx tb IIIC T 95°C Db	Note 1	T6: -40 °C to +65 °C T95°C/T5: -40 °C to +85 °C
		Intrinsically Safe Certificate: 70113941 Class I, II, III, Division 1, Groups A, B, C, D, E, F, G; T6.. T4 Class I Zone 0 AEx ia IIC T6.. T4 Ga Ex ia IIC T6.. T4 Ga	Note 2	T6: -40 °C to +40 °C T5: -40 °C to +55 °C T4: -40 °C to +70 °C
		Non-Incendive and Zone 2 Intrinsically Safe Certificate: 70113941 Class I, Division 2, Groups A, B, C, D; T6..T4 Class I Zone 2 AEx ic IIC T6..T4 Gc Ex ic IIC T6.. T4 Gc	Note 2	T6: -40 °C to +40 °C T5: -40 °C to +55 °C T4: -40 °C to +85 °C
		Enclosure: Type 4X/ IP66/ IP67		
C2 (W/ EU Meter)	CSA-Canada	Explosion proof Certificate: 70113941 Class I, Division 1, Groups A, B, C, D; T6.. T5 Ex db IIC T6..T5 Gb Class 1, Zone 1, AEx db IIC T6.. T5 Gb Dust Ignition Proof: Class II, III, Division 1, Groups E, F, G; T6.. T5 Ex tb IIIC T 95°C Db Zone 21 AEx tb IIIC T 95°C Db	Note 1	T6: -40 °C to +65 °C T95°C/T5: -40 °C to +85 °C

C2 (W/ EU Meter)	CSA-Canada	Intrinsically Safe Certificate: 70113941 Class I, II, III, Division 1, Groups A, B, C, D, E, F, G; T4 Class I Zone 0 AEx ia IIC T4 Ga Ex ia IIC T4 Ga	Note 1	T4: -40 °C to +70 °C
		Non-Incendive and Zone 2 Intrinsically Safe Certificate: 70113941 Class I, Division 2, Groups A, B, C, D; T4 Class I Zone 2 AEx ic IIC T4 Gc Ex ic IIC T4 Gc	Note 2	T4: -40 °C to +85 °C
		Enclosure: Type 4X/ IP66/ IP67		
		Standards: CSA C22.2 No. 0-10: 2006; CSA 22.2 No. 25-1966 (reaffirmed 2009); CSA C22.2 No. 30-M1986 (reaffirmed 2012); CSA C22.2 No. 94-M91; CSA C22.2 No. 61010-1: 2013; CSA-C22.2No.157-92 (reaffirmed 2012); C22.2 No. 213: 2016; C22.2 No. 60529-05 C22.2 No. CSA 60079-0:2011; C22.2 No. 60079-1: 2011; C22.2 No. 60079-11: 2011; C22.2 No. 60079-31: 2012;		
A1	ATEX	Intrinsically Safe Certificate: SIRA 17ATE2162X Ex II 1 G Ex ia IIC T6..T4 Ga	Note 2	T6: -40 °C to +40 °C T5: -40 °C to +55 °C T4: -40 °C to +70 °C
		Non Sparking and Zone 2 Intrinsically Safe Certificate: SIRA 17ATE4161X Ex II 3 G Ex ec IIC T6.. T4 Gc Ex II 3 G Ex ic IIC T6.. T4 Gc	Note 1	T6: -40 °C to +40 °C T5: -40 °C to +55 °C T4: -40 °C to +70 °C
		Enclosure: IP20		
A2 (No EU Meter)	ATEX	Flameproof Certificate: SIRA 17ATE2162X Ex II 2 G Ex db IIC T6.. T5 Gb II 2 D Ex tb IIIC T 95°C Db	Note 1	T6: -40 °C to +65 °C T95°C/T5: -40 °C to +85 °C
		Intrinsically Safe Certificate: SIRA 17ATE2162X Ex II 1 G Ex ia IIC T6.. T4 Ga	Note 2	T6: -40 °C to +40 °C T5: -40 °C to +55 °C T4: -40 °C to +70 °C
		Non Sparking Certificate : HON 17.0202X Ex II 3 G Ex ec IIC T4 Gc Category 3 Intrinsically Safe Certificate : SIRA 17ATE4161X Ex II 3 G Ex ic IIC T4 Gc	Note 1 Note 2 for "ic"	T6: -40 °C to +40 °C T5: -40 °C to +55 °C T4: -40 °C to +85 °C
		Enclosure: IP66/ IP67		
A2 (W/ EU Meter)	ATEX	Flameproof Certificate: SIRA 17ATE2162X Ex II 2 G Ex db IIC T6.. T5 Gb II 2 D Ex tb IIIC T 95°C Db	Note 1	T6: -40 °C to +65 °C T95°C/T5: -40 °C to +85 °C
		Intrinsically Safe Certificate: SIRA 17ATE2162X Ex II 1 G Ex ia IIC T4 Ga	Note 2	T4: -40 °C to +70 °C

A2 (W/ EU Meter)	ATEX	Non Sparking Certificate : HON 17.0202X  II 3 G Ex ec IIC T4 Gc Category 3 Intrinsically Safe Certificate : SIRA 17ATE4161X  II 3 G Ex ic IIC T4 Gc	Note 1 Note 2 for "ic"	T4: -40 °C to +85 °C
		Enclosure: IP66/ IP67		
		Standards: EN 60079-0: 2012+A11 : 2013; EN 60079-1 : 2014 ; EN 60079-11: 2012 ; EN 60079-7 : 2015 ; EN 60079-31 : 2014 ;		
E1	IECEx	Intrinsically Safe Certificate: SIR 17.0035X Ex ia IIC T6.. T4 Ga	Note 2	T6: -40 °C to +40 °C T5: -40 °C to +55 °C T4: -40 °C to +70 °C
		Non Sparking and Zone 2 Intrinsically Safe Certificate: SIR 17.0035X Ex ec IIC T6.. T4 Gc Ex ic IIC T6.. T4 Gc	Note 1	T6: -40 °C to +40 °C T5: -40 °C to +55 °C T4: -40 °C to +85 °C
		Enclosure: IP20		
E2 (No EU Meter)	IECEx	Flameproof Certificate: SIR 17.0035X Ex db IIC T6.. T5 Gb Ex tb IIIC T 95°C Db	Note 1	T6: -40 °C to +65 °C T95°C/T5: -40 °C to +85 °C
		Intrinsically Safe Certificate: SIR 17.0035X Ex ia IIC T6.. T4 Ga	Note 2	T6: -40 °C to +40 °C T5: -40 °C to +55 °C T4: -40 °C to +70 °C
		Certificate: SIR 17.0035X Ex ic IIC T6.. T4 Gc	Note 2	T6: -40 °C to +40 °C T5: -40 °C to +55 °C T4: -40 °C to +85 °C
		Enclosure: IP66/ IP67		
E2 (W/ EU Meter)	IECEx	Flameproof Certificate: SIR 17.0035X Ex db IIC T6.. T5 Gb Ex tb IIIC T 95°C Db	Note 1	T6: -40 °C to +65 °C T95°C/T5: -40 °C to +85 °C
		Intrinsically Safe Certificate: SIR 17.0035X Ex ia IIC T4 Ga	Note 2	T4: -40 °C to +70 °C
		Zone 2 Intrinsically Safe Certificate: SIR 17.0035X Ex ic IIC T4 Gc	Note 1 & 2	T4: -40 °C to +85 °C
		Enclosure: IP66/ IP67		
		Standards: IEC 60079-0: 2011; IEC 60079-1 : 2014; IEC 60079-11 : 2011; IEC 60079-31 : 2014		

Notes

1. Operating Parameters:

4-20 mA/HART (Loop Terminal) - Voltage= 10.58 to 35 V, Current = 4-20 mA Normal (3.8 – 21.5 mA Faults)

2. Intrinsically Safe Entity Parameters

For details see Control Drawing in in section A.7 of this manual

A5. Marking ATEX Directive

General:

The following information is provided as part of the labeling of the transmitter:

- Name and Address of the manufacturer
- Notified Body identification: DEKRA Quality B.V., Arnhem, the Netherlands

- For complete model number, see the Model Selection Guide for the particular model of temperature transmitter.
- The serial number of the transmitter is located on the Housing data-plate. The first two digits of the serial number identify the year (02) and the second two digits identify the week of the year (23); for example, 0223xxxxxxx indicates that the product was manufactured in 2002, in the 23rd week.

Apparatus Marked with Multiple Types of Protection

The user must determine the type of protection required for installation the equipment. The user shall then check the box [☐] adjacent to the type of protection used on the equipment certification nameplate. Once a type of protection has been checked on the nameplate, the equipment shall not then be reinstalled using any of the other certification types.

A.6 WARNINGS and Cautions:

Intrinsically Safe and Non-Incendive Equipment:

WARNING: SUBSTITUTION OF COMPONENTS MAY IMPAIR SUITABILITY FOR USE IN HAZARDOUS LOCATIONS.

Explosion-Proof/ Flameproof:

WARNING: DO NOT OPEN WHEN AN EXPLOSIVE ATMOSPHERE MAY BE PRESENT

Non-Incendive Equipment:

WARNING: DO NOT OPEN WHEN AN EXPLOSIVE ATMOSPHERE MAYBE PRESENT

All Protective Measures:

WARNING: FOR CONNECTION IN AMBIENTS ABOVE 60°C USE WIRE RATED 105°C

A.6 Conditions of Use” for Ex Equipment”, Hazardous Location Equipment or “Schedule of Limitations”:

The installer shall provide transient over-voltage protection external to the equipment such that the voltage at the supply terminal of the equipment does not exceed 140% of the voltage rating of the equipment.

Intrinsically Safe: Must be installed per drawing 50133855

Division 2: This equipment is suitable for use in a Class I, Division 2, Groups A, B, C, D; T4 or Non-Hazardous Locations Only.

Transmitter only selection:

For ATEX Category 3 or Zone 2 Locations, the Transmitter must be installed within an enclosure with a minimum degree of protection of IP54 in accordance with:

For US Installations: in a tool-secured enclosure which meets the requirements of ANSI/ISA 60079-0 and ANSI/ISA 60079-15 and the ultimate application.

For ATEX or IECEx: in a tool-secured enclosure which meets the requirements of EN/ IEC 60079-0 and EN/ IEC 60079-7 and the ultimate application.

Transmitter in Enclosure Selections:

Consult the manufacturer for dimensional information on the flameproof joints for repair.

Painted surface of the STT700 may store electrostatic charge and become a source of ignition in applications with a low relative humidity less than approximately 30% relative humidity where the painted surface is relatively free of surface contamination such as dirt, dust or oil. Cleaning of the painted surface should only be done with a damp cloth.

The enclosure is manufactured from low copper aluminum alloy. In rare cases, ignition sources due to impact and friction sparks could occur. This shall be considered during Installation, particularly if equipment is installed a Zone 0 location.

If a charge-generating mechanism is present, the exposed metallic part on the enclosure is capable of storing a level of electrostatic that could become Incendive for IIC gases. Therefore, the user/ installer shall implement precautions to prevent the buildup of electrostatic charge, e.g. earthing the metallic part. This is particularly important if equipment is installed a Zone 0 location.

For Installation of the NPT Plug or Adapter follow instructions as outlined in 34-XY-33-03.

A.6 Control Drawing

COPYRIGHT 2017, HONEYWELL INTERNATIONAL INC. NEITHER THIS DOCUMENT NOR THE INFORMATION CONTAINED HEREIN SHALL BE REPRODUCED, USED OR DISCLOSED TO OTHERS WITHOUT THE WRITTEN AUTHORIZATION OF HONEYWELL. USE, DUPLICATION, OR DISCLOSURE OF THIS DOCUMENT IS SUBJECT TO THE RESTRICTIONS SET FORTH IN A WRITTEN AGREEMENT. NOTHING CONTAINED HEREIN SHALL BE CONSTRUED AS CONFERRING BY IMPLICATION, ESTOPPEL, OR OTHERWISE ANY LICENSE TO ANY PATENT, TRADEMARK, COPYRIGHT OR OTHER INTELLECTUAL PROPERTY RIGHT OF HONEYWELL OR ANY THIRD PARTY.				PRE REL					
ISS	REVISION & DATE				APPD				
A	9 May 2017 ECN 2017- 1972				OJM				

STT700 Temperature Transmitter, ANALOG, and HART/DE Communications

1. Intrinsically safe installation shall be in accordance with
 - a. FM (USA): ANSI/NFPA 70, NEC[®] Articles 504 and 505.
 - b. CSA (Canada): Canadian Electrical Code (CEC), part I, section 18.
 - c. ATEX: Requirements of EN 60079-14, 12.3 (See also 5.2.4).
 - d. IECEX: Requirements of IEC 60079-14, 12.3 (See also 5.2.4).
2. ENTITY approved equipment shall be installed in accordance with the manufacturer's Intrinsic Safety Control Drawing.
3. The Intrinsic Safety ENTITY concept allows the interconnection of two ENTITY Approved Intrinsically safe devices with ENTITY parameters not specifically examined in combination as a system when:

$U_o, V_o, \text{ or } V_t \leq U_i \text{ or } V_{max}; I_o, I_{sc}, \text{ or } I_t \leq I_i \text{ or } I_{max}; C_a \text{ or } C_o \geq C_i + C_{cable}, L_a \text{ or } L_o \geq L_i + L_{cable}, P_o \leq P_i.$

Where two separate barrier channels are required, one dual-channel or two single-channel barriers may be used, where in either case, both channels have been Certified for use together with combined entity parameters that meet the above equations.
4. System Entity Parameters:

STT700 Transmitter: $V_{max} V_o \text{ or } U_o, I_{max} I_{sc} \text{ or } I_o;$

STT700 Transmitter: $C_i + C_{cable} \leq \text{Control Apparatus } C_a,$

SMV 800 Transmitter: $L_i + L_{cable} \leq \text{Control Apparatus } L_a.$
5. When the electrical parameters of the cable are unknown, the following values may be used:

Capacitance: 197pF/m (60 pF/ft)

Inductance: 0.66µH/m (0.020µH/ft).
6. Control equipment that is connected to Associated Equipment must not use or generate more than 250 V.
7. Associated equipment must be FM, CSA ATEX or IECEX (depending on location) listed. Associated equipment may be installed in a Class I, Division 2 or Zone 2 Hazardous (Classified) location if so approved.
8. Non-Galvanically isolated equipment (grounded Zener Barriers) must be connected to a suitable ground electrode per:
 - a. FM (USA): NFPA 70, Article 504 and 505. The resistance of the ground path must be less than 1.0 ohm.
 - b. CSA (Canada): Canadian Electrical Code (CEC), part I, section 10.
 - c. ATEX: Requirements of EN 60079-14, 12.2.4.
 - d. IECEX: Requirements of IEC 60079-14, 12.2.4.
9. Intrinsically Safe DIVISION 1/ Zone 0 WARNING: SUBSTITUTION OF COMPONENTS MAY IMPAIR SUITABILITY FOR USE IN HAZARDOUS LOCATIONS.
10. Division 2/ Zone 2: WARNING: DO NOT OPEN WHEN AN EXPLOSIVE GAS ATMOSPHERE IS PRESENT.
11. NO REVISION OF THIS CONTROL DRAWING IS PERMITTED WITHOUT AUTHORIZATION FROM THE AGENCIES listed.
12. For release approvals see ECN 2017-1972.

MASTER FILE TYPE: MS WORD	DRAWN			Honeywell		
	CHECKED			CONTROL DRAWING STT700 SERIES TEMP TRANSMITTER DIVISIONS 1 & 2 / ZONE 0 & 2		
	DEV ENG					
	MFG ENG					
	QA ENG					
	TOLERANCE UNLESS NOTED			A/A4	50133855	
ANGULAR DIMENSION			SCALE: None	USED ON	SH. 1 OF 4	

STT700 HART/DE No LP or EU Meter

Terminal	ENTITY PARAMETERS (Divisions and Zones Ex ia and Ex ic)	Associated Apparatus
1,2 (Loop)	U_i or $V_{max} = 30V$	U_o, V_{oc} or $V_t \leq 30V$
	i_i or $I_{max} = 225\text{ mA}$	I_o (I_{sc} or I_t) $\leq 225\text{ mA}$
	P_i or $P_{max} = 0.9W$	$P_o \leq 0.9\text{ W}$
	$C_i = 16\text{ nF}$	C_a or $C_o \geq C_{cable} + C_{STT700}$
	$L_i = 0\text{ }\mu\text{H}$	L_a or $L_o \geq L_{cable} + L_{STT700}$
5, 6, 7, 8 (SENSOR)	$C_o = 36\text{ }\mu\text{F}$	----
	$L_o = 657\text{ }\mu\text{H}$	----

NON-HAZARDOUS LOCATION

HAZARDOUS (CLASSIFIED) LOCATION

CLASS I, CLASS II, and CLASS III DIVISION 1, GROUPS A, B, C, D, E, F & G;
 CLASS I ZONE 0 IIC & CLASS I ZONE 2 IIC/ ZONE 0 IIC & ZONE 2 IIC;
 CLASS I DIVISION 2, GROUPS A, B, C, D;

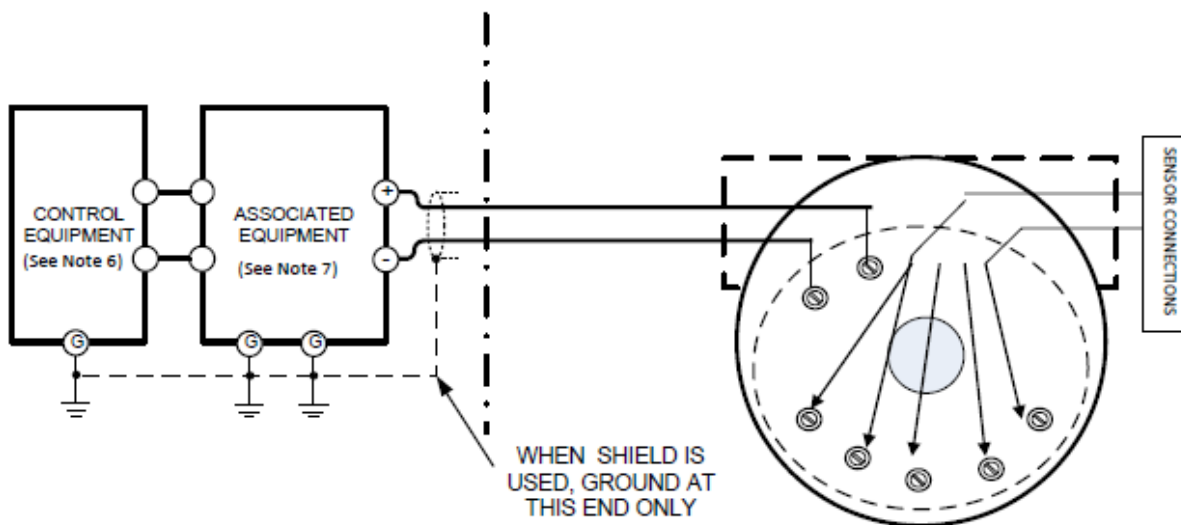

FOR NON INCENDIVE DIV 2 / NON SPARKING ZONE 2 INSTALLATIONS

CONTROL EQUIPMENT PARAMETERS
 Voltage= 35V, Current= 25 mA, $P_o \leq 1\text{ W}$
 NOTE : ASSOCIATED EQUIPMENT NOT REQUIRED
 EXCLUDING NON INCENDIVE FIELD WIRING (NIFW).

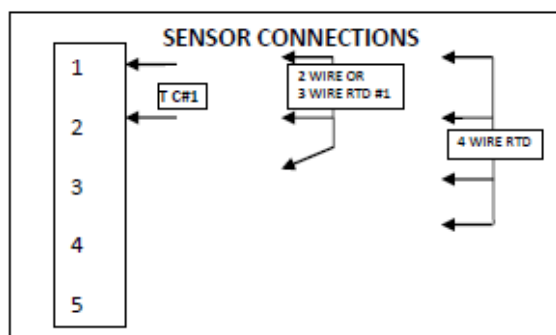

Honeywell

A/A4

50133855

SCALE: None REV A DATE 5/9/2017 SH. 2 of 4

STT700 HART/DE with LP, no EU Meter

Terminal	ENTITY PARAMETERS (Divisions and Zones Ex ia and Ex ic)	Associated Apparatus
1,2 (Loop)	U_i or $V_{max} = 30V$	U_o, V_{oc} or $V_t \leq 30V$
	i_i or $I_{max} = 225\text{ mA}$	I_o (I_{sc} or I_t) $\leq 225\text{ mA}$
	P_i or $P_{max} = 0.9W$	$P_o \leq 0.9\text{ W}$
	$C_i = 16\text{ nF}$	C_a or $C_o \geq C_{cable} + C_{STT700}$
	$L_i = 0\text{ }\mu\text{H}$	L_a or $L_o \geq L_{cable} + L_{STT700}$
5, 6, 7, 8 (SENSOR)	$C_o = 36\text{ }\mu\text{F}$	----
	$L_o = 657\text{ }\mu\text{H}$	----

NON-HAZARDOUS LOCATION

HAZARDOUS (CLASSIFIED) LOCATION

CLASS I, CLASS II, and CLASS III DIVISION 1, GROUPS A, B, C, D, E, F & G;
CLASS I ZONE 0 IIC & CLASS I ZONE 2 IIC/ ZONE 0 IIC & ZONE 2 IIC;
CLASS I DIVISION 2, GROUPS A, B, C, D;

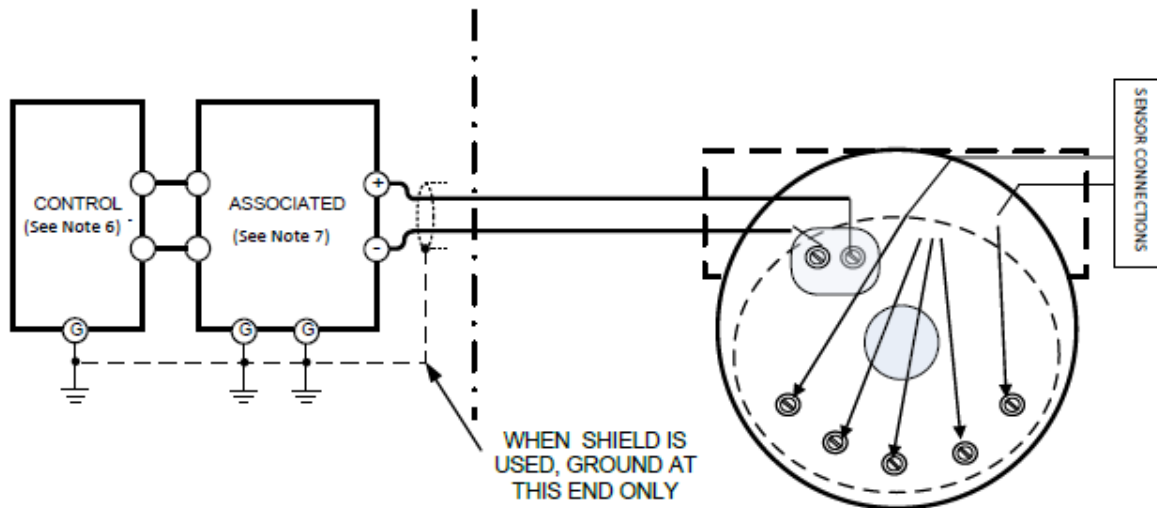

FOR NON INCENDIVE DIV 2 /
NON SPARKING ZONE 2
INSTALLATIONS

CONTROL EQUIPMENT PARAMETERS
Voltage= 35V, Current= 25 mA, $P_o \leq 1\text{ W}$
NOTE : ASSOCIATED EQUIPMENT NOT REQUIRED EXCLUDING
NON INCENDIVE FIELD WIRING (NIFW).

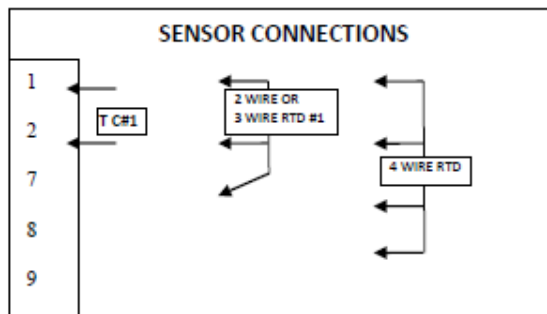

Honeywell

A/A4

50133855

SCALE: None

REV A

DATE 5/9/2017

SH. 3 of 4

STT700 HART/DE with LP, and EU Meter

Terminal	ENTITY PARAMETERS (Divisions and Zones Ex ia and Ex ic)	Associated Apparatus
1,2 (Terminal Strip)	U_i or $V_{max} = 30V$	U_o, V_{oc} or $V_t \leq 30V$
	I_i or $I_{max} = 225\text{ mA}$	I_o (I_{sc} or I_t) $\leq 225\text{ mA}$
	P_i or $P_{max} = 0.9W$	$P_o \leq 0.9\text{ W}$
	$C_i = 16\text{ nF}$	C_a or $C_o \geq C_{cable} + C_{STT700}$
	$L_i = 0\text{ }\mu H$	L_a or $L_o \geq L_{cable} + L_{STT700}$
5, 6, 7, 8 (SENSOR)	$C_o = 36\text{ }\mu F$	----
	$L_o = 657\text{ }\mu H$	----

NON-HAZARDOUS LOCATION

HAZARDOUS (CLASSIFIED) LOCATION

CLASS I, CLASS II, and CLASS III DIVISION 1, GROUPS A, B, C, D, E, F & G;
 CLASS I ZONE 0 IIC & CLASS I ZONE 2 IIC/ ZONE 0 IIC & ZONE 2 IIC;
 CLASS I DIVISION 2, GROUPS A, B, C, D;

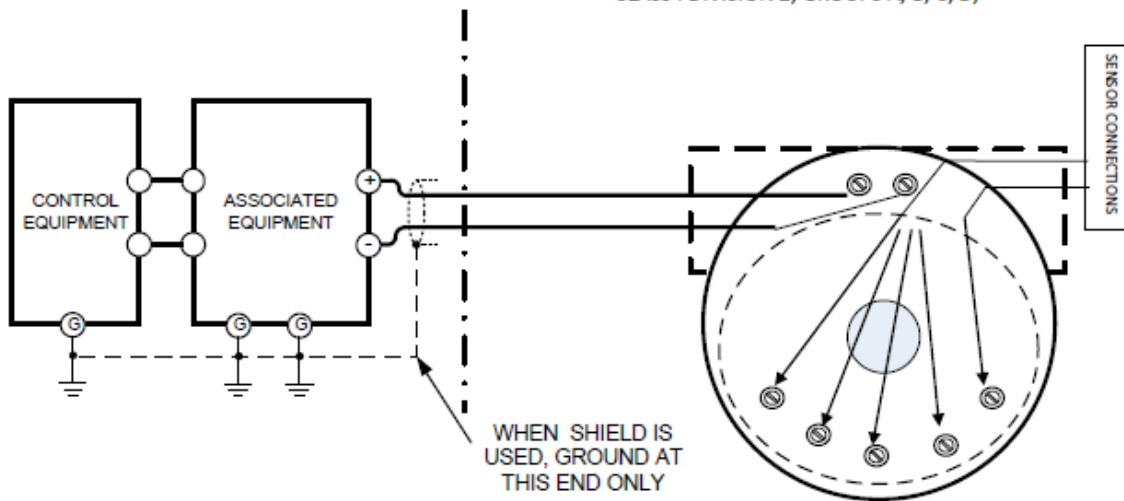

FOR NON INCENDIVE DIV 2 /
 NON SPARKING ZONE 2
 INSTALLATIONS

CONTROL EQUIPMENT PARAMETERS
 Voltage= 35V, Current= 25 mA, $P_o \leq 1\text{ W}$

NOTE : ASSOCIATED EQUIPMENT NOT REQUIRED EXCLUDING
 NON INCENDIVE FIELD WIRING (NIFW).

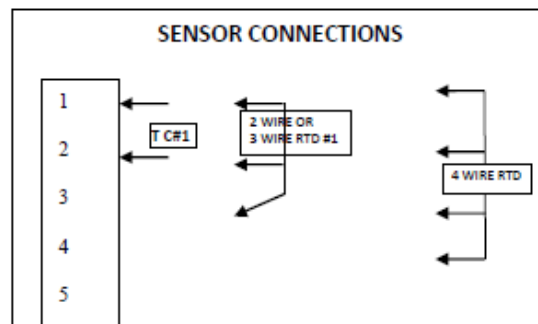

Honeywell

A/A4

50133855

SCALE: None

REV A

DATE 5/9/2017

SH. 4 of 4

Glossary

AWG	American Wire Gauge
C/J	Cold Junction
CVD	Callendar-Van Dusen is an equation that describe the relationship between resistance (R) and temperature (t) of platinum resistance thermometers (RTD)
DD	Device Description
DE	Digital Enhanced Communications Mode
DTM	Device Type Manager
EMI	Electromagnetic Interference
EEPROM	Electrically Erasable Programmable Read Only Memory
FDM	Field Device Manager
FTA	Field Termination Assembly
HART	Highway Addressable Remote Transducer
HCF	HART Communication Foundation
Hz	Hertz
LRL	Lower Range Limit
LRV	Lower Range Value
mAdc	Milliamperes Direct Current
MCT	MC Toolkit
mV	Millivolts
Nm	Newton meters
NPT	National Pipe Thread
NVM	Non-Volatile Memory
PM	Process Manager
PV	Process Variable
PWA	Printed Wiring Assembly
RFI	Radio Frequency Interference
RTD	Resistance Temperature Detector
SCT	SmartLine Configuration Toolkit
SFC	Smart Field Communicator
STIM	Temperature Transmitter Interface Module
STIMV IOP	Temperature Transmitter Interface Multivariable Input/Output Processor
T	Temperature

T/C	Thermocouple
URL	Upper Range Limit
URV	Upper Range Value
US	Universal Station
Vac	Volts Alternating Current
Vdc	Volts Direct Current
WAO	WRITE AS ONE (grouping of parameters for editing, for example you can edit PV URV and PV LRV in one shot if URV LRV is provided under wao list)

Index

<p style="text-align: center;">A</p> <p>About This Manualiii</p> <p>Accuracy 5</p> <p>Application Design 5</p> <p style="text-align: center;">C</p> <p>Copyrights, Notices and Trademarks ii</p> <p style="text-align: center;">D</p> <p>Diagnostic Messages 5</p> <p>Display Options..... 4</p> <p style="text-align: center;">F</p> <p>Features and Options..... 1</p> <p style="padding-left: 20px;">Functional Characteristics3</p> <p style="padding-left: 20px;">Physical Characteristics1</p> <p style="text-align: center;">G</p> <p>Glossary.....52</p> <p style="text-align: center;">H</p> <p>Honeywell MC Toolkit..... 9</p> <p style="text-align: center;">I</p> <p>Installation and Startup 9</p> <p style="padding-left: 20px;">Display Installation Precautions9</p> <p style="padding-left: 20px;">Mounting STT850 Temperature Transmitters.....9</p> <p style="padding-left: 20px;">Site evaluation9</p> <p style="padding-left: 40px;">Installation Site Evaluation</p> <p style="padding-left: 20px;">Site Evaluation9</p> <p>Introduction 1</p> <p style="text-align: center;">M</p> <p>Maintenance29</p> <p style="padding-left: 20px;">Preventive Maintenance Practices and Schedules...29</p> <p style="padding-left: 20px;">Replacing the Communication Module.....29</p>	<p>Mounting STT850 Temperature Transmitters 10</p> <p style="padding-left: 20px;">Mounting Dimentsions 10</p> <p style="padding-left: 20px;">Summary 10</p> <p style="text-align: center;">N</p> <p>Name Plate 3</p> <p style="text-align: center;">O</p> <p>Operation 26</p> <p style="text-align: center;">P</p> <p>Patent Notice iv</p> <p style="text-align: center;">R</p> <p>References iv</p> <p>Release Information..... iii</p> <p style="text-align: center;">S</p> <p style="text-align: center;">Safety</p> <p style="padding-left: 20px;">Safety Integrity Level 5</p> <p>Safety Certification..... 4</p> <p>Startup..... 24</p> <p style="padding-left: 20px;">Constant Current Source Mode Procedure 25</p> <p style="padding-left: 20px;">Output Check Procedures..... 24</p> <p>Support and Contact Information iv</p> <p>Symbol Descriptions and Definitions v</p> <p style="text-align: center;">T</p> <p>Telephone and Email Contacts iv</p> <p style="padding-left: 20px;">Temperature, Analog, HART and DE</p> <p style="padding-left: 20px;">Communication 36</p> <p>Transmitter Adjustments 4</p> <p style="text-align: center;">W</p> <p>Wiring a Transmitter 16</p> <p style="padding-left: 20px;">Wiring Variations..... 18</p>
---	---

Sales and Service

For application assistance, current specifications, pricing, or name of the nearest Authorized Distributor, contact one of the offices below.

ASIA PACIFIC

Honeywell Process Solutions,
(TAC) hfs-tac-support@honeywell.com

Australia

Honeywell Limited
Phone: +(61) 7-3846 1255
FAX: +(61) 7-3840 6481
Toll Free 1300-36-39-36
Toll Free Fax:
1300-36-04-70

China – PRC - Shanghai

Honeywell China Inc.
Phone: (86-21) 5257-4568
Fax: (86-21) 6237-2826

Singapore

Honeywell Pte Ltd.
Phone: +(65) 6580 3278
Fax: +(65) 6445-3033

South Korea

Honeywell Korea Co Ltd
Phone: +(822) 799 6114
Fax: +(822) 792 9015

EMEA

Honeywell Process Solutions,
Phone: + 80012026455 or
+44 (0)1344 656000

Email: (Sales)

FP-Sales-Apps@Honeywell.com

or

(TAC)

hfs-tac-support@honeywell.com

AMERICA'S

Honeywell Process Solutions,
Phone: (TAC) 1-800-423-9883 or
215/641-3610
(Sales) 1-800-343-0228

Email: (Sales)

FP-Sales-Apps@Honeywell.com

or

(TAC)

hfs-tac-support@honeywell.com



Honeywell

AUTHORIZED DISTRIBUTOR

De Gidts & Feldman BV
The Netherlands
www.dgfg.nl



De Gidts & Feldman

INSTRUMENTATION & FILTRATION

For more information
To learn more about SmartLine transmitters,
visit www.honeywellprocess.com
Or contact your Honeywell Account Manager

Process Solutions
Honeywell
1250 W Sam Houston Pkwy S
Houston, TX 77042

Honeywell Control Systems Ltd
Honeywell House, Skimped Hill Lane
Bracknell, England, RG12 1EB

Shanghai City Centre, 100 Jungi Road
Shanghai, China 20061

www.honeywellprocess.com

Honeywell

34-TT-25-17 Rev.1
July 2017

©2017 Honeywell International Inc.