



VERSAFLOW SONIC 1000/TWS 9000 **Handbook**

Ultrasonic clamp-on flowmeter

Notices and Trademarks

Copyright 2007 by Honeywell

WARRANTY/REMEDY

Honeywell warrants goods of its manufacture as being free of defective materials and faulty workmanship. Contact your local sales office for warranty information. If warranted goods are returned to Honeywell during the period of coverage, Honeywell will repair or replace without charge those items it finds defective. The foregoing is Buyer's sole remedy and is in lieu of all other warranties, expressed or implied, including those of merchantability and fitness for a particular purpose. Specifications may change without notice. The information we supply is believed to be accurate and reliable as of this printing. However, we assume no responsibility for its use.

While we provide application assistance personally, through our literature and the Honeywell web site, it is up to the customer to determine the suitability of the product in the application.

Honeywell Field Solutions
512 Virginia Drive
Fort Washington, PA 19034

Abstract

This document provides descriptions and procedures for the Installation, Configuration, Operation, and Troubleshooting of your device.

Contacts

World Wide Web:

The following lists Honeywell’s World Wide Web sites that will be of interest to our customers.

Honeywell Organization

WWW Address (URL)

Corporate

<http://www.honeywell.com>

Field Solutions

<http://www.honeywell.com/ps>

Technical tips

<http://content.honeywell.com/ipc/faq>

Telephone:

Contact us by telephone at the numbers listed below.

Organization

Phone Number

United States and
Canada

Honeywell

Tech. Support: 1-800-423-9883
Service: 1-800-525-7439

1	Safety instructions.....	8
1.1	Intended use.....	8
1.2	Certification.....	8
1.3	Safety instructions from the manufacturer.....	8
1.3.1	Disclaimer.....	8
1.3.2	Product liability and warranty.....	9
1.3.3	Information concerning the documentation.....	9
1.3.4	Display conventions.....	10
1.4	Safety instructions for the operator.....	10
2	Instrument description.....	12
2.1	Scope of delivery.....	12
2.2	Instrument description.....	13
2.3	Nameplate.....	14
2.3.1	VersaFlow Sonic 1000.....	14
2.3.2	TWS 9000 Signal converter.....	15
2.3.3	Coding for I/O assemblies.....	16
3	Installation.....	18
3.1	Pre-installation requirements.....	18
3.1.1	Environmental requirements.....	18
3.1.2	Installation requirements.....	18
3.2	General installation notes.....	19
3.3	Storage.....	19
3.4	Transport.....	19
3.5	Installation requirements.....	19
3.5.1	Inlet, outlet and recommended mounting area.....	20
3.5.2	Long horizontal pipes.....	20
3.5.3	Open feed or discharge.....	21
3.5.4	Down going pipeline over 5 m /16 ft length.....	21
3.5.5	Position of control valve.....	22
3.5.6	Position of pump.....	22
3.5.7	Pipe diameters and sensor construction.....	23
3.6	Installation VersaFlow Sonic 1000 sensor.....	24
3.6.1	General mechanical installation.....	24
3.6.2	Installation instructions for small and medium version.....	27
3.6.3	Installation instructions for large version.....	29
3.7	Mounting of converter.....	31
3.7.1	Mounting of TWS 9000 F.....	31
3.7.2	Mounting of TWS 9000 W.....	31

4	Electrical connections	32
4.1	Safety instructions	32
4.2	Construction of the various housing versions	32
4.2.1	TWS 9000 F	32
4.2.2	TWS 9000 W	34
4.3	Electrical connection	35
4.3.1	Signal cable to flow sensor	35
4.3.2	Signal cable and power supply signal converter	36
4.4	Basic inputs and outputs	38
4.4.1	General	39
4.4.2	Electrical symbol description	40
4.4.3	Current output (analog)	41
4.4.4	Pulse output (digital)	41
4.4.5	Status output (digital)	42
4.4.6	Control input (digital)	42
4.4.7	Connection via HART®	43
4.5	Modular Inputs and Outputs	44
4.5.1	Alterable I/Os	44
4.5.2	Current output active I_a (HART®)	45
4.5.3	Current output passive I_p (HART®)	45
4.5.4	Pulse / frequency output active P_a	46
4.5.5	Pulse / frequency output passive P_p	46
4.5.6	Status output / limit switch active S_a	47
4.5.7	Status output / limit switch passive S_p	47
4.5.8	Control input active C_a	48
4.5.9	Control input passive C_p	48
4.5.10	Connection via HART®	49
4.5.11	Pulse, frequency and status output / limit switch passive P_N / S_N to NAMUR EN 60947-5-6	50
4.5.12	Control input active C_N to NAMUR EN 60947-5-6	50
5	Start-up	52
5.1	General instructions for programming	52
5.2	Start measurement of small / medium version	56
5.3	Start measurement of large version	58
5.4	Mechanical installation for large version	60

6	Operation	70
6.1	Menu overview	70
6.2	Menu structure	71
6.2.1	Quick setup	71
6.2.2	Test	73
6.2.3	Setup	75
6.2.4	Customize settings	82
6.3	Function description	83
6.4	Error messages	91
7	Service	94
7.1	Periodic maintenance	94
7.1.1	Regreasing of transducers	94
7.2	Cleaning	95
7.3	Exchange of electronics unit	95
7.3.1	TWS 9000 F	96
7.3.2	TWS 9000 W	98
7.4	Replacing the mains fuse	101
7.4.1	TWS 9000 F	101
7.4.2	TWS 9000 W	102
7.5	Spare parts availability	103
7.6	Service availability	103
7.7	Returning the device to the manufacturer	104
7.7.1	General information	104
7.7.2	Form (for copying) to accompany a returned instrument	105
7.8	Disposal	105
8	Technical data	106
8.1	Technical data	106
8.2	Dimensions and weights	113
9	Contact	116

1.1 Intended use

The VersaFlow Sonic 1000 with TWS 9000 is an ultrasonic clamp-on flowmeter that can be fitted on the outside of piping to measure the flow rate of liquids.

The VersaFlow Sonic 1000 with TWS 9000 is a combination of one up to two VersaFlow Sonic 1000 Clamp-on sensor(s) and one TWS 9000 ultrasonic flow converter.

The overall functionality of the VersaFlow Sonic 1000 with TWS 9000 clamp-on flowmeter is the continuous measurement of actual volume flow, mass flow, flow speed, velocity of sound, gain, SNR and diagnosis value.

1.2 Certification



In accordance with the commitment to customer service and safety, the VersaFlow Sonic 1000 with TWS 9000 clamp-on flowmeter, described in this handbook meets the following safety requirements:

- EMC Directive 89 / 336 / EEC and 93 / 68 / EEC in conjunction with EN 61326-1 (1997) and A1 (1998), A2 (2001)
- Low-Voltage Directives 73 / 23 / EEC and 93 / 68 / EEC in conjunction with EN 61010-1: 2001

All devices are based on the CE marking and meet the requirements of NAMUR Guideline NE 21 / 04 with TWS 9000 signal converter.

1.3 Safety instructions from the manufacturer

1.3.1 Disclaimer

The manufacturer will not be liable for any damage of any kind by using its product, including, but not limited to direct, indirect, incidental, punitive and consequential damages.

This disclaimer does not apply in case the manufacturer has acted on purpose or with gross negligence. In the event any applicable law does not allow such limitations on implied warranties or the exclusion of limitation of certain damages, you may, if such law applies to you, not be subject to some or all of the above disclaimer, exclusions or limitations.

Any product purchased from the manufacturer is warranted in accordance with the relevant product documentation and our Terms and Conditions of Sale.

The manufacturer reserves the right to alter the content of its documents, including this disclaimer in any way, at any time, for any reason, without prior notification, and will not be liable in any way for possible consequences of such changes.

1.3.2 Product liability and warranty

Ultrasonic flowmeters are designed solely for measuring the flow rate and the velocity of sound of process liquids.

Responsibility as to suitability and intended use of these ultrasonic flowmeters rests solely with the operator. The supplier does not accept any liability resulting from misuse by the operator. Improper installation and operation of the flowmeters (systems) may lead to loss of warranty. In addition, the "General conditions of sale" which forms the basis of the purchase agreement are applicable.

1.3.3 Information concerning the documentation

To prevent any injury to the user or damage to the device it is essential that you read the information in this document and observe applicable national standards, safety requirements and accident prevention regulations.

If this document is not in your native language and if you have any problems understanding the text, we advise you to contact your local the manufacturer office for assistance. The manufacturer can not accept responsibility for any damage or injury caused by misunderstanding of the information in this document.

This document is provided to help you establish operating conditions, which will permit safe and efficient use of this device. Special considerations and precautions are also described in the document, which appear in the form of underneath icons.

1.3.4 Display conventions

The following symbols are used to help you navigate this documentation more easily:

**WARNING!**

These warning signs must be observed without fail. Even only partial disregarding such warnings can result in serious health damage, damage to the device itself or to parts of the operator's plant.

**DANGER!**

This symbol designates safety advice on handling electricity.

**CAUTION!**

These warnings must be observed without fail. Even only partial disregarding such warnings can lead to improper functioning of the device.

**LEGAL NOTICE!**

This symbol designates information on statutory directives and standards.

**NOTE!**

This symbol designates important information for the handling of the device.

**HANDLING**

This symbol designates all instructions for actions to be carried out by the operator in the specified sequence.

**CONSEQUENCE**

This symbol designates all important consequences of the previous actions.

1.4 Safety instructions for the operator

**WARNING!**

*In general, devices from the manufacturer may only be installed, commissioned, operated and maintained by properly trained and authorized personnel.
This document is provided to help you establish operating conditions, which will permit safe and efficient use of this device.*

2.1 Scope of delivery



INFORMATION!

Check the packing list to see if you have received all that you require.

The VersaFlow Sonic 1000 with TWS 9000 will arrive in two cartons. The square carton contains the TWS 9000 converter. The rectangular carton contains the VersaFlow Sonic 1000 transducer set.



NOTE!

Inspect the cartons carefully for damage or signs of rough handling. Report damage to the carrier and to your local office.

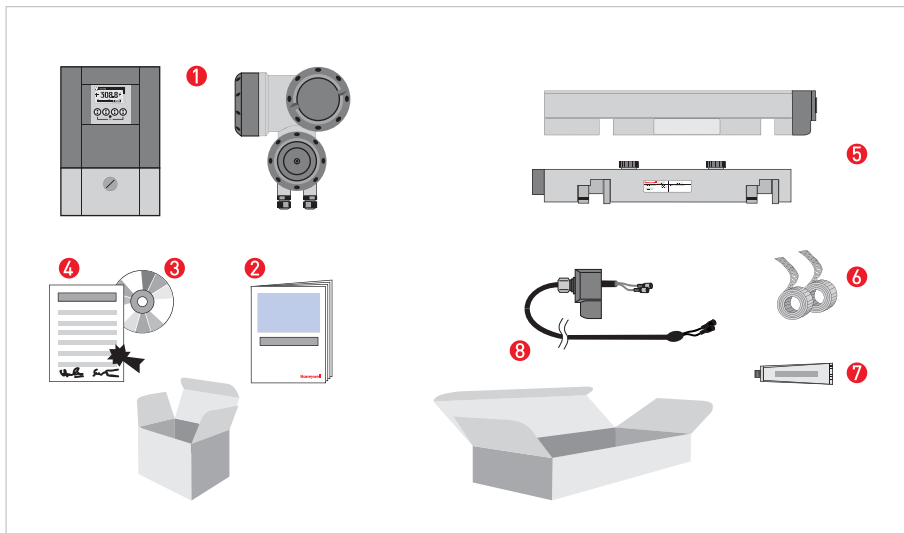


Figure 2-1: Scope of delivery

- 1 Signal converter, wall version or field version
- 2 Quick Start
- 3 CD-ROM (including Handbook, Quick Start, Technical Datasheet, Support database, movie)
- 4 Factory calibration report
- 5 Sensor plus cover
- 6 Metal strap
- 7 Mineral coupling grease
- 8 Signal cable plus connector cap

Additionally for large version:

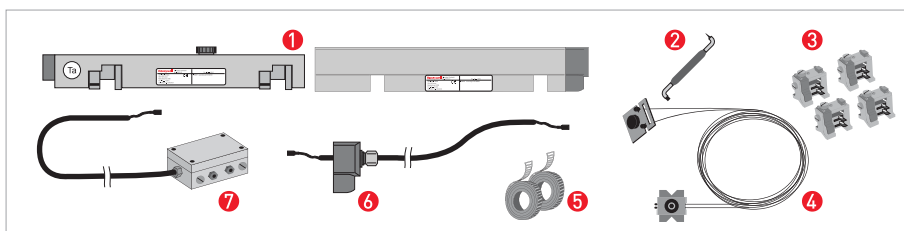


Figure 2-2: Additionally for large version



INFORMATION!
No special tools, no training required!

2.2 Instrument description

The VersaFlow Sonic 1000 with TWS 9000 is an ultrasonic clamp-on flowmeter that can be fitted on the outside of piping to measure the flow rate of liquids.

The VersaFlow Sonic 1000 with TWS 9000 is a combination of one up to two VersaFlow Sonic 1000 Clamp-on sensor(s) and one TWS 9000 ultrasonic flow converter.

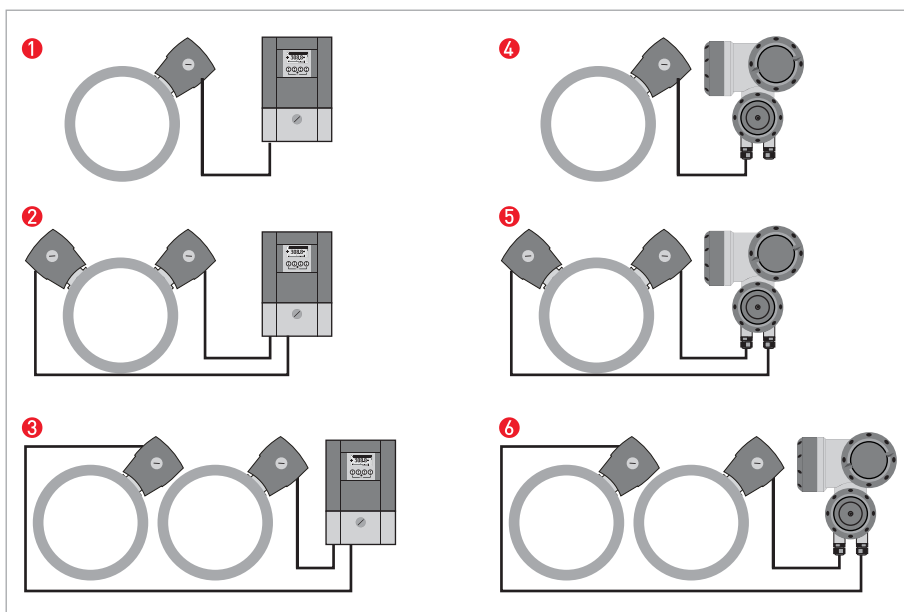


Figure 2-3: System configuration possibilities

For the VersaFlow Sonic 1000 with TWS 9000 underneath accessories can be ordered optionally:

- GDC interface set
- SoundCheck
- Coupling grease; mineral

2.3 Nameplate

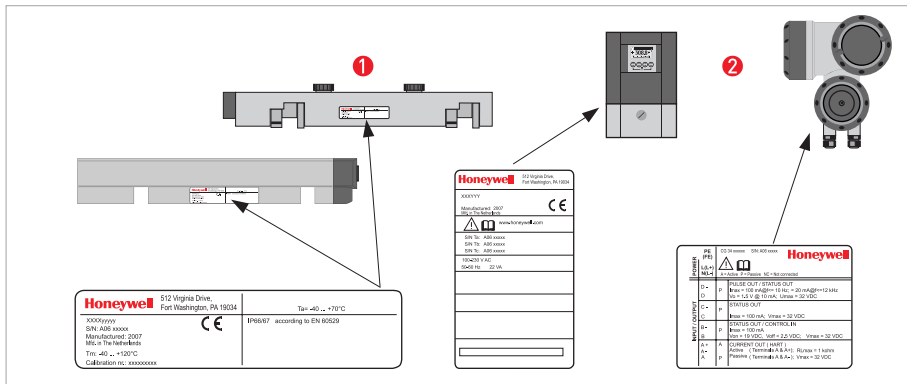


Figure 2-4: Visual check

- 1 VersaFlow Sonic 1000 flow sensor
- 2 TWS 9000 signal converter



NOTE!

Please check on the device nameplates, that the device is supplied according to your order. Check for the correct mains voltage printed on the nameplate. If not, contact your local representative for advice.

2.3.1 VersaFlow Sonic 1000

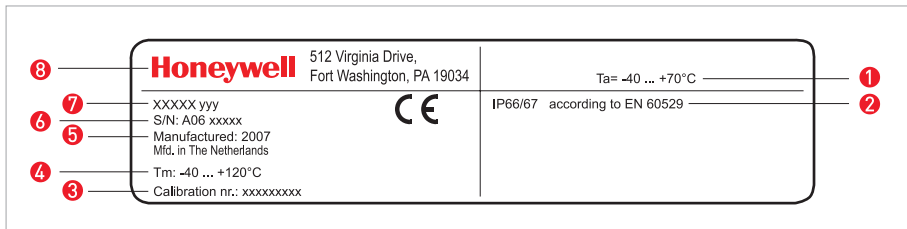


Figure 2-5: Nameplate VersaFlow Sonic 1000 - rail

- 1 Ambient temperature operating range
- 2 Protection category
- 3 Calibration number
- 4 Process temperature
- 5 Manufacturing year
- 6 Serial number
- 7 Device type (yyy = small, medium or large)
- 8 Manufacturer

2.3.2 TWS 9000 Signal converter

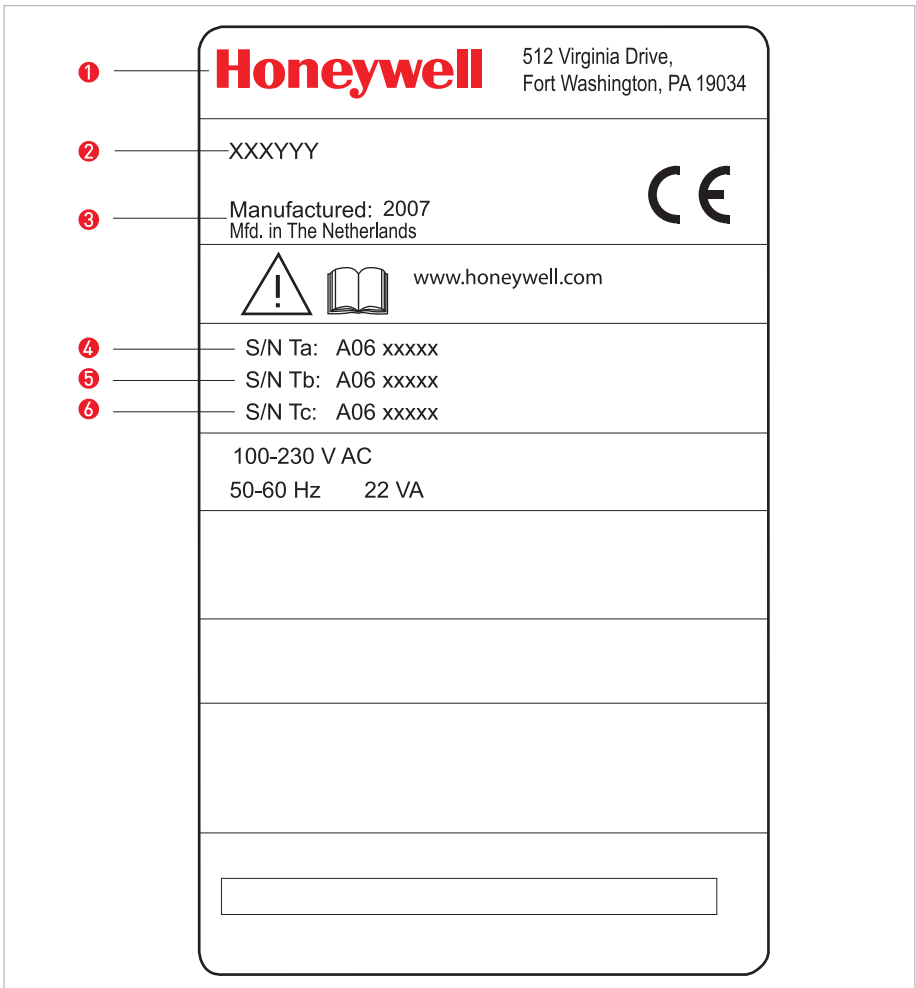


Figure 2-6: Nameplate TWS 9000

- ① Manufacturer
- ② Device type
- ③ Manufacturing year
- ④ Serial number sensor 1 + short code flow sensor
- ⑤ Serial number sensor 2 + short code flow sensor
- ⑥ Empty

2.3.3 Coding for I/O assemblies



POWER		PE (FE)	CG 34 xxxxxx S/N: A06 xxxxx	Honeywell
		L(L+) N(L-)	  A = Active P = Passive NC = Not connected	
INPUT / OUTPUT		D - D	P	PULSE OUT / STATUS OUT I _{max} = 100 mA@f<= 10 Hz; = 20 mA@f<=12 kHz V _o = 1.5 V @ 10 mA; U _{max} = 32 VDC
		C - C	P	STATUS OUT I _{max} = 100 mA; V _{max} = 32 VDC
		B - B	P	STATUS OUT / CONTROL IN I _{max} = 100 mA V _{on} > 19 VDC, V _{off} < 2.5 VDC; V _{max} = 32 VDC
		A + A - A	A P	CURRENT OUT (HART) Active (Terminals A & A+); R _{Lmax} = 1 kohm Passive (Terminals A & A-); V _{max} = 32 VDC

Figure 2-7: Nameplate inputs / outputs

3.1 Pre-installation requirements

**NOTE!**

To assure a quick, safe and uncomplicated installation, we kindly request you to make provisions as stated below.

3.1.1 Environmental requirements

- Pollution degree 2
- Protection class I
- Humidity: 5...80 % RH
- Temperature: -40...+60°C / -40...+140°F operating and -50...+70°C / -58...+158°F storage
- Suitable for indoor and outdoor use and certified for operating up to an altitude of 2000 m / 6562 ft
- IP class 66/67

**CAUTION!**

The device should be protected from corrosive chemicals or gases and dust / particles accumulation.

3.1.2 Installation requirements

- Allow 10...20 cm / 3.9...7.9" of space at the sides and rear of the signal converter to permit free air circulation.
- Protect signal converter against direct solar radiation, install a sunshield if necessary.
- Signal converters installed in switchgear cabinets require adequate cooling, e.g. by fan or heat exchanger.
- Do not expose the signal converter to intense vibration.

**NOTE!**

For detailed information please also refer to Dimensions and weights on page 113.

3.2 General installation notes



Check the following before you install the flowmeter:

- Check the packing and the flowmeter itself for any damage.
- Compare your order specification with the scope of delivery.
- Check nameplates on the flow sensor and the signal converter.

3.3 Storage

- Store the flowmeter in a dry and dust-free location.
- Avoid lasting direct exposure to the sun.
- Store the flowmeter in its original packing.

3.4 Transport

No special requirements.

3.5 Installation requirements



NOTE!

To avoid measuring errors and malfunctioning of the flowmeter due to gas or air inclusions or an empty pipe, please observe the following precautions.



CAUTION!

Since gas will collect at the highest point of a pipe, installation of the flowmeter at that location should be avoided at all times. Also installation in a down going pipe should be avoided since a completely filled pipe may not be guaranteed due to cascading effects. Additionally flow profile distortion is possible.

3.5.1 Inlet, outlet and recommended mounting area

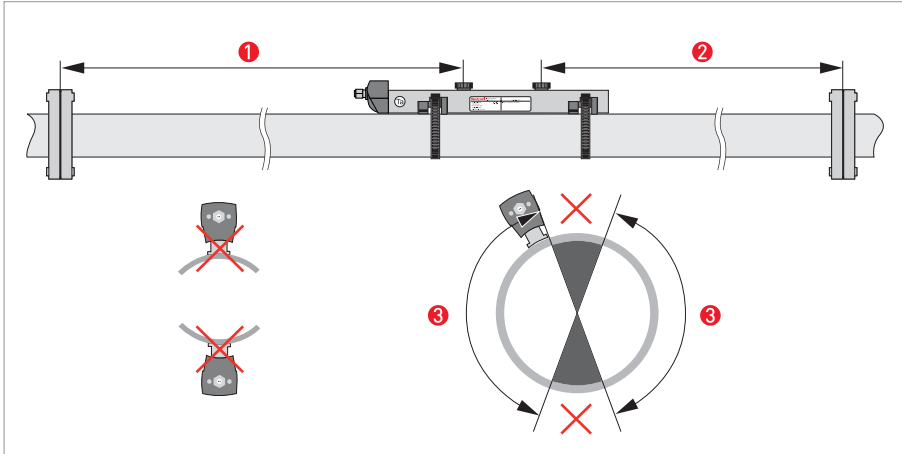


Figure 3-1: Inlet, outlet and recommended mounting area

- ① Min. 10 DN
- ② Min. 5 DN
- ③ OK, 120°

3.5.2 Long horizontal pipes

- Install on slightly ascending pipe section.
- If not possible, ensure adequate velocity to prevent air, gas or vapor from collecting in upper part.
- In partially filled pipes, the clamp-on flowmeter will report incorrect flow rates, or not measure.

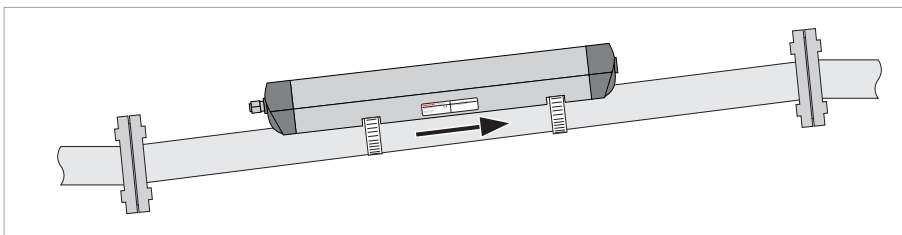


Figure 3-2: Long horizontal pipes

3.5.3 Open feed or discharge

Install meter on a lowered section of the pipe to ensure a full pipe condition through the meter.

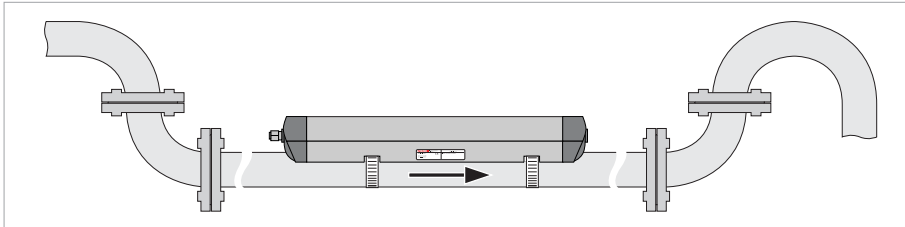


Figure 3-3: Open feed or discharge

3.5.4 Down going pipeline over 5 m /16 ft length

Install air vent downstream of the flow meter to prevent vacuum. Although this will not harm the meter, it may cause gases to come out of solution (cavitate) and interfere with proper measurements.

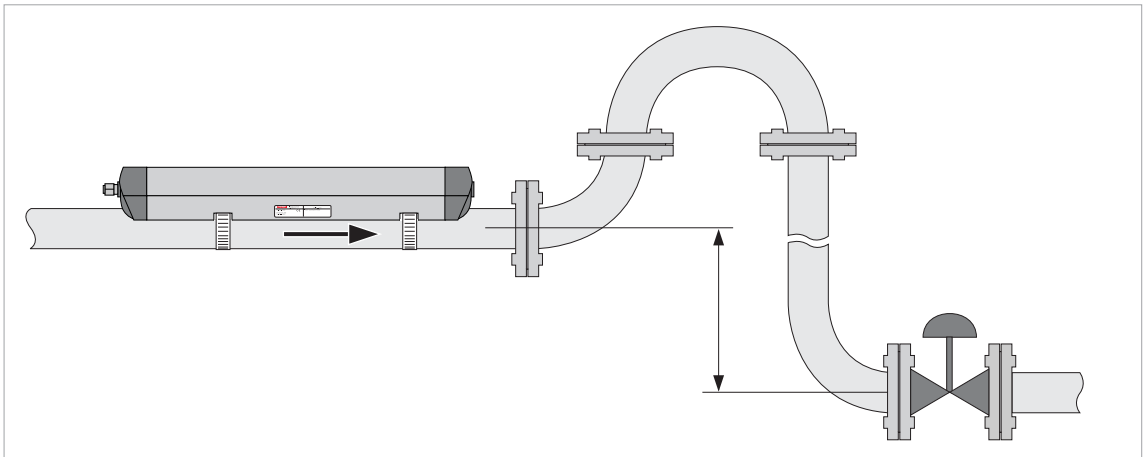


Figure 3-4: Down going pipeline over 5 m /16 ft length

3.5.5 Position of control valve

Always install control valves downstream of flowmeter in order to avoid cavitation or distortion of flow profile.

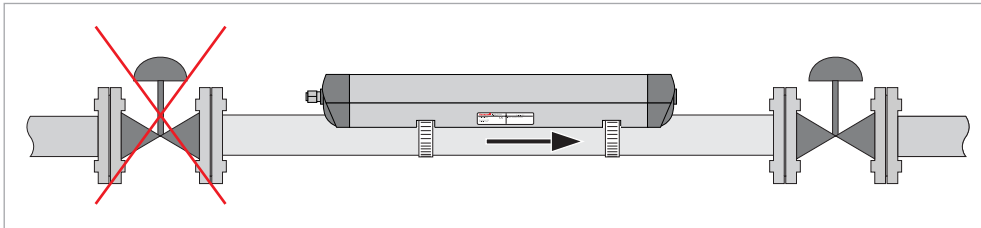


Figure 3-5: Position of control valve

3.5.6 Position of pump



CAUTION!

Never install flowmeter at a pump suction side in order to avoid cavitation or flashing in the flowmeter.

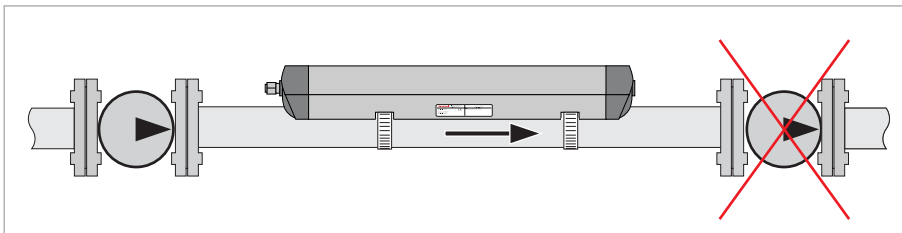


Figure 3-6: Position of pump

3.5.7 Pipe diameters and sensor construction

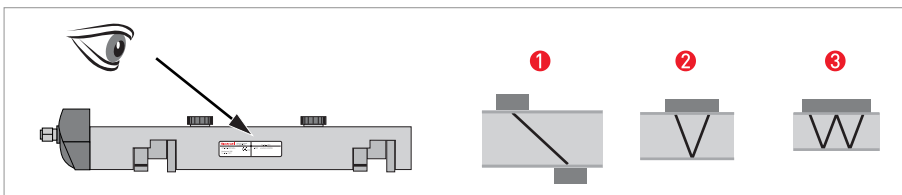


Figure 3-7: Measuring modes

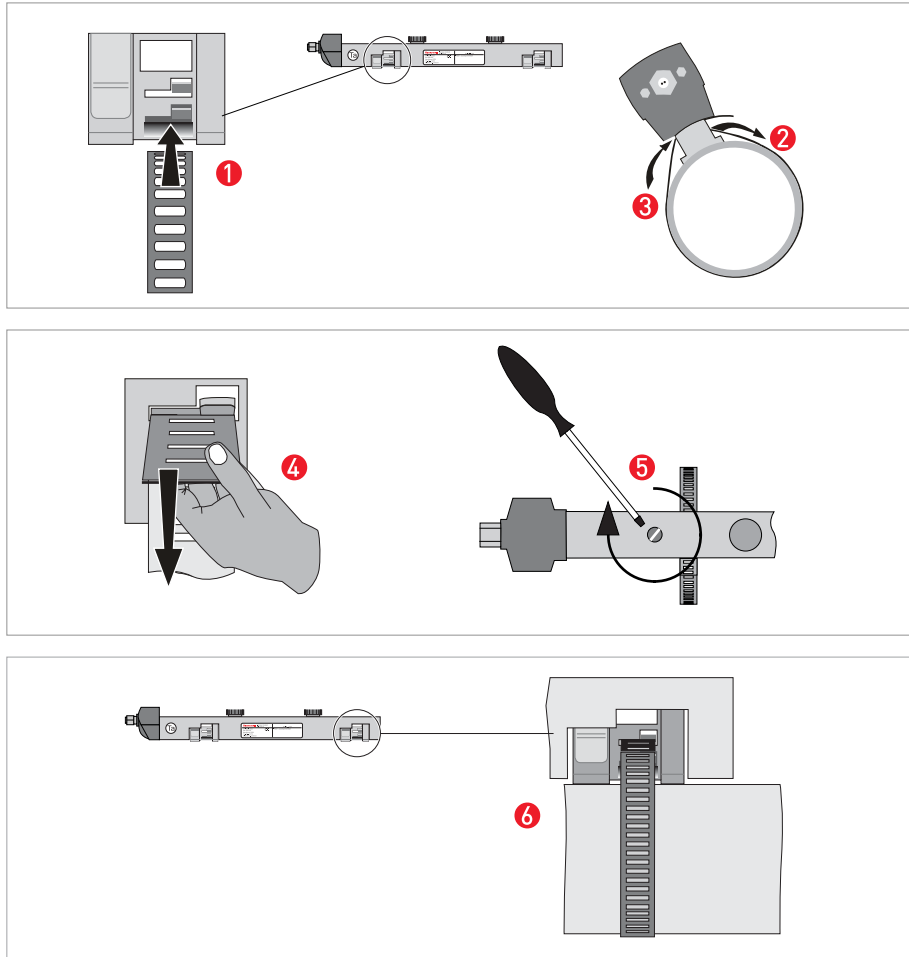
- 1 Z-mode
- 2 V-mode
- 3 W-mode

Rail version	Diameter range	Preferred measuring modes
Small	DN15...100 / 0.5...4"	< DN25: W-mode (4 traverses)
		≥ DN25: V-mode (2 traverses)
Medium	DN50...400 / 2...16"	V-mode (2 traverses)
Large	DN200...4000 / 8...160"	Z-mode (1 traverse)

3.6 Installation VersaFlow Sonic 1000 sensor

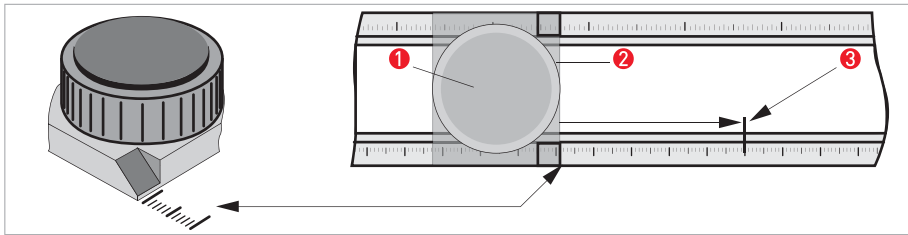
3.6.1 General mechanical installation

Installation of the rails with the metal straps



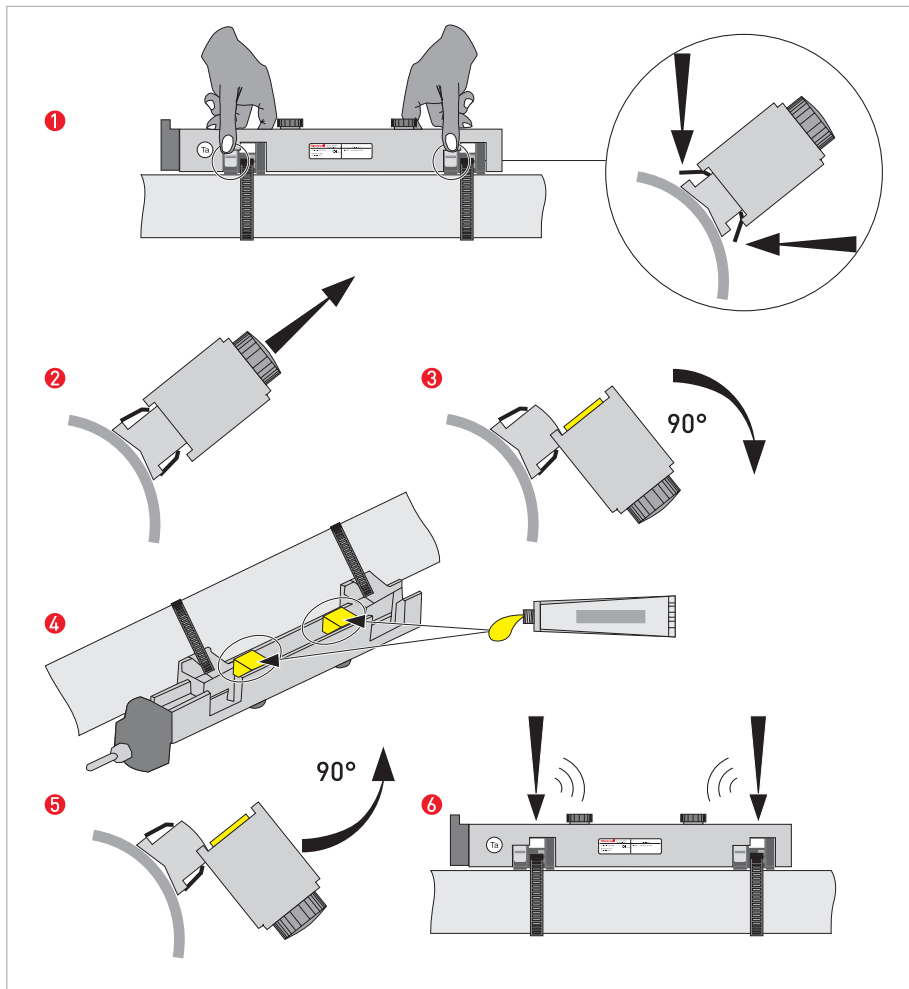
- 7: Repeat steps 1...6 at the other side of the rail.

Change the position of the transducer

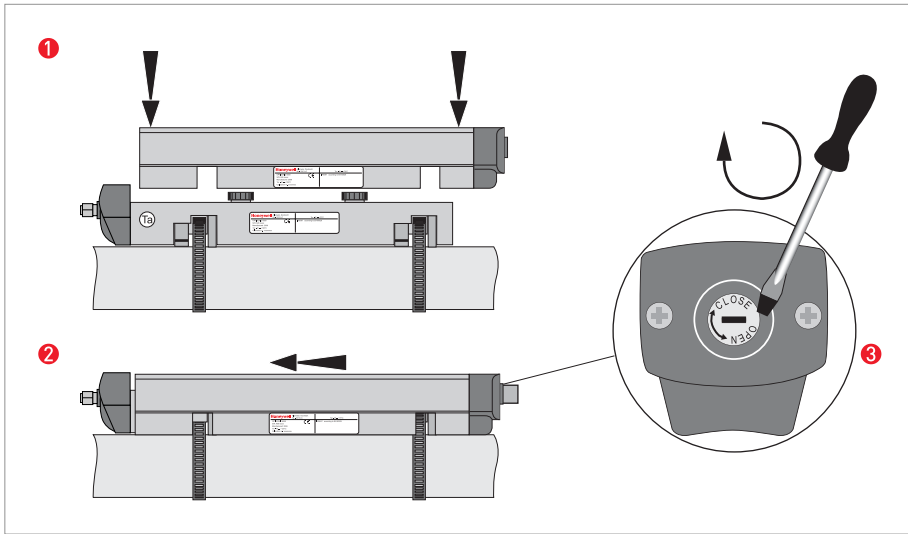


- Unlock the floating transducer **2** by turning the locking knob **1** counter clockwise.
- Slide the transducer **2** to the advised mounting distance **3** (menu X9.4).
- Lock the transducer by turning the locking knob **1** clockwise.

Greasing the transducer surfaces



Mounting the cover



3.6.2 Installation instructions for small and medium version

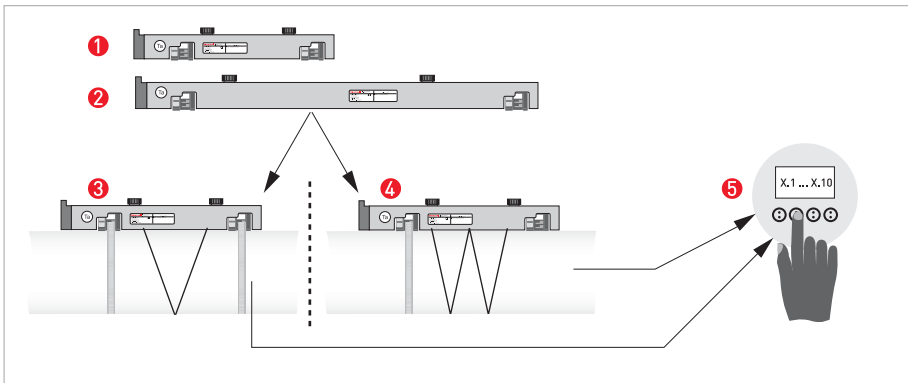


Figure 3-8: Procedure for installation of small or medium version

- 1 Rail, small version
- 2 Rail, medium version
- 3 Choose for V-mode or ...
- 4 Choose for W-mode
- 5 Make settings in converter

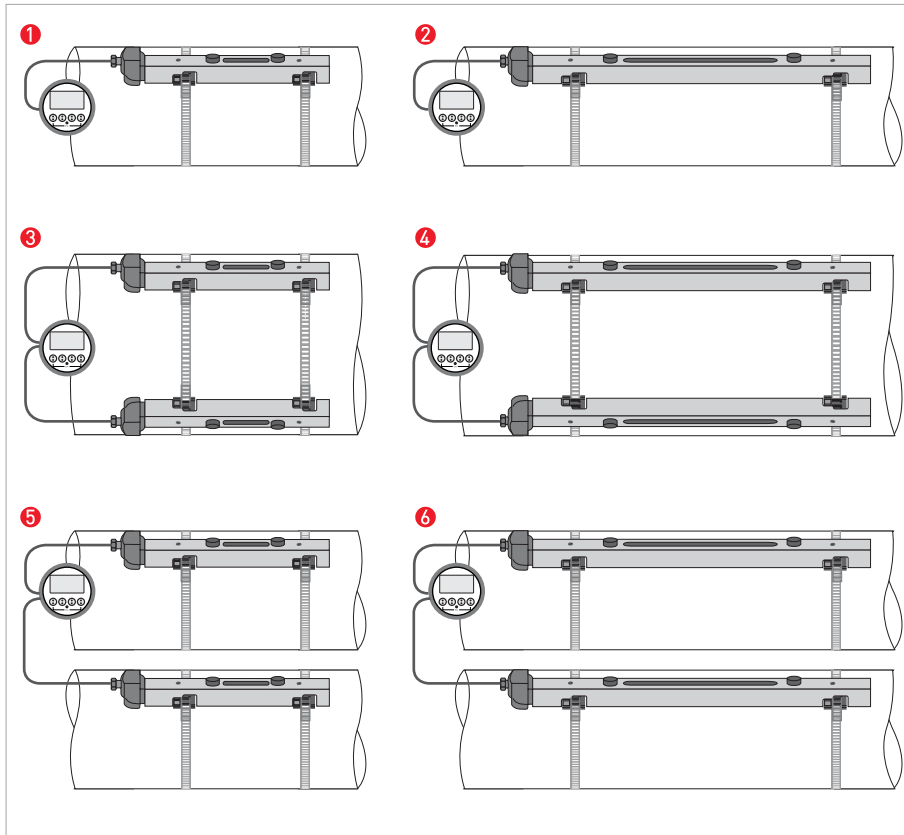


Figure 3-9: Instrument versions

- 1 Small version: single pipe / single path
- 2 Medium version: single pipe / single path
- 3 Small version: single pipe / dual path
- 4 Medium version: single pipe / dual path
- 5 Small version: dual pipe / single path
- 6 Medium version: dual pipe / single path

3.6.3 Installation instructions for large version

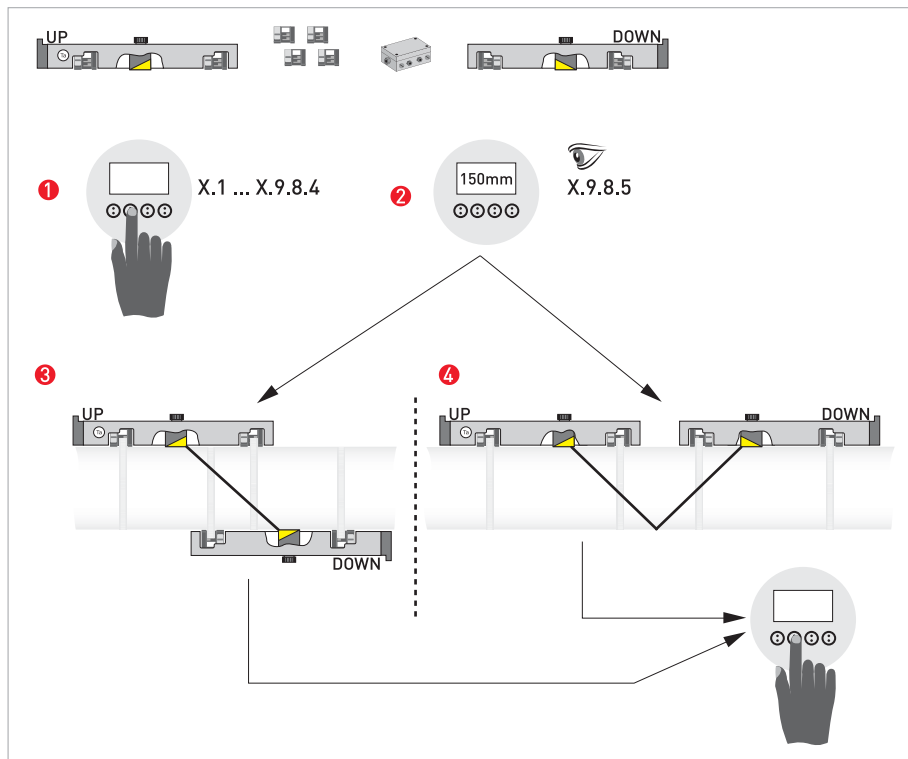


Figure 3-10: Procedure for installation of large version

- 1 Enter the values for the installation menu, X1...X9.8.4
- 2 Read the advised mounting distance in menu X9.8.5
- 3 Choose for Z-mode (default) or ...
- 4 Choose for V-mode
- 5 Finish the installation menu

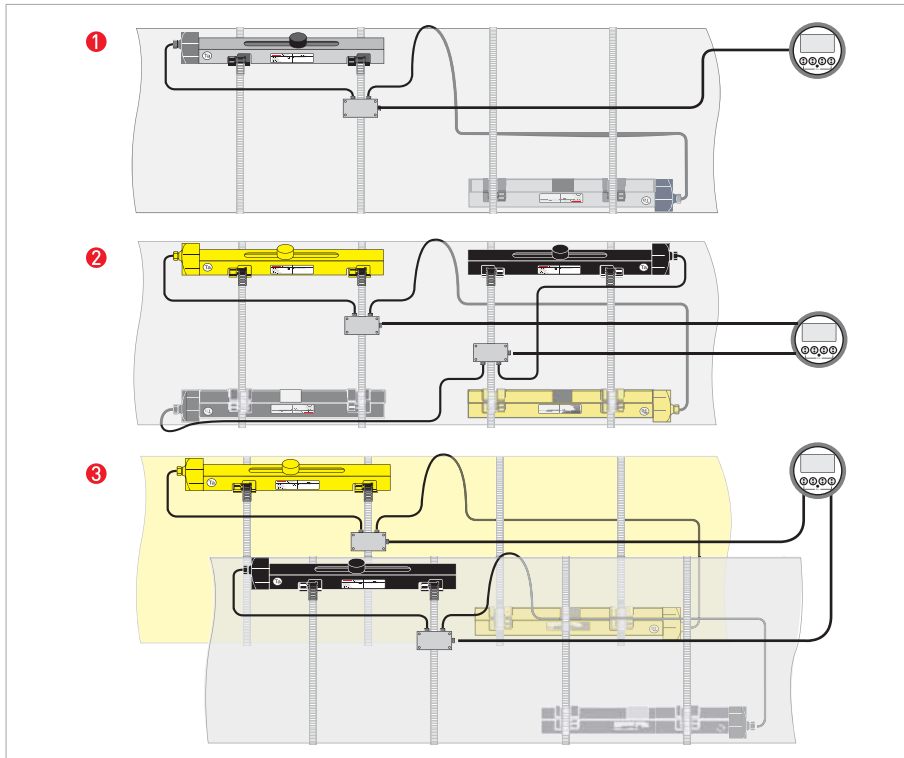


Figure 3-11: Instrument versions

- 1** Single pipe, single path
- 2** Single pipe, dual path
- 3** Dual pipe

3.7 Mounting of converter

**CAUTION!**

Always use the supplied signal cable. Keep the distance between the sensor and the signal converter as short as possible.

3.7.1 Mounting of TWS 9000 F



Perform the following procedures:

- Mount TWS 9000 F with mounting plate on wall or standpipe.
- Observe maximum allowed length of 30 m / 98.4 ft for the signal cable

3.7.2 Mounting of TWS 9000 W



Perform the following procedures:

- Remove aluminium mounting plate from rear of the signal converter, and attach to wall or standpipe.
- Mount signal converter.
- Position lock washers and nuts on the housing bolts, tighten nuts slightly.
- Align housing, tighten nuts firmly.
- Observe max. allowed length of 30 m / 98.4 ft for the signal cable.

4.1 Safety instructions



DANGER!

All work on the electrical connections may only be carried out with the power disconnected. Take note of the voltage data on the nameplate!



DANGER!

Observe national installation regulations!



WARNING!

Observe the regional occupational health and safety regulations without fail. Only work on the device electrics if you are appropriately trained.

4.2 Construction of the various housing versions

4.2.1 TWS 9000 F

The terminal compartments are accessible after unscrewing cover ② and ③.

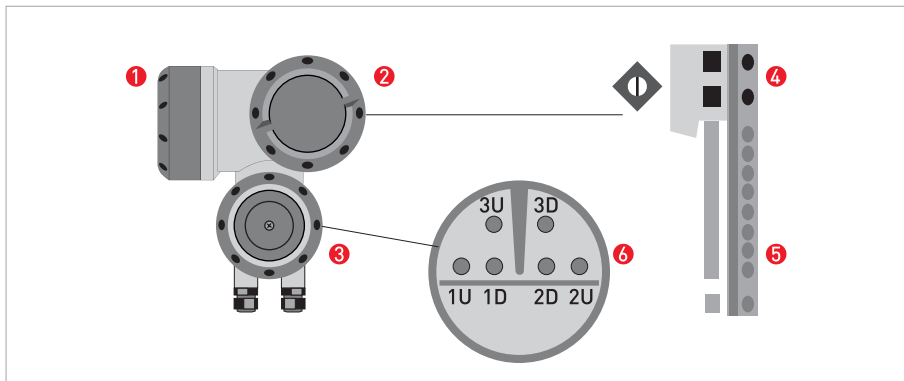


Figure 4-1: Construction of TWS 9000 F (field)

- ① Cover, electronics compartment
- ② Cover, terminal compartment for power supply and inputs/outputs
- ③ Cover, sensor terminal compartment
- ④ Cable entry for power
- ⑤ Cable entry for inputs/outputs
- ⑥ Cable entry for sensor cable

Turning display of TWS 9000 F

The display of the TWS 9000 F can be turned in steps of 90°.

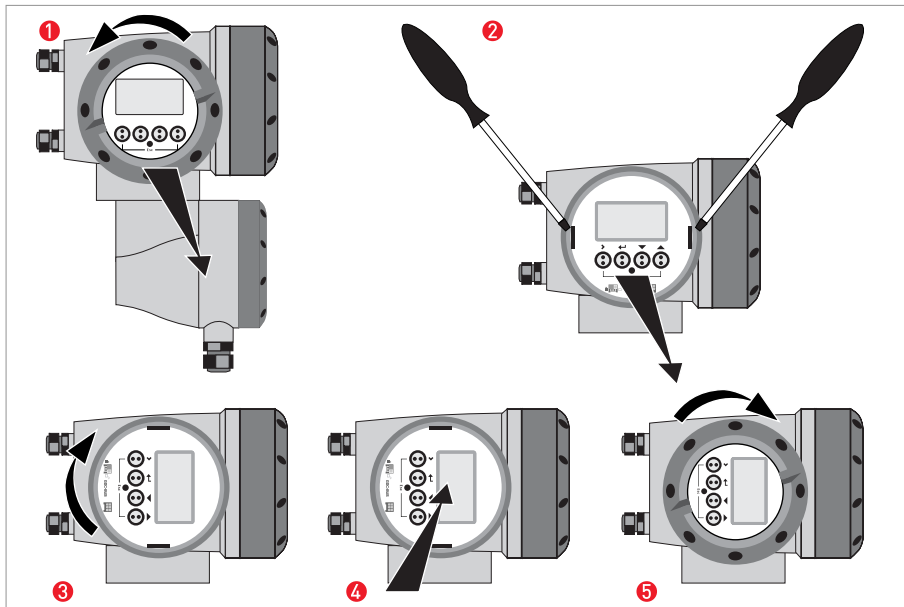


Figure 4-2: Turning display of (field)



To do this,

- Unscrew the cover of the electronics compartment ①.
- Pull the two metal clips to the left and right of the display ②, using a screwdriver or similar tool.
- The display between the metal clips can then be pulled off and re-inserted in the required position ③ and ④.
- Replace cover and tighten by hand ⑤.



CAUTION!

Before pushing back the clips simultaneously with the display onto the electronics, make sure not to kink the display's flat ribbon cable more than absolutely necessary.



NOTE!

Cover threads need to be protected from dirt and well greased at all times.

4.2.2 TWS 9000 W

The terminal compartments are accessible after opening cover ②.

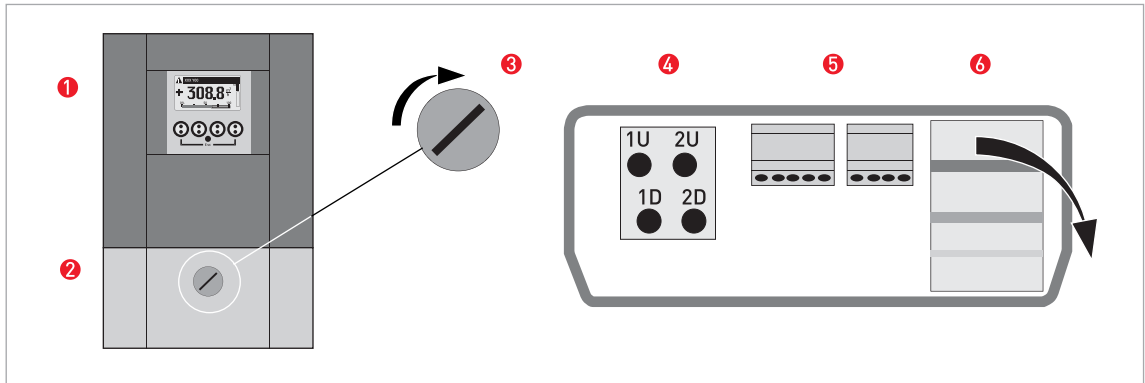


Figure 4-3: Construction of TWS 9000 W (remote)

- ① Cover, electronics compartment
- ② Cover for the three separate terminal compartments for power, sensor connection and inputs/outputs
- ③ Locking screw, 1/2 turn left/right to open/close cover ②
- ④ Sensor terminal compartment
- ⑤ Terminal compartment for inputs/outputs
- ⑥ Power terminal compartment, open separate shock-hazard protection cover

4.3 Electrical connection

- The VersaFlow Sonic 1000 flow sensor is connected to the TWS 9000 signal converter via a single signal cable.
- Proper functioning is ensured when using this factory supplied signal cable.

4.3.1 Signal cable to flow sensor

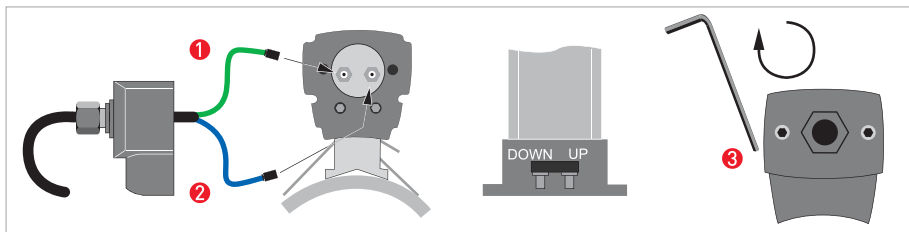


Figure 4-4: Connecting the signal cable to the rail (small and medium version)

- 1 Connect the green cable to "DOWN"
- 2 Connect the blue cable to "UP"
- 3 Turn the screws clockwise to secure the cap

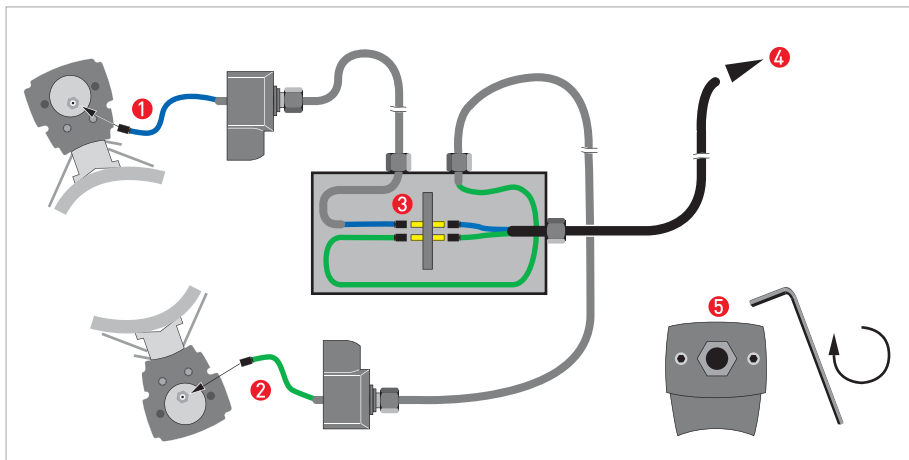


Figure 4-5: Connections in cable box (large version)

- 1 Connect the blue cable to the UP rail.
- 2 Connect the green cable to the DOWN rail.
- 3 Make connections in cable box.
- 4 Cable to converter
- 5 Turn the screws clockwise to secure the caps.

4.3.2 Signal cable and power supply signal converter



NOTE!

The power terminals in the terminal compartments are equipped with additional hinged lids to prevent accidental contact.



DANGER!

Signal converter must be properly grounded to avoid personnel shock hazard.

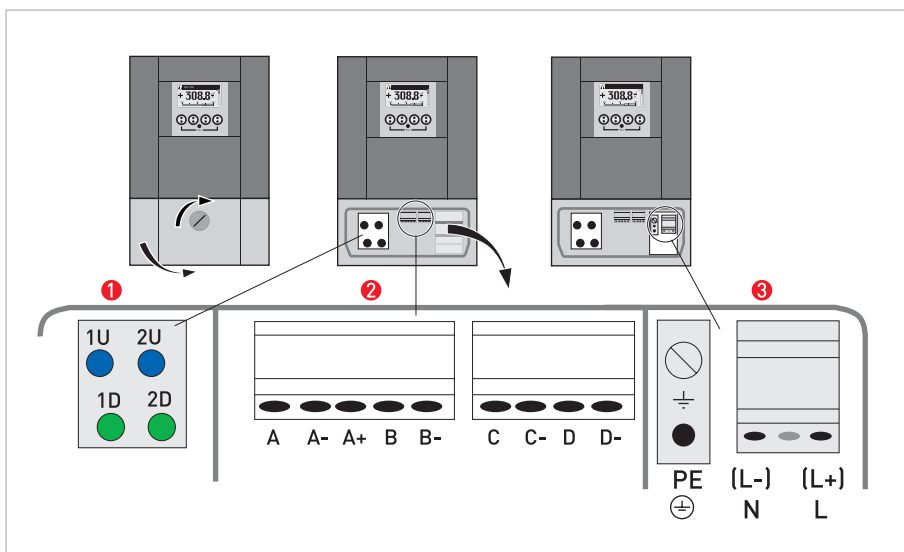


Figure 4-6: Construction of TWS 9000 W (wall)

- ① Connect blue cable to 1U (to 2U for 2nd sensor) and the green cable to 1D (2D for 2nd sensor)
- ② Communication I/O
- ③ Power supply: 24 VAC/DC or 100...240 VAC

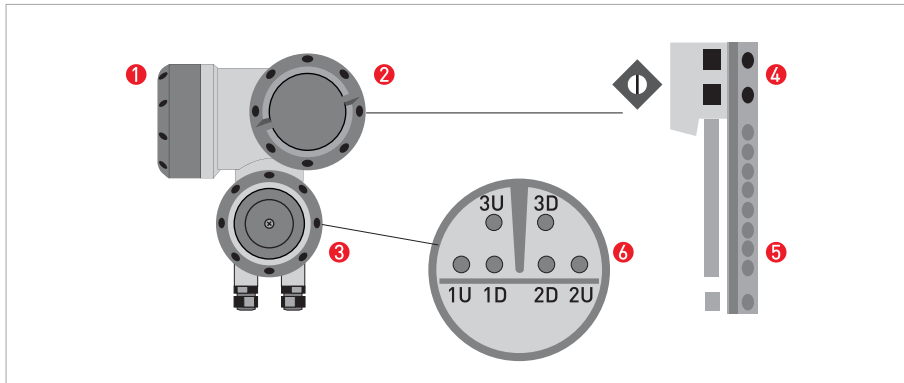


Figure 4-7: Construction of TWS 9000 F (field)

- ❶ Cover, electronics compartment
- ❷ Cover, terminal compartment for power supply and inputs/outputs
- ❸ Cover, sensor terminal compartment
- ❹ Cable entry for power
- ❺ Cable entry for inputs/outputs
- ❻ Cable entry for sensor cable

100...230 VAC (-15% / +10%)

- Connect the protective ground conductor PE of the mains power supply to the separate terminal in the terminal compartment of the signal converter.
- Connect the live conductor to the L terminal and the neutral conductor to the N terminal.

24 VAC/DC (-15% / +10%)

- For reasons to do with the measurement process, connect a functional ground FE to the separate U-clamp terminal in the terminal compartment of the signal converter.
- When connecting to functional extra-low voltages, provide a facility for protective separation (PELV) (VDE 0100 / VDE 0106 and/or IEC 364 / IEC 536 or relevant national regulations).

4.4 Basic inputs and outputs

The VersaFlow Sonic 1000 with TWS 9000 has several in / output ports, accessible via the terminal compartment of the TWS 9000 signal converter for interfacing with external devices. The terminal compartment is accessible after unscrewing cover.



Figure 4-8: TWS 9000 F, I/O terminals

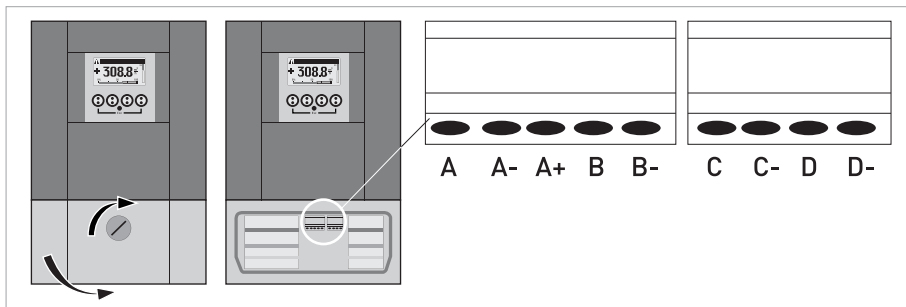


Figure 4-9: TWS 9000 W, I/O terminals

The input / output ports are galvanic separated from each other and from all other input and output circuits.

- **Active I/O:** the TWS 9000 signal converter supplies the power for operation
- **Passive I/O:** an external power supply is required

Basic I/O consisting of:

- 1 current output,
- 1 pulse output,
- 1 status output,
- 1 control input.

The pulse output can also be set as a status output. One of the status outputs can be set as a control input.

**INFORMATION!**

For detailed information please also refer to Modular Inputs and Outputs on page 44.

4.4.1 General

- Depending on the version, the inputs and outputs to be connected passively or actively and / or to NAMUR EN 60947-5-6.
- All inputs and outputs are galvanic separated from each other and from all other circuits.
- Factory-set data and functions are mentioned in the delivered factory calibration certificate.
- All operating data and functions are adjustable (see menu structure).

**WARNING!**

All directions, operating data and connection diagrams do not apply to devices used in hazardous areas.

**CAUTION!**

The following connection diagrams and operating data do not apply to hazardous-duty equipment (EEx).

**NOTE!**

Terminals that are not used should not have any conductive connection to other electrically conductive parts.

4.4.2 Electrical symbol description


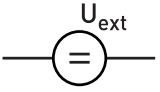
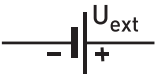

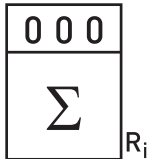

	mA meter
	External voltage source
	Current voltage source, in-house
	Steered current generator, in-house
	Electronic totalizer
	Push-button

Table 4-1: Symbol description

4.4.3 Current output (analog)

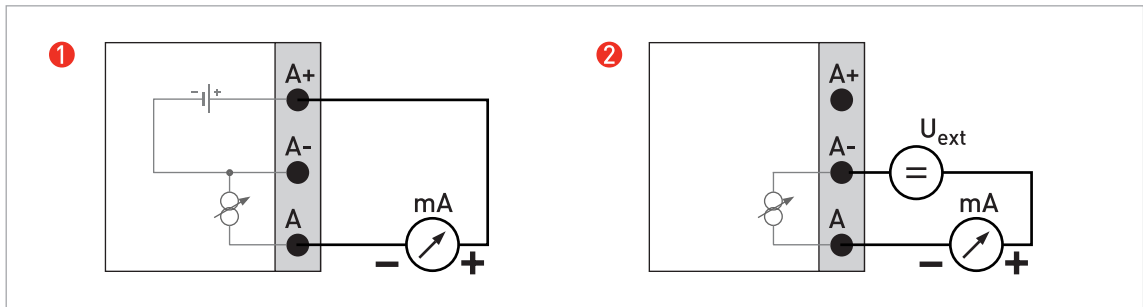


Figure 4-10: Connection current output

- ❶ **Active mode:** load impedance $R_l \leq 1 \text{ k}\Omega$ at $I \leq 22 \text{ mA}$
- ❷ **Passive mode:** external power supply; $U_{\text{ext}} \leq 32 \text{ VDC}$ at $I \leq 22 \text{ mA}$

4.4.4 Pulse output (digital)

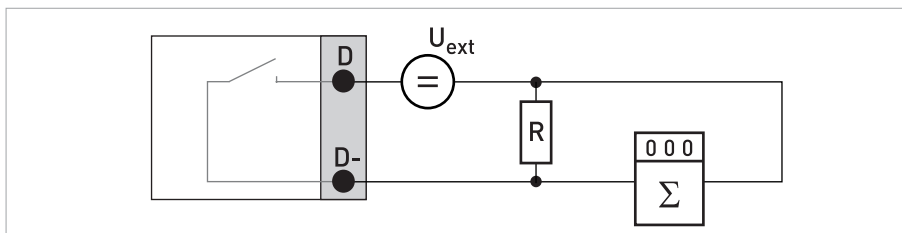
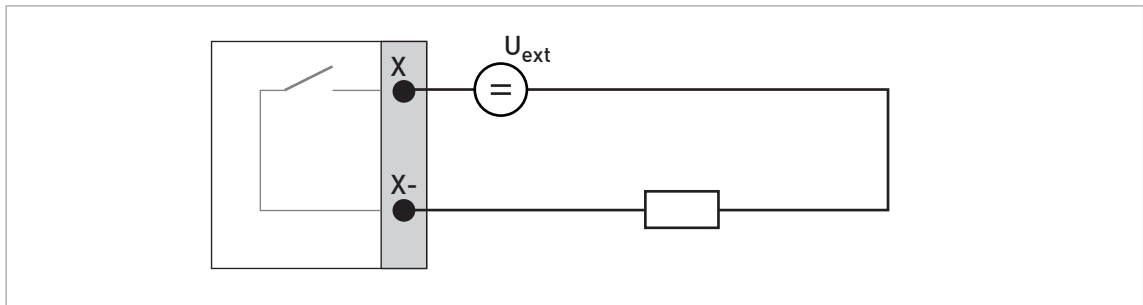


Figure 4-11: Connection pulse output passive (P_p)

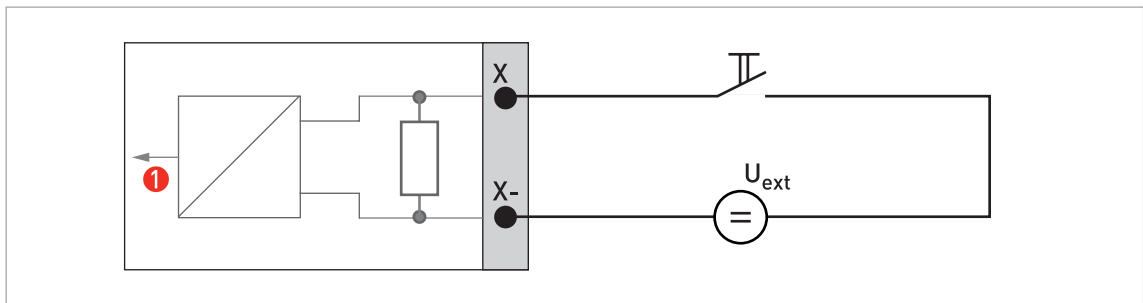
- $R = 1.2 \text{ k}\Omega / 0.5 \text{ W}$, only necessary when using electronic totalizer
- Electronic totalizer with internal resistance of more than $5 \text{ k}\Omega$
- **Passive mode:**
external power supply; $U_{\text{ext}} \leq 32 \text{ VDC}$ at $I \leq 20 \text{ mA}$ and $\text{freq} \leq 10 \text{ kHz}$
- **Active mode:**
internal power supply; $U_{\text{nom}} \leq 24 \text{ VDC}$ at $I \leq 20 \text{ mA}$ and $\text{freq} \leq 10 \text{ kHz}$
- **NAMUR mode:**
passive in accordance with EN 60947-5-6

4.4.5 Status output (digital)

Figure 4-12: Connection status output passive (S_p); (X = terminals B or D)

- **Passive mode:**
external power supply; $U_{ext} \leq 32$ VDC at $I \leq 100$ mA and $freq \leq 10$ kHz
- **Active mode:**
internal power supply; $U_{nom} \leq 24$ VDC at $I \leq 100$ mA and $freq \leq 10$ kHz
- **NAMUR mode:**
passive in accordance with EN 60947-5-6

4.4.6 Control input (digital)

Figure 4-13: Connection control input passive (C_p)

① Signal

- $U_{ext} \leq 32$ V DC
- I_o 16 mA at 24 V
- $I \leq 20$ mA
- $U_{on} > 19$ VDC
- $U_{off} < 2.5$ VDC

4.4.7 Connection via HART®



NOTE!

In the Basic I/O, the current output at terminals A+ / A- / A is always HART®-compatible!

In the Modular I/O, only the current output module for terminals C / C- is HART®-compatible!

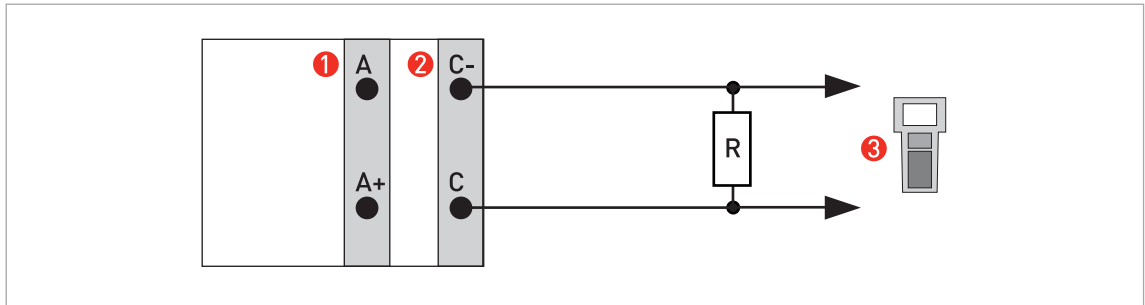


Figure 4-14: HART® connection active (I_a)

- ❶ Basic I/O terminal A and A+
- ❷ Modular I/O terminal C and C-
- ❸ HART® communicator

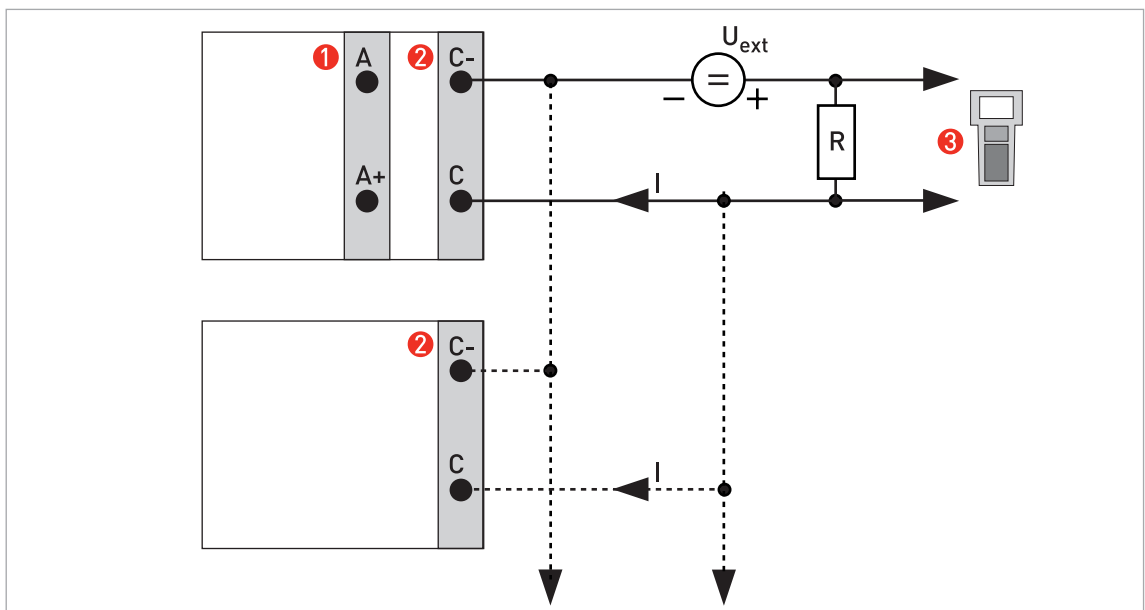


Figure 4-15: HART® connection passive (I_p)

- ❶ Basic I/O terminal A and A-
- ❷ Modular I/O terminal C and C-
- ❸ HART® communicator

$I: I_{0\%} = 4 \text{ mA};$

Multidrop I: $I_{\text{fix}} = 4 \text{ mA};$

$U_{\text{ext}} \leq 32 \text{ VDC}; R \geq 230 \Omega$

4.5 Modular Inputs and Outputs



INFORMATION!

In the following connection diagrams, the terminals A, B, C or D (depending on the version of the TWS 9000) are marked with a "X".

4.5.1 Alterable I/Os

CG-No.	Terminals								
	D-	D	C-	C	B-	B	A-	A	A+
4		P_a / S_a ①		$I_a + \text{HART}^{\text{®}}$ active		max. 2 option modules for terminals B + A: I_a or P_a / S_a or C_a			
8		P_a / S_a ①		$I_p + \text{HART}^{\text{®}}$ passive		max. 2 option modules for terminals B + A: I_p or P_a / S_a or C_a			
6		P_p / S_p ①		$I_a + \text{HART}^{\text{®}}$ active		max. 2 option modules for terminals B + A: I_a or P_p / S_p or C_p			
B		P_p / S_p ①		$I_p + \text{HART}^{\text{®}}$ passive		max. 2 option modules for terminals B + A: I_p or P_p / S_p or C_p			
7		P_N / S_N NAMUR ①		$I_a + \text{HART}^{\text{®}}$ active		max. 2 option modules for terminals B + A: I_a or P_N / S_N or C_N			
C		P_N / S_N NAMUR ①		$I_p + \text{HART}^{\text{®}}$ passive		max. 2 option modules for terminals B + A: I_p or P_N / S_N or C_N			

① changeable

Option modules

Abbreviation	Description	Ident. for CG No.
I_a	Active current output	A
I_p	Passive current output	B
P_a / S_a	Active pulse, frequency, status output or limit switch	C
P_p / S_p	Passive pulse, frequency, status output or limit switch	E
P_N / S_N	Pulse, frequency, status output or limit switch to NAMUR	F
C_a	Active control input	G
C_p	Passive control input	K
C_N	Control input to NAMUR	H
-	No module installed	8
-	No further module possible	0

4.5.2 Current output active I_a (HART[®])

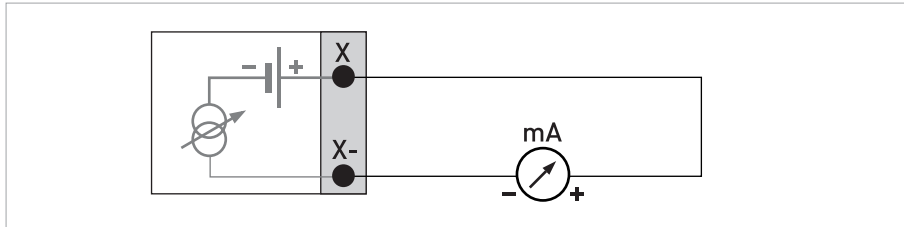


Figure 4-16: Current output active I_a

- $U_{int} = 24 \text{ VDC}$
- $I \leq 22 \text{ mA}$
- $R_L \leq 1 \text{ k}\Omega$

4.5.3 Current output passive I_p (HART[®])

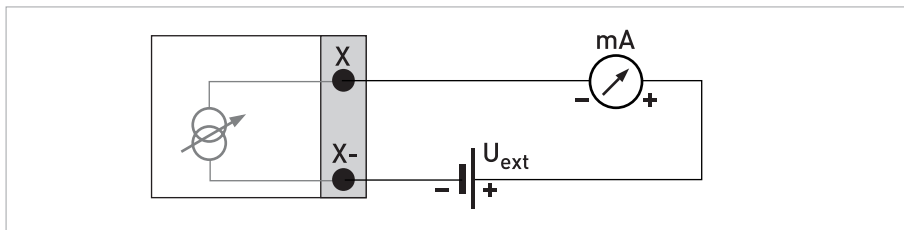
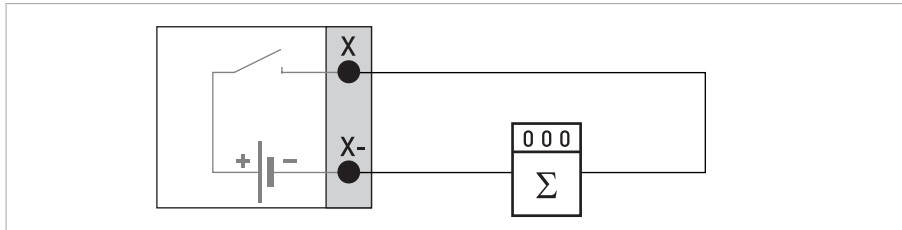
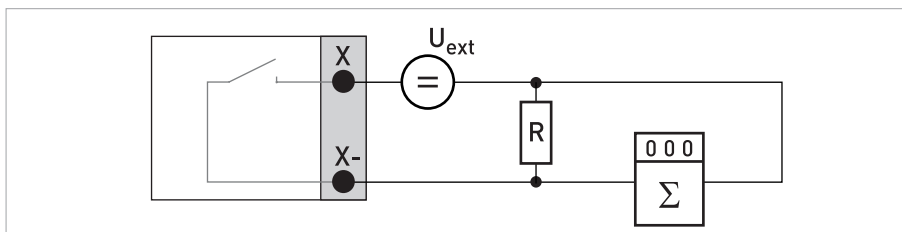


Figure 4-17: Current output passive I_p

- $I \leq 22 \text{ mA}$
- $U_{ext} \leq 32 \text{ VDC}$

4.5.4 Pulse / frequency output active P_a Figure 4-18: Pulse / frequency output active P_a

- $U_{ext} = 24 \text{ VDC}$
- $f \leq 10 \text{ kHz}: I \leq 20 \text{ mA}$
- $f \leq 100 \text{ kHz}: I \leq 100 \text{ mA}$
- $U_0 = 1.5 \text{ V}$ at 10 mA
- $U_{nom} = 24 \text{ VDC}$

4.5.5 Pulse / frequency output passive P_p Figure 4-19: Pulse / frequency output passive P_p

- $U_{ext} = 32 \text{ VDC}$
- $f \leq 10 \text{ kHz}: I \leq 20 \text{ mA}$
- $f \leq 100 \text{ kHz}: I \leq 100 \text{ mA}$
- $U_0 = 1.5 \text{ V}$ at 10 mA
- $R = 1.2 \text{ k}\Omega / 0.5 \text{ W}$ (only necessary when using electronic totalizer with internal resistance of $R_i > 5 \text{ k}\Omega$)

4.5.6 Status output / limit switch active S_a

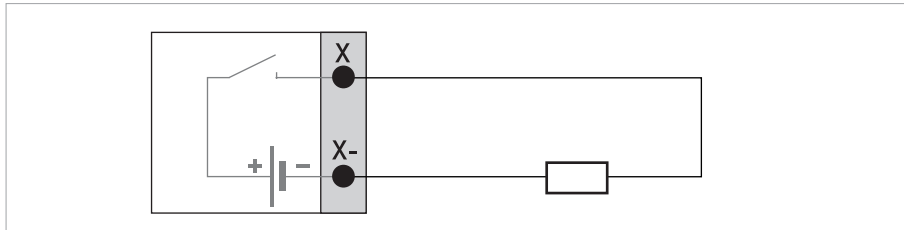


Figure 4-20: Status output / limit switch active S_a

- $U_0 = 1.5 \text{ V}$ at 10 mA
- $I \leq 100 \text{ mA}$
- $U_{\text{nom}} = 24 \text{ VDC}$

4.5.7 Status output / limit switch passive S_p

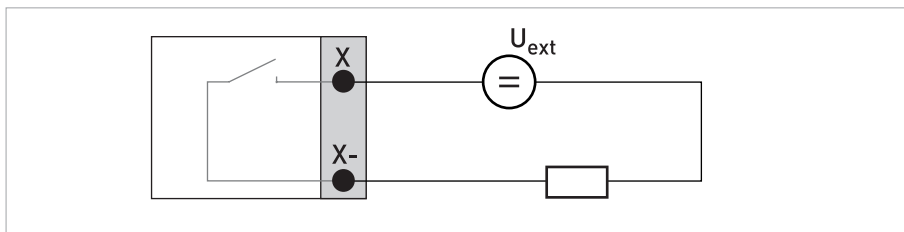


Figure 4-21: Status output / limit switch passive S_p

- $U_0 = 1.5 \text{ V}$ at 10 mA
- $U_{\text{ext}} = 32 \text{ VDC}$
- $I \leq 100 \text{ mA}$

4.5.8 Control input active C_a

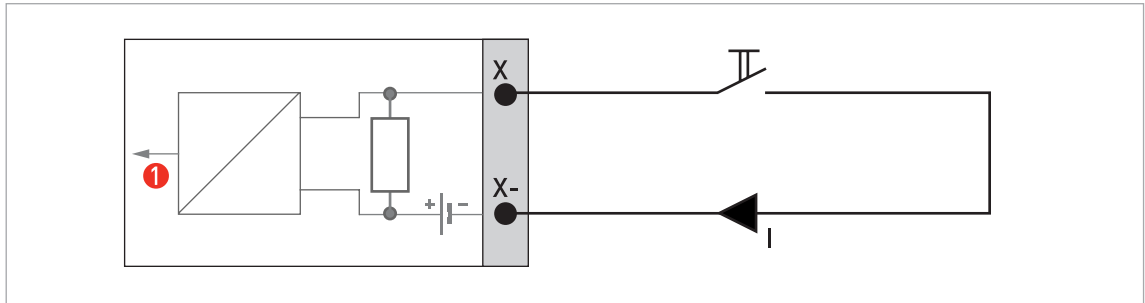


Figure 4-22: Control input active C_a

① Signal

- $I_{nom} = 16 \text{ mA}$
- $U_{nom} = 24 \text{ VDC}$

4.5.9 Control input passive C_p

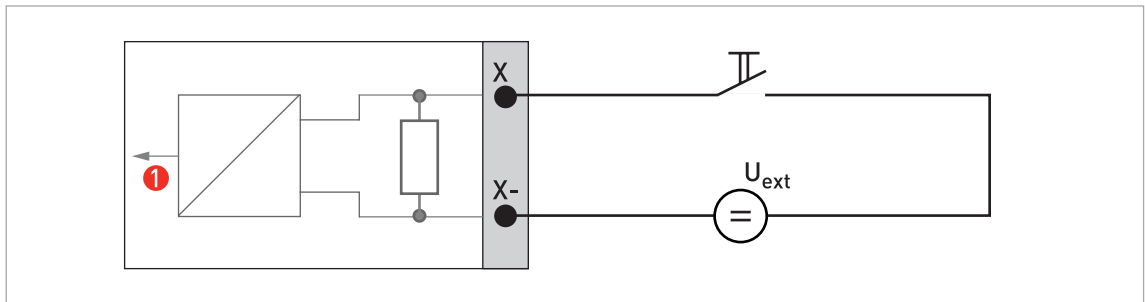


Figure 4-23: Control input passive C_p

① Signal

- $U_{on} > 19 \text{ VDC}$
- $U_{off} < 2.5 \text{ VDC}$
- $U_{ext} \leq 32 \text{ VDC}$
- $U_{nom} = 16 \text{ mA}$

4.5.10 Connection via HART®



NOTE!

In the Basic I/O, the current output at terminals A+ / A- / A is always HART®-compatible!

In the Modular I/O, only the current output module for terminals C / C- is HART®-compatible!

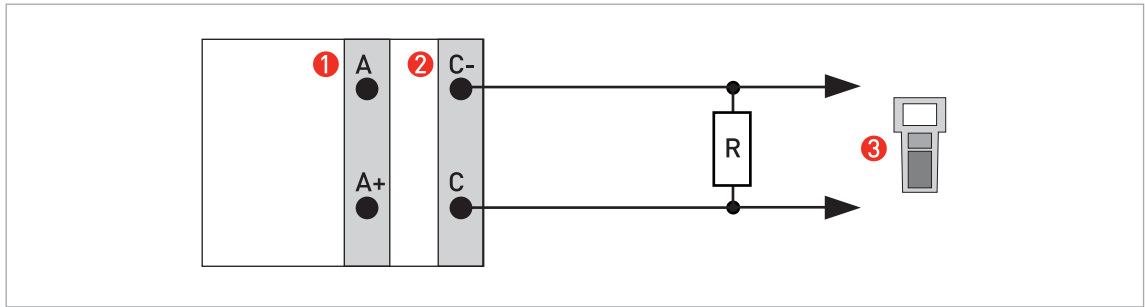


Figure 4-24: HART® connection active (I_a)

- ❶ Basic I/O terminal A and A+
- ❷ Modular I/O terminal C and C-
- ❸ HART® communicator

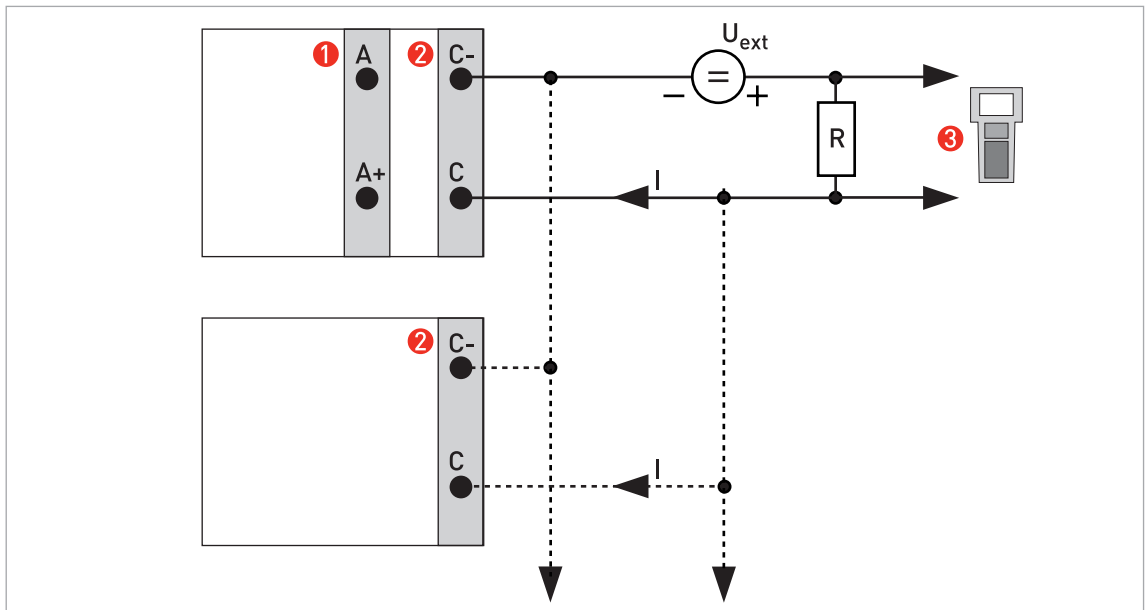


Figure 4-25: HART® connection passive (I_p)

- ❶ Basic I/O terminal A and A-
- ❷ Modular I/O terminal C and C-
- ❸ HART® communicator

I: $I_{0\%} = 4 \text{ mA}$;

Multidrop I: $I_{fix} = 4 \text{ mA}$;

U_{ext} $\leq 32 \text{ VDC}$; $R \geq 230 \Omega$

4.5.11 Pulse, frequency and status output / limit switch passive P_N / S_N to NAMUR EN 60947-5-6

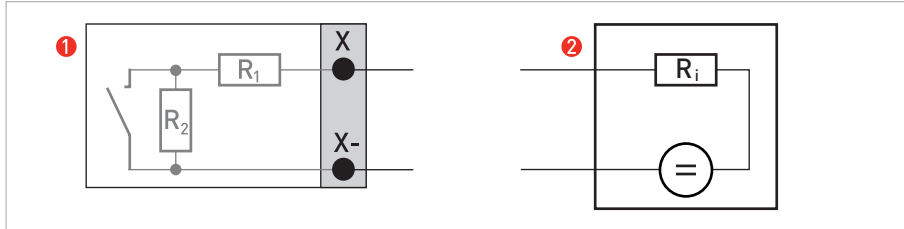


Figure 4-26: Pulse, frequency and status output / limit switch passive P_N / S_N to NAMUR EN 60947-5-6

- ① Switching amplifier to NAMUR with internal voltage source
- ② $R_i = 1\text{ k}\Omega$; $U = 8.2\text{ VDC}$

4.5.12 Control input active C_N to NAMUR EN 60947-5-6

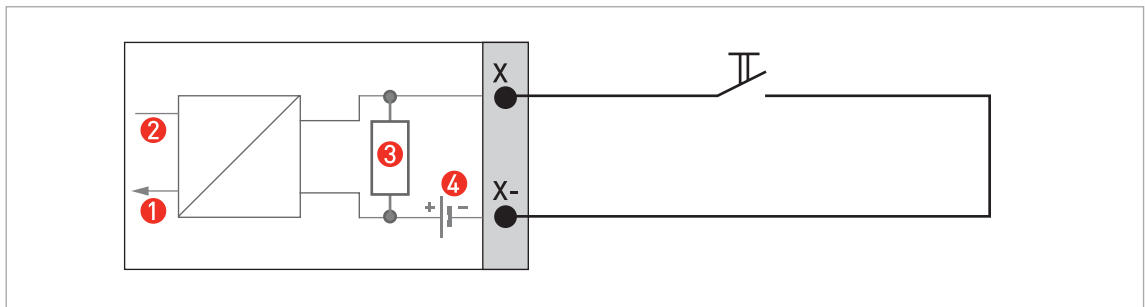


Figure 4-27: Control input active C_N to NAMUR EN 60947-5-6

- ① Signal
- ② Error
- ③ $R_i = 1\text{ k}\Omega$
- ④ $U = 8.2\text{ VDC}$



DANGER!

Before connecting the TWS 9000 signal converter to power, check if the power supply is corresponding with the VersaFlow Sonic 1000 with TWS 9000 clamp-on flowmeter.

5.1 General instructions for programming

Human machine interface (HMI)

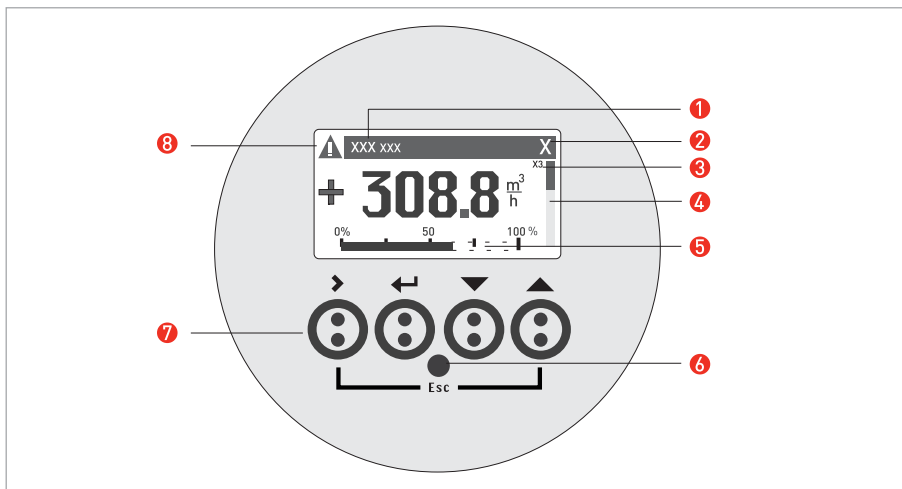


Figure 5-1: Display and operating elements

- 1 Product name
- 2 X shows optical button is activated
- 3 Indication of menu number
- 4 Block indicates the menu level
- 5 0...100%
- 6 Infrared sensor
- 7 Operating keys (see table below for description)
- 8 ↑↓: scroll

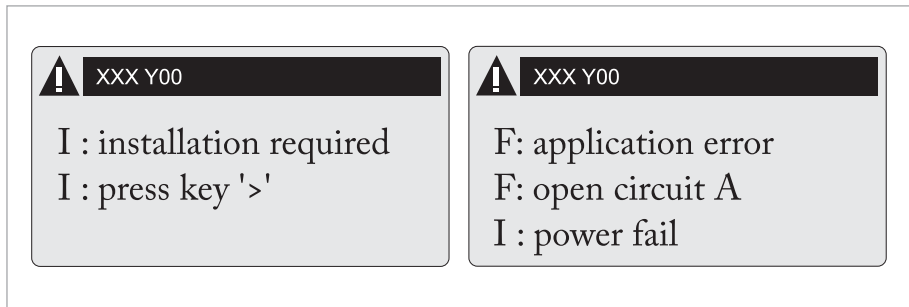
Key	Description	Used symbol
	start installation, select menu	>
	return	←
	down	↓
	up	↑
	escape	> + ↑

Table 5-1: Key functions

Start installation menu



- Connect converter to power supply and power up converter.



First and second page appear intermittently



- Keep left button ">" pressed, until in display appears "release key now".

Installation menu



• > ↓ ↑ ←

X1...X7

X1	language	>	select from list using ↑ ↓ >		←
X2	GDC IR interface	>	activate / cancel		←
X3	units	>	X3.1, X3.2, ...	↑ ↓	
	X3.1 size	>	select from list using ↑ ↓ >		←
	X3.2 volume flow	>	select from list using ↑ ↓ >		←
	X3.3 velocity	>	select from list using ↑ ↓ >		←
	X3.4 density	>	select from list using ↑ ↓ >		←
	X3.5 viscosity	>	select from list using ↑ ↓ >		←
X4	number of pipes	>	1 pipe / 2 pipes	↑ ↓	←
[X5 becomes active if one pipe is selected in X4]					
X5	number of paths	>	1 path / 2 paths	↑ ↓	←
[underneath X6 becomes active if one pipe is selected in X4]					
[Note: the measurement results of path 1 and path 2 are averaged !]					
[underneath X6 and X7 become active if two pipes are selected in X4]					
X6	pipe data / pipe data 1	>	X6.2, X6.3, ...	↑ ↓	
	X6.2 pipe tag	>	fill in 12 pos using ↑ ↓ >		←
	X6.3 diameter	>	fill in using ↑ ↓ >		←
	X6.4 pipe material	>	select from list using ↑ ↓ >		←
	X6.5 VoS pipe material	>	read advise or fill in using ↑ ↓ >		←
	X6.6 wall thickness	>	fill in using ↑ ↓ >		←
	X6.7 liner material	>	select from list using ↑ ↓ >		←
	X6.8 VoS liner material	>	read advise or fill in using ↑ ↓ >		←
	X6.9 liner thickness	>	fill in using ↑ ↓ >		←
	X6.1 0 fluid	>	select from list using ↑ ↓ >		←
	X6.1 1 VoS fluid	>	read advise or fill in using ↑ ↓ >		←
	X6.1 2 density	>	read advise or fill in using ↑ ↓ >		←
	X6.1 3 viscosity	>	fill in using ↑ ↓ >		←
X7	pipe data 2	>		↑ ↓	
	X7.1 copy pipe 1 data	>	start to copy ?	↑ ↓	

			if no:	copy pipe 1 data appears Go to X7 Fill in menu X7.2 up to X7.13: is similar to X6.2 up to X6.13	←
			if yes:	copy pipe 1 data appears after copy process	←

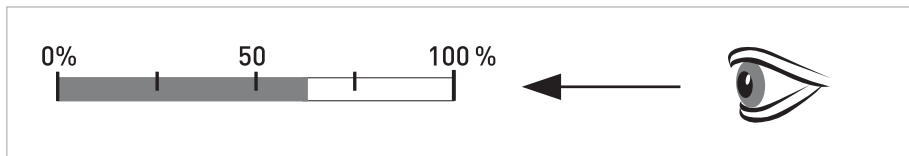
X9...X10

X9	install transd. 1	>	X9.1, X9.2,...	↑ ↓	
	X9.1	transducer set	>	read preset Ta,Tb,Tc / confirm or overrule using ↑ ↓ >	
	X9.2	calibration number		read	←
	X9.3	number of traverses	>	read preset 1,2,4 / confirm or overrule using ↑ ↓ >	
	X9.4	mount transducers at		read advise	←
	please wait: decounting 30 seconds				
	X9.5	act. flow, preliminary		read	←
	X9.6	check signal		read (0 - 100 %)	←
	X9.7	actual distance	>	fill in using ↑ ↓ >	←
	[start optimization loop]				
	X9.8.1	optimize distance ?		yes/no	←
				if no:	go to X9.9
				if yes:	continue with X9.8.2
	X9.8.2	act. VoS fluid		read	←
	X9.8.3	continue ?		yes/no	←
				if no:	go to X9.9
				if yes:	continue with X9.8.4
	X9.8.4	VoS fluid		read / confirm or overrule using ↑ ↓ >	←
	X9.8.5	mount transducers at		read advise	←
	[end optimization loop; next menu appearing is X9.8.1]				
	(underneath X10 becomes active if two pipes or two paths are selected in X4 or X5)				
X10	install transd. 2	>		↑ ↓	
				submenus identical to X9.1 up to X9.12	
					←

5.2 Start measurement of small / medium version



- Power up the converter (do not mount and/or connect the rails yet)
- Fill in menu X1...X7 (see section "Installation menu" in chapter "General instructions for programming")
- X9.1: Check the reading with the sensor code (Ta/Tb) on rail. Press enter
- X9.2: Check the reading with the calibration number on the nameplate. Press enter
- X9.3: Check the factory preset number of traverses (default: 2, for DN<25: 4)
- X9.4: Read the advised mounting distance and position the transducer at that distance . Press enter
- X9.5: Read the preliminary volume flow. Press enter
- X9.6: Read the actual signal strength



INFORMATION!

Advice on signal strength:

Signal > 75%: good signal, optimization loop not needed

Signal 50...75%: fairly good signal, optimization loop can improve the signal

Signal 10...50%: low signal, optimization loop needed

Signal < 10%: bad or no signal, check settings in menu X6, increase transducer distance and/or go into the optimization loop.



- X9.7: Confirm or adjust the reading with the actual distance on the rail.
- X9.8: Optimization loop. Repeat steps X9.8.1...X9.8.5 until the advised mounting distance does not change more than 0.5%.
 - X9.8.1: Optimise distance?
 - X9.8.2: Read the velocity of sound of the fluid
 - X9.8.3: Continue?
 - X9.8.4: Confirm or adjust the velocity of sound
 - X9.8.5: Read the advised mounting distance and reposition the transducer
- X9.9: Read the preliminary volume flow
- X9.10: Path ready? If you enter "No" then the installation is not saved. If you enter "Yes" the installation can be saved in X9.11. If you have:
 - 1 path or pipe: you are finished, proceed with X9.12
 - 2 paths or pipes: go to X10 for the 2nd sensor
- X9.12: End Installation? If you enter "No" the installation is not saved, go to X9. If you enter "Yes" the installation is saved and the measurement screen will appear.
- Mount the cover (see the section "mounting the cover" in chapter "General mechanical installation")

5.3 Start measurement of large version

Prepare installation

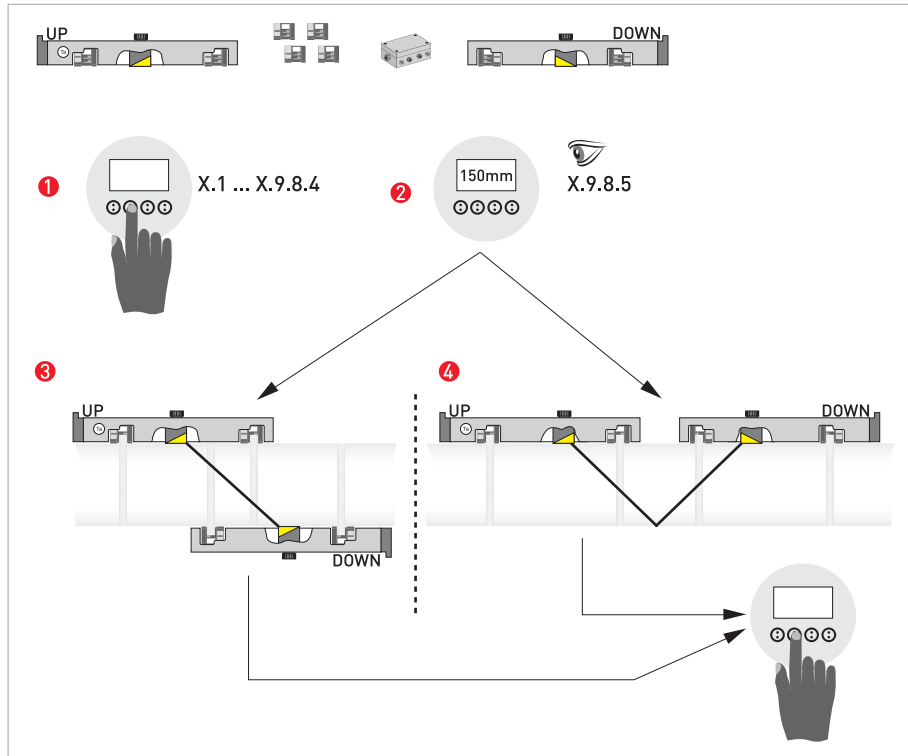


Figure 5-2: Procedure for installation of large version

- 1 Enter the values for the installation menu, X1...X9.8.4
- 2 Read the advised mounting distance in menu X9.8.5
- 3 Choose for Z-mode (default) or ...
- 4 Choose for V-mode
- 5 Finish the installation menu



- Power up the converter (do not mount and/or connect the rails yet)
- Fill in menu X1...X7 as described in section "Installation menu" in chapter "General instructions for programming". Select "1 path" initially in X5
- X9.1: Check the reading with the sensor code (Ta/Tb) on rail
- X9.2: Check the reading with the calibration number on the nameplate
- X9.3: Check the factory preset number of traverses (default: 1 for Z-mode)
- X9.4: Read the advised mounting distance. Write it down, you need it later
- X9.5: Press enter
- X9.6: Press enter. Wait for 30 seconds
- X9.7: Press enter
- X9.8: Optimization loop. Enter "No" in X9.8.1
- X9.9: Press enter. Wait for 30 seconds

- X9.10: Path ready? Enter "Yes"
- X9.12: End Installation? Enter "Yes"



CAUTION!

Choose between Z and V mode before you proceed. The Advised Distance (menu X9.4) must be > 246 mm / 9,7" for V-mode.

Set transducer positions for both rails according to the table below.

Advised distance [mm]	Transducer position [mm]
100...250	-65
>250	0

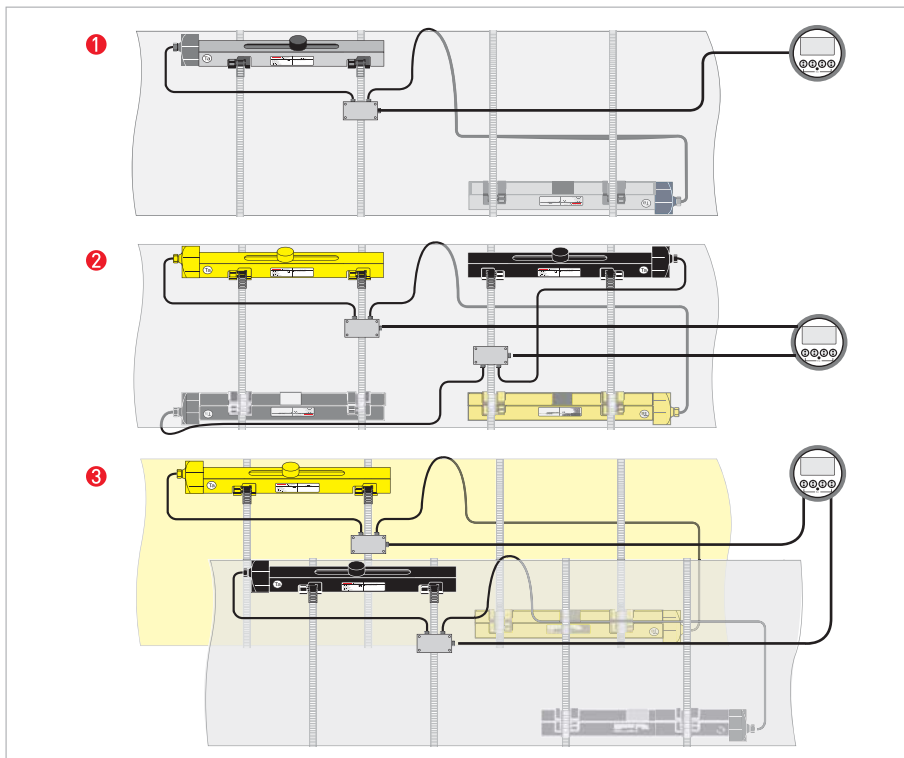


Figure 5-3: Instrument versions

- ① Single pipe, single path
- ② Single pipe, dual path
- ③ Dual pipe

5.4 Mechanical installation for large version



INFORMATION!

You need a calculator, measuring band and pen & paper to install a large version.

Mounting the UP rail



CAUTION!

Make sure that you mount the rail parallel to the pipe. Mount the fixing units and the cable box as shown below.

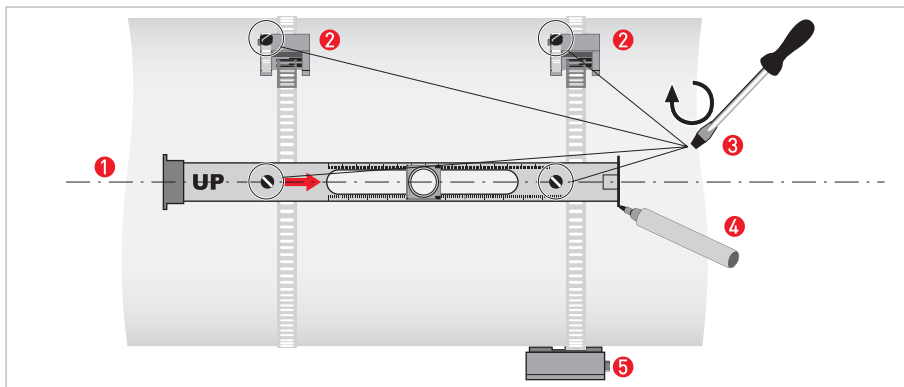


Figure 5-4: Mounting the large rail

- ① Align the UP rail with the pipeline.
- ② Fixing units
- ③ Turn screws clockwise to secure.
- ④ Mark the position.
- ⑤ Cable box

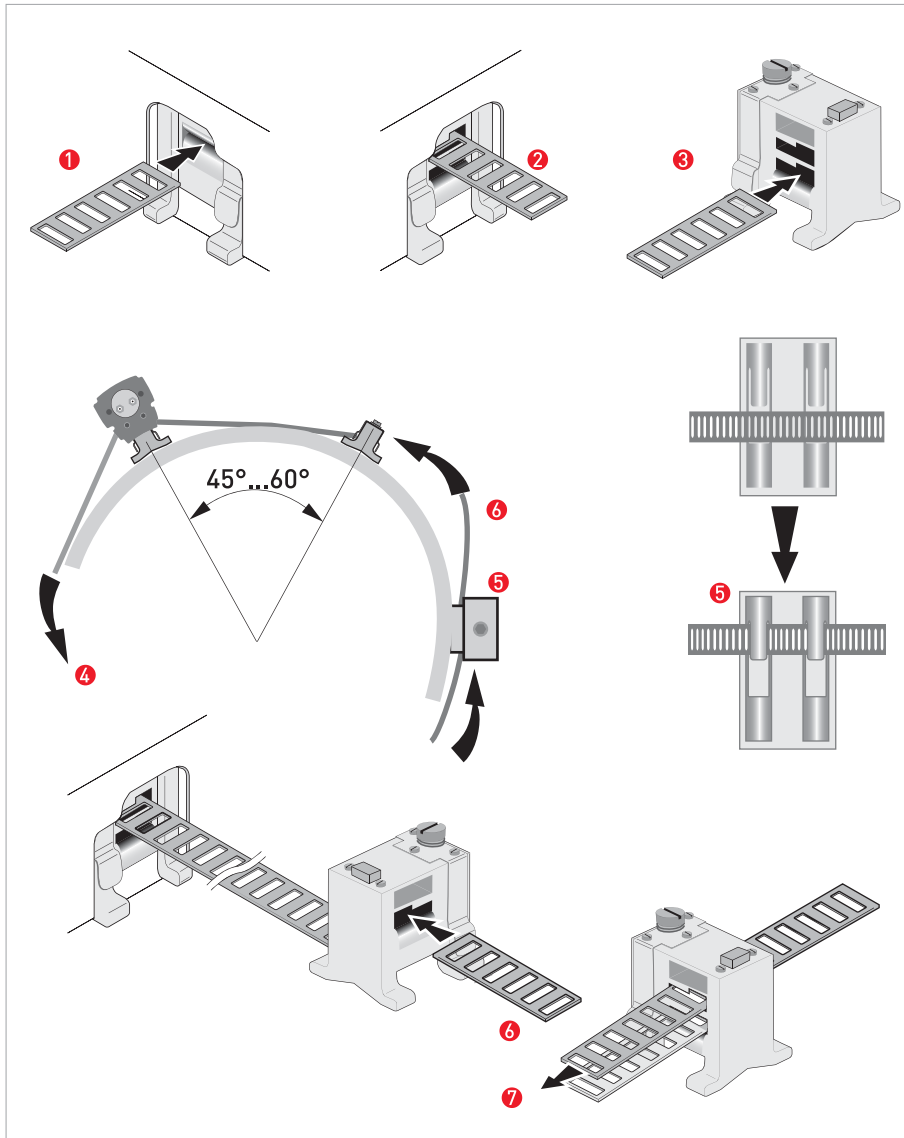


Figure 5-5: Mounting large version rail

- 1 Pull the metal strap through the upper slit of the UP rail.
- 2 Take the metal strap around the pipe (45...60°).
- 3 Push the end of the metal strap in the lower slit of the fixing unit.
- 4 Take the other side of the metal strap around the pipe to the fixing unit.
- 5 Mount the cable box (only for downstream metal strap).
- 6 Push the metal strap through the upper slit of the fixing unit.
- 7 Pull the metal strap moderately tight by hand.



- Secure by turning screws clockwise.

Mounting the DOWN rail in Z-mode

Set transducer positions for both rails according to the table below.

Advised distance [mm]	Transducer position [mm]
100...250	-65
>250	0

Measure the outer diameter of the pipe with a measuring band.
 For Z-mode, you must install the DOWN rail at the opposite location at the pipe. There are two possible ways to find the exact location:

1. FIND THE LOCATION WITH A FIXED REFERENCE POINT

Calculate the half of the outer diameter. Mark this 180° alignment line on the pipe.

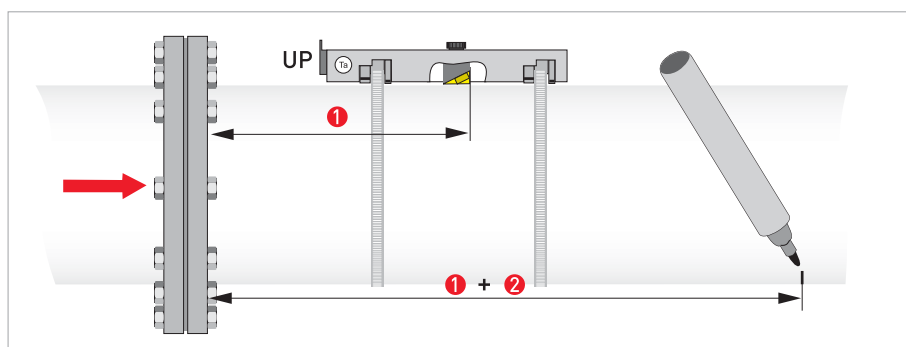
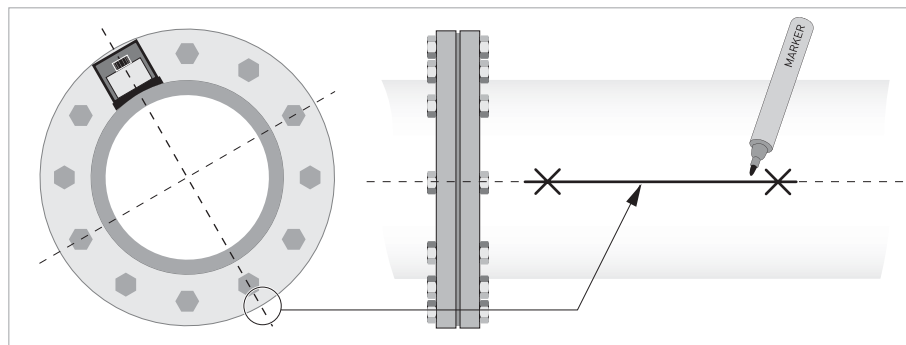


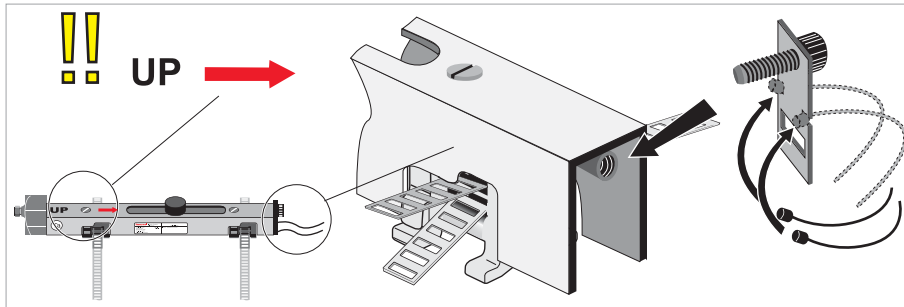
Figure 5-6: Find the opposite location with a reference point

- ① Measure the distance between the transducer of the UP rail and the reference point.
- ② Add the Advised Distance and mark the location on the alignment line.

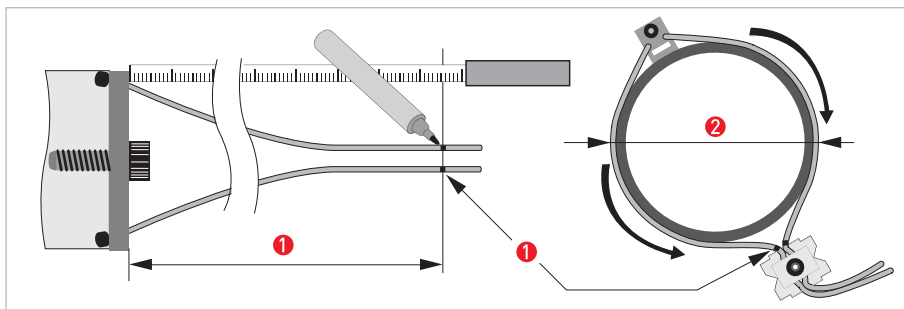


- Mount the DOWN rail in such a way that the transducer is at the marked location.

2. FIND THE LOCATION WITH THE SUPPLIED POSITIONING TOOL



- Mount the positioning tool to the UP rail as shown.



- ① Mark the cables at a distance of 1.63 x outer diameter.
- ② Outer diameter of pipeline



INFORMATION!

For large diameters you can use the weight of the metal plates to throw the cable around the pipe. First release one of the cables in that case!

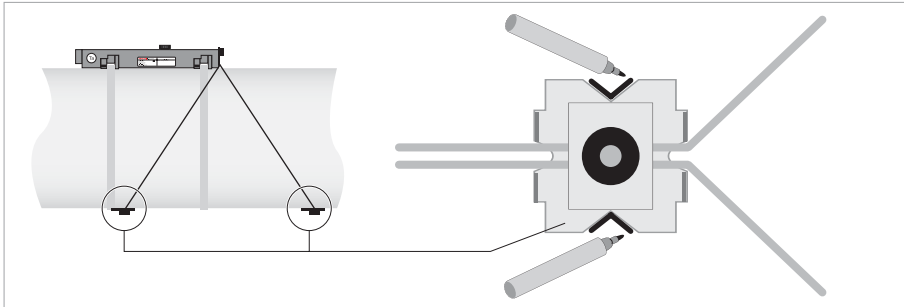


Figure 5-7: Mark the pipelines with the V-mark

- Pull the V-shaped plate in the downstream direction as much as possible. Pay attention that the cables are not obstructed. Put the two V-marks on the pipeline.
- Do the same in the upstream direction.



CAUTION!

Repeat above steps to check if you find the same points.

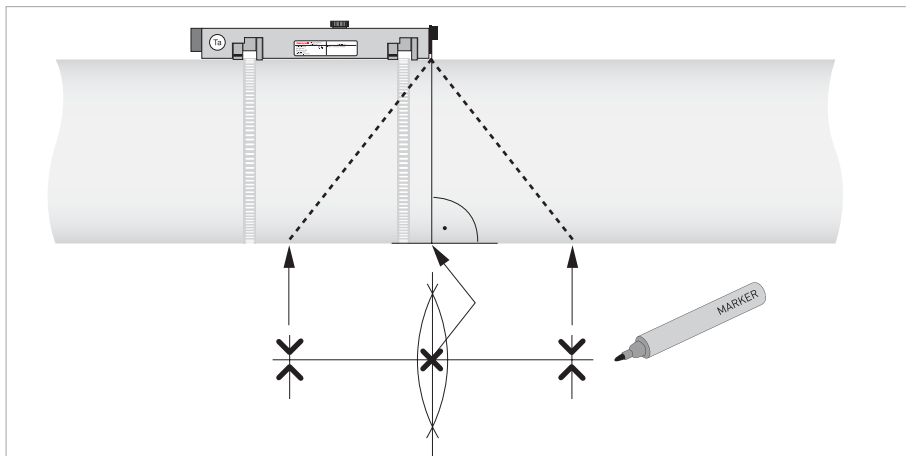


Figure 5-8: Marking the opposite location

- Calculate the middle of the alignment line between the 4 V-marks as shown.

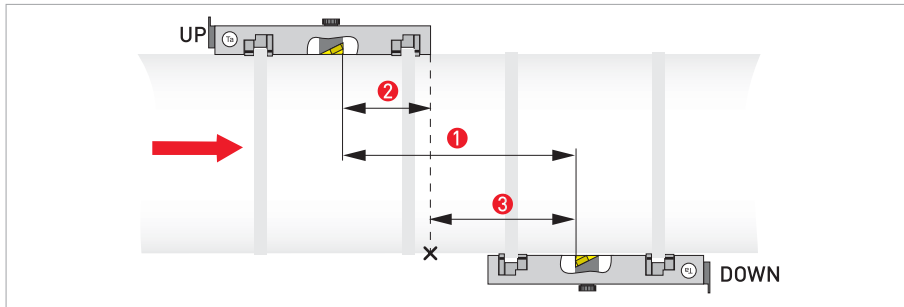


Figure 5-9: Finding the location for the DOWN rail

- ① Advised Distance as shown in menu X9.4
- ② Measure the distance between the transducer and the end of the UP rail.
- ③ Determine and mark the location of the transducer of the DOWN rail: $③ = ① - ②$

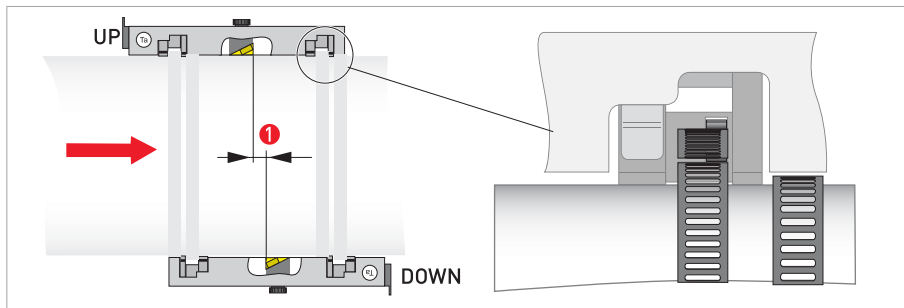


- Mount the DOWN rail in such a way that the transducer is at the marked location.
- Grease all transducers, see "General mechanical installation".



INFORMATION!

It can be necessary to install the DOWN rail as shown below.



Mounting the DOWN rail in V-mode

For V-mode, you must install the DOWN rail in line with the UP rail. It is easier to install than the Z-mode, but you need more free pipe length. V-mode is possible for DN450/600...2000 (minimum depends on application).

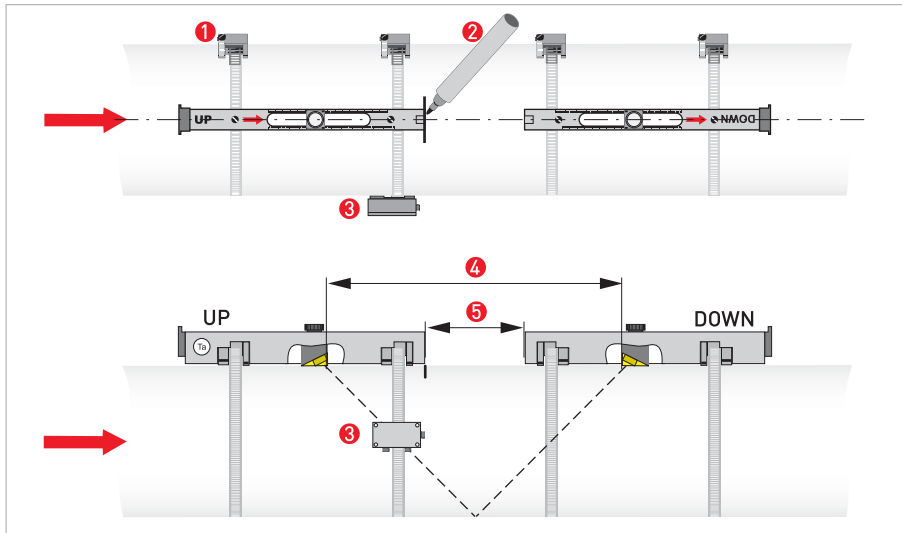


Figure 5-10: Mounting large version in V-mode

- ① Fixing units
- ② Reference marking
- ③ Cable box
- ④ Advised Distance, X9.4
- ⑤ Minimum distance between UP and DOWN rail: 110 mm / 4.3"

Electrical connections

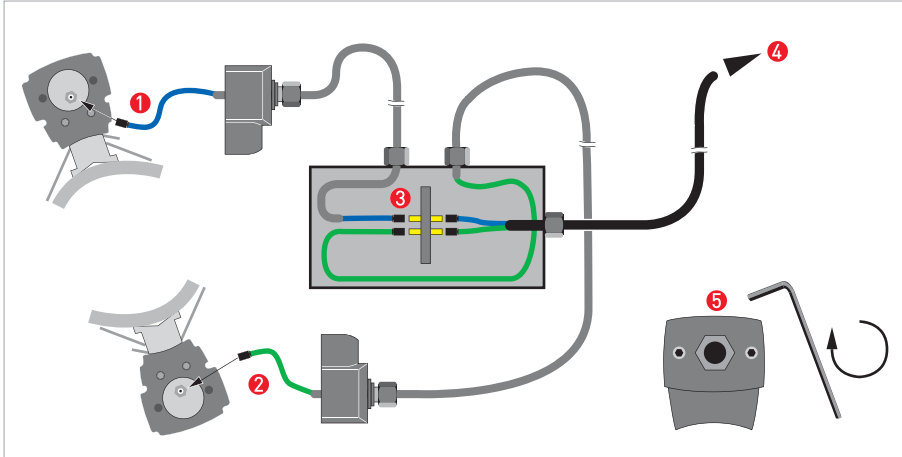


Figure 5-11: Connections in cable box (large version)

- 1 Connect the blue cable to the UP rail.
- 2 Connect the green cable to the DOWN rail.
- 3 Make connections in cable box.
- 4 Cable to converter
- 5 Turn the screws clockwise to secure the caps.

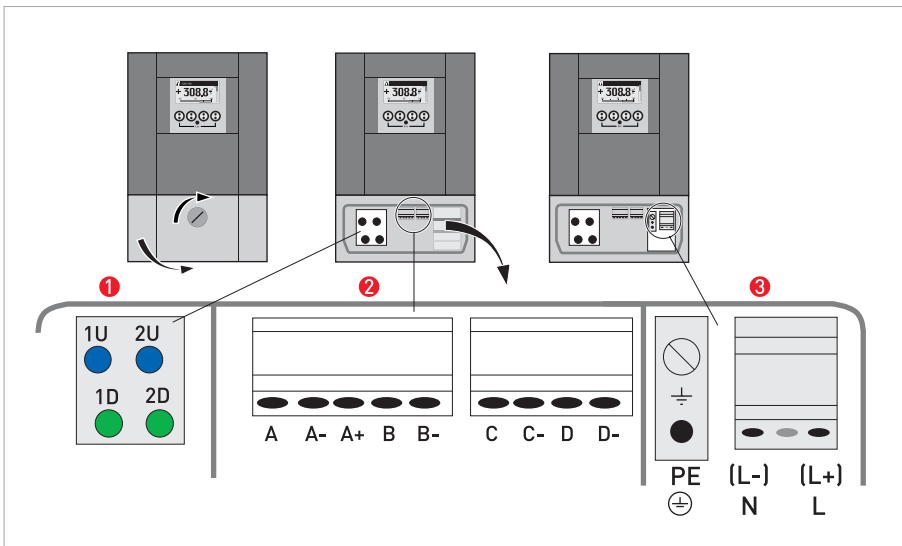


Figure 5-12: Construction of TWS 9000 W (wall)

- 1 Connect blue cable to 1U (to 2U for 2nd sensor) and the green cable to 1D (2D for 2nd sensor)
- 2 Communication I/O
- 3 Power supply: 24 VAC/DC or 100...240 VAC

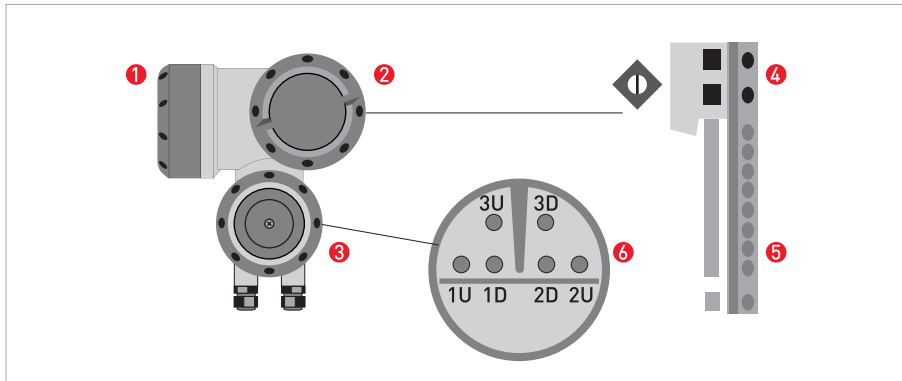


Figure 5-13: Construction of TWS 9000 F (field)

- ① Cover, electronics compartment
- ② Cover, terminal compartment for power supply and inputs/outputs
- ③ Cover, sensor terminal compartment
- ④ Cable entry for power
- ⑤ Cable entry for inputs/outputs
- ⑥ Cable entry for sensor cable

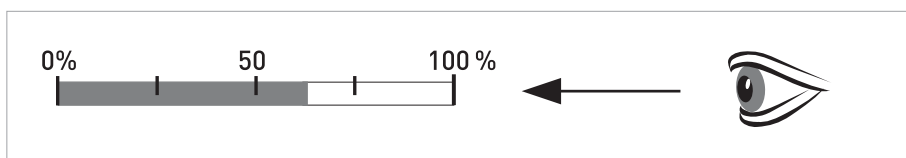


INFORMATION!

See also the section "Installation menu" in chapter "General instructions for programming".



- Go through menu X1...X7 as described in section "Installation menu" in chapter "General instructions for programming". Correct X5 if needed.
- X9.1: Press enter
- X9.2: Press enter
- X9.3: Press enter
- X9.4: Press enter
- X9.5: Read the preliminary volume flow. Press enter
- X9.6: Check signal



CAUTION!

Advice on signal strength:

Signal > 75%: good signal, optimization loop not needed

Signal 50...75%: fairly good signal, optimization loop can improve the signal

Signal 10...50%: low signal, optimization loop needed

Signal < 10%: bad or no signal, check settings in menu X6, increase transducer distance and/or go into the optimization loop.



- X9.7: Confirm or adjust the reading with the actual distance on the rail.
- X9.8: Optimization loop. Repeat steps X9.8.1...X9.8.5 until the advised mounting distance does not change more than 0.5%.
 - X9.8.1: Optimise distance?
 - X9.8.2: Read the velocity of sound of the fluid
 - X9.8.3: Continue?
 - X9.8.4: Confirm or adjust the velocity of sound
 - X9.8.5: Read the advised mounting distance and reposition the transducer
- X9.9: Read the preliminary volume flow
- X9.10: Path ready? If you enter "No" then the installation is not saved. If you enter "Yes" the installation can be saved in X9.12. If you have:
 - 1 path or pipe: you are finished, proceed with X9.12
 - 2 paths or pipes: go to X10 for the 2nd sensor
- X9.12: End Installation? If you enter "No" the installation is not saved, go to X9. If you enter "Yes" the installation is saved and the measurement screen will appear.
- Mount the cover (see section "mounting the cover" in chapter "General mechanical installation")

6.1 Menu overview

X installation

X1	language
X2	GDC IR interface
X3	units
X4	number of pipes
X5	number of paths
X6	pipe data
X6	pipe data 1
X7	pipe data 2
X9	install transd. 1
X10	install transd. 2
X12	transducer sets

A quick setup

A1	language
A2	Tag
A3	reset
A4	analog outputs
A5	digital outputs
A6	GDC IR interface

B test

B1	simulation
B2	actual values
B3	information

C setup

C1	process input 1
C2	process input 2
C1	process input
C4	transducer sets
C5	IO
C6	IO Counter
C7	IO HART
C8	device



INFORMATION!

You find the description of the *X Installation* menu in Chapter 5 of this handbook

6.2 Menu structure

6.2.1 Quick setup

A1	language		>	english / german / french	↑ ↓	↵
A2	Tag		>	fill in using ↑ ↓ >		↵
A3	reset		>	A3.1, A3.2,...	↑ ↓	
	A3.1	reset errors		yes/no	↑ ↓	↵
	A3.2	counter 1		yes/no	↑ ↓	↵
	A3.3	counter 2		yes/no	↑ ↓	
(underneath counter becomes active if modular IO)						
	A3.4	counter 3		yes/no	↑ ↓	↵
(end)						
A4	analog outputs		>	A4.1, A4.2,...	↑ ↓	
	A4.1	measurement	>	select from list using ↑ ↓ >		↵
				use at all outputs	↑ ↓	
				yes/no		↵
				if no:	only HART current output is selected	
				if yes:	all analog outputs are selected	
	A4.2	unit	>	select from list using ↑ ↓ >		↵
	A4.3	range	>	fill in using ↑ ↓ >		↵
				use at all outputs	↑ ↓	
				yes/no		↵
				if no:	only HART current output is selected	
				if yes:	all analog outputs are selected	
	A4.4	low flow cutoff	>	fill in using ↑ ↓ >		↵
				use at all outputs	↑ ↓	
				yes/no		↵
				if no:	only HART current output is selected	
				if yes:	all analog outputs are selected	
	A4.5	time constant	>	fill in using ↑ ↓ >		↵
				use at all outputs	↑ ↓	
				yes/no		↵
				if no:	only HART current output is selected	
				if yes:	all analog outputs are selected	
A5	digital outputs		>	A5.1, A5.2,...	↑ ↓	

A5.1	measurement	>	select from list using ↑ ↓ >		↵
			use at all outputs	↑ ↓	
			yes/no		↵
			if no:	only pulse output D is selected	
			if yes:	all digital outputs are selected	
A5.2	pulse value unit	>	fill in using ↑ ↓ >		↵
			use at all outputs	↑ ↓	
			yes/no		↵
			if no:	only pulse output D is selected	
			if yes:	all digital outputs are selected	
A5.3	value p. pulse	>	fill in using ↑ ↓ >		↵
			use at all outputs	↑ ↓	
			yes/no		↵
			if no:	only pulse output D is selected	
			if yes:	all digital outputs are selected	
A5.4	low flow cutoff	>	fill in using ↑ ↓ >		↵
			use at all outputs	↑ ↓	
			yes/no		↵
			if no:	only pulse output D is selected	
			if yes:	all digital outputs are selected	
A6	GDC IR interface	>	activate/cancel	↑ ↓	↵

6.2.2 Test

B1	simulation		>	B1.1, B1.2,...	↑↓	
	B1.1	volume flow	>	set value/cancel	↑↓	
				start simulation	↑↓	
				yes/no		↵
(underneath B1.1 until B1.3 become active if two pipes or two paths are selected in X4 and X5)						
	B1.1	volume flow 1	>	set value/cancel	↑↓	
				start simulation	↑↓	
				yes/no		↵
	B1.2	volume flow 2	>	submenu identical to B1.1	↑↓	
(end)						
	B1.4	vel. of sound	>	set value/cancel	↑↓	
				start simulation	↑↓	
				yes/no		↵
(underneath B1.4 until B1.5 become active if two pipes or two paths are selected in X4 and X5)						
	B1.4	vel. of sound 1	>		↑↓	
				set value/cancel		
				start simulation	↑↓	
				yes/no		↵
	B1.5	vel. of sound 2	>	submenu identical to B1.4	↑↓	
(end)						
	B1.7	terminal A (depends on IO setting hardware)	>	select from list using ↑↓>		↵
	B1.8	terminal B (depends on IO setting hardware)	>	select from list using ↑↓>		↵
	B1.9	terminal C (depends on IO setting hardware)	>	select from list using ↑↓>		↵
	B1.10	terminal D (depends on IO setting hardware)	>	select from list using ↑↓>		↵
B2	actual values		>		↑↓	
	B.2.1	act. volume flow	>		↑↓	
(underneath B2.1.1 until B2.1.2 become active if two pipes or two paths are selected in X4 and X5)						
	B2.1.1	pipe 1		read		↵
	B2.1.2	pipe 2		read		↵
(end)						
	B.2.2	act. mass flow	>		↑↓	
(additional menus for two pipes or two paths)						
	B.2.3	act. Reynolds nr.	>		↑↓	
(additional menus for two pipes or two paths)						

	B.2.4	act. vel. of sound	>		↑↓	
	(additional menus for two pipes or two paths)					
	B.2.5	act. flow speed	>		↑↓	
	(additional menus for two pipes or two paths)					
	B.2.6	act. gain	>		↑↓	
	(additional menus for two pipes or two paths)					
	B.2.7	act. SNR	>		↑↓	
	(additional menus for two pipes or two paths)					
	B.2.8	act. signal quality	>		↑↓	
	(additional menus for two pipes or two paths)					
	B.2.9	operating hours	>		↑↓	
B3	information	>		B3.1, B3.2,...	↑↓	
	B3.1	C number		read		↵
	B3.2	process input			↑↓	
	B3.2.1	sensor CPU		read		↵
	B3.2.2	sensor DSP		read		↵
	B3.2.3	sensor driver		read		↵
	B3.3	device		sernr/swnr/yymm dd	↑↓	↵
	B3.4	display		sernr/swnr/yymm dd	↑↓	↵

6.2.3 Setup

C	setup	>		↑ ↓	
[underneath C1 becomes active if two pipes are selected in X4]					
C1	process input 1	>	C1.1, C1.3,...	↑ ↓	←
	C1.1	number of pipes	>	read	←
	C1.3	pipe data	>	C1.3.1	↑ ↓
	C1.3.1	pipe tag			
[further submenus C1.3.2 up to C1.3.12 are identical to X6.2 up to X6.13]					
	C1.4	transducer data	>	C1.4.1,...	↑ ↓ ←
	C1.4.1	transducer set	>	Ta,Tb,Tc,none	↑ ↓ ←
	C1.4.2	number of traverses	>	1,2,4	↑ ↓ ←
	C1.4.3	actual distance	>	fill in using ↑ ↓ >	←
	C1.5	extra measurements	>	select on pipe 1, on pipe 2	←
	C1.6	calibration	>	C1.6.1, C1.6.2,...	↑ ↓
	C1.6.1	zero calibration	>	calibrate zero ?	select cancel, automatic, default
	C1.6.2	meter factor	>	fill in using ↑ ↓ >	←
	C1.6.3	Reynolds correction	>	on,off	↑ ↓ ←
	C1.7	filter	>	C1.7.1, C1.7.2,...	↑ ↓ ←
	C1.7.1	limitation	>	fill in using ↑ ↓ >	←
	C1.7.2	flow direction	>	normal/reverse	↑ ↓ ←
	C1.7.3	time constant	>	fill in using ↑ ↓ >	←
	C1.7.4	low flow cutoff	>	fill in using ↑ ↓ >	←
	C1.8	simulation	>	C1.8.1, C1.8.2,...	↑ ↓ ←
	C1.8.1	volume flow	>	set value/cancel	↑ ↓
				start simulation	↑ ↓
				yes/no	←
	C1.8.2	vel. of sound	>		↑ ↓
				set value/cancel	↑ ↓
				start simulation	↑ ↓
				yes/no	←
	C1.9	plausibility	>	C1.9.1, C1.9.2,...	↑ ↓ ←
	C1.9.1	error limit	>	fill in using ↑ ↓ >	←
	C1.9.2	counter decrease	>	fill in using ↑ ↓ >	←
	C1.9.3	counter limit	>	fill in using ↑ ↓ >	←
	C1.10	information	>	C1.10.1, C1.10.2,...	↑ ↓ ←
	C1.10.1	sensor CPU		read	
	C1.10.2	sensor DSP		read	←
	C1.10.3	sensor driver		read	←
	C1.11	diagnosis value	>	fill in using ↑ ↓ >	←

C2	process input 2		>		↑ ↓	
[further submenus C2.1 up to C2.11 are identical to C1.1 up to C1.11]						
[end]						
[underneath C1 becomes active if two paths are selected in X5]						
C1	process input		>	C1.1, C1.2,...	↑ ↓	
	C1.1	number of pipes	>	read		←
	C1.2	pipe 1: total paths	>	read		←
	C1.3	pipe data	>	C1.3.1, C1.3.2,...	↑ ↓	←
	C1.3.1	pipe tag				
[further submenus C1.3.2 up to C1.3.12 are identical to X6.2 up to X6.13]						
	C1.4	transducer data	>	C1.4.1, C1.4.2,...	↑ ↓	
	C1.4.1	transducer set 1	>	Ta,Tb,Tc,none	↑ ↓	←
	C1.4.2	number of traverses 1	>	1,2,4	↑ ↓	←
	C1.4.3	actual distance 1	>	fill in using ↑ ↓ >	↑ ↓	
	C1.4.4	transducer set 2	>	Ta,Tb,Tc,none	↑ ↓	←
	C1.4.5	number of traverses 2	>	1,2,4	↑ ↓	←
	C1.4.6	actual distance 2	>	fill in using ↑ ↓ >	↑ ↓	
	C1.6	calibration	>	C1.6.1, C1.6.2,...	↑ ↓	←
	C1.6.1	zero calibration	>	calibrate zero ?	select cancel, automatic, default	
	C1.6.2	meter factor	>	fill in using ↑ ↓ >		←
	C1.6.3	Reynolds correction	>	on,off	↑ ↓	←
	C1.7	filter	>	C1.7.1, C1.7.2,...	↑ ↓	←
	C1.7.1	limitation	>	fill in using ↑ ↓ >		←
	C1.7.2	flow direction	>	normal/reverse	↑ ↓	←
	C1.7.3	time constant	>	fill in using ↑ ↓ >		←
	C1.7.4	low flow cutoff	>	fill in using ↑ ↓ >		←
	C1.8	simulation	>	C1.8.1, C1.8.2,...	↑ ↓	←
	C1.8.1	volume flow	>	set value/cancel	↑ ↓	
				start simulation	↑ ↓	
				yes/no		
	C1.8.2	vel. of sound	>	set value/cancel	↑ ↓	
				start simulation	↑ ↓	
				yes/no		
	C1.9	plausibility	>	C1.9.1, C1.9.2,...	↑ ↓	←
	C1.9.1	error limit	>	fill in using ↑ ↓ >		←
	C1.9.2	counter decrease	>	fill in using ↑ ↓ >		←
	C1.9.3	counter limit	>	fill in using ↑ ↓ >		←
	C1.10	information	>	C1.10.1, C1.10.2,...	↑ ↓	←
	C1.10.1	sensor CPU		read		←
	C1.10.2	sensor DSP		read		←

	C1.10.3	sensor driver		read		←
	C1.11	diagnosis value	>	fill in using ↑ ↓ >		←
C4	transducer sets		>	C4.1, C4.2,...	↑ ↓	←
	C4.1	Ta serial no.	>	fill in using ↑ ↓ >		←
	C4.2	Ta calibration no.	>	fill in using ↑ ↓ >		←
	C4.3	Tb serial no.	>	fill in using ↑ ↓ >		←
	C4.4	Tb calibration no.	>	fill in using ↑ ↓ >		←
	C4.5	Tc serial no.	>	fill in using ↑ ↓ >		←
	C4.6	Tc calibration no.	>	fill in using ↑ ↓ >		←
C5	I/O		>	C5.1, C5.2,...	↑ ↓	
	C5.1	hardware	>	C5.1.1, C5.1.2,...	↑ ↓	←
	C5.1.1	terminals A	>	select current output/off using ↑ ↓		←
	C5.1.2	terminals B	>	select from list using ↑ ↓		←
	C5.1.3	terminals C	>	select from list using ↑ ↓		←
	C5.1.4	terminals D	>	select from list using ↑ ↓		←
	C5.2	current out A	>	C5.2.1, C5.2.2,...	↑ ↓	←
	C5.2.1	range 0-100%	>	fill in using ↑ ↓ >		←
	C5.2.2	extended range	>	fill in using ↑ ↓ >		←
	C5.2.3	error current	>	fill in using ↑ ↓ >		←
	C5.2.4	error condition	>	select from list using ↑ ↓		←
	C5.2.5	measurement	>	select from list using ↑ ↓		←
	C5.2.6	range	>	fill in using ↑ ↓ >		←
	C5.2.7	polarity	>	select from list using ↑ ↓		←
	C5.2.8	limitation	>	fill in using ↑ ↓ >		←
	C5.2.9	low flow cutoff	>	fill in using ↑ ↓ >		←
	C5.2.10	time constant	>	fill in using ↑ ↓ >		←
	C5.2.11	special function	>	select from list using ↑ ↓		←
	C5.2.12	threshold	>	fill in using ↑ ↓ >		←
	C5.2.13	information	>	read		←
	C5.2.14	simulation	>	select set on/off/cancel		←
	C5.2.15	4 mA trimming	>	fill in using ↑ ↓ >		←
	C5.2.16	20 mA trimming	>	fill in using ↑ ↓ >		←
	C5.3	frequency out X	>	C5.3.1, C5.3.2,...	↑ ↓	←
	C5.3.1	pulse shape	>	select from list using ↑ ↓		←
	C5.3.2	pulse width	>	fill in using ↑ ↓ >		←
	C5.3.3	100 % pulse rate	>	fill in using ↑ ↓ >		←

C5.3.4	measurement	>	select from list using ↑↓		←
C5.3.5	range	>	fill in using ↑↓>		←
C5.3.6	polarity	>	select from list using ↑↓		←
C5.3.7	limitation	>	fill in using ↑↓>		←
C5.3.8	low flow cutoff	>	fill in using ↑↓>		←
C5.3.9	time constant	>	fill in using ↑↓>		←
C5.3.10	invert signal	>	fill in using ↑↓>		←
C5.3.11	phase shift	>	select from list using ↑↓		←
C5.3.12	special function	>	fill in using ↑↓>		←
C5.3.13	information	>	read		←
C5.3.14	simulation	>	select set on/off/cancel		←
C5.4	pulse output X	>	C5.4.1, C5.4.2,...	↑↓	←
C5.4.1	pulse shape	>	select from list using ↑↓		←
C5.4.2	pulse width		fill in using ↑↓>		←
C5.4.3	max. pulse rate	>	fill in using ↑↓>		←
C5.4.4	measurement	>	select from list using ↑↓		←
C5.4.5	pulse value unit	>	fill in using ↑↓>		←
C5.4.6	value p. pulse	>	fill in using ↑↓>		←
C5.4.7	polarity	>	select from list using ↑↓		←
C5.4.8	low flow cutoff	>	fill in using ↑↓>		←
C5.4.9	time constant	>	fill in using ↑↓>		←
C5.4.10	invert signal	>	select on/off		←
C5.4.11	phase shift		select from list using ↑↓		←
C5.4.12	special function		select from list using ↑↓		←
C5.4.13	information	>	read		←
C5.4.14	simulation	>	select set on/off/cancel		←
C5.5	status output X	>	C5.5.1, C5.5.2,...	↑↓	←
C5.5.1	mode	>	select from list using ↑↓		←
C5.5.2	current output Y	>	select from list using ↑↓		←
C5.5.3	frequency output Y	>	select from list using ↑↓		←
C5.5.4	pulse output Y	>	select from list using ↑↓		←
C5.5.5	status output Y	>	select from list using ↑↓		←
C5.5.6	limit switch Y	>	read: status off		←

	C5.5.7	control input Y	>		read: status off		←
	C5.5.8	off	>		read: status off		←
	C5.5.9	invert signal	>		select on/off		←
	C5.5.10	information	>		read		←
	C5.5.11	simulation	>		select set on/off/cancel		←
	C5.6	limit switch X	>		C5.6.1, C5.6.2,...	↑ ↓	←
	C5.6.1	measurement	>		select from list using ↑ ↓		←
	C5.6.2	threshold	>		fill in using ↑ ↓ >		←
	C5.6.3	polarity	>		select from list using ↑ ↓		←
	C5.6.4	time constant	>		fill in using ↑ ↓ >		←
	C5.6.5	invert signal	>		select on/off		←
	C5.6.6	information	>		read		←
	C5.6.7	simulation	>		select set on/off/cancel		←
	C5.7	control input X	>		C5.7.1, C5.7.2,...	↑ ↓	←
	C5.7.1	mode	>		select from list using ↑ ↓		←
	C5.7.2	invert signal	>		select on/off		←
	C5.7.3	information	>		read		←
	C5.7.4	simulation	>		select set on/off/cancel		←
[active if HART device]							
	C6	I/O Counter	>		C6.1, C6.2	↑ ↓	
	C6.1	counter 1	>		C6.1.1, C6.1.2,...	↑ ↓	←
	C6.1.1	function of counter	>		select from list using ↑ ↓		←
	C6.1.2	measurement	>		select from list using ↑ ↓		←
	C6.1.3	low flow cutoff	>		fill in using ↑ ↓ >		←
	C6.1.4	time constant	>		fill in using ↑ ↓ >		←
	C6.1.5	preset value	>		fill in using ↑ ↓ >		←
	C6.1.6	reset counter	>		select yes/no		←
	C6.1.7	set counter	>		select set on/off/cancel		←
	C6.1.8	stop counter	>		select yes/no		←
	C6.1.9	start counter	>		select yes/no		←
	C6.1.10	information	>		read		←
	C6.2	counter 2	>		C6.2.1, C6.2.2,...	↑ ↓	
(underneath submenus identical to C6.1.1 to C6.1.10)							
	C7	I/O HART	>		C7.1, C7.2,...	↑ ↓	
	C7.1	PV is	>		C7.1.1, C7.1.2,...	↑ ↓	←
	C7.1.1	current output A	>		read		←
[depends on I/O configuration]							

	C7.1.2	frequency output X	>	read		↵
	C7.1.3	HART dynamic variable	>	select from list using ↑ ↓		↵
	C7.2	SV is	>	C7.2.1		
	C7.2.1	HART dynamic variable	>	select from list using ↑ ↓		↵
	C7.3	TV is	>	C7.3.1		
	C7.3.1	HART dynamic variable	>	select from list using ↑ ↓		↵
	C7.4	4V is	>	C7.4.1		
	C7.4.1	HART dynamic variable	>	select from list using ↑ ↓		↵
(end)						
C8	device		>	C8.1, C8.2,...	↑ ↓	
	C8.1	device info	>	C8.1.1, C8.1.2,...	↑ ↓	↵
	C8.1.1	Tag	>	fill in using ↑ ↓ >		↵
	C8.1.2	C number	>	read		↵
	C8.1.3	device serial no.	>	read		↵
	C8.1.4	electronic serial no.	>	read		↵
	C8.1.5	information	>	read		↵
	C8.2	display	>	C8.2.1, C8.2.2,...	↑ ↓	↵
	C8.2.1	language	>	select from list using ↑ ↓		↵
	C8.2.2	contrast	>	fill in using ↑ ↓ >		↵
	C8.2.3	default display	>	select from list using ↑ ↓		↵
	C8.2.5	information	>	read		↵
	C8.3	1. meas. page	>	C8.3.1, C8.3.2,...	↑ ↓	
	C8.3.1	function	>	select from list using ↑ ↓		↵
(if two or three lines: C5.3.8 etc active)						
	C8.3.2	measurement 1.line	>	select from list using ↑ ↓		↵
	C8.3.3	range	>	fill in using ↑ ↓ >		↵
	C8.3.4	limitation	>	fill in using ↑ ↓ >		↵
	C8.3.5	low flow cutoff	>	fill in using ↑ ↓ >		↵
	C8.3.6	time constant	>	fill in using ↑ ↓ >		↵
	C8.3.7	format 1.line	>	select from list using ↑ ↓		↵
	C8.3.8	measurement 2.line	>	select from list using ↑ ↓		↵
	C8.3.9	format 2.line	>	select from list using ↑ ↓		↵
	C8.3.10	measurement 3.line	>	select from list using ↑ ↓		↵

C8.3.11	format 3.line	>	select from list using ↑↓		↵
C8.4	2. meas. page	>	C8.4.1, C8.4.2,...	↑↓	
(underneath submenus identical to C8.3.1 to C8.3.11)					
C8.5	graphic page	>	C8.5.1, C8.5.2,...	↑↓	↵
C8.5.1	select range	>	select manual/automatic		↵
C8.5.2	range	>	fill in using ↑↓>		↵
C8.5.3	time scale	>	fill in using ↑↓>		↵
C8.6	special functions	>	C8.6.1, C8.6.2,...	↑↓	↵
C8.6.1	reset errors	>	select yes/o		↵
C8.6.2	save settings	>	select from list using ↑↓		↵
C8.6.3	load settings	>	select from list using ↑↓		↵
C8.6.4	password quick setup	>	fill in 4 digits using ↑↓>		↵
C8.6.5	password setup	>	fill in 4 digits using ↑↓>		↵
C8.6.6	GDC IR interface	>	activate/cancel		↵
C8.7	units	>	C8.7.1, C8.7.2,...	↑↓	↵
C8.7.1	size				
C8.7.2	volume flow	>	select from list using ↑↓		↵
C8.7.3	mass flow	>	select from list using ↑↓		↵
C8.7.4	velocity	>	select from list using ↑↓		↵
C8.7.5	volume flow	>	select from list using ↑↓		↵
C8.7.6	mass	>	select from list using ↑↓		↵
C8.7.7	density	>	select from list using ↑↓		↵
C8.7.8	viscosity	>	select from list using ↑↓		↵
C8.8	HART	>	C8.8.1, C8.8.2,...	↑↓	↵
C8.8.1	HART	>	select on/off		↵
C8.8.2	address	>	fill in 2 digits using ↑↓>		↵
C8.8.3	message	>	fill in using ↑↓>		↵
C8.8.4	description	>	fill in using ↑↓>		↵
C8.9	quick setup	>	C8.9.1, C8.9.2,...	↑↓	↵
C8.9.1	reset counter 1	>	select yes/no		↵
C8.9.2	reset counter 2	>	select yes/no		↵
C8.9.3	reset counter 3	>	select yes/no		↵

6.2.4 Customize settings

After installation the display switches to the first measurement screen.

The TWS 9000 has 4 different display pages:

- 2 measurement pages
- 1 graphical page
- 1 status page

Using the ↓↑ buttons, you can switch between the displayed pages.

Customizing used transducers sets:

To alter settings in the menu, keep button > pressed until "Release key now" appears in the display.

X12 transducer sets

X12	transducer sets		>	X12.1, X12.2,...	↑↓	
	X12.1	Ta serial no.	>	fill in using ↑ ↓ >		←
	X12.2	Ta calibration no.	>	fill in using ↑ ↓ >		←
	X12.3	Tb serial no.	>	fill in using ↑ ↓ >		←
	X12.4	Tb calibration no.	>	fill in using ↑ ↓ >		←
	X12.5	Tc serial no.	>	fill in using ↑ ↓ >		←
	X12.6	Tc calibration no.	>	fill in using ↑ ↓ >		←

6.3 Function description

Menu No.	Display	Function description	Selection list
X	Installation		
X3	units		
X3.1	size	unit for dimension	mm, inch
X3.2	volume flow	unit for volume flow	L/s, L/min,L/h, m3/s, m3/min, m3/h, m3/d, ft3/s, ft3/min, ft3/h, gal/s, gal/min,gal/h, gal/d, IG/s, IG/min, IG/h, IG/d, bbl/h, bbl/d, free unit
X3.3	velocity	unit for flow speed and velocity of sound (VoS)	m/s, ft/s
X3.4	density	unit for density	kg/L, kg/m3, lb/ft3, lb/gal, free unit
X3.5	viscosity	unit for viscosity	cSt, mm2/s
X5	number of paths	in case "2 paths" is selected, the measurement results will be averaged	1 path, 2 paths
X6.3	diameter	size for outer diameter of pipe	min-max: 20 - 4300 mm / 0.787 - 169.3 inch
X6.4	pipe material		carbon steel, stainless steel, cast iron, aluminum, concrete, GRF/RFP, asbestos cement, PP/PVC, acrylics, polyamide, other
X6.5	VoS pipe material		min-max: 1000.0 - 4500.0 m/s / 3280.8 - 14764 ft/s
X6.6	wall thickness		min-max: 1.000 - 200.0 mm / 0.039 - 7.874 inch
X6.7	liner material		cement, epoxy, PP, LDPE, HDPE, PTFE, rubber, other, none
X6.8	VoS liner material		min-max: 1000.0 - 4500.0 m/s / 3280.8 - 14764 ft/s
X6.9	liner thickness		min-max: 0.100 - 20.00 mm / 0.004 - 0.787 inch
X6.10	fluid		water, alkanes, alcohols, oil, acids, CxHx refined, CxHx light, refrigerant, solvents, caustic soda, other
X6.11	VoS fluid		min-max: 500 - 2500 m/s / 1640.4 - 8202.1 ft/s
X6.12	density		min-max: 0.1000 - 5.0000 kg/l / 6.2428 lb/ft3 to 312.14 lb/ft3
X6.13	viscosity		min-max: 0.100 cSt to 9999 cSt (mm2/s)
X9.1	transducer set	short code for transducer set, mentioned on sensor	Ta, Tb, Tc, none
X9.7	actual distance		min-max: -10.00 - +9999 mm / -0.394 - +393.7 inch
X12.1/3/5	Tx serial no.	factory serial number of sensor	Ayy, 5 free units
X12.2/4/6	Tx calibration no.	set calibration number of sensor according to type sticker	9 free units

A Quick setup

A	quick setup		
A1	language		english, german, french, dutch
A2	Tag	unique location in plant	12 free selectable digits
A4	analog outputs	only active if HART device	current output A, B or C, pulse output A, B or D

Menu No.	Display	Function description	Selection list
A4.1	measurement	value for HART current output	(depends on pipe configuration: 1 or 2 pipes) volume flow, mass flow, VoS, flow speed, gain, SNR, diagnosis value, volume flow 1 or 2, VoS 1 or 2
A4.2	unit	unit for HART current output	L/s, L/min, L/h, m ³ /s, m ³ /min, m ³ /h, m ³ /d, ft ³ /s, ft ³ /min, ft ³ /h, gal/s, gal/min, gal/h, gal/d, IG/s, IG/min, IG/h, IG/d, bbl/h, bbl/d, free unit
A4.3	range	range for main HART current output	min-max: 0.00 - xxxx (depends on configuration)
A4.4	low flow cutoff	low flow cutoff for main HART current output	min-max: 00.0 - 20.0
A4.5	time constant	time constant for main HART current output	min-max: 000.1 - 100.0
A5	digital outputs	only active if HART device	pulse output A, B or D, counter 1
A5.1	measurement	value for pulse output	(depends on pipe configuration: 1 or 2 pipes) volume flow, mass flow, volume flow 1 or 2
A5.2	pulse value unit	unit for main pulse output	(unit class depends on selected measurement)
A5.3	value p. pulse	value of pulse per volume or mass for pulse output	(min-max depends on selected measurement)
A5.4	low flow cutoff	low flow cutoff for pulse output	(min-max depends on selected measurement)

B Test

B	test		
B1.7	terminal A	(depends on IO setting hardware)	current output A, frequency output A, pulse output A, status output A, limit switch A, control input A
B1.8	terminal B	(depends on IO setting hardware)	current output B, frequency output B, pulse output B, status output B, limit switch B, control input B
B1.9	terminal C	(depends on IO setting hardware)	current output C, status output C, limit switch C
B1.10	terminal D	(depends on IO setting hardware)	frequency output D, pulse output D, status output D, limit switch D
B3.1	C number	identification of electronics	also see converter sticker; first line: circuit board, second line: software, third line: calibration or production date
B3.2.1	Sensor CPU	identification of hardware and software for flow processing	also see sensor board of electronics
B3.2.2	Sensor DSP	identification of hardware and software for signal processing	also see sensor board of electronics
B3.2.3	Sensor driver	identification of hardware and software for driver part	also see sensor board of electronics
B3.3	Device	identification of circuit board	serial number of circuit board, main software version number, production date

C Setup

C	setup		
C1.5	extra measurements	extra available parameters for display or input/output	(only for dual pipe configuration: 1, 2 pipes) on pipe 1: mass flow, flow speed, gain, SNR on pipe 2: mass flow, flow speed, gain, SNR

Menu No.	Display	Function description	Selection list
C1.6.1	zero calibration	transit time offset at zero flow	cancel, default, automatic min-max: -10000 - +10000 ps
C1.6.2	meter factor	set factor for correction of volume flow, mass flow, flow speed and Reynolds number	min-max: 0.500 - 2.000
C1.6.3	Reynolds correction	set Reynolds correction for flow profile disturbances, effective on volume flow, mass flow	on,off
C1.7.1	limitation	set lower and upper limit for flow speed on all outputs	min-max: -100 - +100 m/s
C1.7.2	flow direction	select flow direction	normal, reverse
C1.7.3	time constant	within set time, measurements are averaged, displayed and sent to current output	min-max: 000.0 - 100.0 s
C1.7.4	low flow cutoff	beneath set flow speed, zero appears in display	min-max: 0.000 - 10.00 m/s / 0.000 - 32.81 ft/s
C1.8.2	vel. of sound	simulation of the VoS	min-max: 0.0000 - 2500.0 m/s / 0.0000 - 8202.1 ft/s
C1.9.1	error limit	with set limits, every erroneous measurement is counted as percentage of the measured values	min-max: 000 - 100 %
C1.9.2	counter decrease	amount with which the counter decreases	min-max: 00 - 99
C1.9.3	counter limit	totalized correct measurements equal to set counter decrease, decrease error limit by 1	min-max: 000 - 999
C1.11	diagnosis value	diagnosis of the flow measurement	signal quality, Reynolds number
C5.1	I/O Hardware		
C5.1.1	terminals A	assign terminal A	for basic I/O: current output, off for Modular I/O: free selectable 1st IO Module
C5.1.2	terminals B	assign terminal B	for basic I/O: status output, limit switch, control input for Modular I/O: free selectable 2nd IO Module
C5.1.3	terminals C	assign terminal C	for basic I/O: status output, limit switch, off for Modular I/O: fixed current out
C5.1.4	terminals D	assign terminal D	for basic I/O: status output, limit switch, pulse output, frequency output, off for Modular I/O: fixed current out
C5.2	current out A		
C5.2.1	range 0-100%	set current range	min-max: 04.0 - 20.0 mA
C5.2.2	extended range	set upper current range to extended value	min-max: 03.5 - 21.5 mA
C5.2.3	error current	after error this selected current is set	min-max: 03.0 - 22.0 mA
C5.2.4	error condition		error in device, out of specification, application error

Menu No.	Display	Function description	Selection list
C5.2.5	measurement	measurement value to current output	(depends on pipe configuration: 1 or 2) volume flow, mass flow, VoS, flow speed, gain, SNR, diagnosis value, volume flow 1 or 2, VoS 1 or 2
C5.2.6	range	set measurement range from 0 to 100 %	(min-max depends on parameter settings)
C5.2.7	polarity	set polarity of current output	positive -, negative -, both polarity(ies), absolute value
C5.2.8	limitation	set lower and upper limit for current output	min-max: -150 - +150 %
C5.2.9	low flow cutoff	beneath set value, current output is set to zero	min-max: 00.0 - 20.0
C5.2.10	time constant	within set time, measurements are averaged, displayed and sent to current output	min-max: 000.1 - 100.0
C5.2.11	special functions	for ranging	automatic range, external range, off
C5.2.12	threshold	inactive if C5.2.11 is set to off: set lag value between normal and extended range	min-max: 05.0 - 80.0
C5.2.13	information	serial number of circuit board, software version, calibration date of circuit board	
C5.2.14	simulation A	simulation of current output A	set value:on/off, cancel min-max: 00.0 - 22.0 mA
C5.2.15	4 mA trimming	restore factory setting for 4 mA	min-max: 3.6000 - 5.5000 mA
C5.2.16	20 mA trimming	restore factory setting for 20 mA	min-max: 18.500 - 21.500 mA
C5.3	frequency output		
C5.3.1	pulse shape	set shape	symmetric, automatic, fixed
C5.3.2	pulse width	active if C2.3.1 is set to fixed: set time for pulse activation	min-max: 0000.05 - 2000.00
C5.3.3	100 % pulse rate		min-max: 00000.0 - 10000.0
C5.3.4	measurement	measurement value to frequency output	(depends on pipe configuration: 1 or 2 pipes) volume flow, mass flow, VoS, flow speed, gain, SNR, diagnosis value, volume flow 1 or 2, VoS 1 or 2
C5.3.5	range	set measurement range from 0 to 100 %	(min-max depends on parameter settings)
C5.3.6	polarity	set polarity of frequency output	both polarities
C5.3.7	limitation	set lower and upper limit for frequency output	min-max: -150 - +150 %
C5.3.8	low flow cutoff	set low values to zero	min-max: 00.0 - 20.0
C5.3.9	time constant	within set time, measurements are averaged, displayed and sent to current output	min-max: 000.1 - 100.0
C5.3.10	invert signal	define frequency output activation	off: activate high current/switch closed on: low current/switch open
C5.3.11	phase shift	phase shift between output B and D	0, 90, 180 degrees
C5.3.12	special function	for ranging	off, phase shift
C5.3.13	information		

Menu No.	Display	Function description	Selection list
C5.3.14	simulation	simulation of frequency output	on, off, cancel
C5.4	pulse output		
C5.4.1	pulse shape	set shape	symmetric, automatic, fixed
C5.4.2	pulse width	set time for pulse activation	available if pulse shape is set: fixed min-max: 0000.05 - 2000.00
C5.4.3	max. pulse rate		min-max: 00000.0 - 10000.0 Hz
C5.4.4	measurement	measurement value to pulse output	(depends on pipe configuration: 1 or 2 pipes) volume flow, mass flow, volume flow 1 or 2
C5.4.5	pulse value unit	unit for pulse output	mL, L, free unit
C5.4.6	value p. pulse	value of pulse per volume or mass for pulse output	no min-max
C5.4.7	polarity	set polarity of pulse output	positive -, negative -, both polarity(ies), absolute value
C5.4.8	low flow cutoff	set low values to zero	min-max: 00.0 - 20.0
C5.4.9	time constant	within set time, measurements are averaged, displayed and sent to current output	min-max: 000.1 - 100.0
C5.4.10	invert signal	activate switch closed, open	off, on
C5.4.11	phase shift	phase shift between output B and D	0, 90, 180 degrees
C5.4.12	special function	for ranging	off, phase shift
C5.4.13	information	serial number of circuit board, software version, calibration date of circuit board	
C5.4.14	simulation	simulation of pulse output	on, off, cancel
C5.5	status output		
C5.5.1	mode	output is activated if an error occurs	(depends on pipe configuration: 1 or 2 pipes) off, error in device, application error, out of specification, empty pipe, polarity flow, over range flow, application error 1 or 2, out of specification 1 or 2, empty pipe 1 or 2, polarity flow 1 or 2, over range flow 1 or 2, counter 1 preset, counter 2 preset, output A/B/C/D
C5.5.2	current output Y	active if selected under status output mode (C2.5.1) output Y and output is current output	polarity, over range, automatic range
C5.5.3	frequency output Y	active if selected under status output mode (C2.5.1) output Y and output is frequency output	polarity, over range
C5.5.4	pulse output D	active if selected under status output mode (C2.5.1) output Y and output is pulse output	polarity, over range
C5.5.5	status output Y	active if selected under status output mode (C2.5.1) output Y and output is status output	same signal, inverted signal
C5.5.6	limit switch Y	active if selected under status output mode (C2.5.1) output Y and output is limit switch	off
C5.5.7	control input Y	active if selected under status output mode (C2.5.1) output Y and output is control input	off

Menu No.	Display	Function description	Selection list
C5.5.8	off	active if selected under status output mode (C2.5.1) output Y and output is switched off	off
C5.5.9	invert signal	define status output activation	off: activate high current/switch closed on: low current/switch open
C5.5.10	information	serial number of circuit board, software version, calibration date of circuit board	
C5.5.11	simulation	simulation of status output	on, off, cancel
C5.6	limit switch X		
C5.6.1	measurement	measurement value to limit switch	(depends on pipe configuration: 1 or 2 pipes) volume flow, mass flow, VoS, flow speed, gain, SNR, diagnosis value, volume flow 1 or 2, VoS 1 or 2
C5.6.2	threshold	1e: switch level 2e:time lag	min-max: 500.0 - 2500 m/s
C5.6.3	polarity	set polarity of limit switch	positive -, negative -, both polarity(ies), absolute value
C5.6.4	time constant	within set time, measurements are averaged, displayed and sent to current output	min-max: 000.1 - 100.0
C5.6.5	invert signal	define limit switch activation	off: high current by exceeded limit on: low current by exceeded limit
C5.6.6	information	serial number of circuit board, software version, calibration date of circuit board	
C5.6.7	simulation	simulation of limit switch	on, off, cancel
C5.7	control input X		
C5.7.1	mode	define function of control input	off, hold all outputs, hold output X, all outputs to zero, output X to zero, reset to all counters, reset counter X, stop all counters, stop counter X, zero outp.+ stop cnt, range change X, error reset
C5.7.2	invert signal		off: activate a current on: activate no current
C5.7.3	information	serial number of circuit board, software version, calibration date of circuit board	
C5.7.4	simulation	simulation of control input	on, off, cancel
C6	I/O Counter		
C6.1...6.2	Counter 1 and 2	only if HART device	
C.x.1	function of counter	define counter	off, +counter, -counter, sum counters
C.x.2	measurement	select the measurement for the counter	(depends on pipe configuration: 1 or 2 pipes) volume flow, mass flow, volume flow 1 or 2
C.x.3	low flow cutoff	set low values to zero	(depends on parameter settings)
C.x.4	time constant	within set time, measurements are averaged, displayed and sent to current output	min-max: 000.1 - 100.0
C.x.5	preset value	active when under status output mode (C2.5.1) preset counter X is selected	min-max: 0.00000 - 1.00 +15

Menu No.	Display	Function description	Selection list
C.x.6	reset counter		yes/no
C.x.7	set counter	select set value	on, off, cancel
C.x.8	stop counter	stop counter and hold actual value	yes/no
C.x.9	start counter	start after stop counter	yes/no
C.x.10	information	serial number of circuit board, software version, calibration date of circuit board	
C7	I/O HART	only if HART device; HART dynamic values are linked to analog outputs	free selectable only if analog output is NOT active
C7.1	PV is	Primary Variable; linked to HART current output	
C7.1.1	current output A	show selected value	
C7.1.2	frequency output X	show selected value	
C7.1.3	HART dynamic variable	select the variable	(depends on pipe configuration: 1 or 2 pipes) volume flow, mass flow, VoS, flow speed, gain, SNR, diagnosis value, volume flow 1 or 2, VoS 1 or 2, counter 1 or 2, operating hours
C7.2	SV is	Secondary Variable; linked to frequency output D	
C7.3	TV is	Third Variable	
C7.4	4V is	Fourth Variable	
C8	device		
C8.2.2	contrast		min-max: -9 - +9
C8.2.3	default display		1.meas.page, 2.meas.page, graphic page, status page, none
C8.3		settings for first and second measurement display	
C8.3.1	function		one, two, three line(s)
C8.3.2	measurement 1.line		(depends on pipe configuration: 1 or 2 pipes) volume flow, mass flow, VoS, flow speed, gain, SNR, diagnosis value, volume flow 1 or 2, VoS 1 or 2
C8.3.3	range	set measurement range from 0 to 100 %	(depends on parameter settings)
C8.3.4	limitation	set lower and upper limit	min-max: -150 - +150 %
C8.3.5	low flow cutoff	set low values to zero	min-max: 00.0 - 20.0
C8.3.6	time constant	within set time, measurements are averaged, displayed and sent to current output	min-max: 000.1 - 100.0
C8.3.7	format 1.line	number of decimals	automatic, No.x.xxxx (no - four decimals)
C8.3.8	measurement 2.line		bargraph, operating hours, counter 1, counter 2, diagnosis value, SNR, gain, flow speed, mass flow, VoS, volume flow
C8.5.1	select range	set Y-axis scaling	manual, automatic
C8.5.2	range	active if under select range (C5.5.1) manual is selected	min-max: -100 - +100%
C8.5.3	time scale	set X-axis scaling	min-max: 001 - 100 min

Menu No.	Display	Function description	Selection list
C8.6.2	save settings		factory settings, back up 1, back up 2, cancel
C8.6.3	load settings		factory settings, back up 1, back up 2, cancel
C8.6.4	password quick setup		0000 - 9999
C8.6.5	password setup		0000 - 9999
C8.7	units		
C8.7.1	volume flow		L/s, L/min, L/h, m ³ /s, m ³ /min, m ³ /h, m ³ /d, ft ³ /s, ft ³ /min, ft ³ /h, gal/s, gal/min, gal/h, gal/d, IG/s, IG/min, IG/h, IG/d, bbl/h, bbl/d, free unit
C8.7.2	mass flow		kg/s, kg/min, kg/h, t/min, t/h, t/d, lb/s, lb/min, lb/h, ST/min, ST/h, ST/d, LT/h, LT/d, gs, g/min, g/h, free unit
C8.7.3	flow speed		m/s, ft/s
C8.7.4	velocity		m/s, ft/s
C8.7.5	volume		m ³ , in ³ , ft ³ , yd ³ , mL, L, hL, gal, IG, bbl, free unit
C8.7.6	mass		mg, g, kg, t, oz, lb, ST, LT, free unit
C8.7.7	density		kg/L, kg/m ³ , lb/ft ³ , lb/gal, free unit
C8.7.8	viscosity		cSt, m ² /s, mm ² /s
C8.8.1	HART	factory setting: HART communication on; generates F: application error open circuit A	

6.4 Error messages

Error code	Group message	Error message	Description	Error handling
F	error in device		no measurement possible, measured values are not valid	repair or replace device and/or CPU; contact manufacturer service center
F	application error		no measurement possible, but device ok	check parameter settings / power off - wait 5 seconds - power on device
S	out of specification		unreliable measurement	maintenance required, check flowprofile
C	check in progress		test function is active, device is stand-by	wait until finished
I	information		no direct impact on measurements	no action needed
F		IO 1 (or IO 2)	error or failure of IO Module 1 (or 2)	try to load settings (menu C8.6.3); if error does not disappear, replace electronics unit
F		parameter	error or failure of data manager, parameter or hardware error	try to load settings (menu C8.6.3); if error does not disappear, replace electronics unit
F		configuration	incorrect configuration or no confirmation	confirm change of module; if configuration is unchanged, replace electronics unit
F		display	error of failure of display unit, parameter or hardware error	defect; replace electronics units
F		current output A (or B, C)	error or failure of the current output A (or B, C), parameter or hardware error	defect; replace electronics units
F		software user interface		defect; replace electronics units
F		hardware settings	detected hardware and set hardware settings do not match	follow display instructions
F		hardware detection	hardware can not be detected	defect; replace electronics units
F		RAM/ROM error IO 1 (or IO 2)		defect; replace electronics units
F		communication dsp-up	no communication between DSP and microprocessor PCB	contact manufacturer service center
F		front end	malfunctioning of front end PCB	contact manufacturer service center
F		uproc	malfunctioning of microcontroller PCB	contact manufacturer service center
F		dsp	malfunctioning of DSP	contact manufacturer service center
F		empty pipe	signal lost at two paths	check process conditions
F		flow > max 1	max volume flow exceeded for pipe 1	check parameter in menu C1.7.1
F		flow > max 2	max volume flow exceeded for pipe 2	check parameter in menu C1.7.1

Error code	Group message	Error message	Description	Error handling
F		open circuit A (or B, C)	current on current output A (or B, C) too low	check cable or reduce resistance (< 1000 Ohm)
F		over range A (or B, C)	current on current output A (or B, C) is limited by parameter setting	extend upper or lower limit for current output in menu C5.2.8
F		over range A (or B, D)	pulse on frequency output A (or B, D) is limited by parameter setting	extend upper or lower limit for frequency output in menu C5.3.7
F		active settings	error during CRC check (Cyclic Redundancy Check) of the active settings	load settings; factory setting, back up 1 or back up 2
F		factory settings	error during CRC check of factory settings	
F		back up 1 (or 2) settings	error during CRC check of back up 1 (or 2) settings	
F		signal lost path 1	signal lost at path 1	check signal cable / check for pipe obstructions
F		signal lost path 2	signal lost at path 2	check signal cable / check for pipe obstructions
F		pipe/sens1 param.	unrealistic parameter settings for pipe in combination with path 1	check parameters in menu X6
F		pipe/sens2 param.	unrealistic parameter settings for pipe in combination with path 2	check parameters in menu X6
S		unreliable 1	unreliable measurement at pipe 1	check process conditions for gas bubbles, solids
S		unreliable 2	unreliable measurement at pipe 2	check process conditions for gas bubbles, solids
S		zero converter	invalid value at power up	power off - wait 5 seconds - power on device
S		overflow counter 1 (or 2, 3)	counter is overflowing and will start again at zero	no action needed
S		backplane invalid	error during CRC check of backplane	restore data records on backplane
I		counter 1 (or 2, 3) stopped	counter has stopped	reset counter in menu C8.9.1 (or C8.9.2, C8.9.3)
I		control input A (or B) active	information only	no action needed
I		over range display 1 (or 2)	1 st row on 1 st (or 2 nd) measurement page is limited by parameter setting	extend upper or lower limit for limitation in menu C8.3.4
I		backplane sensor	incompatible data sensor on backplane	
I		backplane settings	incompatible data on backplane	
I		backplane difference	different data on backplane and display	
I		optical interface	optical interface is operational, local display can not be used	
I		softw sync error	incompatible DSP and microprocessor software	

7.1 Periodic maintenance

7.1.1 Regreasing of transducers

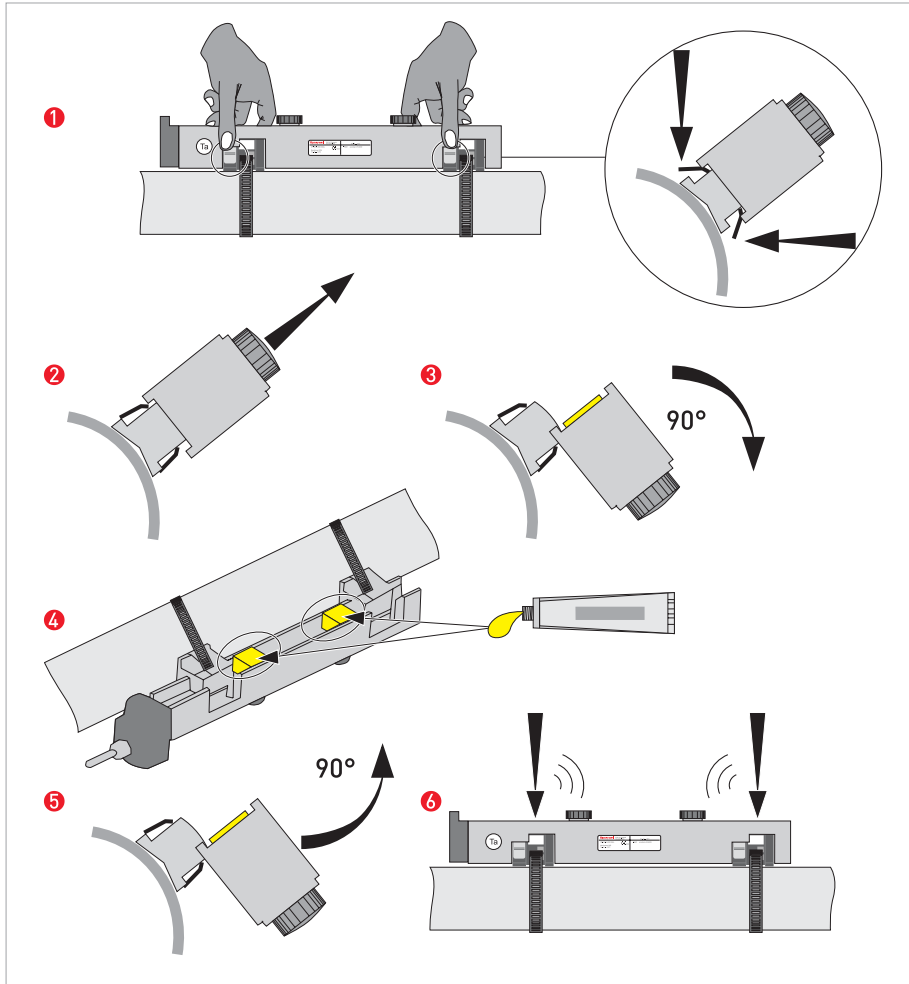


Figure 7-1: Greasing of transducers



- Loosen cover by unscrewing screw, slide cover away from connection cap, lift cover, place cover in safe place to avoid damage.
- Push buttons to release the rail ①.
- Lift rail upward ② and turn rail 90 degrees sideward ③.
Clean pipe and contact surfaces of transducers with a soft cloth.
- Regrease the contact surfaces of transducers ④.
- Turn rail 90 degrees back ⑤.
- Press rail at both ends to the pipe by clicking ⑥.

7.2 Cleaning

- Keep screw thread of the covers of the TWS 9000 F signal converter clean.
- Do not damage the screw thread and the gasket.
- Never allow dirt to accumulate.
- Grease the screw thread with Teflon grease.

7.3 Exchange of electronics unit

**CAUTION!**

The following instructions shall always be carefully followed and only be performed by trained personnel, familiar with the safety requirements and electronics.

Before opening the converter housing:

**DANGER!**

Make sure that all connecting cables are safely disconnected from all external sources.

**NOTE!**

*Make notes of important specific data, before exchanging the electronics.
Menu settings are stored on the circuit board (or backplane), that is fixed to the housing. After exchange of electronics unit and power-up, the following start up screen appears:
Load all data ?*



- Select yes
- ➔ - if in the screen appears **“load sensor data”**, the electronics units were not fully compatible. You can proceed by selecting yes. Note that all settings need to be checked and changed. Only the sensor calibration data are loaded.
- if in the screen appears **“load no data”**, all data have been lost. Contact your local Honeywell representative.

7.3.1 TWS 9000 F



DANGER!
Disconnect power!

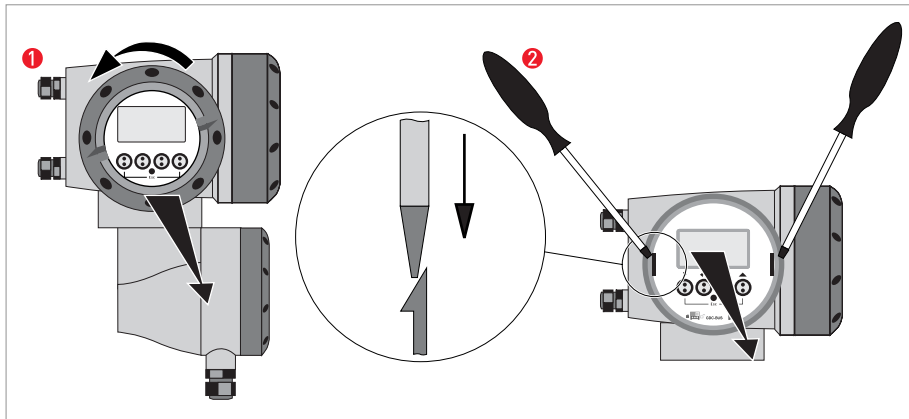


Figure 7-2: Unscrew the cover and remove the display

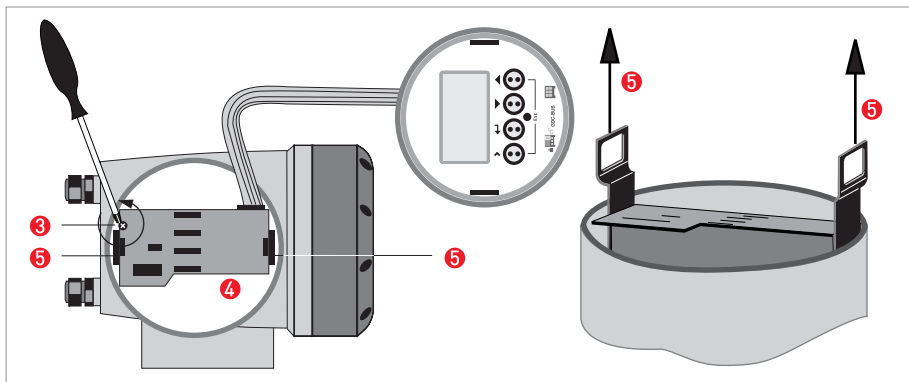


Figure 7-3: Pull off printed circuit board



Perform the following procedures:

- Unscrew the display cover of the electronics compartment by hand, by turning it counter clockwise ①.
- Remove the display by using two screwdrivers.
- Unscrew the two M4 screws ③ at the electronics unit ④.
- Pull the two metal pullers ⑤ at the left and right of the display, using a screwdriver or similar tool and partially pull out the electronics unit ②.



CAUTION!
Please pay attention that the same amount of force is applied on both pullers, otherwise the connector at the backside can be damaged.

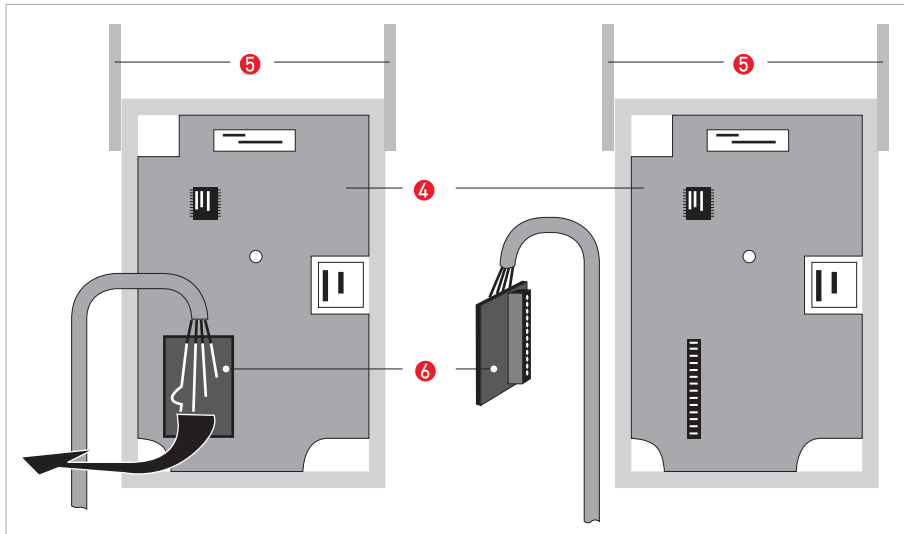


Figure 7-4: small printed circuit board and electronics unit



DANGER!

Electrostatic discharge (ESD) can damage electronic parts. Make sure to discharge yourself by wearing a wrist strap. If no wrist strap is available, ground yourself by touching a metal surface that is grounded.



- Remove the printed circuit board 6 from the electronics unit 4.
- Check compatibility between the removed and new electronics unit 4, by checking the power voltage.
- Slide the new electronics unit 4 partially back into the housing.
- Mount the small printed circuit board back onto the electronics unit 4.
- Push the metal pullers 5 back to their original position.
Don't use excessive force, otherwise the connector at the backside can be damaged!
- Screw the electronics unit back to the housing.
- Re-install the display and make sure not to kink the display's flat ribbon cable.
- Replace cover and tighten by hand.
- Connect power.

7.3.2 TWS 9000 W



DANGER!
Disconnect power!

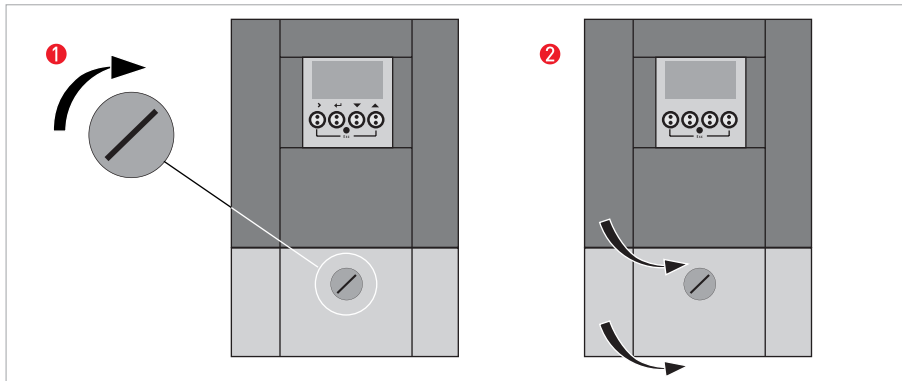


Figure 7-5: Unlock and open door



Perform the following procedures:

- Turn locking screw to the left **1** to unlock the lower door.
- Open lower door.
- Slide metal slider, positioned at the left upper angle, downwards.
- Open upper door **2**.

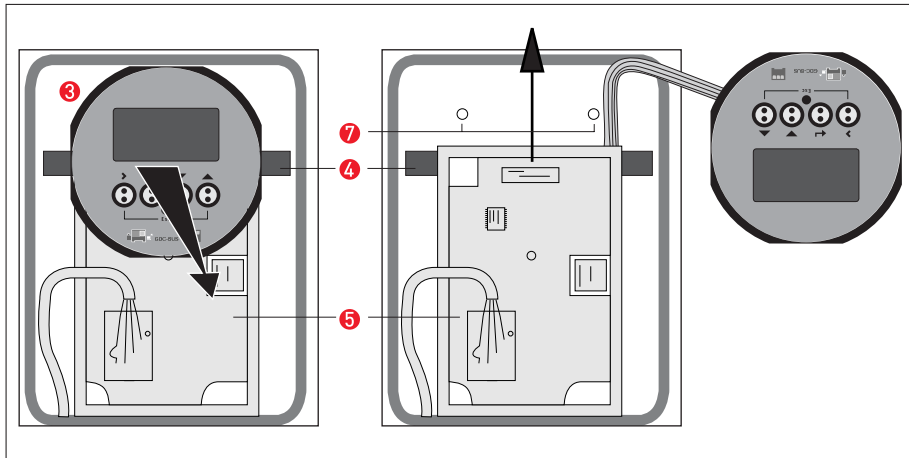


Figure 7-6: Remove the display



- Remove the display 3 by pressing the plastic holders on both sides 4 and carefully lay the display aside.
- Unscrew the two M4 screws 7 at the electronics unit 5.

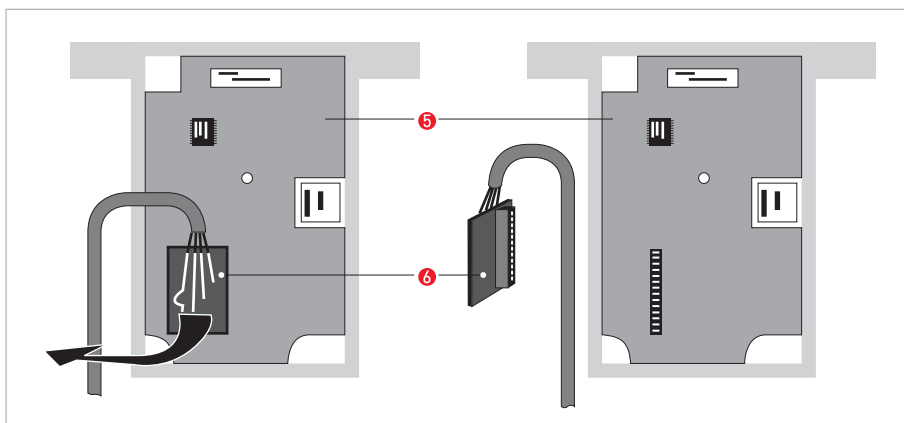


Figure 7-7: Release printed circuit board



- Remove the small printed circuit board 6 with care.
- Carefully slide the electronics unit 5, then lift it out of the housing.

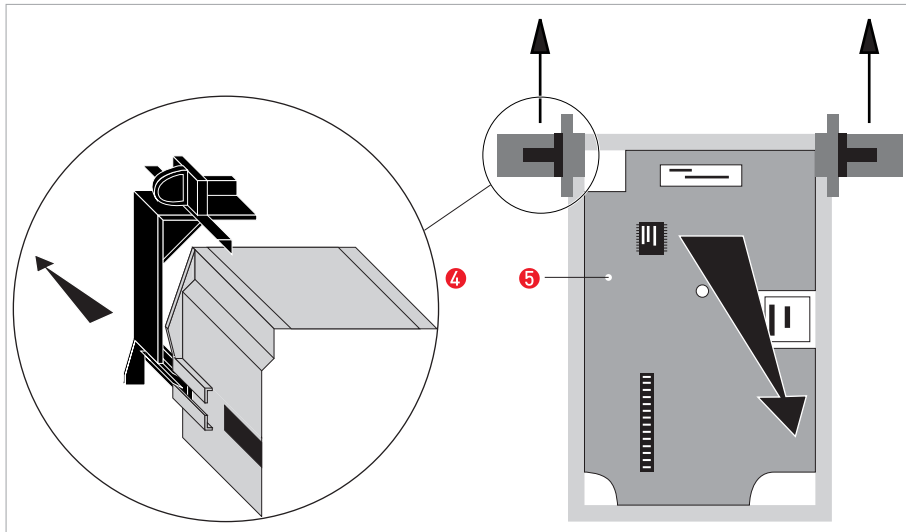


Figure 7-8: Remove holding brackets



- Remove the holding brackets **4** from the old electronics unit **5**.
- Check compatibility between the removed and new electronics unit, by checking the power voltage.
- Click the holding brackets **4** onto the new electronics unit and slide the new electronics unit into the housing.
- Mount the small printed circuit board back onto the sensor driver board.
- Screw the electronics unit back to the housing.
- Click the display back into the holders.
- Close and lock the upper door, slide the metal slider upwards.
- Close and lock the lower door.
- Connect power.



CAUTION!

First program the installation menu, refer to General instructions for programming on page 52 and check all important settings.

7.4 Replacing the mains fuse



CAUTION!

The following instructions shall always be carefully followed and only be performed by trained personnel, familiar with the safety requirements and electronics.

The mains fuse is in accordance with IEC 127-2. The size is diameter 5 x 20mm / 0.79" length.

Underneath codings for the mains fuse apply:

100...230VAC power supply: 0.8AT/H/250 , breaking capacity 1500A at 250V

24VAC/DC power supply: 2AT/H/250 , breaking capacity 1500A at 250V



DANGER!

Before opening the housing:

Make sure that all connecting cables are safely disconnected from all external sources.

7.4.1 TWS 9000 F



INFORMATION!

Please refer to TWS 9000 F on page 96 for details how to open the housing and remove / reinstall the electronics.

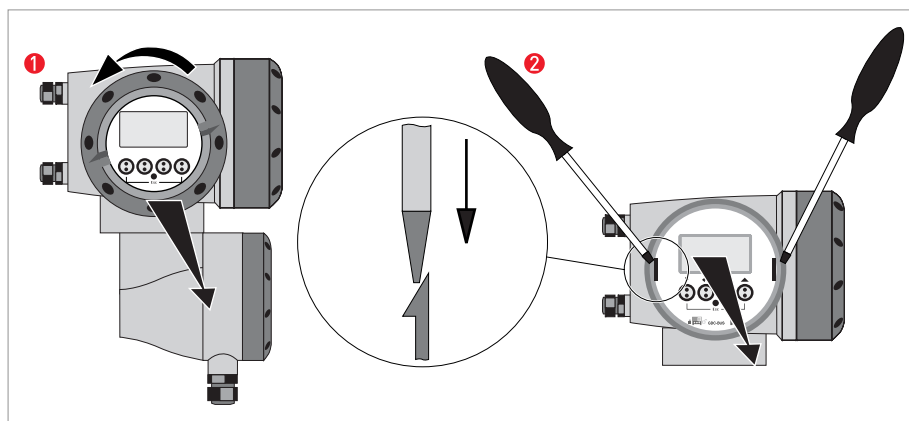


Figure 7-9: Unscrew the cover and remove the display



Once the electronic unit is removed,

- Replace the fuse. The fuse holder with the mains fuse is located on the power board, which is the upper board.
- Reinstall the electronics unit back to the housing.

- Reinstall cover and tighten down by hand ① and connect power.

7.4.2 TWS 9000 W



INFORMATION!

Please refer to TWS 9000 W on page 98 for details how to open the housing and remove the electronics.



Once the electronic unit is removed,

- Replace the fuse. The fuse holder with the mains fuse is located on the power board, which is at the back.
- Mount the small printed circuit board back onto the sensor driver board.
- Put the electronics unit back to the housing.
- Click the display back into the holders.
- Close the housing and lock the doors.
- Connect power.

7.5 Spare parts availability

It is the policy of the manufacturer to provide operational spare parts for any flowmeter or major accessory for a period of ten (10) years after shipment of the final production run of that flowmeter.

Operational spare parts are defined as those that are susceptible to failure during their normal operation.

7.6 Service availability

Manufacturer provides a variety of services to support its customers after warranty expiration. Repair, technical support and training can be provided.



NOTE!

For detailed information please contact your local representative.

7.7 Returning the device to the manufacturer

7.7.1 General information

This device has been carefully manufactured and tested. If installed and operated in accordance with these operating instructions, it will rarely present any problems.



CAUTION!

Should you nevertheless need to return a device for inspection or repair, please pay strict attention to the following points:

- *Due to statutory regulations on environmental protection and safeguarding the health and safety of our personnel, manufacturer may only handle, test and repair returned devices that have been in contact with products without risk to personnel and environment.*
- *This means that the manufacturer can only service this device if it is accompanied by the following certificate (see next section) confirming that the device is safe to handle.*



CAUTION!

If the device has been operated with toxic, caustic, flammable or water-endangering products, you are kindly requested:

- *to check and ensure, if necessary by rinsing or neutralizing, that all cavities are free from such dangerous substances,*
- *to enclose a certificate with the device confirming that is safe to handle and stating the product used.*

7.7.2 Form (for copying) to accompany a returned instrument

Company:		Address:	
Department:		Name:	
Tel. no.:		Fax no.:	
Manufacturer's order no. or serial no.:			
The device has been operated with the following medium:			
This medium is:	water-hazardous		
	toxic		
	caustic		
	flammable		
	We checked that all cavities in the device are free from such substances.		
	We have flushed out and neutralized all cavities in the device.		
We hereby confirm that there is no risk to persons or the environment through any residual media contained in the device when it is returned.			
Date:		Signature:	
Stamp:			

7.8 Disposal



CAUTION!

Disposal must be carried out in accordance with legislation applicable in your country.

8.1 Technical data

Ultrasonic flowmeter VersaFlow Sonic 1000 with TWS 9000

Versions

VersaFlow Sonic 1000 with TWS 9000	Standard
VersaFlow Sonic 1000 with TWS 9000 - Ex, zone 1/2	Option

Performance

Measurement functionality	Standard actual volume flow rate and totalised volume
Measuring range	0...20 m/s / 0...66 ft/s
Max. deviation (under reference conditions)	<± 1% of M.V. for DN ≥ 50 mm / 2", v > 0.5 m/s / 1.5 ft/s
	<± 3% of M.V. for DN < 50 mm / 2", v > 0.5 m/s / 1.5 ft/s
Repeatability	<± 0.2%
Process conditions	Solid particle content < 5% (by volume)
	Gas content < 2% (by volume)

Measurement configurations

Single path, single pipe or dual path/dual pipe	Standard
---	----------

Ultrasonic flow sensor VersaFlow Sonic 1000

Versions

VersaFlow Sonic 1000 - small (DN15...DN100 / ½"...4")	Standard
VersaFlow Sonic 1000 - medium (DN50...DN600 / 2...24")	Standard
VersaFlow Sonic 1000 - large (DN200...DN4000 / 8...160")	Standard
VersaFlow Sonic 1000 - small (ext. temp. DN15...DN100 / ½"...4")	Option
VersaFlow Sonic 1000- medium (ext. temp. DN50...DN600 / 2..24")	Option

Pipe specifications

Material: metal, plastic, ceramic, asbestos cement, internal/external coated pipes (coatings and liners fully bonded to pipe wall)	Standard
Maximum pipewall thickness of 200 mm / 7.87"	Standard

Protection category

IP67	Standard
------	----------

Electric signal level

Ex-I, intrinsically safe circuits, floating	Standard
---	----------

Process temperature

-40...120°C / -40...284°F	Standard
-50...200°C / -58...392°F, XT version	Option

Sensor cable length

5 m / 15 ft	Standard
10 m / 30 ft	Option
20 m / 60 ft	Option
30 m / 90 ft	Option

Recommended mounting area

Inlet	≥ 10DN
Outlet	≥ 5DN

Ultrasonic flow converter TWS 9000

Versions

W (wall)	TWS 9000 W (general purpose)
F (field)	TWS 9000 F (non-Ex)
F (/i-)Ex, zone 1/2	TWS 9000 F-Ex

Display languages

With local display	Standard
English, French, German	Standard

Flow sensor

VersaFlow Sonic 1000	DN15...4000 / ½" ... 160" ⓘ
----------------------	-----------------------------

Communication

Current, pulse & status output	Standard
HART® communication, control input	Standard

Power supply

100...230 VAC (-15/+10%), 50/60 Hz	Standard
24 VAC/DC	Option
Power consumption	22 VA

Approvals

EEx - zone 1/2	Option
FM - Class I DIV 1/2	Option
CSA - GP / Class I DIV 1/2	Option

Protection category

W (wall)	IP65 (eq. to NEMA 4/4X)
F (field)	IP66/67 (eq. to NEMA 6)

Temperature

Process	see flow sensor
Ambient	-40....60°C / -40....140°F
Storage	-50....70°C / -58....158°F

Cable connection

M20 x 1.5	Standard
½" NPT	Option
PF ½	Option

Materials used

Polyamide - polycarbonate (W-version)	Standard
Die-cast aluminium with polyurethane coating] (F-version)	Standard
Stainless steel 316 L / 1.4404 (F-version)	Option

Overall functionality

Highlights	Continuous measurement of actual volume flow rate, flow velocity, velocity of sound, damping of acoustic signal, signal to noise ratio
	Flow direction (forward or reverse)
	Totalisation of volume flow
	Reliability of flow measurement, Quality of acoustic signal

Current output

Function	All operating data configurable; galvanically isolated; HART® communication
Settings	
Q = 0%	0...15 mA
Q = 100%	10...22 mA
Error identification	0...22 mA
Connection Active:	
Basic/Modular IO	$I \leq 22 \text{ mA} / R_L \leq 1 \text{ kOhm}$
Ex-i I/O	$I \leq 22 \text{ mA} / R_L \leq 470 \text{ Ohm}$
	$U_o = 21 \text{ V} / I_o = 90 \text{ mA}$
	$P_o = 0.5 \text{ W}$
	$C_o = 90 \text{ nF} / L_o = 2 \text{ mH}$
Connection Passive:	
Basic/Modular IO	$I \leq 22 \text{ mA} / U \leq 32 \text{ VDC}$
Ex-i I/O	$I \leq 22 \text{ mA}$
	$U_i = 30 \text{ V} / I_i = 100 \text{ mA}$
	$P_i = 1 \text{ W}$
	$C_i = 10 \text{ nF} / L_i \sim 0 \text{ mH}$

Pulse output and status output

Function	Configurable as pulse output, identification for automatic range change, indicator of flow direction, overflow, errors, trip point or empty pipe indication
	Valve control, if batch control function is activated
Settings	
Q = 100%	0.0001... 10000 pulses/s or pulses/volume
Pulse width	0.1... 1000 ms or auto or sym.
Status	On or Off
Connection Active:	
Basic IO	On request
Ex-i I/O	On request
Connection Passive:	
Basic IO	$f \leq 10 \text{ kHz}; I \leq 20 \text{ mA}$
	$f \leq 10 \text{ Hz}; I \leq 100 \text{ mA}$
	$U \leq 32 \text{ VDC} / I \leq 100 \text{ mA}$
Ex-i I/O	Acc. EN 60947-5-6
	$U_i = 30\text{V} / I_i = 100 \text{ mA}$
	$P_i = 1 \text{ W}$
	$C_i = 10 \text{ nF} / L_i \sim 0 \text{ mH}$
Connection NAMUR:	
Basic IO	On request
Ex-i I/O	"Active"

Control input

Function	Freeze output (e.g. during cleaning), forced return to zero, counter and error reset, ext. range selection.
Settings	Freeze outputs, output zero, reset counter, reset error
Connection Active:	
Basic IO	$I_{nom} 16\text{mA} / U_{nom} 24\text{VDC}$
Ex-i I/O	Acc. EN 60947-5-6
Connection Passive:	
Basic IO	$U \leq 32 \text{ VDC}$
	$U_{on} > 19 \text{ VDC} / U_{off} < 2.5 \text{ VDC}$
Ex-i I/O	On request
Connection NAMUR:	
Basic IO	On request
Ex-i I/O	"Active"

① Outer diameter: 20...4300 mm / 0.79...169.29"

I/O Specifications

Overall functionality

Function	Continuous measurement of actual volume flow, mass flow, flow speed, velocity of sound, gain, SNR, diagnosis value
	Bidirectional flow measurement and totalisation
	Signal quality bar graph

Current output

Function	All operating data configurable; galvanically isolated; HART [®] communication
Settings	Q = 0%: 0...15mA
	Q = 100%: 10...22mA
	Error identification: 0...22mA
Connection	
Basic / Modular IO: Active	$I \leq 22\text{mA} / R_L \leq 1 \text{ k}\Omega$
Ex-i: Active	$I \leq 22\text{mA} / R_L \leq 470 \Omega$
	$U_0 = 21\text{V} / I_0 = 90\text{mA}$
	$P_0 = 0.5\text{W}$
	$C_0 = 90\text{nF} / L_0 = 2\text{mH}$
Basic / Modular IO: Passive	$I \leq 22\text{mA} / U \leq 32\text{VDC}$
Ex-i: Passive	$I \leq 22\text{mA}$
	$U_i = 30\text{V} / I_i = 100\text{mA}$
	$P_i = 1\text{W}$
	$C_i = 10\text{nF} / L_i \sim 0\text{mH}$

Pulse output and Status output

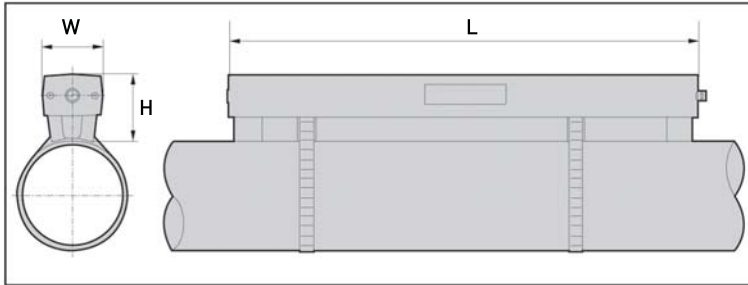
Function	Configurable as pulse output, identification for automatic range change, indicator of flow direction, overflow, errors, trip point or empty pipe indication
Settings	Q = 100%: 0.0001...10000 pulses per second or pulses per unit volume
	Pulse width: 0.05...2000ms or auto or sym.
	Status: On or Off
Connection	
Basic / Modular IO: Passive	$f \leq 10\text{kHz} / I \leq 20\text{mA}$
	$f \leq 10\text{Hz} / I \leq 100\text{mA}$
	$U \leq 32\text{VDC} / I \leq 100\text{mA}$
Passive	$U_i = 30\text{V} / I_i = 100\text{mA}$
	$P_i = 1\text{W}$
	$C_i = 10\text{nF} / L_i \sim 0\text{mH}$

Active	$U_{nom} = 24VDC / I < 1mA$
	$U_0 = 1.5V$ at 10mA
Namur (acc. to EN 60947-5-6)	Passive

Control input

Function	Freeze output (e.g. during cleaning), forced return to zero, counter and error reset, ext. range selection.
Settings	Freeze outputs, output zero, reset counter, reset error, start batch (in batch mode)
Connection	
Basic / Modular IO: Active	$I_{nom} = 16mA / U_{nom} = 24VDC$
Basic / Modular IO: Passive	$U \leq 32VDC$
	$U_{on} > 19VDC / U_{off} < 2.5VDC$
Namur (acc. to EN 60947-5-6)	Active

8.2 Dimensions and weights

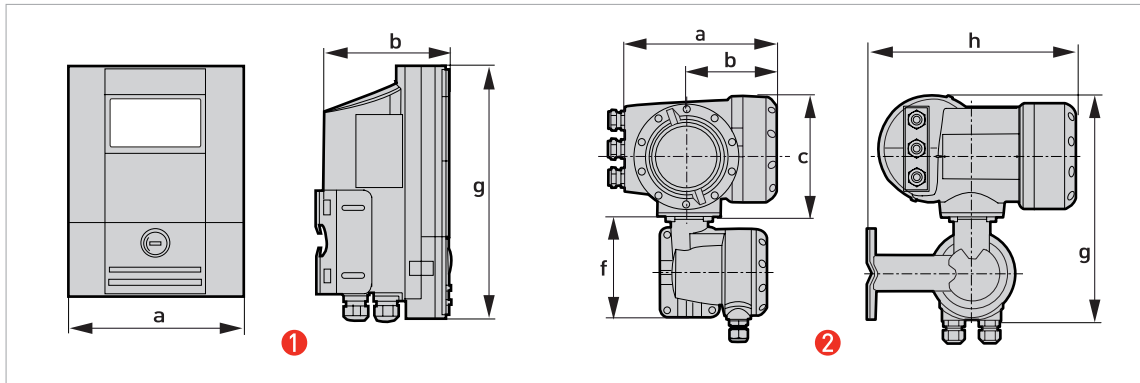


Version	Dimensions [mm]			Approx. weight (without cable / strip)
	L	H	W	[kg]
small	496.3	71	63.1	2.7
medium	826.3	71	63.1	3.6
large	496.3 ①	71 ①	63.1 ①	2.7 ①

① value for one of the 2 delivered rails

Version	Dimensions [inches]			Approx. weight (without cable / strip)
	L	H	W	[lbs]
small	19.5	2.8	2.5	6.0
medium	32.5	2.8	2.5	7.9
large	19.5 ①	2.8 ①	2.5 ①	6.0 ①

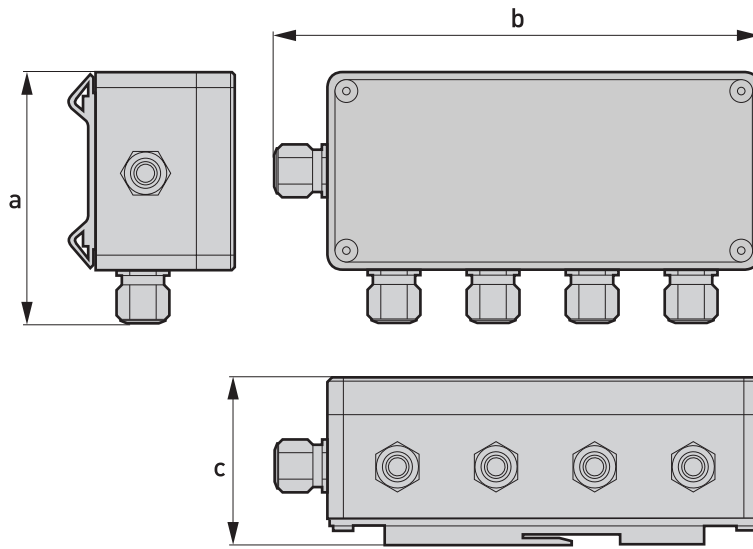
① value for one of the 2 delivered rails



- ❶ TWS 9000 W
- ❷ TWS 9000 F

Version	Dimensions [mm]						Weight [kg]
	a	b	c	f	g	h	
Wall	198	138	299	-	-	-	2.4
Field	202	120	155	141	296	277	5.7

Version	Dimensions [inches]						Weight [lbs]
	a	b	c	f	g	h	
Wall	7.8	5.4	11.8	-	-	-	5.3
Field	7.75	4.75	6.1	5.5	11.6	10.9	12.6



	Dimensions [mm]			Approx. weight without cable/metal [kg]
	a	b	c	
Cable box	102	197	67	0.85

	Dimensions [inches]			Approx. weight without cable/metal [lbs]
	a	b	c	
Cable box	4.01	7.76	2.64	1.87



Honeywell

AUTHORIZED DISTRIBUTOR

De Gidts & Feldman BV
The Netherlands
www.dgfg.nl



De Gidts & Feldman

INSTRUMENTATION & FILTRATION

Honeywell Field Solutions
512 Virginia Drive
Fort Washington, PA 19034
www.honeywell.com/ps