

## **DR4500A Truline Circular Chart Recorder With or Without Control Product Manual**

Doc. No.:	44-45-25-30
Release:	L
Last Revision Date:	8/02

# Notices and Trademarks

Copyright 2002 by Honeywell  
Release L - August, 2002

## WARRANTY/REMEDY

Honeywell warrants goods of its manufacture as being free of defective materials and faulty workmanship. Contact your local sales office for warranty information. If warranted goods are returned to Honeywell during the period of coverage, Honeywell will repair or replace without charge those items it finds defective. The foregoing is Buyer's sole remedy and is in lieu of all other warranties, expressed or implied, including those of merchantability and fitness for a particular purpose. Specifications may change without notice. The information we supply is believed to be accurate and reliable as of this printing. However, we assume no responsibility for its use.

While we provide application assistance personally, through our literature and the Honeywell web site, it is up to the customer to determine the suitability of the product in the application.

## Industrial Measurement and Control

Honeywell  
1100 Virginia Drive  
Ft. Washington, PA 19034

DR4500 Truline is a U.S. registered trademark of Honeywell.

Other brand or product names are trademarks of their respective owners.

---

# About This Document

## References

The following list identifies all documents that may be sources of reference for material discussed in this publication.

Document Title	Doc ID
How to Apply Digital Instrumentation in Severe Electrical Noise Environments	51-52-05-01
Modbus® RTU Serial Communications User Manual	51-52-25-66
Modbus® RTU Serial Communications User Manual Configuration Interface for DR4500	51-52-25-69

## Contacts

### World Wide Web

The following lists Honeywell's World Wide Web sites that will be of interest to our customers.

Honeywell Organization	WWW Address (URL)
Corporate	<a href="http://www.honeywell.com">http://www.honeywell.com</a>
Industrial Measurement and Control	<a href="http://www.honeywell.com/imc/">http://www.honeywell.com/imc/</a>

### Telephone







Contact us by telephone at the numbers listed below.

Organization	Phone Number
United States and Canada      Honeywell	1-800-423-9883      Tech. Support
	1-888-423-9883      Q&A Faxback (TACFACS)
	1-800-525-7439      Service

---

## Symbol Definitions

The following table lists those symbols used in this document to denote certain conditions.

Symbol	Definition
	This CAUTION symbol on the equipment refers the user to the Product Manual for additional information. This symbol appears next to required information in the manual.
	WARNING: risk of electrical shock. This symbol warns the user of a potential shock hazard where HAZARDOUS LIVE voltages greater than 30 Vrms, 42.4 Vpeak, or 60 VDC may be accessible.
	ATTENTION, Electrostatic Discharge (ESD) hazards. Observe precautions for handling electrostatic sensitive devices
	Protective Earth (PE) terminal. Provided for connection of the protective earth (green or green/yellow) supply system conductor.
	Functional earth terminal. Used for non-safety purposes such as noise immunity improvement. NOTE: This connection shall be bonded to protective earth at the source of supply in accordance with national local electrical code requirements.
	Earth Ground. Functional earth connection. NOTE: This connection shall be bonded to Protective earth at the source of supply in accordance with national and local electrical code requirements.
	Chassis Ground. Identifies a connection to the chassis or frame of the equipment shall be bonded to Protective Earth at the source of supply in accordance with national and local electrical code requirements.

---

# Contents

1. Overview .....	1
1.1 Introduction .....	1
1.2 Operator Interface.....	3
1.3 Set-up Tasks.....	5
2. Installation .....	7
2.1 Overview.....	7
2.2 Model Number Interpretation.....	13
2.3 Mounting Considerations and Overall Dimensions .....	16
2.4 Mounting Methods .....	17
2.5 Wiring Prerequisites.....	27
2.6 Input Wiring Procedures .....	29
2.7 Output Wiring Procedures .....	39
2.8 Option Wiring Procedures .....	45
2.9 Lockout Switch Configuration .....	54
3. Configuration .....	55
3.1 Overview.....	55
3.2 Configuration Prompts.....	57
3.3 How To Get Started .....	60
3.4 Configuration Tips.....	61
3.5 Configuration Procedure.....	62
3.6 Input Set Up Group.....	64
3.7 Pen Set Up Group .....	66
3.8 Chart Set Up Group.....	67
3.9 Time Set Up Group.....	69
3.10 Totalizer Set Up Group.....	70
3.11 Input Algorithm Set Up Group .....	72
3.12 Control Set Up Group .....	73
3.13 Tuning Parameters Set Up Group .....	75
3.14 SP Ramp Set Up Groups .....	76

---

3.15	Timer Set Up Group .....	77
3.16	Alarms Set Up Group .....	78
3.17	Auxiliary Output Set Up Group .....	80
3.18	Modbus Communications Set Up Group .....	81
3.19	Options Set Up Group .....	82
3.20	Event Message Configuration .....	83
3.21	Lockout Set Up Group .....	86
3.22	Adjust Printing.....	87
3.23	Configuration Record Sheet .....	88
<b>4.</b>	<b>Configuration Parameter Definitions.....</b>	<b>93</b>
4.1	Overview.....	93
4.2	Input Parameters Set Up Group.....	94
4.3	Pen Parameters Set Up Group.....	98
4.4	Chart Parameters Set Up Group .....	100
4.5	Time Parameters Set Up Group.....	103
4.6	Total Parameters Set Up Group.....	104
4.7	Input Algorithm Set Up Group .....	106
4.8	Control Parameters Set Up Group .....	109
4.9	Tuning Parameters Set Up Group.....	119
4.10	Setpoint Ramp Set Up Group.....	122
4.11	Timer Set Up Group .....	124
4.12	Alarms Set Up Group .....	125
4.13	Auxiliary Output Set Up Group .....	128
4.14	Modbus Communications Set Up Group.....	130
4.15	Options Set Up Group .....	131
4.16	Event Message Set Up Group.....	133
4.17	Lockout Parameters Set Up Group .....	134
4.18	Printing Characteristics Adjustments.....	135
<b>5.</b>	<b>Operation .....</b>	<b>137</b>
5.1	Overview.....	137
5.2	Start-up.....	138
5.3	Monitoring Your Recorder .....	142
5.4	Operator Functions.....	148
5.5	Operating Modes .....	149
5.6	Setpoints.....	151

---

5.7	Single Setpoint Ramp .....	153
5.8	Using Two Sets of Tuning Constants (PID Values).....	156
5.9	Using Accutune II.....	159
5.10	Alarm Setpoints .....	162
5.11	Three Position Step Control Algorithm .....	163
5.12	Digital Input Option (Remote Switching).....	164
5.13	Resetting and Displaying Totalizer Value.....	165
5.14	Monitoring the External Event Operation .....	167
5.15	Maximizing Pen Life.....	168
5.16	Routine Maintenance.....	169
5.17	Installing/Replacing Chart.....	170
5.18	Chart Operation .....	171
<b>6.</b>	<b>Setpoint Ramp/Soak Programming and Operation .....</b>	<b>173</b>
6.1	Overview.....	173
6.2	Setpoint Program Contents .....	175
6.3	Drawing a Ramp/Soak Profile .....	178
6.4	Entering the Setpoint Program Data.....	183
6.5	SP RAMP1 and SP RAMP2 Set Up Group .....	185
6.6	Setpoint Program Profiles Set Up Group .....	187
6.7	Setpoint Program Segments Set Up Group .....	189
6.8	Setpoint Program Event Set Up Group .....	192
6.9	Run/Monitor the Program .....	196
<b>7.</b>	<b>Input Calibration .....</b>	<b>199</b>
7.1	Overview.....	199
7.2	Restoring Factory Calibration .....	200
7.3	Minimum and Maximum Range Values.....	202
7.4	Preliminary Information.....	203
7.5	Calibration Set Up and Wiring for PV Inputs .....	205
7.6	Calibration Procedure.....	214
7.7	Printing Characteristics Adjustments.....	217
<b>8.</b>	<b>Output Calibration .....</b>	<b>219</b>
8.1	Overview.....	219
8.2	Current Proportional Output/Aux Out 2 and 3 Calibration .....	220
8.3	Position Proportional and Three Position Step Output Calibration .....	222

---

8.4	Auxiliary Output Calibration .....	225
<b>9.</b>	<b>Troubleshooting / Service .....</b>	<b>227</b>
9.1	Overview .....	227
9.2	Troubleshooting Aids .....	229
9.3	Self Diagnostics .....	231
9.4	Visual Failure Symptoms .....	237
9.5	Troubleshooting Procedures .....	238
<b>10.</b>	<b>Parts List .....</b>	<b>245</b>
10.1	Overview .....	245
10.2	Exploded Views .....	246
10.3	Miscellaneous Hardware Kit Contents .....	252
10.4	Internal Cabling Data .....	253
10.5	Internal Wiring Diagram – Options Only .....	254
<b>A.</b>	<b>Model DR45AR .....</b>	<b>255</b>
A.1	Overview .....	255
A.2	Hardware Identification .....	256
A.3	Fo Reset Configuration .....	258
A.4	Options Configuration .....	259
A.5	Operations Additions .....	261
A.6	Configuration Worksheet Additions .....	262
<b>B.</b>	<b>Security Lockout .....</b>	<b>263</b>
B.1	Overview .....	263
<b>C.</b>	<b>Foreign Language Safety Instructions .....</b>	<b>265</b>
	DA2I-6056 .....	266
	DU2I-6056 .....	267
	FI2I-6056 .....	268
	FR2I-6056 .....	269
	GE2I-6056 .....	270
	GR2I-6056 .....	271
	IT2I-6056 .....	272
	NO2I-6056 .....	273
	PO2I-6056 .....	274



---

SP2I-6056.....	275
SW2I-6056.....	276
<b>Index .....</b>	<b>277</b>

---

## Tables

Table 1-1	Function of Keys .....	4
Table 2-1	Operating Limits and Condensed Specifications.....	8
Table 2-2	Procedure to Access Components .....	14
Table 2-3	Mounting Flush in a New Panel Cutout .....	18
Table 2-4	Reference Data for Mounting DR4500A in Existing Panel Cutouts .....	19
Table 2-5	Mounting Flush in a Panel Using Universal Filler Kit.....	20
Table 2-6	Mounting Flush in a Panel Using Kent Model 105M Cutout.....	21
Table 2-7	Procedure for Mounting Recorder with Heavy Duty Door .....	22
Table 2-8	Pipe Mounting Procedure.....	24
Table 2-9	Mounting Flush on a Surface (of Panel or Wall).....	25
Table 2-10	Permissible Wiring Bundling .....	28
Table 2-11	AC Line Power Wiring.....	31
Table 2-12	Thermocouple, RTD, Radiamatic, mV, or 0–5 Vdc Input Wiring .....	33
Table 2-13	4-20 mA Input Wiring.....	35
Table 2-14	0-10 Volt dc Input Wiring .....	37
Table 2-15	4-20 mA Control Output Wiring .....	39
Table 2-16	Position Proportional Control Output Wiring .....	41
Table 2-17	Relay Control Output Wiring .....	43
Table 2-18	Alarm Output or Digital Input Wiring.....	45
Table 2-19	Alarm 3 and Alarm 4 Output Wiring .....	47
Table 2-20	Alarm 5 and Alarm 6 Output Wiring .....	48
Table 2-21	RS485 Modbus Communications Wiring.....	50
Table 2-22	4-20 mA Auxiliary Output Wiring.....	52
Table 3-1	Configuration Tips .....	61
Table 3-2	Configuration Procedure .....	62
Table 3-3	Input Group Function Prompts.....	64
Table 3-4	Pen 1, 2, 3, 4 Group Function Prompts .....	66
Table 3-5	Chart Group Function Prompts .....	67
Table 3-6	Time Group Function Prompts.....	69
Table 3-7	Totalizer Group Function Prompts.....	70
Table 3-8	Input Algorithm Group Function Prompts .....	72
Table 3-9	Control 1 or Control 2 Group Function Prompts.....	73
Table 3-10	Tuning 1 or Tuning 2 Group Function Prompts.....	75
Table 3-11	SP Ramp 1 or 2 Group Function Prompts .....	76
Table 3-12	Timer Group Function Prompts.....	77
Table 3-13	Priority of functions that operate relays .....	78
Table 3-14	Alarms Group Function Prompts.....	79
Table 3-15	Auxiliary Output Group Function Prompts .....	80
Table 3-16	Modbus Communications Group Function Prompts .....	81
Table 3-17	Options Group Function Prompts.....	82
Table 3-18	Event Message Group Function Prompts .....	83
Table 3-19	Lockout Group Function Prompts .....	86
Table 3-20	Adjust Group Function Prompts.....	87
Table 4-1	Input Group Definitions .....	94
Table 4-2	Pen 1, 2, 3, or 4 Group Definitions.....	98
Table 4-3	Chart Parameters Group Definitions .....	100
Table 4-4	Time Parameters Group Definitions.....	103
Table 4-5	Totalizer Group Definitions .....	104
Table 4-6	Input Algorithm Group Definitions.....	106
Table 4-7	Control 1 or 2 Group Definitions .....	109
Table 4-8	Tuning Group Prompt Definitions.....	119
Table 4-9	Setpoint Ramp 1 or 2 Group Definitions.....	122
Table 4-10	Timer Group Definitions.....	124

---

Table 4-11	Priority of functions that operate relays .....	125
Table 4-12	Alarms Group Definitions .....	126
Table 4-13	Auxiliary Output Group Definitions .....	128
Table 4-14	Modbus Communications Group Definitions.....	130
Table 4-15	Option Group Definitions.....	131
Table 4-16	Event Message Group Definitions.....	133
Table 4-17	Lockout Group Definitions .....	134
Table 4-18	Printing Characteristics Adjustment Procedure.....	136
Table 5-1	Power Up Diagnostic Tests .....	138
Table 5-2	Procedure for Testing the Displays and Keys .....	139
Table 5-3	Procedure for Starting Up the Recorder .....	140
Table 5-4	Meaning of Indicators .....	143
Table 5-5	Lower Display Key Parameter Prompts .....	145
Table 5-6	Error Messages.....	146
Table 5-7	Alarm and tuning messages.....	147
Table 5-8	Operating Mode Definitions.....	149
Table 5-9	Changing Operating Modes.....	149
Table 5-10	Procedure for Selecting Automatic or Manual Mode.....	150
Table 5-11	Procedure for Selecting the Setpoint Source .....	151
Table 5-12	Procedure for Changing the Local Setpoint .....	151
Table 5-13	Procedure for Switching Between Setpoints .....	152
Table 5-14	Setpoint Selection Indication.....	152
Table 5-15	Procedure for Configuring a Single Setpoint Ramp.....	153
Table 5-16	Procedure for Running a Setpoint Ramp.....	154
Table 5-17	Procedure for Selecting Two Sets of Tuning Constants .....	156
Table 5-18	Procedure for Setting Switchover Values.....	157
Table 5-19	Procedure for Setting Tuning Constant Values .....	157
Table 5-20	Procedure for Switching PID Sets from the Keyboard.....	158
Table 5-21	Procedure for Starting Accutune II.....	159
Table 5-22	Procedure for Using Accutune for Duplex Control.....	160
Table 5-23	Procedure for Displaying or Changing the Alarm Setpoints .....	162
Table 5-24	Procedure for Displaying the 3PSTEP Motor Position .....	163
Table 5-25	Digital Input Option Action on Contact Closure.....	164
Table 5-26	Procedure for Resetting the Totalizer .....	165
Table 5-27	Procedure for Displaying the Totalizer Value .....	166
Table 5-28	Maximizing Pen Life.....	168
Table 5-29	Cleaning the Pen Tip .....	169
Table 5-30	Replacing a Chart Lamp.....	169
Table 5-31	Installing/Replacing the Chart.....	170
Table 5-32	Remote Chart Modes.....	172
Table 6-1	Parameter settings for example 12-step profile .....	179
Table 6-2	Setpoint program data entry procedure .....	183
Table 6-3	SP RAMP prompts and available selections .....	185
Table 6-4	Setpoint Program Profiles Group Definitions .....	187
Table 6-5	Setpoint Program Segments Group Definitions .....	189
Table 6-6	Setpoint Program Event Group Definitions.....	192
Table 6-7	Segment Event relay operation requirements.....	193
Table 6-8	Run/Monitor Functions .....	196
Table 7-1	Restoring Factory Calibration .....	200
Table 7-2	Voltage and Resistance Equivalents for 0 % and 100 % Range Values.....	202
Table 7-3	Disconnect the Field Wiring.....	203
Table 7-4	Equipment Needed .....	204
Table 7-5	General Set Up Procedure .....	206
Table 7-6	Set Up Wiring Procedure for Thermocouple Inputs Using an Ice Bath .....	207
Table 7-7	Set Up Wiring Procedure for Thermocouple Inputs Using a Compensated Calibrator Method.....	208

---

Table 7-8	Set Up Wiring Procedure for Thermocouple Inputs Using the Ambient Temperature Method .....	209
Table 7-9	Set Up Wiring Procedure for RTD Inputs .....	210
Table 7-10	Set Up Wiring Procedure for Radiamatic, Millivolts, and Volts Inputs (except 0-10 Volts) .....	211
Table 7-11	Set Up Wiring Procedure for 0–10 Volt Inputs .....	212
Table 7-12	Set Up Wiring Procedure for 4–20 mA Inputs .....	213
Table 7-13	Calibration Procedure Sequence .....	214
Table 8-1	Set Up Wiring Procedure Current Proportional Output/Aux Out 2 and 3 .....	220
Table 8-2	Current Proportional Output/Aux Output 2 and 3 Calibration Procedure .....	221
Table 8-3	Position Proportional and 3 Position Step Output Calibration Procedure .....	223
Table 8-4	Set Up Wiring Procedure Auxiliary Output .....	225
Table 8-5	Auxiliary Output Calibration Procedure .....	226
Table 9-1	Identifying the software version .....	230
Table 9-2	Power-up tests .....	231
Table 9-3	Displaying the test results .....	232
Table 9-4	Error message prompts .....	233
Table 9-5	Visual failure symptoms .....	237
Table 9-6	Procedure #1—Troubleshooting recorder failure symptoms .....	238
Table 9-7	Procedure #2—Troubleshooting pen trace failure symptoms .....	239
Table 9-8	Procedure #3—Troubleshooting chart rotation failure symptoms .....	239
Table 9-9	Procedure #4—Troubleshooting chart rotation failure symptoms .....	240
Table 9-10	Procedure #5—Troubleshooting pen failure symptoms .....	240
Table 9-11	Procedure #6—Troubleshooting keyboard and/or display failure symptoms .....	240
Table 9-12	Procedure #7—Troubleshooting current proportional output failure symptoms .....	241
Table 9-13	Procedure #8—Troubleshooting position proportional output failure symptoms .....	241
Table 9-14	Procedure #9—Troubleshooting relay output failure symptoms .....	242
Table 9-15	Procedure #10—Troubleshooting current/time or time/current failure symptoms .....	242
Table 9-16	Procedure #11—Troubleshooting the auxiliary output .....	243
Table 9-17	Procedure #12—Troubleshooting external alarm function failure symptoms .....	243
Table 9-18	Procedure #13—Troubleshooting Modbus communications .....	243
Table 10-1	Door assembly parts .....	246
Table 10-2	Chart plate assembly parts .....	247
Table 10-3	Basic recorder parts without options .....	249
Table 10-4	Recorder parts associated with options .....	251
Table 10-5	Miscellaneous hardware kit .....	252
Table A-1	Fo RESET group function prompts .....	258
Table A-2	Options group function prompts, continued from Section 3/Table 3-17 .....	259
Table A-3	Option group definitions, continued from Section 4/Table 4-15 .....	260

---

# Figures

Figure 1-1	Operator Interface .....	3
Figure 1-2	Set-up Tasks .....	5
Figure 2-1	Model Number Interpretation .....	13
Figure 2-2	DR4500A Recorder Hardware Components Versus “Table” Selections .....	15
Figure 2-3	Overall Dimensions .....	16
Figure 2-4	How to Remove Knockouts .....	17
Figure 2-5	Mounting Flush in a New Panel Cutout .....	18
Figure 2-6	Mounting in a Panel Using Universal Filler Kit .....	20
Figure 2-7	Mounting in a Panel using Kent Model 105M Cutout .....	21
Figure 2-8	Panel Mounting Recorder with Heavy Duty Door .....	23
Figure 2-9	Pipe Mounting Brackets .....	24
Figure 2-10	Mounting Flush on a Surface (of Panel or Wall) .....	26
Figure 2-11	Ferrite Filter Locations and Shield Wiring (CE Mark) .....	30
Figure 2-12	AC Line Power Wiring .....	32
Figure 2-13	Thermocouple, RTD, Radiamatic, mV, or 0–5 Vdc Input Wiring .....	34
Figure 2-14	4-20 mA Input Wiring .....	36
Figure 2-15	0-10 Volt dc Input Wiring .....	38
Figure 2-16	4-20 mA Control Output Wiring (or Aux Out #2 and #3 Wiring) .....	40
Figure 2-17	Position Proportional Control Output or Three Position Step Wiring .....	42
Figure 2-18	Relay Control Output Wiring .....	44
Figure 2-19	Alarm Output or Digital Input Wiring .....	46
Figure 2-20	Alarm outputs #3, 4, 5, and 6 wiring .....	49
Figure 2-21	RS485 Modbus Communications Wiring .....	51
Figure 2-22	4-20 mA Auxiliary Output #1 Wiring .....	53
Figure 2-23	S1 Lockout Switch Location .....	54
Figure 3-1	DR4500A Prompt Hierarchy .....	57
Figure 5-1	Operator Interface .....	142
Figure 5-2	Deviation Bargraph .....	144
Figure 6-1	Ramp/Soak Profile Example .....	178
Figure 7-1	Location of the Input Connections on the Input Boards .....	203
Figure 7-2	Location of Jumper Positions W1/MA and W3 on the Input Boards .....	205
Figure 7-3	Calibration Set Up Diagram for Thermocouple Inputs Using an Ice Bath .....	207
Figure 7-4	Calibration Set Up Diagram for Thermocouple Inputs Using a Compensated Calibrator Method .....	208
Figure 7-5	Calibration Set Up Diagram for Thermocouple Inputs using the Ambient Temperature Method .....	209
Figure 7-6	Calibration Set Up Diagram for RTD Inputs .....	210
Figure 7-7	Calibration Set Up Diagram for Radiamatic, Millivolts, and Volts Inputs (except 0-10 Volts) .....	211
Figure 7-8	Calibration Set Up Diagram for 0–10 Volt Inputs .....	212
Figure 7-9	Calibration Set Up Diagram for 4–20 mA Inputs .....	213
Figure 8-1	Test Equipment Connections for Calibrating Current Proportional Output .....	220
Figure 8-2	Test Equipment Connections for Calibrating Auxiliary Output .....	225
Figure 10-1	Door assembly .....	246
Figure 10-2	Chart plate assembly .....	247
Figure 10-3	Basic recorder components without options .....	248
Figure 10-4	Recorder components associated with options .....	250
Figure 10-5	Internal cabling for DR4500A Truline recorder .....	253
Figure 10-6	Internal diagram for DR4500A Truline recorder – options only .....	254
Figure A-1	DR45AR with one input .....	256
Figure A-2	DR45AR with two to four inputs .....	257



# 1. Overview

## 1.1 Introduction

### Function

The DR4500A Truline Recorder is a one to four-channel microprocessor-based circular chart recorder. Its "one-pen" stylus printhead produces up to four analog traces and prints alphanumeric chart data on a blank heat-sensitive chart. All four traces share the same time line reference which the Truline prints. This eliminates the error caused by pen alignment offsets in conventional pen designs. Since the Truline prints the chart and generates the analog traces at the same time, there is no error due to variations in chart size caused by changes in temperature and humidity.

In addition to printing chart records, the Truline recorder alternately displays process variable values for all channels in the selected engineering units.

Models with up to four input channels accept inputs from any one of a variety of sensors or transmitters within the configurable range limits.

The Truline is also available with one or two independent digital controllers and setpoint programmers.

### CE Conformity (Europe)

Indicated models of this product are in conformity with the protection requirements of the following European Council Directives: **73/23/EEC**, the Low Voltage Directive, and **89/336/EEC**, the EMC Directive. Conformity of this product with any other "CE Mark" Directive(s) shall not be assumed.

Deviation from the installation conditions specified in this manual, and the special conditions for CE conformity in Subsection 2.1, may invalidate this product's conformity with the Low Voltage and EMC Directives.



#### ATTENTION

The emission limits of EN 61326 are designed to provide reasonable protection against harmful interference when this equipment is operated in an industrial environment. Operation of this equipment in a residential area may cause harmful interference. This equipment generates, uses, and can radiate radio frequency energy and may cause interference to radio and television reception when the equipment is used closer than 30 meters (98 feet) to the antenna(e). In special cases, when highly susceptible apparatus is used in close proximity, the user may have to employ additional mitigating measures to further reduce the electromagnetic emissions of this equipment.

---

### Microprocessor controlled recording and printing

Both the chart and printhead are driven by stepper motors controlled by the microprocessor with configurable chart speed through the keypad.

You can configure various "printed" chart data such as range marking in engineering units, digital values for process variables, and trace identification. This data plus printed time lines and engineering units of scale eliminate the need to maintain an inventory of a variety of preprinted charts.

The Truline recorder uses a dot fill technique from a microprocessor algorithm to produce a continuous analog trace of a process variable.

## Digital controller

The DR4500A recorder controller includes an integral microprocessor-based, single or dual loop PID controller with optional setpoint program. A variety of output types, including a duplex variation for heat cool applications, lets you select the output that is right for your final control element. Accutune II lets you automatically tune your loops.

You can configure the control action as On-Off, PID-A, PID-B, PD with manual reset, or Three Position Step. English language prompts guide you through the entry of all the controller's configurable parameters.

## Construction

The DR4500A recorder is housed in a molded case which can be panel or surface mounted. A glass or acrylic windowed door (A UL and FM approved NEMA4X door is also available )protects the internal components while allowing easy access to the chart and operator interface. An optional external keypad that allows operator selections without opening the door is available.

Circuitry is partitioned on printed circuit boards for ease of service.

Power, input, and output wiring connect to terminations inside the case. Knockouts in the sides and bottom of the case accept conduit connections for convenient wire entry.



## 1.2 Operator Interface

### Operator interface

Figure 1-1 shows the operator interface and defines the displays and indicators. The function of the keys is described in Table 1-1.

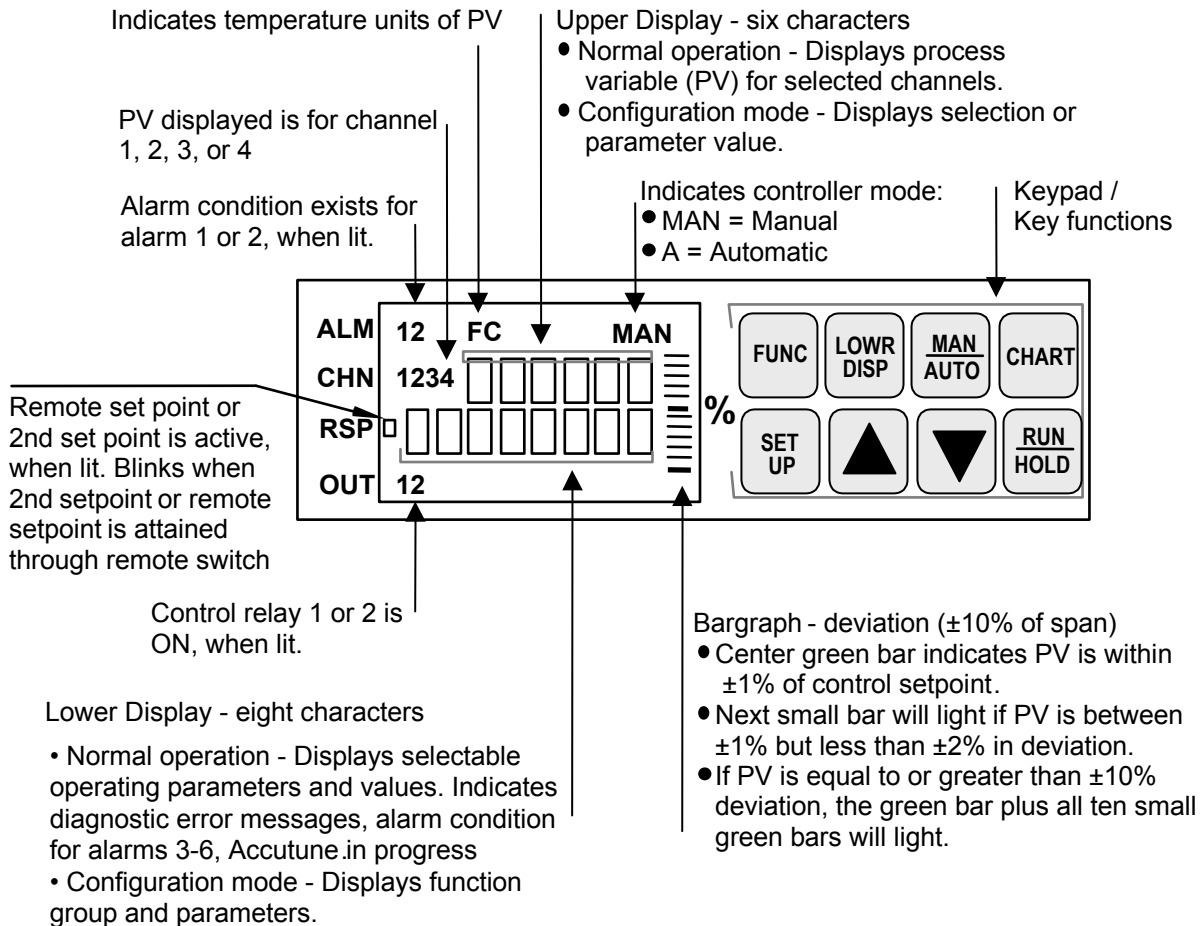

Figure 1-1 Operator Interface

## Key functions

Table 1-1 shows each key on the operator interface and defines its function.

**Table 1-1 Function of Keys**

Key	Function
<b>SET UP</b>	<ul style="list-style-type: none"> <li>Places the controller in the Configuration Set Up group select mode. Sequentially displays Set Up groups and allows the <b>FUNC</b> key to display individual functions in each Set Up group.</li> </ul>
<b>FUNC</b>	<ul style="list-style-type: none"> <li>Used in conjunction with the <b>SET UP</b> key to select the individual functions of a selected Configuration Set Up group.</li> <li>Used to toggle between SP1 and SP2.</li> <li>Used during field calibration procedure.</li> </ul>
<b>LOWR DISP</b>	<ul style="list-style-type: none"> <li>Selects an operating parameter to be shown in the lower display: <ul style="list-style-type: none"> <li>OUT = Output Value (estimated motor position for 3 Position Step)</li> <li>SP = Local Setpoint 1</li> <li>SPN = Current setpoint for setpoint rate applications</li> <li>2SP = Local Setpoint 2</li> <li>RSP = Remote Setpoint</li> <li>1IN = Input 1 (if Loop 1 is a derived PV)</li> <li>2IN = Input 2</li> <li>3IN = Input 3</li> <li>4IN = Input 4</li> <li>DEV = Deviation</li> <li>EU = PV Engineering Units</li> <li>RH = % RH Value</li> <li>PIDSETX = Tuning Parameter Set X=1 or 2</li> <li>RAMP = Minutes remaining in Setpoint Ramp</li> <li>#RA = Minutes remaining in SP Prog Ramp</li> <li>#SK = Minutes remaining in SP Prog Soak</li> <li>RECYC = Number of recycles left in SP Program</li> <li> □.□□ = Time remaining in Timer function</li> <li> □.□□ = Time elapsed in Timer function</li> <li>TUNExXXX = Accutune II indicator. x = 1 or 2</li> </ul> </li> </ul> <p><b>ATTENTION</b> The lower display can be configured to scroll through the operating parameters.</p>
<b>MAN AUTO</b>	<ul style="list-style-type: none"> <li>Alternately selects: <ul style="list-style-type: none"> <li>AUTO Lower display automatically displays setpoint value in engineering units.</li> <li>MAN Lower display automatically indicates output in %.</li> </ul> </li> </ul>
<b>CHART</b>	<ul style="list-style-type: none"> <li>Used to stop printing operation and move pen to outer limit for chart change. Display will revert to date and time.</li> </ul>
<b>RUN HOLD</b>	<ul style="list-style-type: none"> <li>Alternate action switch initiates or holds the Setpoint Ramp or Setpoint Program.</li> <li>In configuration mode, restores the original value or selection if you do not want to enter a change you are making to a parameter.</li> </ul>
<b>▲</b>	<ul style="list-style-type: none"> <li>Increases the setpoint, output, or configuration values displayed.</li> </ul>
<b>▼</b>	<ul style="list-style-type: none"> <li>Decreases the setpoint, output, or configuration values displayed.</li> </ul>

## 1.3 Set-up Tasks

### Major set-up tasks

As shown in Figure 1-2, there are four major tasks that you must complete to "Set Up" the DR4500A recorder for operation. For easy reference the section numbers for each task are shown.

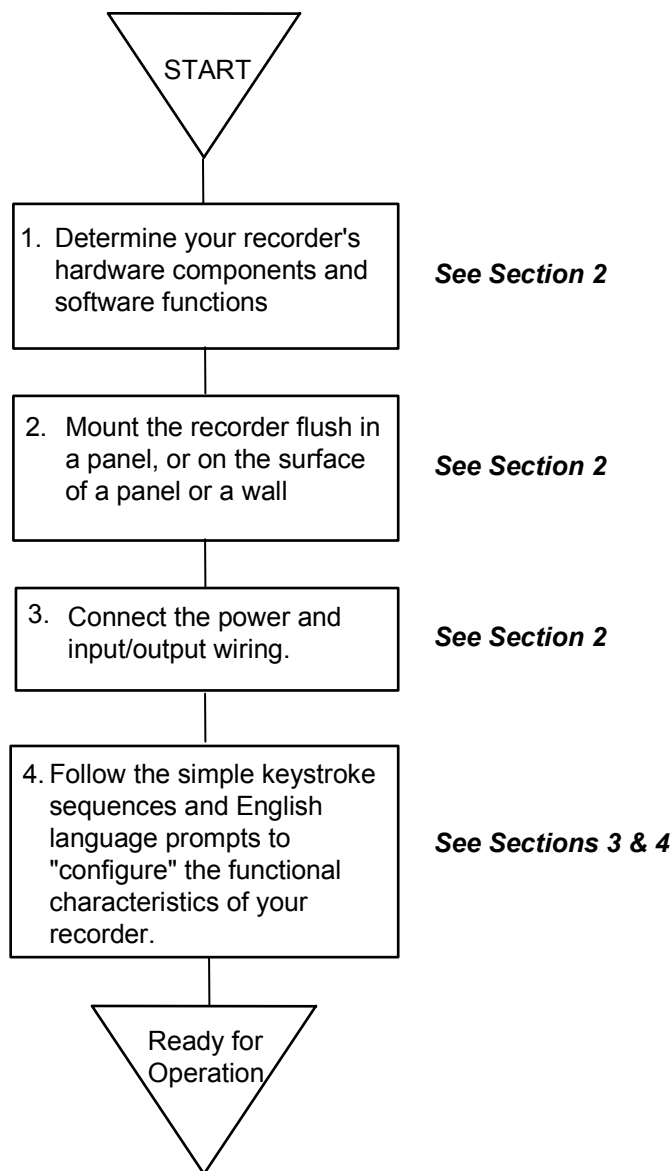

For Model DR45AR, also see Appendix A

21402

Figure 1-2 Set-up Tasks



## 2. Installation

### 2.1 Overview

#### Introduction

Installation of the DR4500A Recorder consists of mounting and wiring the recorder according to the instructions given in this section.

Read the preinstallation information, check the model number interpretation and become familiar with your model selections, then proceed with installation.

#### What's in this section?

This section contains the following information:

	Topic	See Page
2.1	Overview	7
2.2	Model Number Interpretation	13
2.3	Mounting Considerations and Overall Dimensions	16
2.4	Mounting Methods	17
2.5	Wiring Prerequisites	27
2.6	Input Wiring Procedures	29
2.7	Output Wiring Procedures	39
2.8	Option Wiring Procedures	45
2.9	Lockout Switch Configuration	54

#### Pre-installation information

If the recorder has not been removed from its shipping carton, inspect the carton for damage and remove the recorder. Inspect the unit for any obvious shipping damage and report any damage due to transit to the carrier.

Make sure a bag containing mounting hardware is included in the carton with the recorder.

Check that the model number shown on the chart plate agrees with what you have ordered.

#### CE Conformity special conditions (Europe)

Braid shielded twisted pair cables are required for all Analog I/O, Process Variable, RTD, Thermocouple, dc millivolt, low level signal, 4-20 mA, and relay output circuits. Supplementary bonding of the recorder enclosure to a local ground, using a 3/4" braided copper conductor, is required. Ferrite suppression filters and capacitor filters (see *Subsection 2.5* for Wiring Prerequisites) shall be installed on all cables connected to the recorder/controller.

Refer to document *51-52-05-01, How to Apply Digital Instrumentation in Severe Electrical Noise Environments*, for additional installation guidance.

## Operating limits and condensed specifications

We recommend that you review and adhere to the operating limits listed in Table 2-1 when you install your recorder.

**Table 2-1 Operating Limits and Condensed Specifications**

Condition	Specifications
<b>Ambient Temperature</b>	32 °F to 131 °F (0 °C to 55 °C)
<b>Relative Humidity</b>	5 % to 90 % RH at 40 °C (104 °F)
<b>Vibration</b> Frequency Acceleration	0 to 200 Hz 0.2 g
<b>Mechanical Shock</b> Acceleration Duration	5 g 30 ms
<b>Power</b>	102 Vac to 132 Vac      50/60 Hz 204 Vac to 264 Vac      50/60 Hz
<b>Power Consumption</b>	20 VA maximum
<b>Digital Indication Accuracy</b>	1 digit
<b>Minimum Input Span</b>	Range is fully configurable with span limitation of the operating range selected.
<b>Input Impedance</b>	4-20 mA dc: 250 ohms 0-10 Vdc: 200K ohms All others: 10 Megohms
<b>Source Impedance</b>	RTD: 100 ohms per lead maximum
<b>Sampling Rate</b>	Each input sampled 3 times a second (1 or 2 inputs); 3 times in 2 seconds (3 or 4 inputs).
<b>Input Filter</b>	Software: Single pole low pass section with selectable time constants (off to 120 seconds).
<b>Digital Displays</b>	Vacuum fluorescent, alphanumeric. A six-digit display dedicated to the process variable. Alternate information displayed during configuration mode. An eight-digit display shows key selected operating parameters. Also provides guidance during configuration.
<b>Indicators</b>	Channel PV display (CHN 1, 2, 3, or 4) Alarm status (ALM 1, 2) Controller Output (OUT 1, 2) Remote Setpoint (RSP) Temperature unit (F or C) or Engineering Units Controller's mode (A or MAN)
<b>Deviation Bargraph</b>	21 segment, color coded deviation bargraph: Green (large) = On Control Green (small) = Deviation to ± 10 % of PV
<b>Controller Modes of Operation</b>	Manual Operation Automatic with local setpoint Automatic with remote setpoint
<b>Transmitter Supply Voltage</b>	22 Vdc to 26 Vdc at input terminals (50 mA dc at 24 Vdc)

Condition	Specifications
<b>Controller Output<sup>1</sup> (Optional)</b>	<ul style="list-style-type: none"> <li>• <i>On-Off or Time Proportional</i> One SPST electromechanical relay. Control action can be set for direct or reverse; N.O. or N.C. contact selectable.</li> <li>• <i>On-Off Duplex or Time Proportional Duplex</i> Two SPST electromechanical relays. Control action can be set for direct or reverse; N.O. or N.C. contact selectable.</li> <li>• <i>Current Proportional</i> 21 mA dc maximum into a negative or positive grounded or non-grounded load of 0 to 1000 ohms. Output range can be set between 4 and 20 mA, and as direct or reverse action. <i>Resolution: 10 bits</i> <i>Accuracy: 0.5 % full scale</i> FM Approved Output (optional)</li> <li>• <i>Position Proportional and Three Position Step</i> Two SPST electromechanical relays operate motor having a 100 ohm to 1000 ohm slidewire.</li> <li>• <i>Current/Time Duplex and Time/Current Duplex</i> Variation of time proportional duplex for Heat/Cool applications. Time proportional output (heat or cool) is a SPST electromechanical relay. Current proportional output (heat or cool) is a 4-20 mA signal that can be fed into a negative or positive grounded load of 0 to 1000 ohms and is operational over 50 % of range or the entire range. <i>Time Proportional Relay Resolution: 4.4 mSec</i> Relay Contact Ratings:     Resistive Load: 5 A @ 120 Vac, 2.5 A @ 240 Vac     Inductive Load: 50 VA @ 120 Vac or 240 Vac Cycle Time: 1 second to 120 seconds <i>Current Proportional:</i>     Resolution: 10 bits     Accuracy: 0.5 % full scale</li> </ul>
<b>Auxiliary Output (Optional)</b>	<p>21 mA dc maximum into a negative or positive grounded load of 0 to 1000 ohms. The range can be set between 0 to 21 mA. It can be configured to represent any one of 12 control parameters.</p> <p><i>Resolution: 12 bits over 0 to 21 mA</i> <i>Accuracy: 0.2 % of full scale</i> <i>Temperature Stability: 0.03 % F.S./°C</i></p>

Types of Input Actuations <sup>2</sup>	Range		Reference Accuracy		Temp Stability ± Degrees Error Per 1 Degree ΔT
	°F	°C	± °F	± °C	
<b>Thermocouples<sup>3</sup></b>					
B	<b>105 to 3300</b> 105 to 150 150 to 500 500 to 1000 1000 to 3300	<b>41 to 1816</b> 41 to 66 66 to 260 260 to 538 538 to 1815	42.00 14.00 3.00 1.50	23.00 7.70 1.70 0.80	2.00 2.00 0.50 0.20
E	<b>-454 to 1832</b> -454 to -202 -202 to 1832	<b>-270 to 1000</b> -270 to -130 -130 to 1000	18.00 1.00	10.00 0.55	0.70 0.35
E (low)	<b>-200 to 1100</b>	<b>-129 to 593</b>	0.50	0.30	0.20
J	<b>0 to 1600</b>	<b>-18 to 871</b>	0.40	0.22	0.06
J (low)	<b>20 to 770</b>	<b>-7 to 410</b>	0.20	0.11	0.04
K	<b>-320 to 2500</b> -320 to 0 0 to 2500	<b>-196 to 1371</b> -196 to -18 -18 to 1371	1.25 0.60	0.70 0.35	0.18 0.09
K (low)	<b>-20 to 1000</b>	<b>-29 to 538</b>	0.30	0.16	0.05
NNM (Ni Ni Moly)	<b>32 to 2500</b> 32 to 500 500 to 2500	<b>0 to 1371</b> 0 to 260 260 to 1371	0.75 0.50	0.40 0.30	0.09 0.07
NIC (Nicrosil-Nisil)	<b>0 to 2372</b>	<b>-18 to 1300</b>	1.0	0.55	0.01
R	<b>0 to 3100</b> 0 to 500 500 to 3100	<b>-18 to 1704</b> -18 to 260 260 to 1704	2.00 1.00	1.10 0.55	0.25 0.13
S	<b>0 to 3100</b> 0 to 500 500 to 3100	<b>-18 to 1704</b> -18 to 260 260 to 1704	2.00 1.00	1.10 0.55	0.23 0.13
T	<b>-300 to 700</b>	<b>-184 to 371</b>	0.60	0.35	0.07
T (low)	<b>-200 to 600</b>	<b>-129 to 316</b>	0.40	0.22	0.07
W5W26	<b>0 to 4200</b> 0 to 600 600 to 3600 3600 to 4200	<b>-18 to 2315</b> -18 to 316 316 to 1982 1982 to 2315	1.40 1.30 1.60	0.77 0.70 0.90	0.17 0.17 0.29
W5W26 (low)	<b>0 to 2240</b> 0 to 600 600 to 2240	<b>-18 to 1227</b> -18 to 316 316 to 1227	1.10 1.00	0.60 0.55	0.14 0.10
<b>Radiamatic</b>	<b>1400 to 3400</b>	<b>760 to 1871</b>	1.00	0.55	0.10
<b>RTD</b>					
Platinum					
100 ohms	<b>-300 to 900</b>	<b>-184 to 482</b>	0.40	0.22	0.05
200 ohms (high) <sup>5</sup>	<b>32 to 752</b>	<b>0 to 400</b>	0.30	0.16	0.05
200 ohms (low) <sup>5</sup>	<b>32 to 392</b>	<b>0 to 200</b>	0.20	0.12	0.05
500 ohms	<b>-300 to 900</b>	<b>-184 to 482</b>	0.20	0.11	0.05



Types of Input Actuations <sup>2</sup>	Range		Reference Accuracy		Temp Stability ± Degrees Error Per 1 Degree ΔT
	°F	°C	± °F	± °C	
<b>Linear</b>					
Milliamperes dc	4 to 20	—	0.10 %	—	0.004 %/°F
Millivolts dc	0 to 10 10 to 50	—	0.05 % 0.05 %	—	0.004 %/°F 0.004 %/°F
Volts dc	1 to 5 (can be calibrated 0 to 5) 0 to 10	—	0.05 % 0.10 %	—	0.004 %/°F 0.004 %/°F
<b>Relative Humidity</b> Platinum 100 ohm Wet/Dry Bulb*					
<b>Wet/Dry Input</b>	<b>-130 to 392</b>	<b>-90 to 200</b>	0.30	0.03	0.03
	<b>Measured % RH</b>	<b>Dry Bulb Range</b>		<b>Reference Accuracy</b>	<b>Temp. Stability 53 °F to 104 °F/ 12 °C to 40 °C</b>
<b>% RH<sup>4</sup></b>	0 to <20 20 to 100	-103 to 212 35 to 40 >40 to 100 100 to 212	-75 to 100 2 to 4 >4 to 38 38 to 100	2 % RH 2 % RH 1 % RH 1 % RH	0.11 % RH/°F 0.11 %RH/°F 0.06 % RH/°F 0.03 % RH/°F

Condition	Specifications
<b>Case</b>	Molded, foamed-Noryl** with gasketed door. A UL and FM approved NEMA4X door is also available.
<b>Chart</b>	12-inch (304.8 mm) diameter chart. Plain thermal-sensitive paper.
<b>Wiring Connections</b>	Terminals inside the case.
<b>Color</b>	Case: Black Door (standard): Caribbean Blue, Black, or Gray
<b>Approval Bodies</b>	U.L. Approval depending on model. CSA Approval. Consult Model Selection Guide for information. FM approved for Class I, Div. 2, Groups A, B, C, D areas depending on model.
<b>Weight</b>	13.2 lbs (6 kg)
<b>Mounting</b>	Panel, 2-inch pipe, or surface mounted. Some adapter kits available for existing panel cutouts.
<b>OPTIONS</b>	
<b>Alarm Output</b>	Two, four, or six relays available. <i>Relay Contact Ratings:</i> <i>First Relays, Resistive Load: 1 A @ 120 Vac, 1/2 A @ 240 Vac</i> <i>Relays 3 through 6, Resistive Load: 5 A @ 120 Vac, 2.5 A @ 240 Vac</i>
<b>Digital Input</b>	+20 Vdc source for external dry contact or isolated solid state contacts. Selects one configured input.
<b>Totalizers</b>	One to four totalizers depending on model. Eight digit "totals" with multiplier on digital display; 14 digit totalization printout on chart.
<b>RS485 Modbus RTU Communications</b>	<i>Baud rate:</i> 300, 600, 1200, 2400, 4800, 9600, 19,200, 38,400 <i>Protocol:</i> RS485 Modbus RTU Communications <i>Length of Link:</i> 4000 ft (1,219 m) maximum <i>Link Characteristics:</i> Two-wire, multidrop

Condition	Specifications
<b>Calculations</b>	F <sub>o</sub> calculation available on DR45AR, Math function.
<b>Miscellaneous</b>	<ul style="list-style-type: none"> <li>• FM Approved 4-20 mA Control Output</li> <li>• A UL and FM approved NEMA4X door</li> <li>• Door Lock</li> <li>• External Keypad</li> <li>• Chart Illumination</li> <li>• U.L. Listing, CSA Approval, FM Class I Div. 2</li> <li>• Control with Accutune II Tuning capability</li> <li>• Math</li> <li>• Glass or Acrylic Window</li> <li>• Configuration Lockout Switch</li> <li>• Customer ID Tag (30 characters maximum)</li> <li>• Pulse output counter alarm function on DR45AW model</li> </ul>
<b>CE Conformity (Europe)</b>	This product is in conformity with the protection requirements of the following European Council Directives: <b>73/23/EEC</b> , the Low Voltage Directive, and <b>89/336/EEC</b> , the EMC Directive. Conformity of this product with any other “CE Mark” Directive(s) shall not be assumed.
<b>Product Classification</b>	Class 1: Permanently connected, Panel/Surface Mounted Industrial Control Equipment with protective earthing (grounding). (EN 61010-1)
<b>Enclosure Rating</b>	Panel/Surface Mounted Equipment, IP 54. (ref. IEC 529)
<b>Installation Category (Overvoltage Category)</b>	Category II: Energy-consuming equipment supplied from the fixed installation. Local level appliances, and Industrial Control Equipment. (EN 61010-1)
<b>Pollution Degree</b>	Pollution Degree 2: Normally non-conductive pollution with occasional conductivity caused by condensation. (ref. IEC 664-10)
<b>EMC Classification</b>	Group 1, Class A, ESM Equipment (EN 55011, emissions), Industrial Equipment (EN 50082-2, immunity)
<b>Method of EMC Assessment</b>	Technical File (TF)
<b>Declaration of Conformity</b>	Document #51197639-000

\*IEC Alpha ( $\alpha$ ) = 0.00385  $\Omega/\Omega/^\circ\text{C}$

\*\*Registered Trademark—General Electric Co.

<sup>1</sup> Not all controller outputs are available on all models of the Truline Recorder. Consult Model Selection Guide for information.

<sup>2</sup> Not all Input Actuations are available on all models of the Truline Recorder. Consult Model Selection Guide for information.

<sup>3</sup> Includes reference junction calibration of  $\pm 0.01$  degrees using standard “ice bath” method of calibration. Factory calibration at reference  $\pm 1.2$  °F. Note that factory calibration may vary by as much as  $\pm 10$  microvolts or  $\pm 0.3$  ohms for RTDs, which means recalibration may be required to achieve stated accuracy.

<sup>4</sup> The RH calculation is inoperative when temperature goes below 32 °F (0 °C) or above 212 °F (100 °C). However, the dry bulb temperature will be monitored to -103 °F (-75 °C). Accuracy stated is for Classic Series Recorder only, and does not include remaining system accuracies.

<sup>5</sup> Only available with Model DR45AR.

## 2.2 Model Number Interpretation

### Model number

The model number interpretation is shown in Figure 2-1. Write the model number into the spaces provided and compare it to the model number interpretation. This information will also be useful when you wire your recorder. The example on the next page will help you to decode the model.

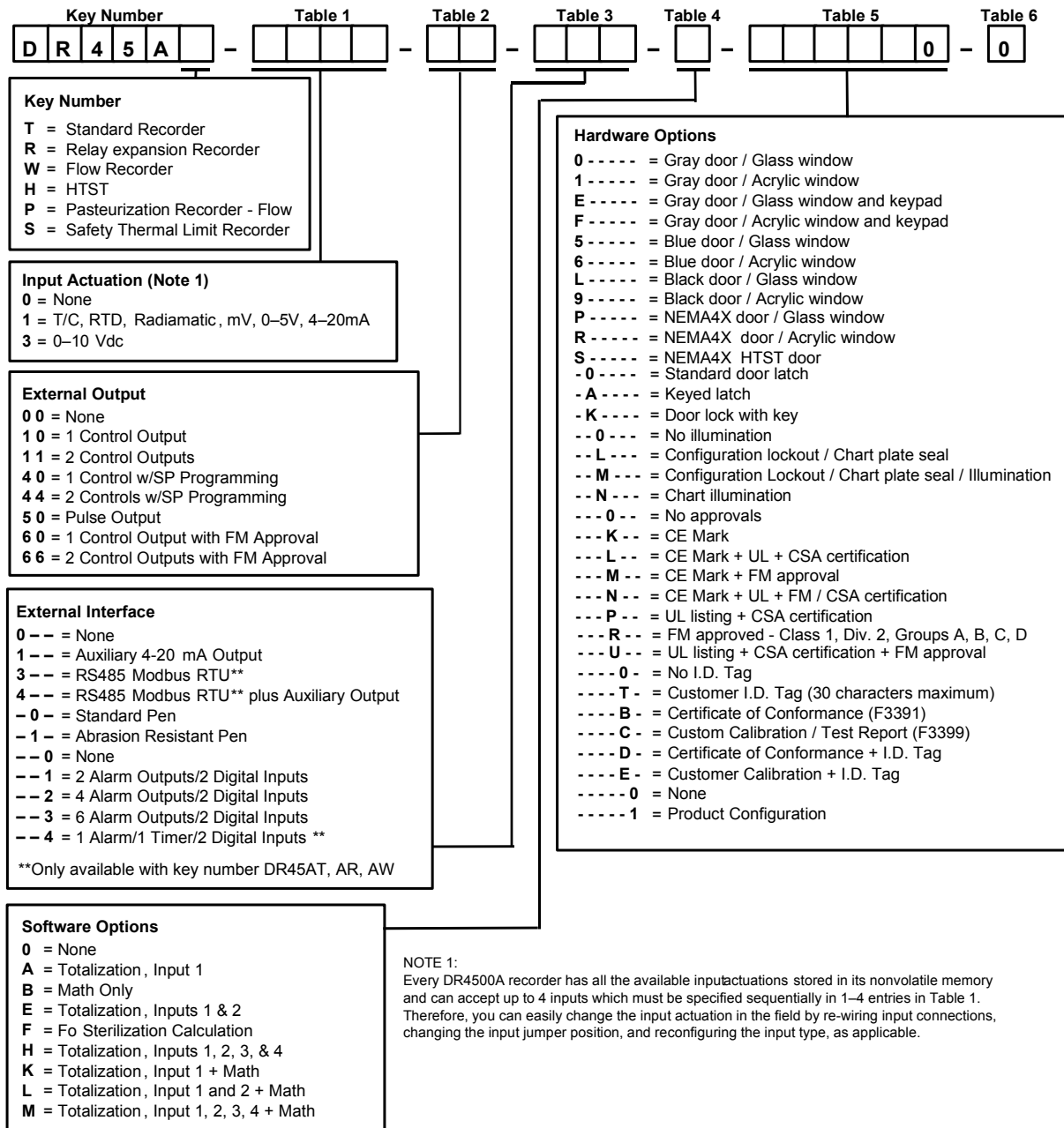

**Figure 2-1 Model Number Interpretation**

### Example of model number decoding

Assume that the model number on the label is

DR45AT - 1300 - 44 - 001 - A - 1KN0T0 - 0

Using the table code definitions from Figure 2-1, this recorder has the following features and options:

- 2-input type with thermocouple, RTD, Radiamatic, mV, 0-5 Vdc or 4-20 mA input for channel 1
- 0-10 Vdc input for channel 2
- Two controllers with setpoint programming capability
- Alarm output / digital input capability
- High speed pen
- Totalization for input 1
- Gray door with acrylic window
- Door lock
- Chart illumination
- Customer I.D. tag
- No approvals

### Location of hardware components

After you decode your recorder's model number, refer to Figure 2-2 to match "table" selections with the location of actual recorder hardware components. This will help you to determine applicable input / output wiring requirements, as well as identify appropriate software functions to be configured later.

To access and view the actual components inside your recorder, follow the procedure in Table 2-2.

**Table 2-2 Procedure to Access Components**

<b>Step</b>	<b>Action</b>
<b>1</b>	Turn the latch on the recorder door and swing the door open.
<b>2</b>	Loosen the captive screw on the right hand side of the chart plate and swing the chart plate out.
<b>3</b>	Reverse the steps to close the chart plate and door.

**View of hardware components**

Figure 2-2 shows the location of the actual hardware components for key number DR45AT. If key number is DR45AR, see Appendix A for internal views.

**Key Number: DR 45AT\***

\* If Key number is DR45AR, see Appendix A for internal views.

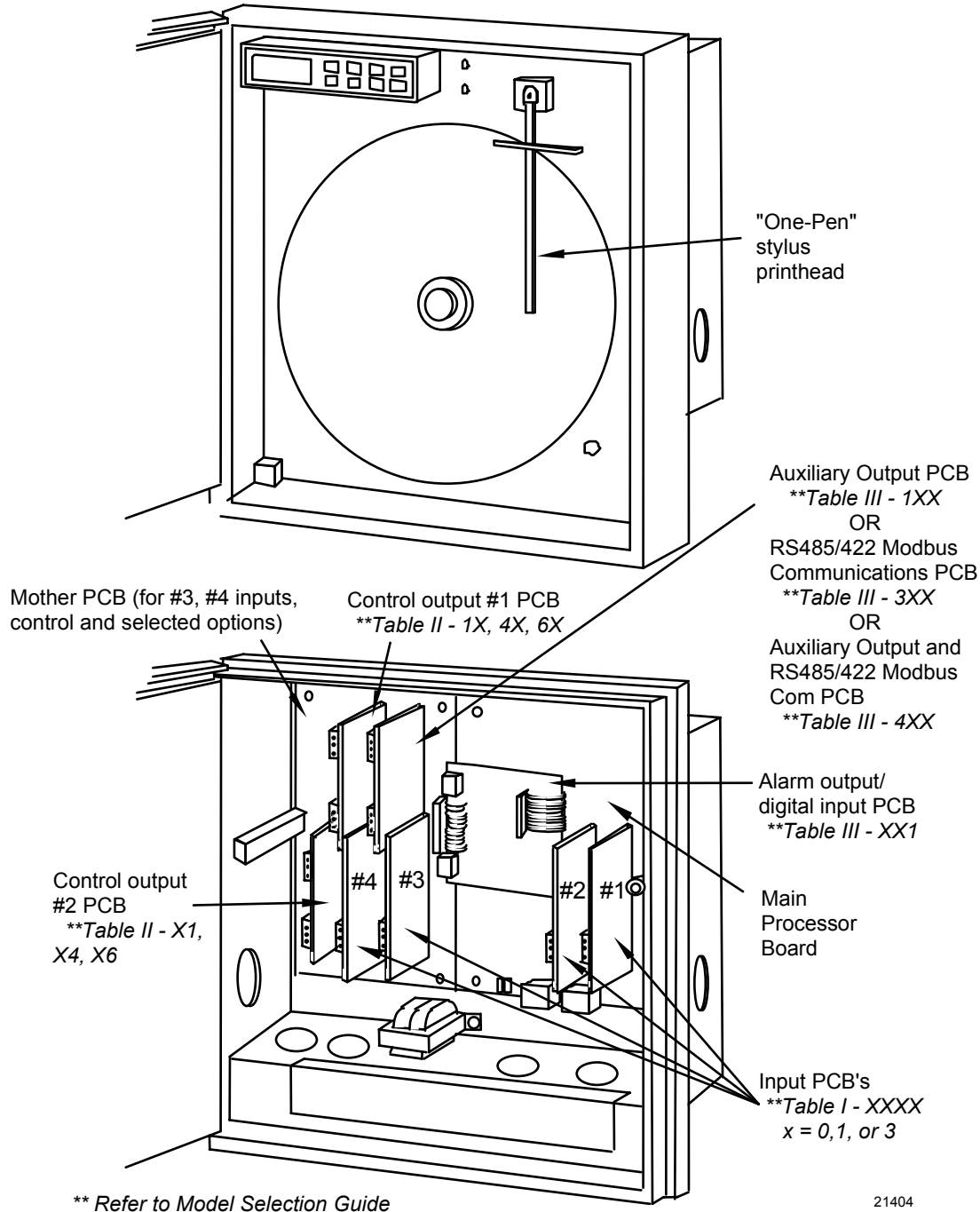

**Figure 2-2 DR4500A Recorder Hardware Components Versus "Table" Selections**

## 2.3 Mounting Considerations and Overall Dimensions

### Physical considerations

The recorder can be mounted in a panel by making a new cutout or using an existing cutout with a filler plate (see Table 2-4). Use the mounting kit supplied. Adequate access space must be available at the back of the panel for installation and servicing activities.

The overall dimensions and panel cutout requirements for mounting the recorder are shown in Figure 2-3.

### Overall dimensions

Figure 2-3 shows the overall dimensions for mounting the recorder.

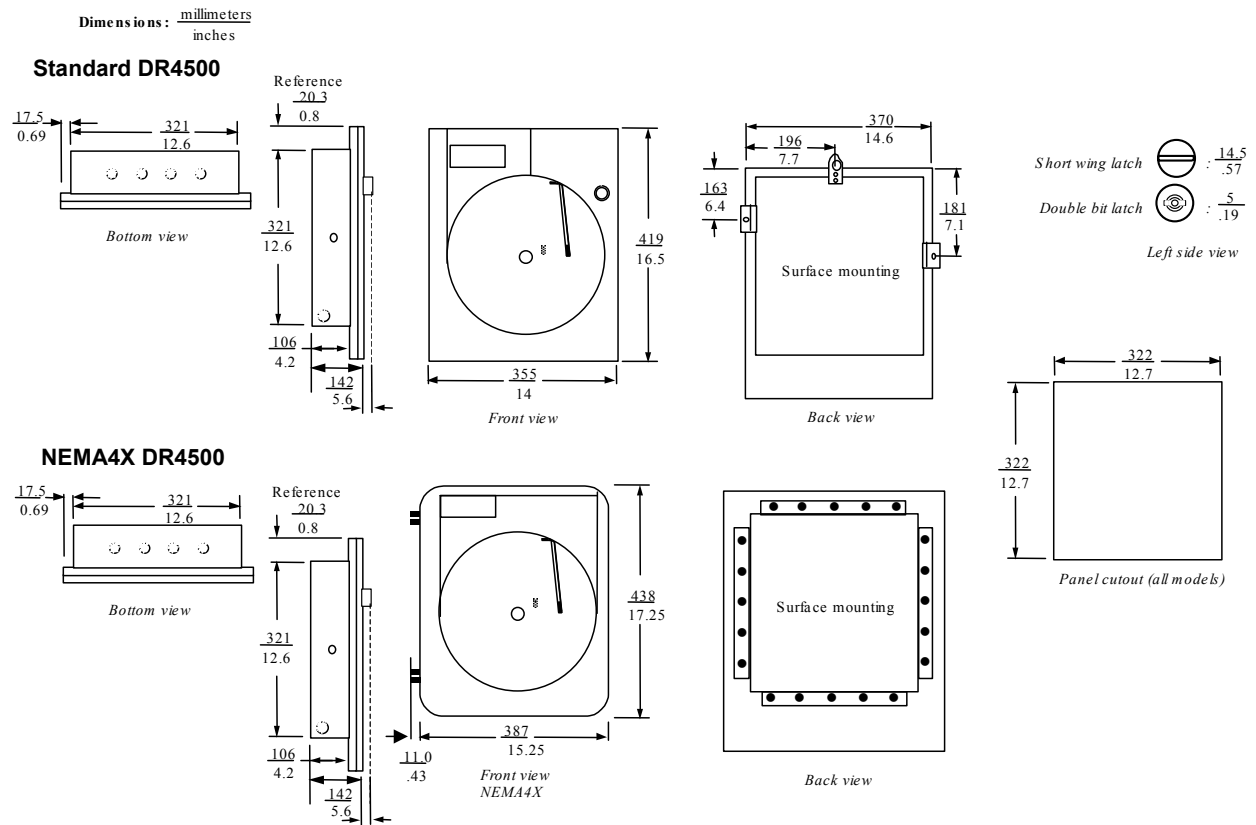

Figure 2-3 Overall Dimensions

## 2.4 Mounting Methods

### Introduction

There are several methods available for mounting your recorder.

- Flush in Panel (new panel cutout)
- Flush in Panel (using an existing panel cutout)
  - using universal filler plate kit
  - using cutout made for Kent Model 105M
- Flush in Panel for recorders with NEMA4 Door
- On a 2-inch Pipe
- On Surface (of panel or wall)

Procedures for each method follow. Choose the one that meets your mounting requirements. Use the associated dimension drawings for reference.

### How to remove knockouts for conduits

Before you mount the recorder, remove the appropriate “knockouts” in the bottom and/or sides of the recorder case for wire entry via 1/2" (12.7 mm) conduits. Refer to Figure 2-4 for knockout locations.



#### ATTENTION

The knockouts are really plugs that you just have to push out to remove.

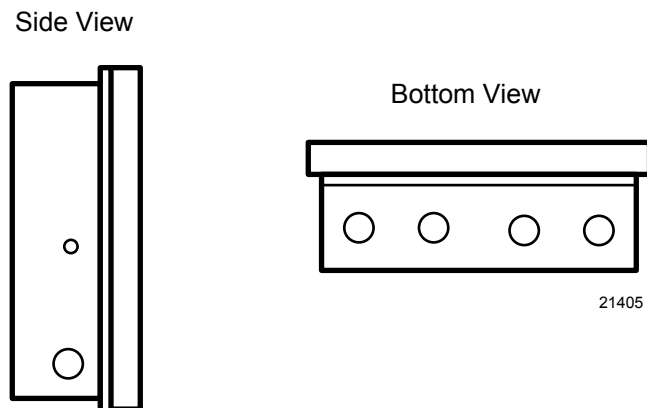

**Figure 2-4 How to Remove Knockouts**

### Mounting flush in panel (New panel cutout)

Refer to Figure 2-5 and follow the procedure in Table 2-3 to make a new cutout in a panel and mount your recorder in the cutout.

**Table 2-3 Mounting Flush in a New Panel Cutout**

Step	Action
1	At the appropriate location, make a square cutout in the panel measuring $12.7 \pm 0.060$ inches by $12.7 \pm 0.060$ inches ( $322.58 \pm 1.52$ by $322.58 \pm 1.52$ millimeters). See Figure 2-3.
2	Orient the recorder case properly and slide it into the cutout from the front of the panel. Support the recorder as shown in steps 3 and 4.
3	Refer to Figure 2-5. From the back of the panel, attach a mounting bracket to each side of the recorder case using a $1/4$ -20 x $1/2$ inch hex screw and a lockwasher for each bracket (mounting hardware supplied with recorder). Leave the screws slightly loose so you can adjust the brackets.
4	While holding the recorder firmly against the panel, slide each bracket against the back of the panel and tighten the screws.

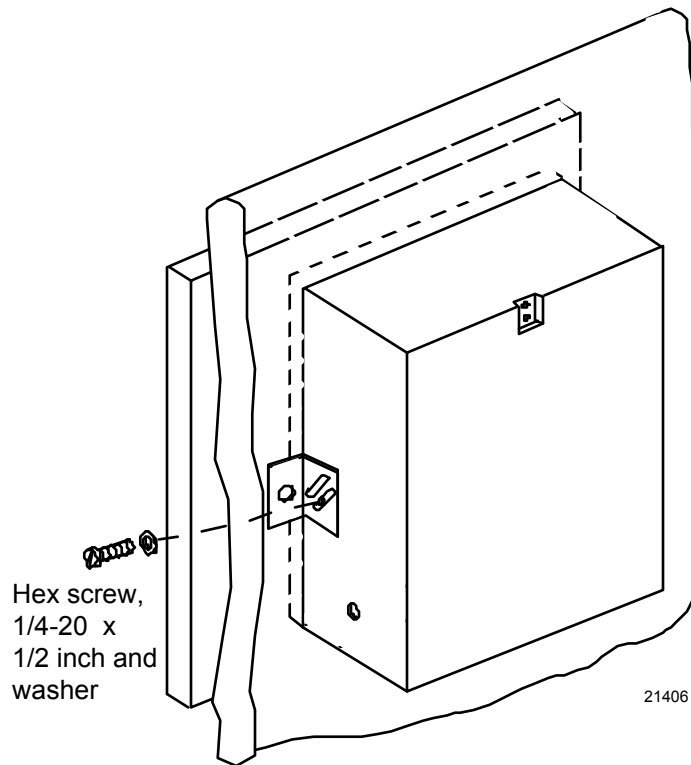

**Figure 2-5 Mounting Flush in a New Panel Cutout**



**Reference data for existing panel cutouts**

Refer to Table 2-4 to determine whether the existing panel cutout can be used. Use the procedure for mounting with the universal filler kit unless otherwise noted.

**Table 2-4 Reference Data for Mounting DR4500A in Existing Panel Cutouts**

Manufacturer / Instrument	Dimensions of Existing Panel Cutout (inches)	Need Universal Filler Plate Kit 30755134-001 Blue Color 30755134-002 Gray Color
Honeywell/Model AR100*, DR4200	12.7 x 12.7	No*
Honeywell/Class 15	15.8 x 17.2	Yes
Honeywell/Class 45	13.12 x 17.12	Yes
Badger Meter/Model Micro Chart	14.25 x 17.88	Yes
Bristol/Models 4330, 500 Classes 1, 2A, 3B, and 5	3.56 x 18.56	Yes
Fisher and Porter/Model 51-1100	13.75 x 17.31	Yes
Foxboro/Model 40	14.38 x 17.06	Yes
Kent/Model 105M**	13.6 x 13.46	No**
Partlow/Model ER*	13.5 x 12.69	No*
Taylor/Model 76J	13.78 x 16.5	Yes

\*No adaptation is required, use procedure for “Flush in Panel - New Panel Cutout”

\*\*Use procedure for “Cutout made for Kent Model 105M”

**Adapter plate dimensions**

The dimensions of the adapter plate (part number 30755134) are 16.5” x 19”.

### Mounting flush in panel (using universal filler plate kit)

Refer to Figure 2-6 and follow the procedure in Table 2-5 to mount your recorder in an existing cutout using the Universal Filler Kit.

**Table 2-5 Mounting Flush in a Panel Using Universal Filler Kit**

Step	Action
1	Lay the recorder face down on a clean work surface and position the universal filler plate as shown in Figure 2-6.
2	Measure the height of the existing panel cutout.
3	Refer to Figure 2-6. Position the support brackets, supplied with the kit, so that the distance from the top of the "window" in the filler plate to the right angle of the support brackets is just less than the height of the existing panel cutout.
4	Secure brackets with two 10-32 x 1/4 inch screws, provided in the kit, by inserting them through the holes in the filler plate into the tapped screw holes in the recorder case.
5	Insert the recorder into the cutout from the front of the panel as shown in Figure 2-6.
6	Refer to Figure 2-6. From the back of the panel attach a mounting bracket to each side of the recorder case using a 1/4-20 x 1/2-inch hex screw and a lockwasher for each bracket (mounting hardware supplied with recorder). Leave the screws slightly loose so you can adjust the brackets.
7	While holding the recorder firmly against the panel, slide each bracket against the back of the panel and tighten the screws.

NOTE: Universal filler plate and attaching hardware are included in kit 30755134-xxx

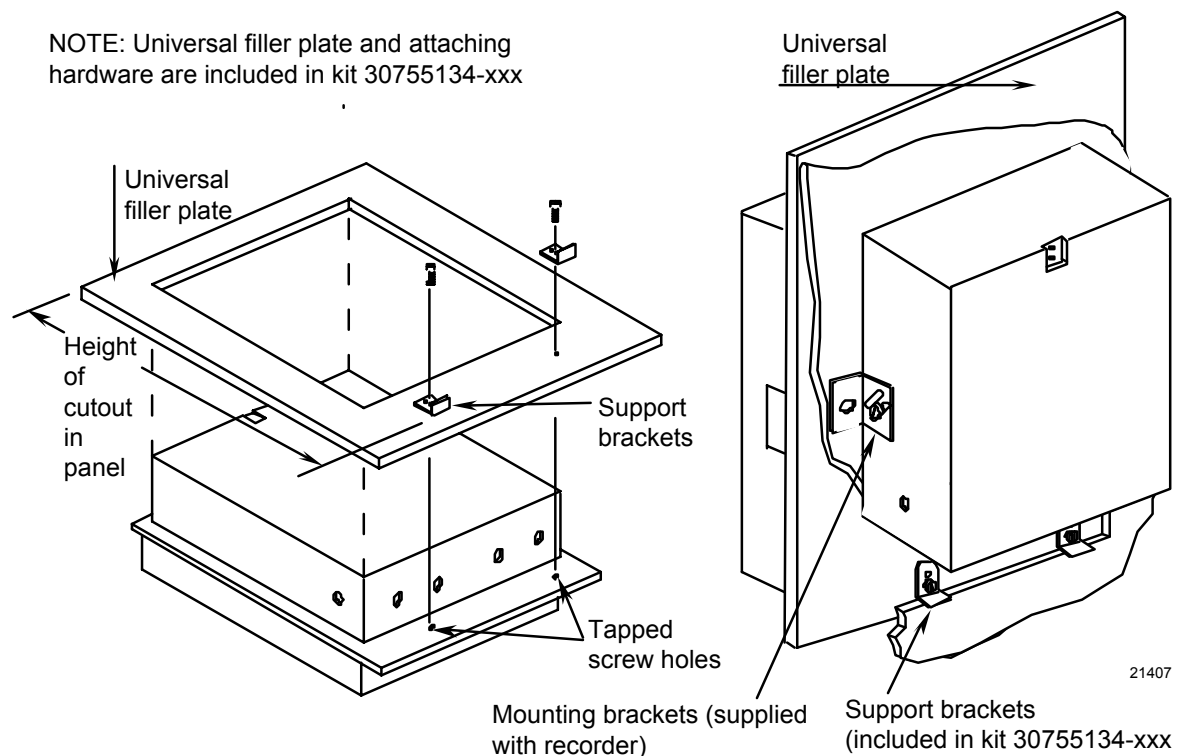

**Figure 2-6 Mounting in a Panel Using Universal Filler Kit**

### Mounting flush in panel (using cutout made for Kent Model 105M)

Refer to Figure 2-7 and follow the procedure in Table 2-6 to mount your recorder in an existing cutout using the cutout made for Kent Model 105M.

**Table 2-6 Mounting Flush in a Panel Using Kent Model 105M Cutout**

Step	Action
1	Drill two 1/4-inch holes in the back of the panel as shown in Figure 2-7. These holes are for 10-32 screws to be inserted from back of panel into threaded inserts in the back of the recorder case.  <b>ATTENTION</b> If the panel is more than 1/4-inch thick, substitute 10-32 x 1/2-inch long screws for the 3/8-inch long screws supplied with the recorder.
2	While supporting the recorder, insert it through the panel cutout and orient the case so that the threaded inserts at the bottom of the case align with the holes drilled in the panel.
3	From the rear of the panel, insert two 10-32 pan head screws of appropriate length into threaded inserts in the recorder case.
4	From the back of the panel, attach a mounting bracket to each side of the recorder case using a 1/4-20 x 1/2-inch hex screw and a lockwasher for each bracket (mounting hardware supplied with recorder). Leave the screws slightly loose so you can adjust the brackets.
5	While holding the recorder firmly against the panel, slide each bracket against the back of the panel and tighten the screws.

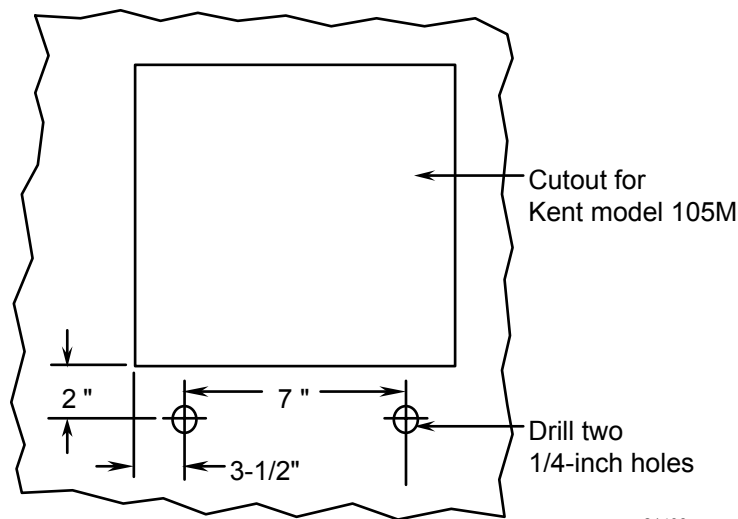

21408

**Figure 2-7 Mounting in a Panel using Kent Model 105M Cutout**

### Panel mounting recorder with NEMA4X door

Refer to Figure 2-8 and follow the procedure in Table 2-7 to panel-mount your recorder if it has a NEMA4X door.

**Table 2-7 Procedure for Mounting Recorder with NEMA4X Door**

Step	Action
1	Place the panel gasket onto the rear flange of the recorder case.
2	Install five #8-32 x 3/4 screws on each of the four mounting brackets so the ends of the screw threads are flush with the face of the bracket.  NOTE: Screw heads to be flange side of brackets.
3	Insert the case with gasket into the panel opening.
4	Position the bracket so that the tabs on the end of the bracket slide into the holes in the case, Secure the four brackets with 1/4-20 x 5/8 long bolts and lockwashers; one to the top, bottom and each side of the case. Tighten the bolts.
5	Start to tighten the #8-32 x 3/4 screws on a bracket. Tighten the end screws first then those toward the middle until all five screws have a 5 to 8 lb-in of torque applied. Do the same to both the other three brackets.  When completed all twenty screws should have a 5 to 8 lb-in of torque applied. This assures that the case and panel gaskets are adequately sealed against the panel.

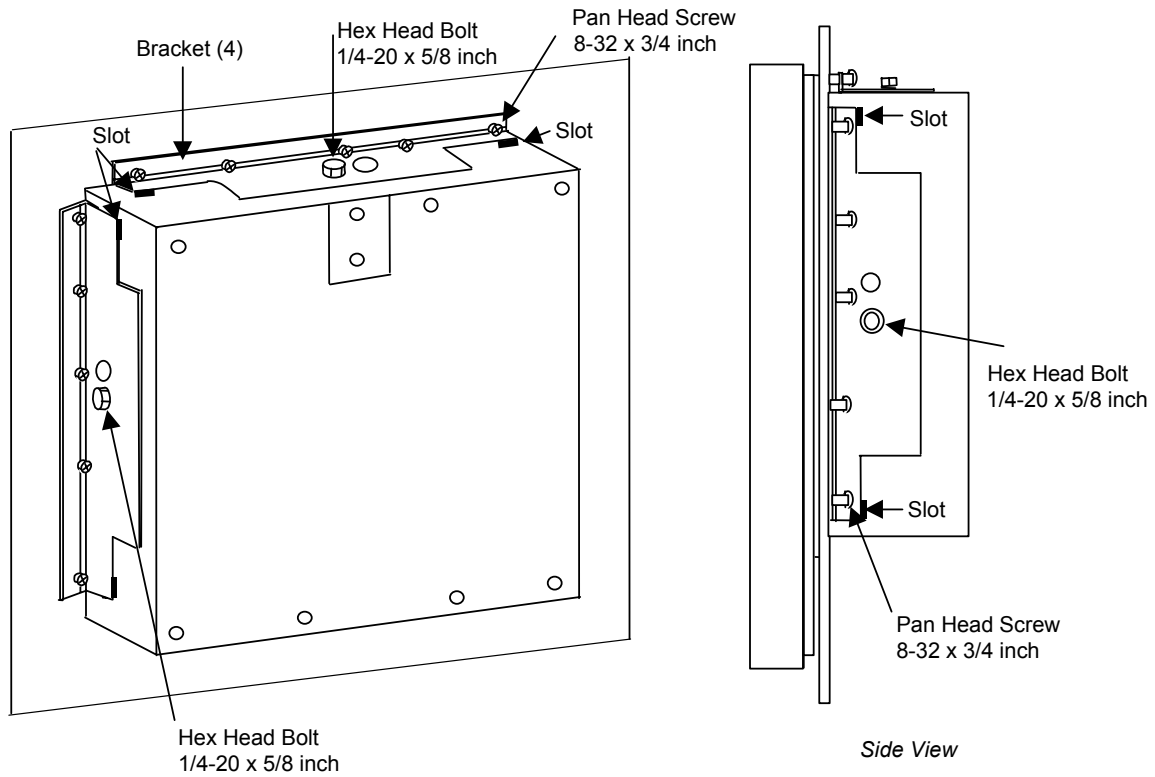

NOTE: Mounting brackets, attaching hardware, and panel gasket are included in kit 30755065-503

**Figure 2-8 Panel Mounting Recorder with NEMA4X Door**

### Mounting on a 2-inch pipe

Refer to Figure 2-9 and follow the procedure in Table 2-8 to mount your recorder on a 2-inch pipe.

**Table 2-8 Pipe Mounting Procedure**

Step	Action
1	Using the eight plastite screws supplied with the pipe mounting bracket kit, attach the two mounting brackets (flat side against the case) to the back of the recorder. Refer to Figure 2-9 for location.
2	Position the recorder with brackets on the 2-inch pipe.
3	Install the U-bolts around the pipe and through the bracket holes. Secure with lockwashers and hex nuts provided.

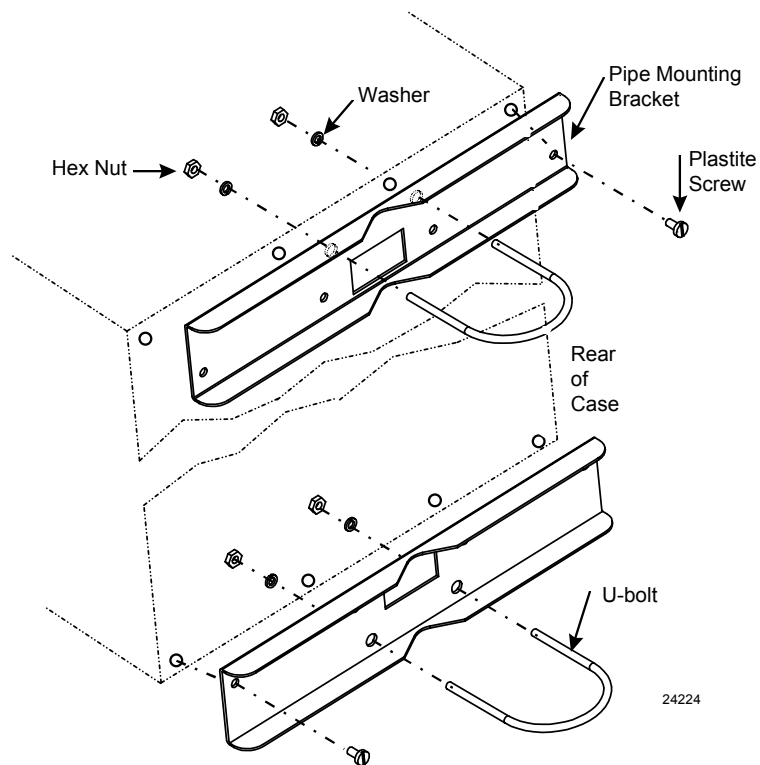

**Figure 2-9 Pipe Mounting Brackets**

### Mounting on surface (of panel or wall)

Refer to Figure 2-10 and follow the procedure in Table 2-9 to mount your recorder on a surface (panel or wall).



#### ATTENTION

You must supply three (3) screws for attaching the mounting hardware (brackets and support hook) to panel or wall.

**Table 2-9 Mounting Flush on a Surface (of Panel or Wall)**

Step	Action
1	Using two flat-head 10-32 x 1/4-inch screws supplied with the recorder, fasten the support hook into the recess at the back of the recorder case as shown in Figure 2-10.
2	Using 1/4-20 x 1/2-inch hex screws and lockwashers, attach a mounting bracket to each side of the case. Leave the screws slightly loose so as to permit some adjustments of the brackets.
3	On the panel mark the locations for the three holes as shown by the hole pattern in Figure 2-10.
4	Using a drill of appropriate size for user-supplied screws, drill a hole in the front of the panel for the eye of the support hook.
5	Insert the screws for the support hook into the panel, allowing the screw head to protrude approximately 5/16-inch.
6	Hang the recorder support hook on the screw. Make sure that the locations for the other two holes (marked in step three) are correct. If not, make sure that the recorder is aligned vertically and use the brackets as templates to mark the proper locations.
7	Remove the recorder from the panel and drill the other two holes.
8	Hang the recorder on the screw by the support hook and insert the other two user-supplied screws through the brackets into the panel. Tighten the two hex screws that attach the brackets to the case.

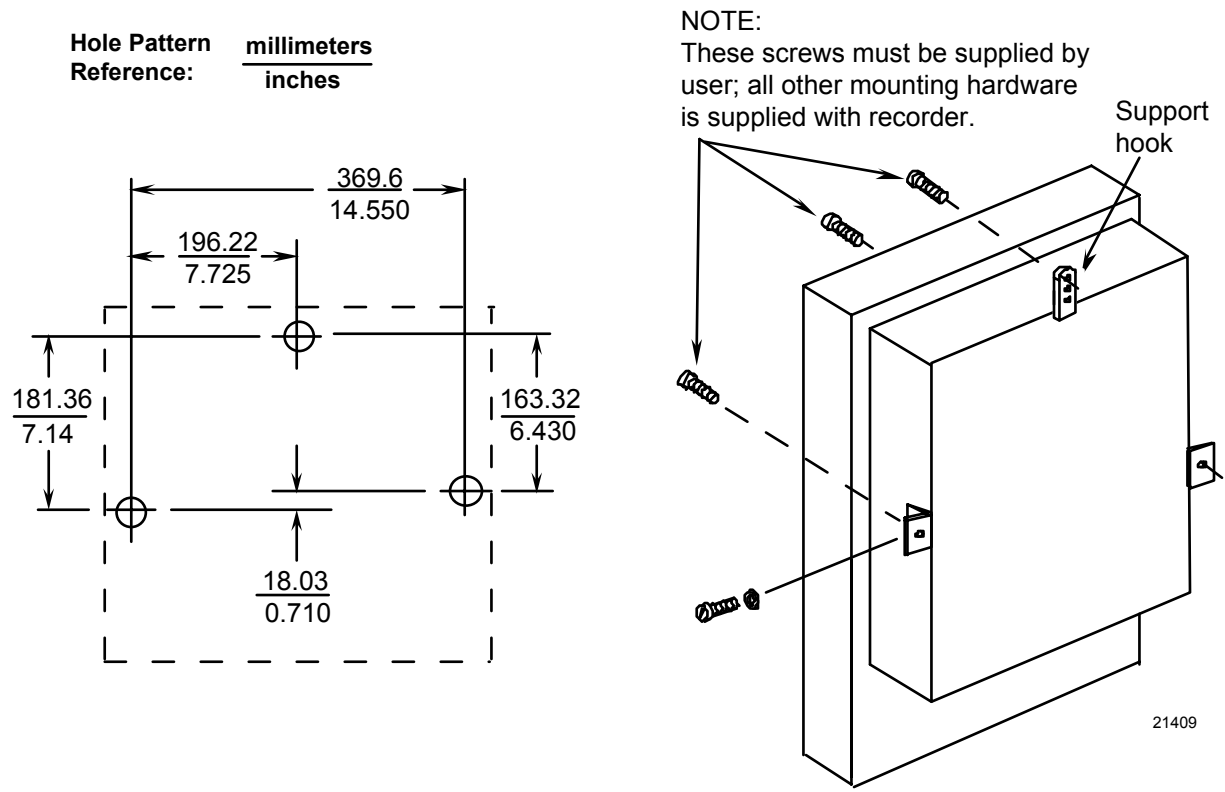

**Figure 2-10 Mounting Flush on a Surface (of Panel or Wall)**



## 2.5 Wiring Prerequisites

### Taking electrical noise precautions

Electrical noise is composed of unabated electrical signals which produce undesirable effects in measurements and control circuits.

Digital equipment is especially sensitive to the effects of electrical noise. Your recorder has built-in circuits to reduce the effect of electrical noise from various sources. If there is a need to further reduce these effects:

- Separate External Wiring - separate connecting wires into bundles (see Table 2-10) and route the individual bundles through separate conduits or metal trays.
- Use Suppression Devices - for additional noise protection, you may want to add suppression devices at the external source; appropriate suppression devices are commercially available.



#### REFERENCE

For additional noise information, refer to *document number 51-52-05-01*.

---

### Electrical considerations



The recorder is considered “rack and panel mounted equipment” per EN 61010-1, Safety Requirements for Electrical Equipment for Measurement, Control, and Laboratory Use, Part 1: General Requirements.

### Recorder grounding



PROTECTIVE BONDING (grounding) of this recorder shall be in accordance with National and local electrical codes.

### Functional earth



To minimize electrical noise and transients that may adversely affect the system, supplementary bonding of the recorder enclosure to a functional earth ground, using a 3/4” braided copper conductor, is required.

A terminal on the rear of the recorder is provided for this connection.

### CE conformity special conditions (Europe)

Braid shielded cable is required for all Input I/O and Output Relay cables. All recorder cable shield wires, except the RS485 Modbus communications cable shield, must be connected to a low impedance earth ground at the recorder. This can be done by bussing the shields to an earth ground point, or by connecting the shields to the conduit entry fittings if they are in electrical contact with the enclosure conductive coating. In either case, the shields shall not extend into the recorder enclosure. The cable shields shall also be connected to a low impedance earth ground at the farthest end of the cable, through a 0.0047 uF capacitor. See each of the individual wiring diagrams.

For the RS485 Modbus communications cable, Alpha XTRA Guard I cable (Alpha P/N 5121C) is required. At the recorder end, the communications cable shield must be unconnected and must not extend into the recorder enclosure. The shield of the communications cable must be connected to earth ground at the farthest end of the cable. See the option wiring procedure for the RS485 Communications Card.

Inside of the enclosure, the user must install ferrite suppression filters and capacitors on all wires connected to the recorder. ©Fair-Rite Products Corp. part number 0443164151, or equivalent, shall be installed as shown in Figure 2-11 to Figure 2-22, one filter for each circuit group.

Cable with an outer jacket diameter larger than 6.7 mm (0.264 in.) may require the outer jacket to be removed to fit the required one turn in the filter, or the selection of a different cable.

### Permissible wire bundling

Table 2-10 shows which wire functions should be bundled together.

**Table 2-10 Permissible Wiring Bundling**

<b>Bundle No.</b>	<b>Wire Functions</b>
1	<ul style="list-style-type: none"><li>• Line power wiring</li><li>• Earth ground wiring</li><li>• Control relay output wiring</li><li>• Line voltage alarm wiring</li></ul>
2	Analog signal wire, such as: <ul style="list-style-type: none"><li>• Input signal wire (thermocouple, 4 to 20 mA, etc.)</li><li>• 4-20 mA output signal wiring</li><li>• Slidewire feedback circuit wiring</li><li>• Digital input signals</li><li>• Communications</li><li>• 4-20 mA auxiliary output</li></ul>
3	<ul style="list-style-type: none"><li>• Low voltage alarm relay output wiring</li><li>• Low voltage wiring to solid state type control circuits</li></ul>

### Identify your wiring requirements

To determine the appropriate diagrams for wiring your recorder, refer to the model number interpretation in this section. The model number of the recorder can be found on the chart plate.

## 2.6 Input Wiring Procedures

### Wiring the recorder

Using the information contained in the model number, select the appropriate wiring diagrams from the figures listed below and wire the recorder accordingly.

Wiring Requirements	Refer to
Ferrite Filter Locations	Figure 2-11
AC Line Power	Figure 2-12
Thermocouple, RTD, Radimatic, mV, or 0–5 Vdc Inputs	Figure 2-13
4–20 mA Inputs	Figure 2-14
0–10 Vdc Inputs	Figure 2-15
4–20 mA Current Outputs or Auxiliary Outputs #2 and #3	Figure 2-16
Position Proportional Control Outputs	Figure 2-17
Relay Control Outputs – Time Proportioning	Figure 2-18
Alarm #1 and #2 Outputs and Digital Inputs	Figure 2-19
Alarm Outputs #3, #4, #5, and #6	Figure 2-20
RS485 Modbus Communications	Figure 2-21
Auxiliary Output #1	Figure 2-22

### Ferrite filter locations (CE Mark)

Inside of the enclosure, install ferrite suppression filters on all wires connected to the recorder. ©Fair-Rite Products Corp. part number 0443164151, or equivalent, shall be installed as shown in Figure 2-11, one filter for each circuit group. Cable with an outer jacket diameter larger than 6.7 mm (0.264 in.) may require the outer jacket to be removed to fit the required one turn in the filter, or the selection of a different cable.

### Shield Wiring

The shield wires of all cables, except the RS485 communications cable, should be tied to earth ground at the recorder end and to earth ground through a .0047  $\mu$ F Capacitor at the other end of the cable. An example of shield wiring to an external ground bus bar is shown in Figure 2-11.

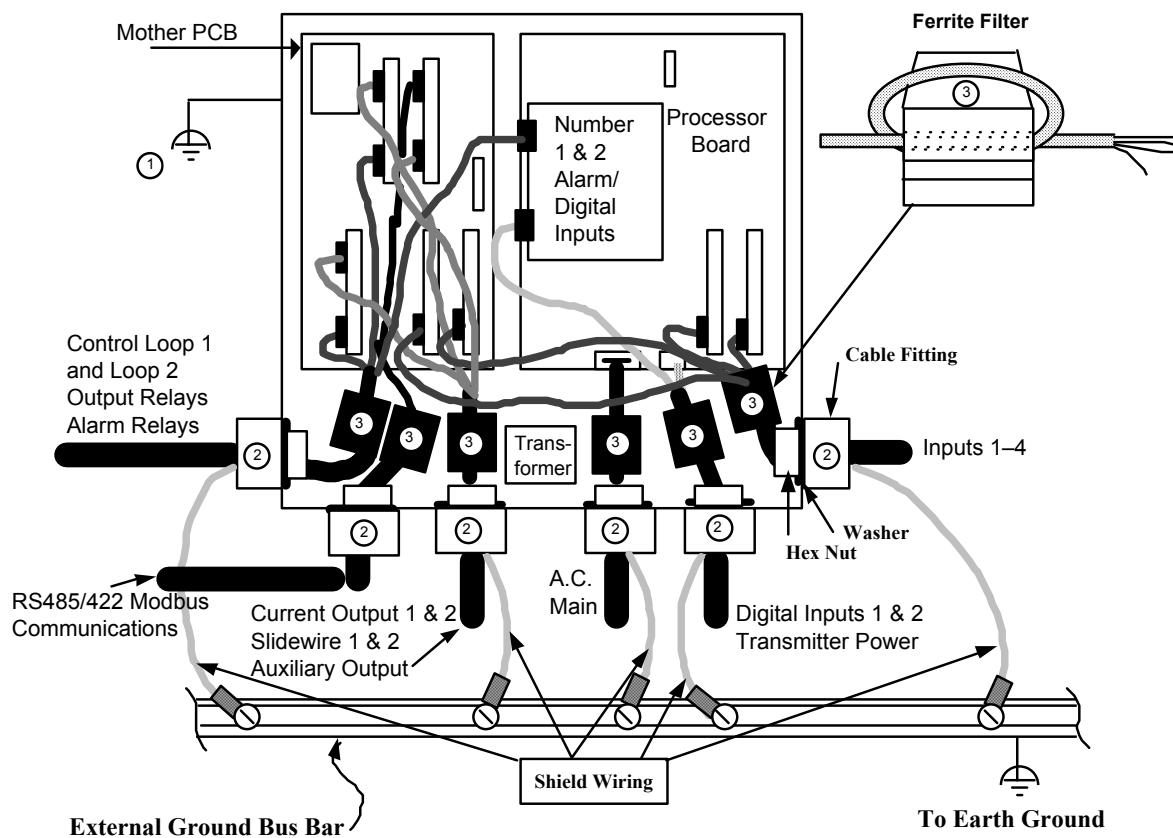

- ① Recorder Grounding, rear of case - Use 3/4 inch braided copper conductor.
- ② Use Cable fitting to support wiring and hold in place. Place the washer on the inside of the recorder between the case and the fastening nut to protect the recorder conductive case coating.
- ③ Ferrite Filter location - Cable with an outer jacket diameter larger than 6.7 mm (0.264 in.) may require the outer jacket to be removed to fit the required one turn in the filter, or the selection of a different cable.

23685

**Figure 2-11 Ferrite Filter Locations and Shield Wiring (CE Mark)**

### AC line power

Refer to Figure 2-12 and follow the procedure in Table 2-11 to connect the AC line power.



#### **WARNING**

**Be sure that the line voltage is OFF before connecting the power wires to the recorder or personal injury could result.**

This equipment is suitable for connection to 120/240 Vac, 50/60 Hz, power supply mains. It is the user's responsibility to provide a switch and non-time delay (North America), quick-acting, high breaking capacity, Type F, (Europe) 1/2 A, 250 V fuse(s) or circuit-breaker as part of the installation. The switch or circuit-breaker shall be located in close proximity to the recorder, within easy reach of the OPERATOR. The switch or circuit-breaker shall be marked as the disconnecting device for the recorder.

**Table 2-11 AC Line Power Wiring**

Step	Action
1	Open the recorder door. Loosen the captive screw in the chart plate and swing the plate out.
2	Locate connector J10 on the bottom edge of the main printed circuit board. (Refer to Figure 2-12.)
3	Remove the unwired plug from J10.
4	Run the power wires separately through second conduit from the right.
5	For CE Mark conformity, install the ferrite filter as shown in Figure 2-11.
6	Strip insulation from the end of each wire.
7	Loosen the screws in plug J10 terminals and position the plug as you would to plug it into J10.
8	<p>Insert</p> <ul style="list-style-type: none"> <li>• the <b>green</b> wire (G) into the first screw clamp from the right,</li> <li>• the <b>white</b> wire (L2) into the second screw clamp from the right, and</li> <li>• the <b>black</b> wire (L1) into the third screw clamp from the right.</li> </ul> <p>Tighten the screws to secure the wires.</p> <p><b>CAUTION</b> To avoid damaging the recorder, be sure that you install the power wires into the correct screw clamps. Make sure the fuse block is installed properly for the given supply rating — 120 Vac or 240 Vac. The fuse is in the 120 Vac location from the factory.</p>
9	<p>Make sure the fuse block is installed in the proper location. Refer to Figure 2-12 for fuse block location.</p> <ul style="list-style-type: none"> <li>• <b>120 Vac</b> – Fuse block in location <b>F2</b></li> <li>• <b>240 Vac</b> – Fuse block in location <b>F1</b></li> </ul>
10	<p>Dress the wires as slack as possible. This keeps the noise signal on these wires from bypassing built-in suppression. Also, do not bundle any low level signal wires with the power wires. Refer to Table 2-10 for permissible wire bundling.</p> <ul style="list-style-type: none"> <li>• Refer to document 51-52-05-01 for additional information concerning noise interference prevention.</li> </ul>
11	<p>Insert the wired plug into J10.</p> <p><b>WARNING</b> Input line voltage will be present on the instrument ground plane if safety ground is not attached; personal injury and product damage could result.</p>

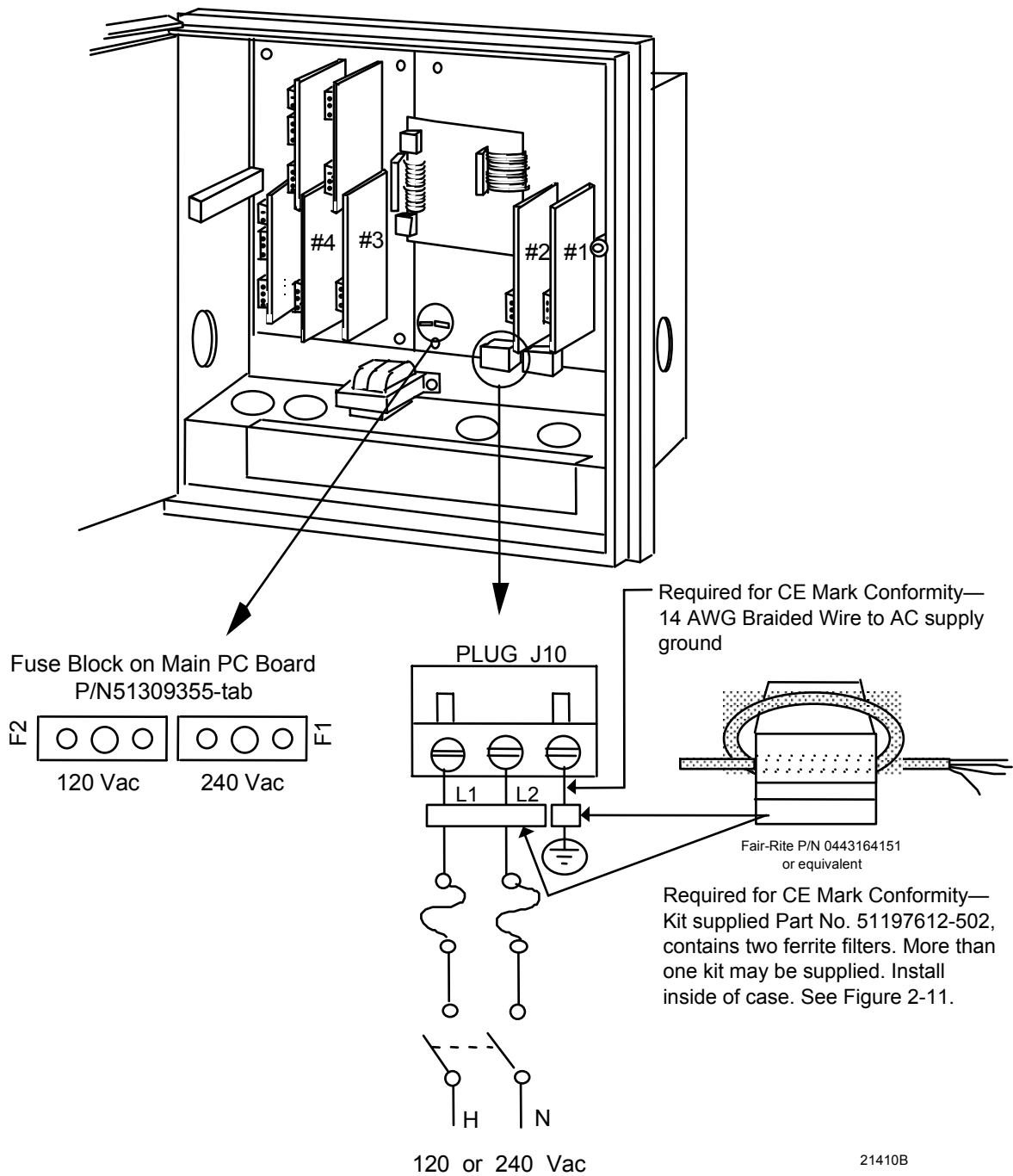

**Figure 2-12 AC Line Power Wiring**

### Thermocouple, RTD, Radiamatic, mV, or 0-5 Vdc inputs

You can wire input 1, 2, 3, or 4 for thermocouple, RTD, Radiamatic, mV, or 0-5 Vdc actuations.

The polarity for inputs #1, #2, #3, and #4 is identical.

The prerequisites are:

- Model Number - Table 1 = 1XXX, X1XX, XX1X, XXX1



#### ATTENTION

For thermocouple or RTD inputs, calibrate the recorder to achieve the stated accuracy. Refer to *Section 7 – Input Calibration*

Refer to Figure 2-13 and follow the procedure in Table 2-12 to wire Thermocouple, RTD, Radiamatic, mV, or 0–5 Vdc inputs.

**Table 2-12 Thermocouple, RTD, Radiamatic, mV, or 0–5 Vdc Input Wiring**

Step	Action
1	Open the recorder door. Loosen the captive screw in the chart plate and swing the plate out.
2	Locate connector J2 on the printed circuit board for input 1 (refer to Figure 2-13).
3	Remove the unwired plug from J2.
4	Run the input wires through the desired knockout - DO NOT bundle them with the power wires.
5	For CE Mark conformity: <ul style="list-style-type: none"> <li>• Install the ferrite filter as shown in Figure 2-11.</li> <li>• Install a .01 <math>\mu</math>F capacitor across the J2 terminals and a .0047 <math>\mu</math>F capacitor at the sensor end of the input wiring as shown in Figure 2-13.</li> </ul>
6	Locate jumper position MA/W1 and make sure the jumper is in the W1 position. (See Figure 2-13 for the location.)
7	Locate jumper position W3 and make sure the jumper is in the proper position for your input type. (See Figure 2-13 for the jumper locations.)
8	Strip insulation from the end of each wire.
9	Loosen the screws in plug J2 terminals and position the plug as you would to plug it into J2.
10	Insert the wires into the appropriate screw clamps for the applicable input type. See Figure 2-13 for specific input actuation plug wiring. Tighten the screws to secure the wires.
11	Insert the wired plug into J2.
12	Repeat steps 2 through 11 for input 2, 3, and 4 printed circuit boards as applicable.

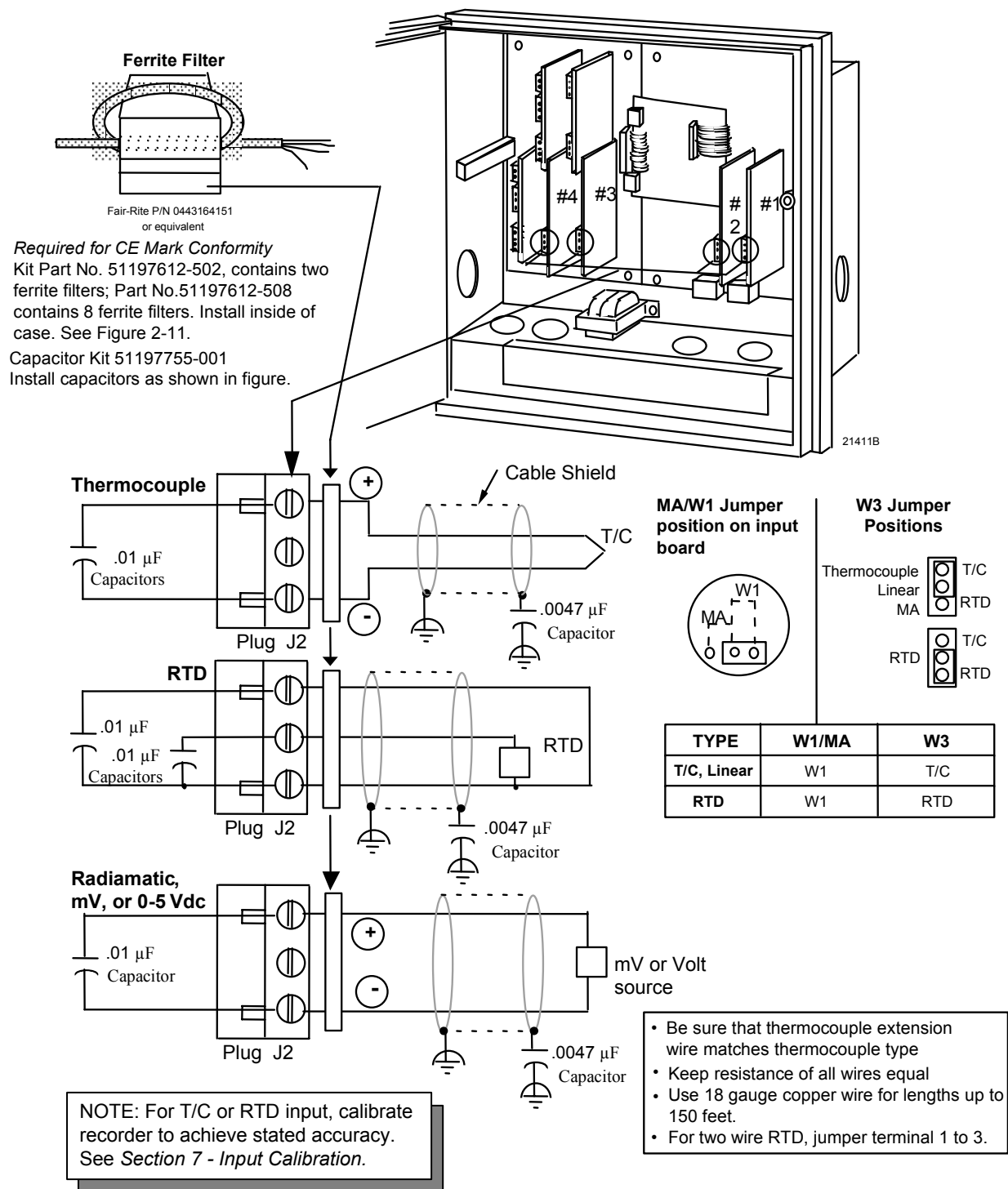

Figure 2-13 Thermocouple, RTD, Radiamatic, mV, or 0-5 Vdc Input Wiring



### 4-20 mA inputs and transmitter power

You can wire input 1, 2, 3, or 4 for 4–20 mA actuations.

The polarity for inputs #1, #2, #3, and #4 is identical.

The prerequisites are:

- Model Number - Table 1 = 1XXX, X1XX, XX1X, XXX1



#### ATTENTION

Connector J11 on the main processor printed circuit board can be used to provide 24 Vdc power to up to two field transmitters (without power) which are supplying the 4–20 mA input signals to the recorder (1.2W @ 24 Vdc = 50 mA available).

Refer to Figure 2-14 and follow the procedure in Table 2-13 to wire 4-20 mA inputs.

**Table 2-13 4-20 mA Input Wiring**

Step	Action
1	Open the recorder door. Loosen the captive screw in the chart plate and swing the plate out.
2	Be sure that the jumper MA/W1 is installed in the position labeled “MA”; this connects an internal 250-ohm resistor across the 4-20 mA input terminals on J2. (Refer to Figure 2-14 for location of jumper.)
3	Locate jumper position W3 and make sure the jumper is in the proper position for your input type (see Figure 2-14 for the location).
4	Locate connector J2 on the printed circuit board for input 1 (refer to Figure 2-14).
5	Remove the unwired plug from J2.
6	Run the input wires through the desired knockout - DO NOT bundle them with the power wires.
7	For CE Mark conformity, install the ferrite filter as shown in Figure 2-11 and the capacitors as shown in Figure 2-14.
8	Strip insulation from the end of each wire.
9	Loosen the screws in plug J2 terminals and position the plug as you would to plug it into J2.
10	<ul style="list-style-type: none"> <li>• <i>For transmitters with power:</i>  <p style="margin-left: 40px;">Insert the wires into the appropriate screw clamps and tighten the screws to secure the wires.</p> <div style="border: 1px solid black; padding: 2px; display: inline-block; margin-bottom: 5px;"><b>ATTENTION</b></div> <p style="margin-left: 40px;">The DR4500A Recorder inputs are protected from overvoltage by a protection diode. The wake-up pulse on the ST3000 may not be recognized by the transmitter due to this clamping action. It may be necessary to add 100 ohms of additional loop resistance so the transmitter and SFC can communicate.</p> </li> <li>• <i>For transmitters which require power:</i>  <p style="margin-left: 40px;">Remove the unwired plug from J11 then wire the transmitter power to J11 and the input to J2. Tighten the screws in the plugs to secure the wires.</p> </li> </ul>
11	Insert the wired plug into J2 and J11 as applicable.
12	Repeat steps 2 through 11 for input 2, 3, and 4 printed circuit boards as applicable.

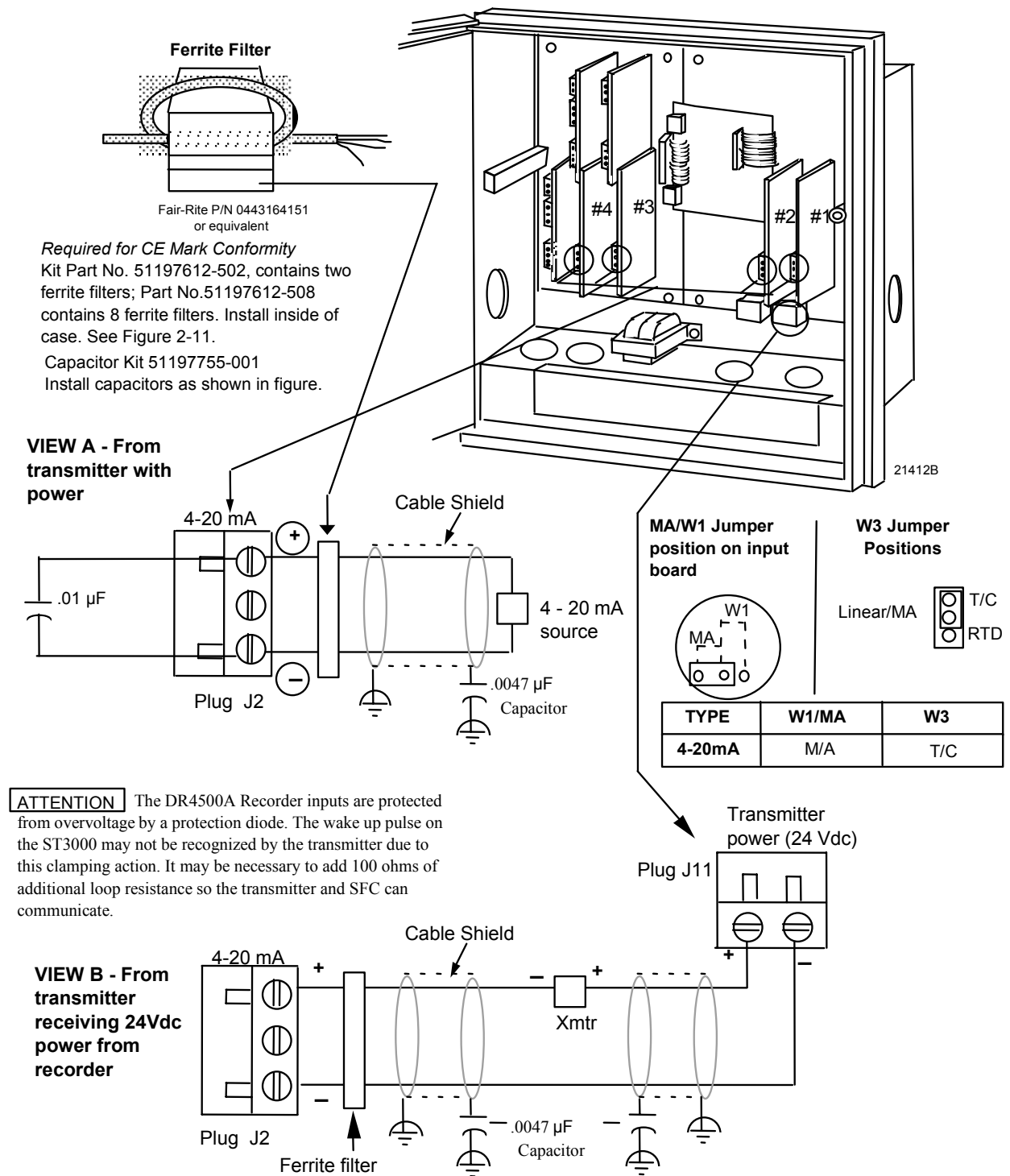

**Figure 2-14 4-20 mA Input Wiring**

### 0-10 Volt dc inputs

You can wire input 1, 2, 3, or 4 for 0–10 Volt dc actuations.

The polarity for inputs #1, #2, #3, and #4 is identical.

The prerequisites are:

- Model Number - Table 1 = 3XXX, X3XX, XX3X, XXX3



#### ATTENTION

Calibrate the recorder to achieve the stated accuracy. Refer to *Section 7 – Input Calibration*.

Refer to Figure 2-15 and follow the procedure in Table 2-14 to wire 0-10 Vdc inputs.

**Table 2-14 0-10 Volt dc Input Wiring**

Step	Action
<b>1</b>	Open the recorder door. Loosen the captive screw in the chart plate and swing the plate out.
<b>2</b>	Locate connector J2 on the printed circuit board for input 1 (refer to Figure 2-15).
<b>3</b>	Remove the unwired plug from J2 and replace it with the modified 4-screw plug from the bag of accessories supplied with the recorder.
<b>4</b>	Run the input wires through the desired knockout—DO NOT bundle them with the power wires.
<b>5</b>	For CE Mark conformity: <ul style="list-style-type: none"> <li>• Install the ferrite filter as shown in Figure 2-11.</li> <li>• Install the .01 <math>\mu</math>F capacitor and the .0047 <math>\mu</math>F capacitor as shown in Figure 2-15.</li> </ul>
<b>6</b>	Strip insulation from the end of each wire.
<b>7</b>	Loosen the screws in plug J2 terminals and position the plug as you would to plug it into J2.
<b>8</b>	Using the 30755232-002, 100K-ohm, voltage divider connector kit supplied in the bag of accessories, insert the wires into the appropriate screw clamps. Tighten the screws to secure the wires.
<b>9</b>	Install the wired plug into J2. Since J2 has only three receptacles, one of the modified plug connectors is designed to slide outside J2 when the plug is installed.
<b>10</b>	Locate jumper position W3 and make sure the jumper is in the proper position for your input type. (See Figure 2-15 for the location.)
<b>11</b>	Locate jumper position MA/W1 and make sure the jumper is in the <b>W1</b> position. (See Figure 2-15 for the location.)
<b>12</b>	Repeat steps 2 through 11 for input 2, 3, and 4 printed circuit boards as applicable.

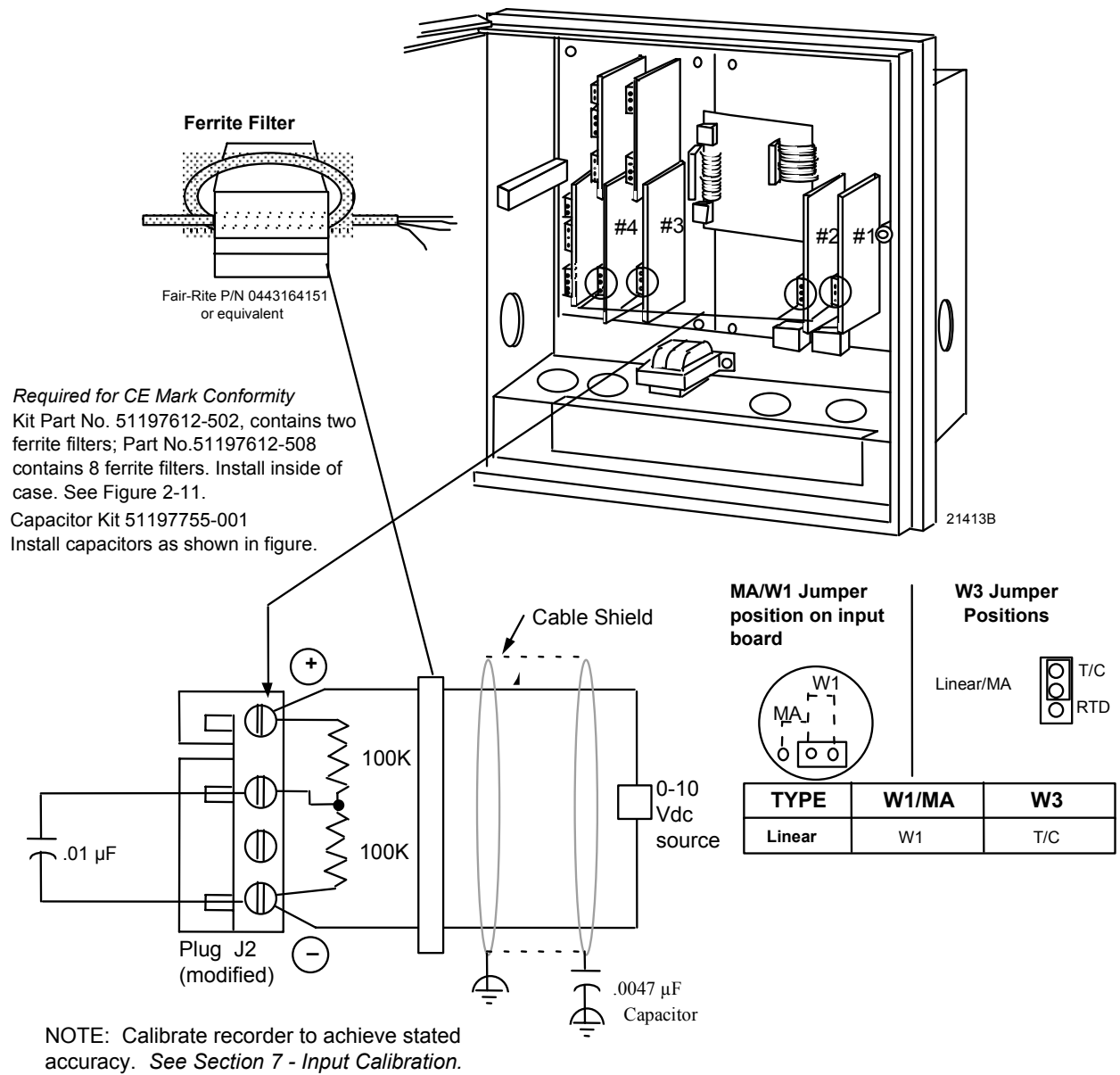

**Figure 2-15 0-10 Volt dc Input Wiring**

## 2.7 Output Wiring Procedures

### 4-20 mA control output wiring

You can wire control output 1 or 2 for 4-20 mA output.

The prerequisites are:

- Model Number - Table 2 = 10, 40, 44, 60, or 66

Refer to Figure 2-16 and follow the procedure in Table 2-15 to wire 4-20 mA control outputs.

**Table 2-15 4-20 mA Control Output Wiring**

Step	Action
1	Open the recorder door. Loosen the captive screw in the chart plate and swing the plate out.
2	Locate connector J1 near the top of the control output #1 or #2 printed circuit board (refer to Figure 2-16 for location).
3	Remove the unwired plug from J1.
4	Run the output wires through the desired knockout.
5	For CE Mark conformity, install the ferrite filter as shown in Figure 2-11 and the .0047 $\mu$ F capacitor as shown in Figure 2-16.
6	Strip insulation from the end of each wire.
7	Loosen the screws in plug J1 terminals and position the plug as you would to plug it into J1.
8	Observing the polarity, insert the wires into the appropriate screw clamps as shown (refer to Figure 2-16). Tighten the screws to secure the wires.
9	Install the wired plug into J1.
10	Locate jumper position W6/W7 on the bottom left portion of the board. Make sure W7 position is selected for 4-20 mA output.
11	Repeat steps 2 through 10 for control output #2 printed circuit board as applicable.



**TIP**

The 4-20 mA output can be used as a retransmission output if it is not used as a control output.

---

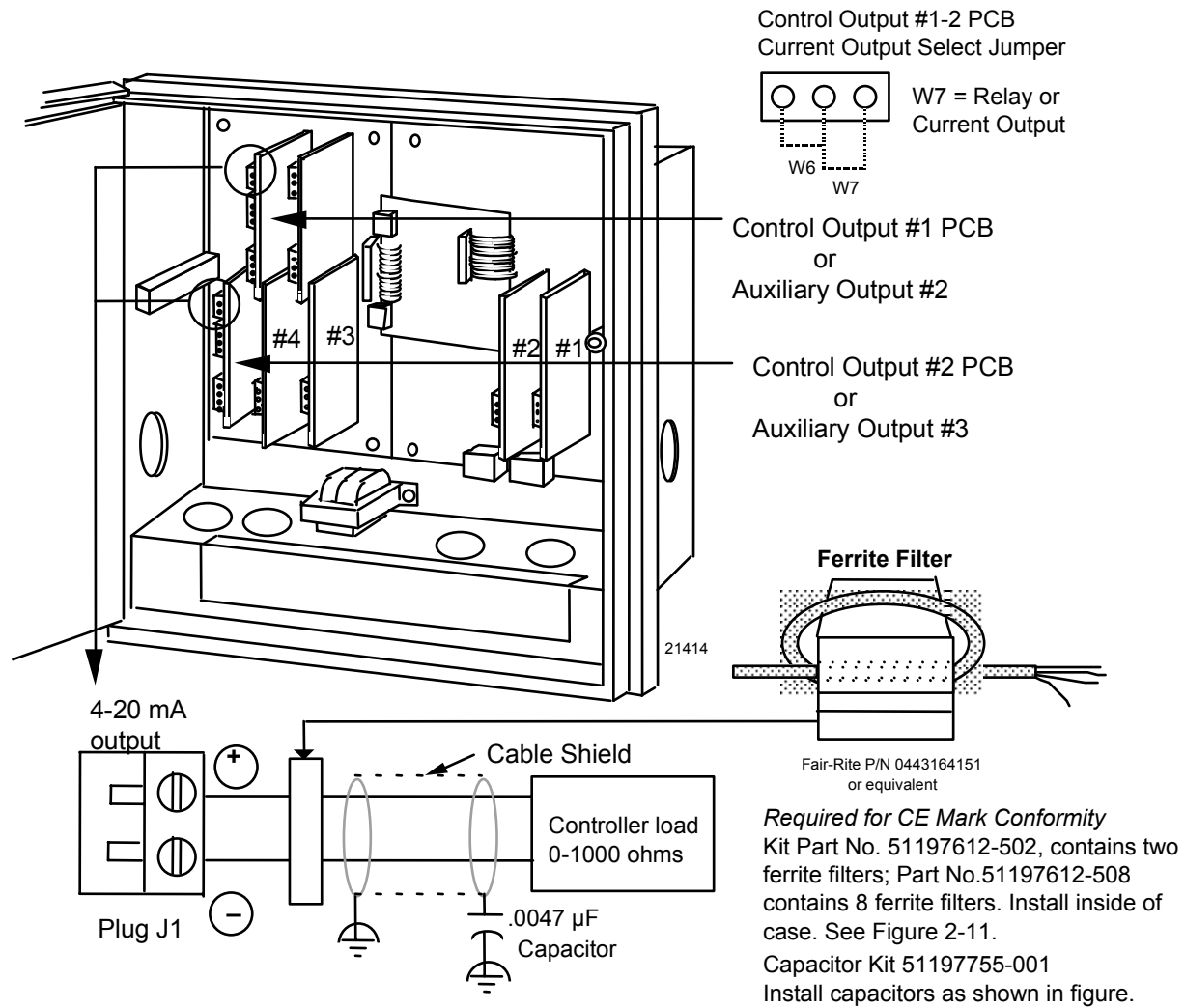

**Figure 2-16 4-20 mA Control Output Wiring (or Aux Out #2 and #3 Wiring)**

### Position proportional or 3-position step control output wiring

You can wire control output 1 or 2 for position proportional or 3 position step output.

The prerequisites are:

- Model Number Key = DR45AT
- Model Number - Table 2 = 10, 40, or 44

Refer to Figure 2-17 and follow the procedure in Table 2-16 to wire position proportional or 3 position step control outputs.



#### ATTENTION

Be sure to calibrate the position proportional control output so that the increase and decrease relays operate properly with respect to the position of the external feedback slidewire. Refer to *Section 8 - Output Calibration* in this manual.

Slidewire input is not required for 3 position step control but can be used for motor position indication.

**Table 2-16 Position Proportional Control Output Wiring**

Step	Action
1	Open the recorder door. Loosen the captive screw in the chart plate and swing the plate out.
2	Locate connector J2 and J5 on the control output #1 printed circuit board (refer to Figure 2-17 for location).
3	Locate jumper positions W2/W3 and W4/W5 below connector J5 on the printed circuit board. Remove plug-in output #1 printed circuit board for better access to the jumpers. Be sure to tag and remove all the plug connections to the printed circuit board before removing it. Position the jumpers as shown in Figure 2-17 for desired relay contact action. Locate jumper position W6/W7 on the bottom left portion of the board. Make sure position W6 is selected for position proportioning, then reinstall the printed circuit board.
4	Run the feedback slidewire (not required for 3 position step) and motor drive wires through the desired knockouts.
5	For CE Mark conformity: <ul style="list-style-type: none"> <li>• install the ferrite filter as shown in Figure 2-11</li> <li>• install the shield capacitors as shown in Figure 2-17.</li> </ul>
6	Strip insulation from the end of each wire.
7	Loosen the screws in plug J2 terminals and position the plug as you would to plug it into J2.
8	Insert the wires from the motor's feedback slidewire into the appropriate screw clamps as shown (refer to Figure 2-17). Tighten the screws to secure the wires.
9	Loosen the screws in plug J5 terminals and position the plug as you would to plug it into J5.
10	Insert the wires for the motor into the appropriate screw clamps as shown (refer to Figure 2-17). Tighten the screws to secure the wires.
11	Install the wired plug into J2 and J5, as applicable.
12	Repeat steps 2 through 11 for Control Output #2 printed circuit board as applicable.

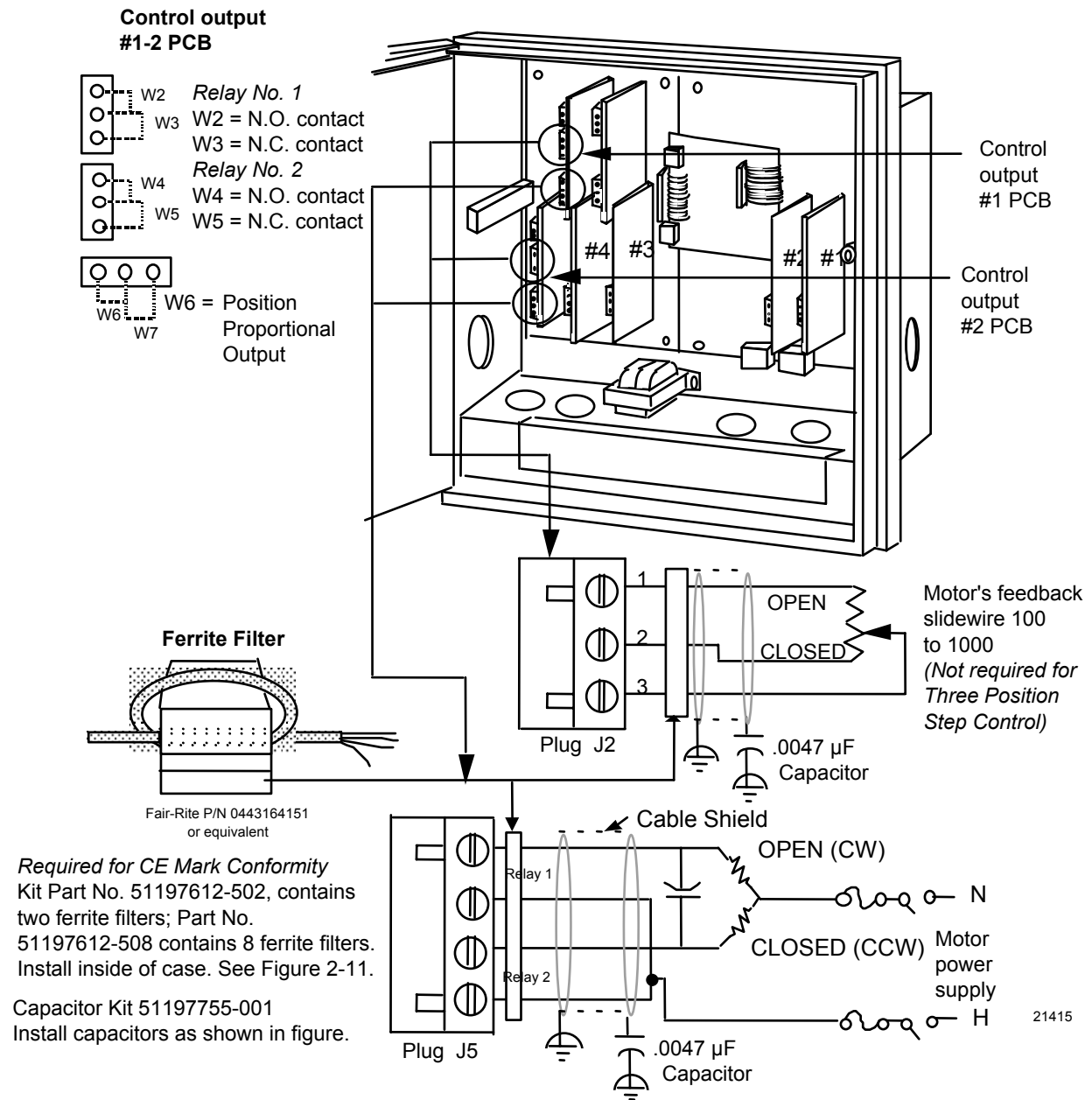

**Figure 2-17 Position Proportional Control Output or Three Position Step Wiring**



### Relay control output wiring

You can wire control output 1 or 2 for relay output including Time proportional and 3 position step applications.

The prerequisites are:

- Model Number - Table 2 = 10, 40, 60, 11, 44, 66

Refer to Figure 2-18 and follow the procedure in Table 2-17 to wire relay control outputs.



#### ATTENTION

Relay #2 is used for time proportional control. Relay 2 can also be used for 3 position step control (see Figure 2-17).

**Table 2-17 Relay Control Output Wiring**

Step	Action
1	Open the recorder door. Loosen the captive screw in the chart plate and swing the plate out.
2	Locate connector J5 on the control output #1 printed circuit board (refer to Figure 2-18 for location).
3	Remove the unwired plug from J5.
4	Locate jumper positions W2/W3 and W4/W5 below connector J5 on the printed circuit board. Remove plug-in output #1 printed circuit board for better access to the jumpers. Be sure to tag and remove all the plug connections to the printed circuit board before removing it. Position the jumpers as shown in Figure 2-18 for desired relay contact action. Locate jumper position W6/W7 on the bottom left portion of the board. Make sure W7 position is selected for relay control output, then reinstall the printed circuit board.
5	Run the relay load wires through the desired knockouts.
6	For CE Mark conformity: - install the ferrite filter as shown in Figure 2-11. - install the shield capacitor as shown in Figure 2-18.
7	Strip insulation from the end of each wire.
8	Loosen the screws in plug J5 terminals and position the plug as you would to plug it into J5.
9	Insert the relay wires and relay power into the appropriate screw clamps for single or duplex action as shown (refer to Figure 2-18); tighten the screws to secure the wires.
10	Install the wired plug into J5.
11	Repeat steps 2 through 10 for control output #2 printed circuit board as applicable.

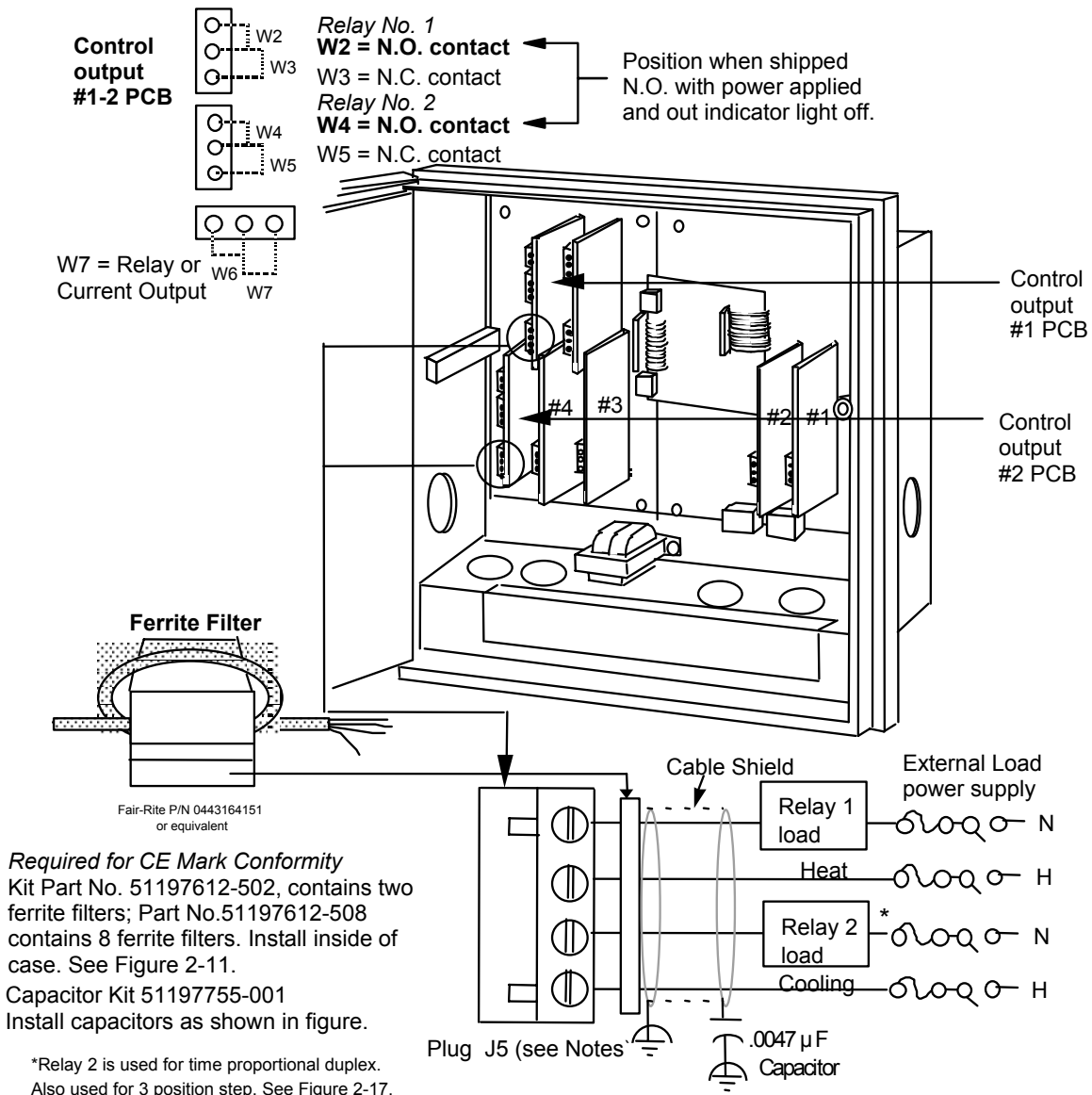

**Notes:**

1. J5 terminals 2 and 4 are the non-switched connections to an SPST relay. Selectable for normally open or normally closed as required.
2. This relay supplies a dry contact closure. User must supply appropriate power connections for his external device.
3. This relay has a resistive load rating of 5A @ 120 Vac  
Load calculation example:

$$\frac{\text{Supply voltage (for example: 115 Vac)}}{\text{Resistance of customer controlled device}} = \text{number less than 5 amps}$$

21416

**Figure 2-18 Relay Control Output Wiring**

## 2.8 Option Wiring Procedures

### Alarm output and digital input wiring

You can wire #1 and #2 Alarm Outputs and Digital Inputs.

The prerequisites are:

- Model Number - Table 3 = XX1

Refer to Figure 2-19 and follow the procedure in Table 2-18 to wire alarm outputs or digital inputs.

The alarm output is a dry contact closure.

**Table 2-18 Alarm Output or Digital Input Wiring**

Step	Action
1	Open the recorder door. Loosen the captive screw in the chart plate and swing the plate out.
2	Locate connector J3 and J4 on the alarm output/digital input printed circuit board (refer to Figure 2-19 for location).
3	Remove the unwired plug from J3.
4	Run the digital input wires through the desired knockout.
5	For CE Mark conformity, install the ferrite filter as shown in Figure 2-11.
6	Strip insulation from the end of each wire.
7	Loosen the screws in plug J3 terminals and position the plug as you would to plug it into J3.
8	Insert the wires for the digital inputs into the appropriate screw clamps as shown (refer to Figure 2-19). Note that you can wire the contacts in an <b>and/or</b> fashion, so that <b>both</b> contacts <b>or</b> either contact initiates the configured action. Tighten the screws to secure the wires.
9	Install the wired plug into J3.
10	Remove the unwired plug from J4.
11	Run the alarm output wires through the desired knockout.
12	For CE Mark conformity: <ul style="list-style-type: none"> <li>• install the ferrite filter as shown in Figure 2-11</li> <li>• install the shield capacitors as shown in Figure 2-19.</li> </ul>
13	Strip insulation from the end of each wire.
14	Loosen the screws in plug J4 terminals and position the plug as you would to plug it into J4.
15	Insert the wires for the alarm devices into the appropriate screw clamps as shown (refer to Figure 2-19). Tighten the screws to secure the wires.
16	Locate the jumper positions W1/W2 and W3/W4 on the printed circuit board. Reposition the jumpers as shown in Figure 2-19 for the desired relay control action. The recorder is shipped with the W1 and W3 in N.C. positions.
17	Install the wired plug into J4.

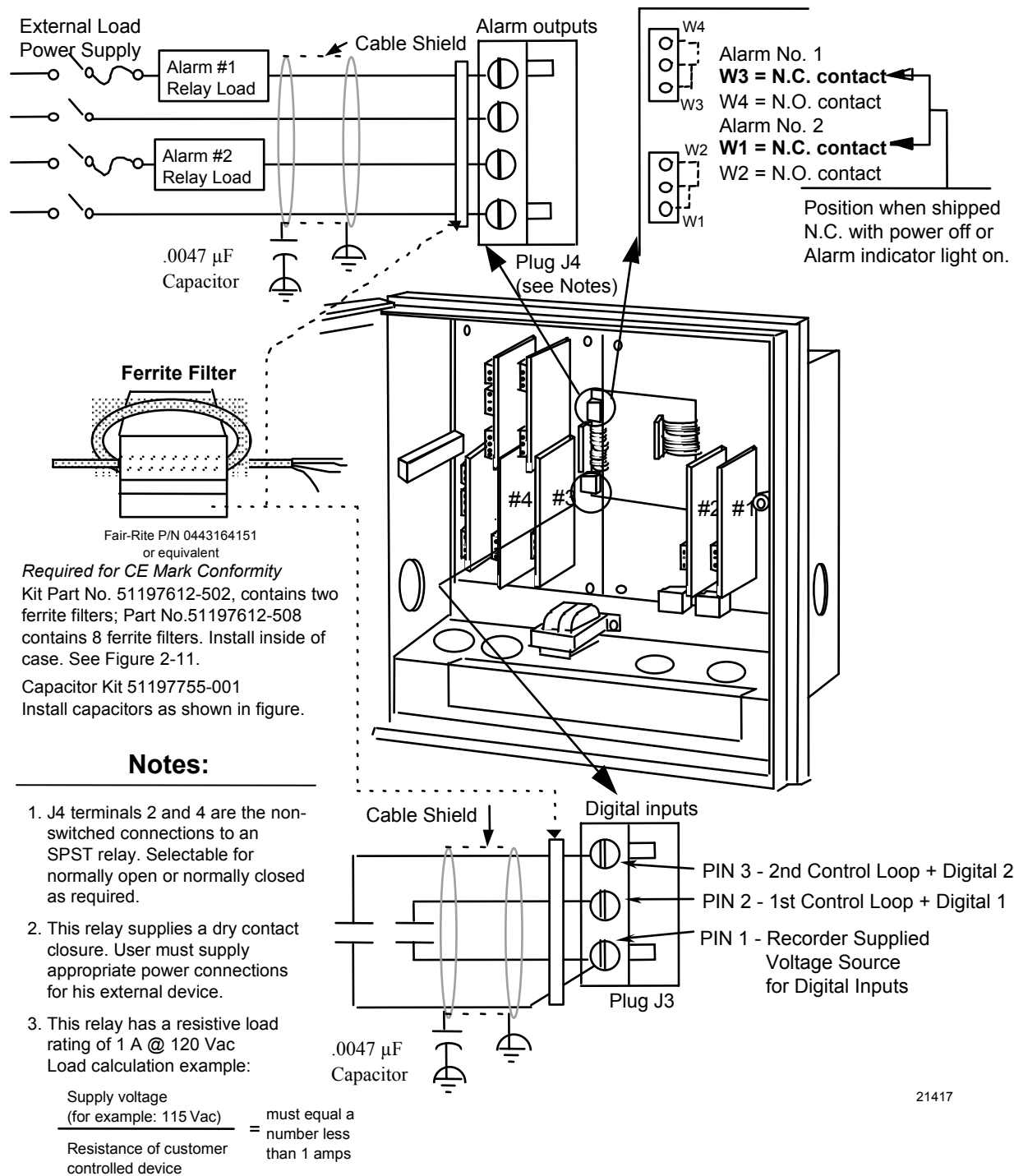

21417

Figure 2-19 Alarm Output or Digital Input Wiring

### Additional alarm wiring information

The DR4500 has the ability to provide for Alarm outputs 3, 4, 5, and 6.

Follow the procedures listed below to wire No. 3 and No. 4 Alarm Outputs and No. 5 and No. 6 Alarm Outputs.

### Alarms 3 and 4 output wiring

You can wire #3 and #4 Alarm Outputs.

The prerequisites are:

- Model Number - Model Table 2 = 1X, 4X, 6X\*

*\*If control output is 4-20 mA, then the relays on the control card are available for use as alarms on all models except DR45AH/AS/AP models.*

Refer to Figure 2-20 and follow the procedure in Table 2-19 to wire Alarm 3 and Alarm 4 outputs.

**Table 2-19 Alarm 3 and Alarm 4 Output Wiring**

Step	Action
1	Open the recorder door. Loosen the captive screw in the chart plate and swing the plate out.
2	Locate connector J5 on the 4-20 mA control output printed circuit board to wire relays #3 and #4. Refer to Figure 2-20 for location.
3	Remove the unwired plug from J5.
4	Locate jumper position W2/W3 and W4/W5 below connector J5 on the printed circuit board. Note that you may want to remove the plug-in output printed circuit board for better access to jumpers. Be sure to tag and remove all the plug connections to the printed circuit boards before removing it. Position the jumpers as shown for the desired relay contact action and reinstall the printed circuit board.
5	Run the alarm output wires through the desired knockout.
6	For CE Mark conformity: <ul style="list-style-type: none"> <li>• install the ferrite filter as shown in Figure 2-11</li> <li>• install the capacitors as shown in Figure 2-20</li> </ul>
7	Strip insulation from the end of each wire.
8	Loosen the screws in plug J5 terminals and position the plug as you would to plug it into J5.
9	Insert the wires for the alarm devices into the appropriate screw clamps as shown. Refer to Figure 2-20. Tighten the screws to secure the wires.
10	Install the wired plug into J5.

### **Alarms 5 and 6 output wiring**

You can wire #5 and #6 Alarm outputs.

The prerequisites are:

- Model Number - Model Table 2 = X1, X4, X6\*

*\*If control output is 4-20 mA, then the relays on the control card are available for use as alarms on all models except DR45AH/AS/AP models.*

Refer to Figure 2-20 and follow the procedure in Table 2-20 to wire Alarm 5 and Alarm 6 outputs.

**Table 2-20 Alarm 5 and Alarm 6 Output Wiring**

<b>Step</b>	<b>Action</b>
<b>1</b>	Open the recorder door. Loosen the captive screw in the chart plate and swing the plate out.
<b>2</b>	Locate connector J5 on the 4-20 mA control output printed circuit board to wire relays #5 and #6. Refer to Figure 2-20 for location.
<b>3</b>	Remove the unwired plug from J5.
<b>4</b>	Locate jumper position W2/W3 and W4/W5 below connector J5 on the printed circuit board. Note that you may want to remove the plug-in output printed circuit board for better access to jumpers. Be sure to tag and remove all the plug connections to the printed circuit boards before removing it. Position the jumpers as shown for the desired relay contact action and reinstall the printed circuit board.
<b>5</b>	Run the Alarm output wires through the desired knockout.
<b>6</b>	For CE Mark conformity: <ul style="list-style-type: none"><li>• install the ferrite filter as shown in Figure 2-11</li><li>• install the capacitors as shown in Figure 2-20</li></ul>
<b>7</b>	Strip insulation from the end of each wire.
<b>8</b>	Loosen the screws in plug J5 terminals and position the plug as you would to plug it into J5.
<b>9</b>	Insert the wires for the alarm devices into the appropriate screw clamps as shown. Refer to Figure 2-20. Tighten the screws to secure the wires.
<b>10</b>	Install the wired plug into J5.

**Wiring for alarm outputs #3, 4, 5, and 6**

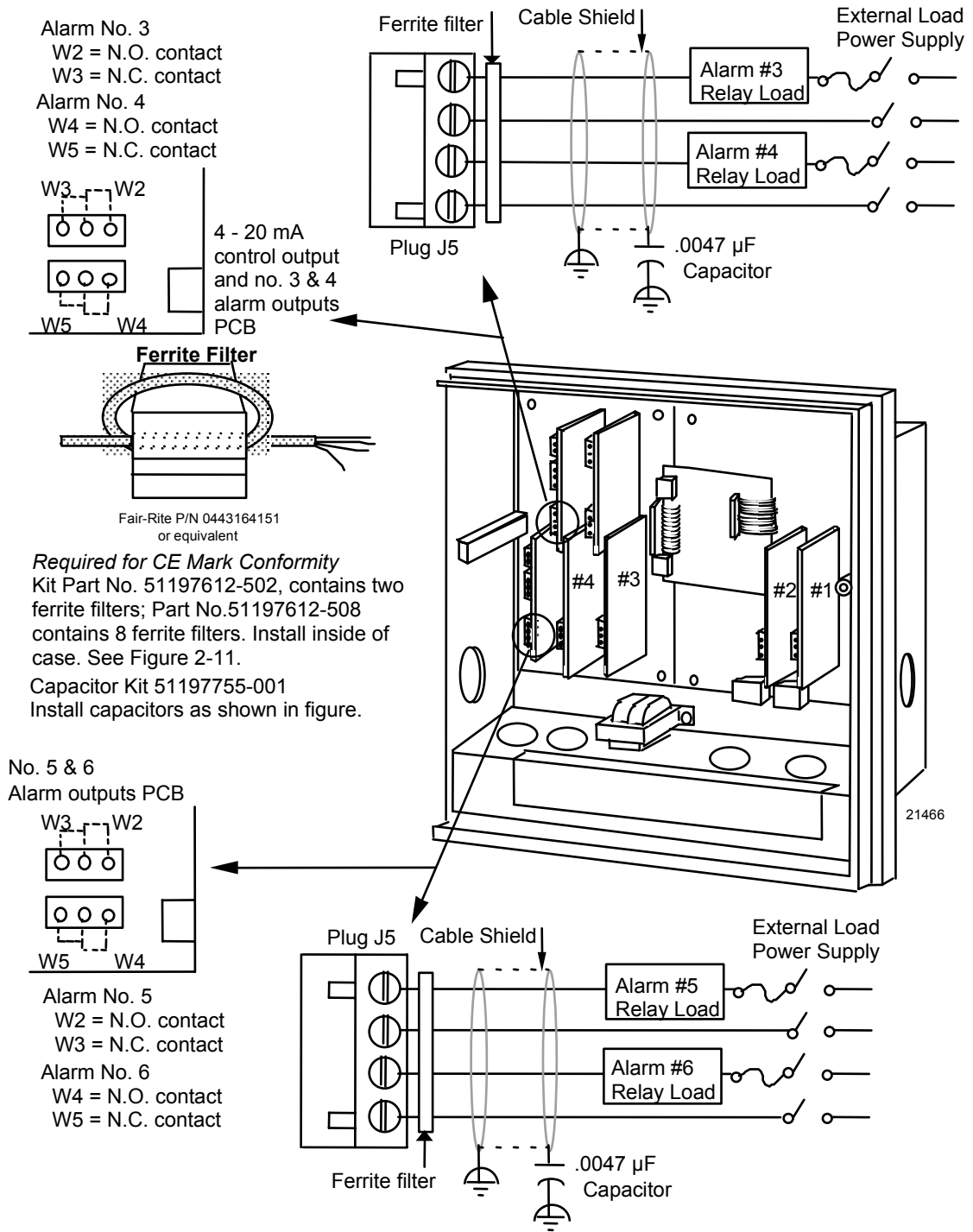

**Figure 2-20 Alarm outputs #3, 4, 5, and 6 wiring**

### RS485 Modbus communications wiring

RS485 Modbus Communications is an option available on the DR4500A recorder.

The prerequisites are:

- Model Key Number - All models except DR45AH/AP/AS
- Model Number - Table 3 = 3XX or 4XX

Refer to Figure 2-21 and follow the procedure in Table 2-21 to wire the RS485 Modbus communications option.

**Table 2-21 RS485 Modbus Communications Wiring**

Step	Action
1	Open the recorder door. Loosen the captive screw in the chart plate and swing the plate out.
2	Locate connector J3 on the RS485 Modbus communications option printed circuit board (refer to Figure 2-21 for location).
3	Remove the unwired plug from J3.
4	Run the communications option wires through the desired knockout.
5	For CE Mark conformity <ul style="list-style-type: none"><li>• Install the ferrite filter as shown in Figure 2-11.</li><li>• Refer to Figure 2-21 for shield information.</li></ul>
6	Strip insulation from the end of each wire.
7	Loosen the screws in plug J3 terminals and position the plug as you would to plug it into J3.
8	Insert the wires for the communications option into the appropriate screw clamps as shown (refer to Figure 2-22). Tighten the screws to secure the wires.
9	Install the wired plug J3 into J3 connector on the communications board.



#### REFERENCE

Refer to documents 51-52-25-66 and 51-52-25-69 for a complete description of RS485 Modbus Communications Option.

---



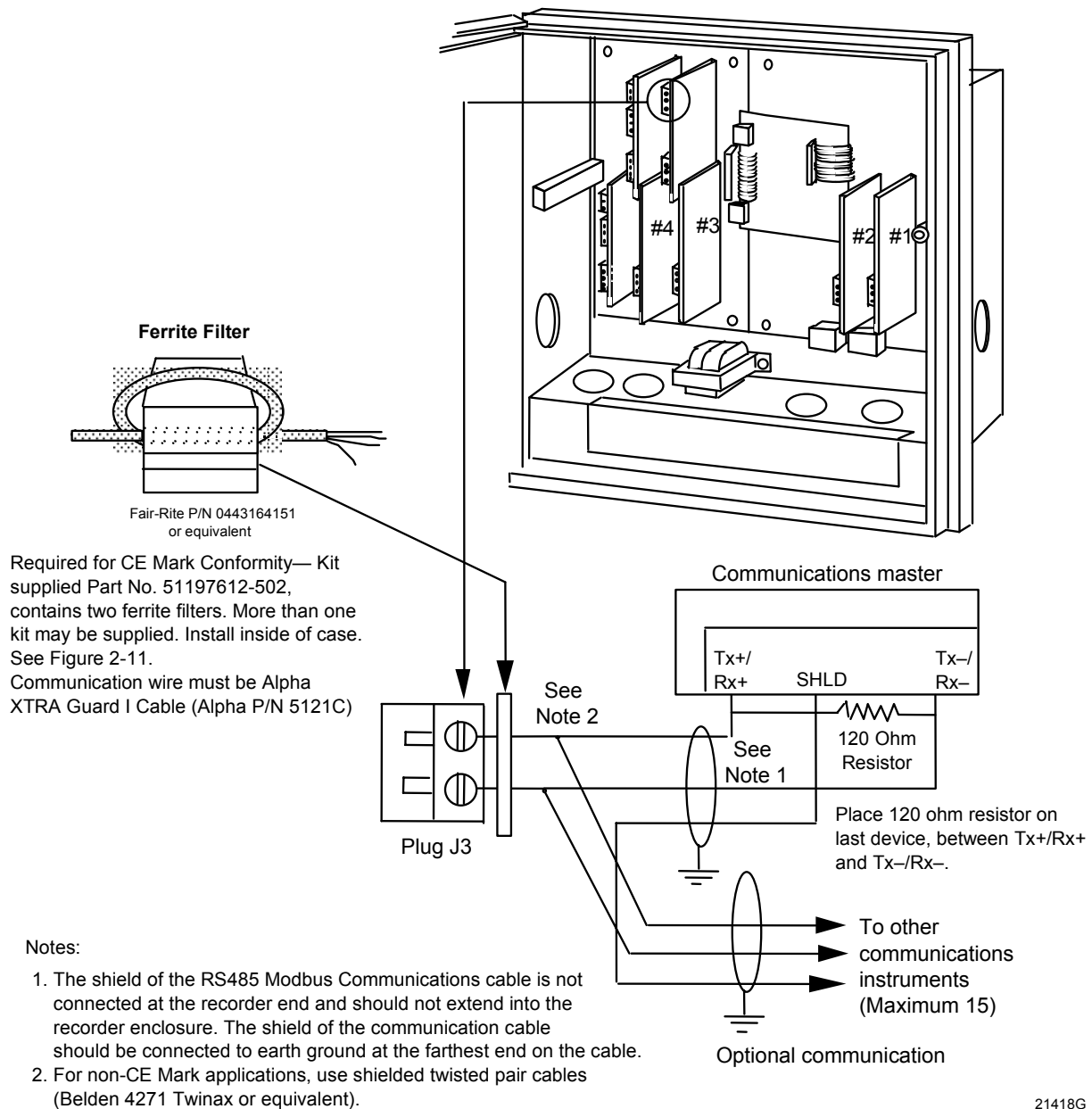

21418G

**Figure 2-21 RS485 Modbus Communications Wiring**

### 4-20 mA auxiliary output wiring

You can wire an auxiliary output for 4–20 mA.

The prerequisites are:

- Model Number - Table 3 = 1XX or 4XX

Refer to Figure 2-22 and follow the procedure in Table 2-22 to wire 4–20 mA auxiliary output.

**Table 2-22 4-20 mA Auxiliary Output Wiring**

Step	Action
1	Open the recorder door. Loosen the captive screw in the chart plate and swing the plate out.
2	Locate connector J2 near the bottom of the auxiliary output printed circuit board (refer to Figure 2-22 for location).
3	Remove the unwired plug from J2.
4	Run the output wires through the desired knockout.
5	For CE Mark conformity, install the ferrite filter as shown in Figure 2-11.
6	Strip insulation from the end of each wire.
7	Loosen the screws in plug J2 terminals and position the plug as you would to plug it into J2.
8	Observing the polarity, insert the wires into the appropriate screw clamps as shown (refer to Figure 2-22). Tighten the screws to secure the wires.
9	Install the wired plug into J2.



#### ATTENTION

Be sure that the 4-20 mA auxiliary output is aligned. Refer to *Subsection 8.4 Auxiliary Output Calibration*.

---



#### TIP

The 4-20 mA output on the control output board can also be set up for an Auxiliary retransmission output if it is not being used for a control output. This requires model selection option Table II = 10, 40, 44, 60, 66.

---



#### TIP

Auxiliary output 2 and Auxiliary output 3 use Control current output 1 and Control current output 2 if Control “OUT ALG” is not set to “CURRENT”. Refer to *Figure 2-16 for Aux Out #2 and #3 wiring*.

---

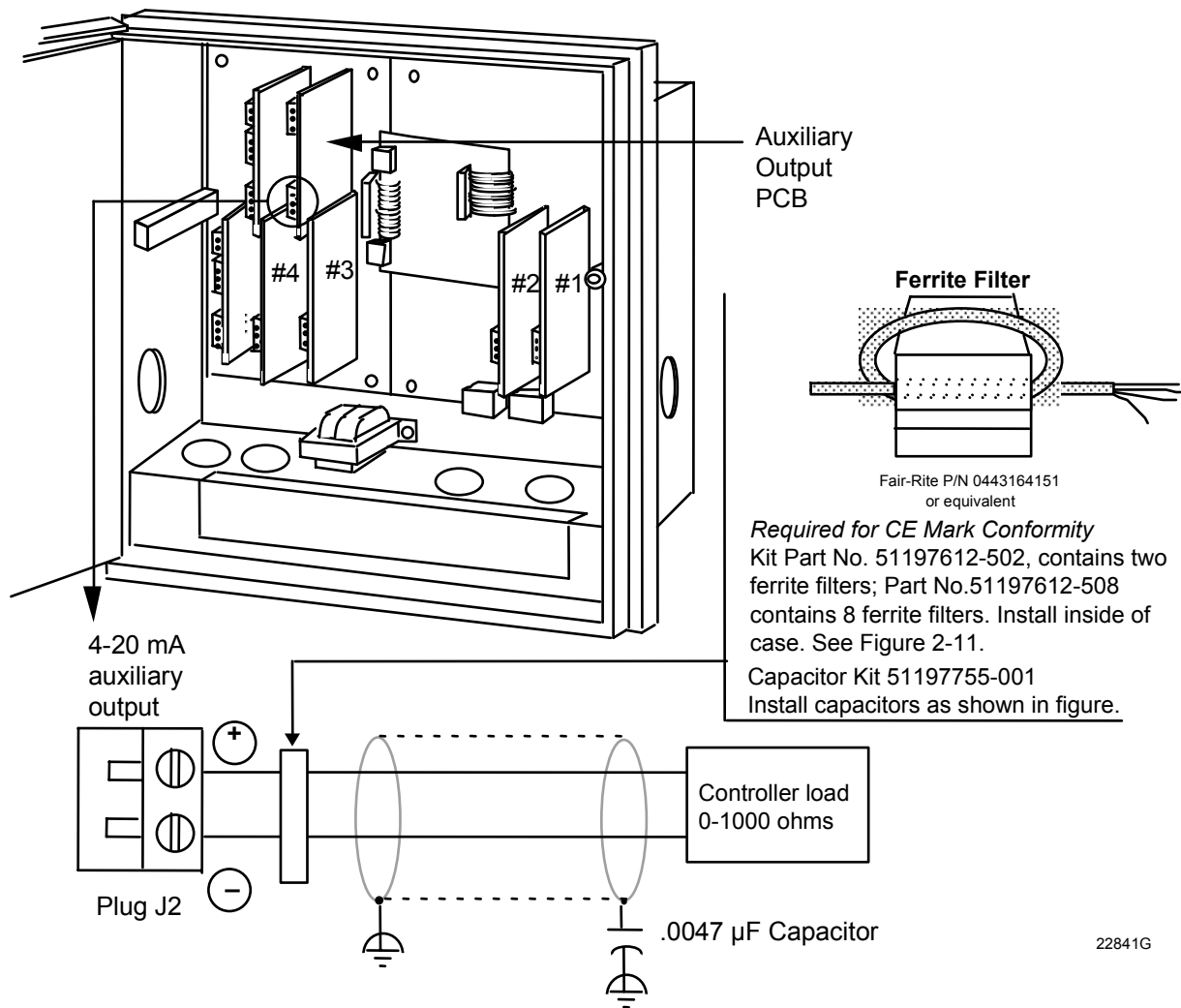

Figure 2-22 4-20 mA Auxiliary Output #1 Wiring



**ATTENTION**

Refer to Figure 2-16 for Auxiliary Output 2 and Auxiliary Output 3 wiring.

## 2.9 Lockout Switch Configuration

### Introduction

The configuration can be locked using S1 switch located next to the microprocessor U17 on the main printed circuit board.

### Restrictions based on lockout switch position

Figure 2-23 shows the location of the S1 lockout switch on the main printed circuit board.

When the lockout switch is OFF (**Down**—Configure):

- You can view and change all applicable operating parameters as described in *Section 4 – Configuration Parameter Definitions*.

When the lockout switch is ON (**Up**—Locked):

- Most parameters for the recorder are locked and the parameters may not be changed except for Tuning 1 and Tuning 2 parameters and adjustments to time/date/day/year.

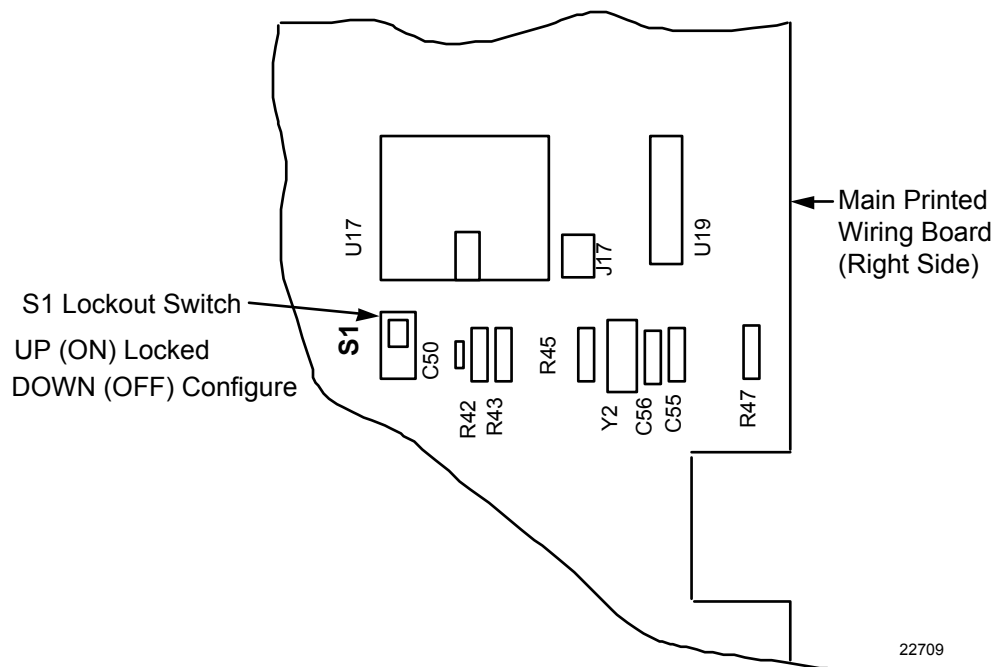

**Figure 2-23 S1 Lockout Switch Location**



### ATTENTION

Lockout can also be configured under set up group "LOCKOUT". See *Subsection 3.21*.

This feature also includes the special screw and plate that provide the lead seal capability for sealing the chart plate. This feature is normally used with DR45AH model recorders.

---

## 3. Configuration

### 3.1 Overview

#### Introduction

Configuration is a dedicated operation where you use straightforward keystroke sequences to select and establish (configure) pertinent control data best suited for your application.

#### What's in this section?

The table below lists the topics that are covered in this section.

	<b>Topic</b>	<b>See Page</b>
3.1	Overview	55
3.2	Configuration Prompts	57
3.3	How to Get Started	60
3.4	Configuration Tips	61
3.5	Configuration Procedure	62
3.6	Input Set Up Group	64
3.7	Pen Set Up Group	66
3.8	Chart Set Up Group	67
3.9	Time Set Up Group	69
3.10	Totalizer Set Up Group	70
3.11	Input Algorithm Set Up Group	72
3.12	Control Set Up Group	73
3.13	Tuning Parameters Set Up Group	75
3.14	SP Ramp Set Up Group	76
3.15	Timer Set Up Group	77
3.16	Alarms Set Up Group	78
3.17	Auxiliary Output Set Up Group	80
3.18	Modbus Communications Set Up Group	81
3.19	Options Set Up Group	82
3.20	Event Message	83
3.21	Lockout Set Up Group	86
3.22	Adjust Printing	87
3.23	Configuration Record Sheet	88

## Prompts

To assist you in the configuration process, there are prompts that appear in the upper and lower displays. These prompts let you know what group of configuration data (set up prompts) you are working with and also the specific parameters (function prompts) associated with each group.

Figure 3-1 shows an overview of the prompt hierarchy.

## 3.2 Configuration Prompts

### Diagram: prompt hierarchy

Figure 3-1 shows an overview of the DR4500A Set Up prompts and their associated Function prompt - read from left to right.

Figure 3-1 DR4500A Prompt Hierarchy

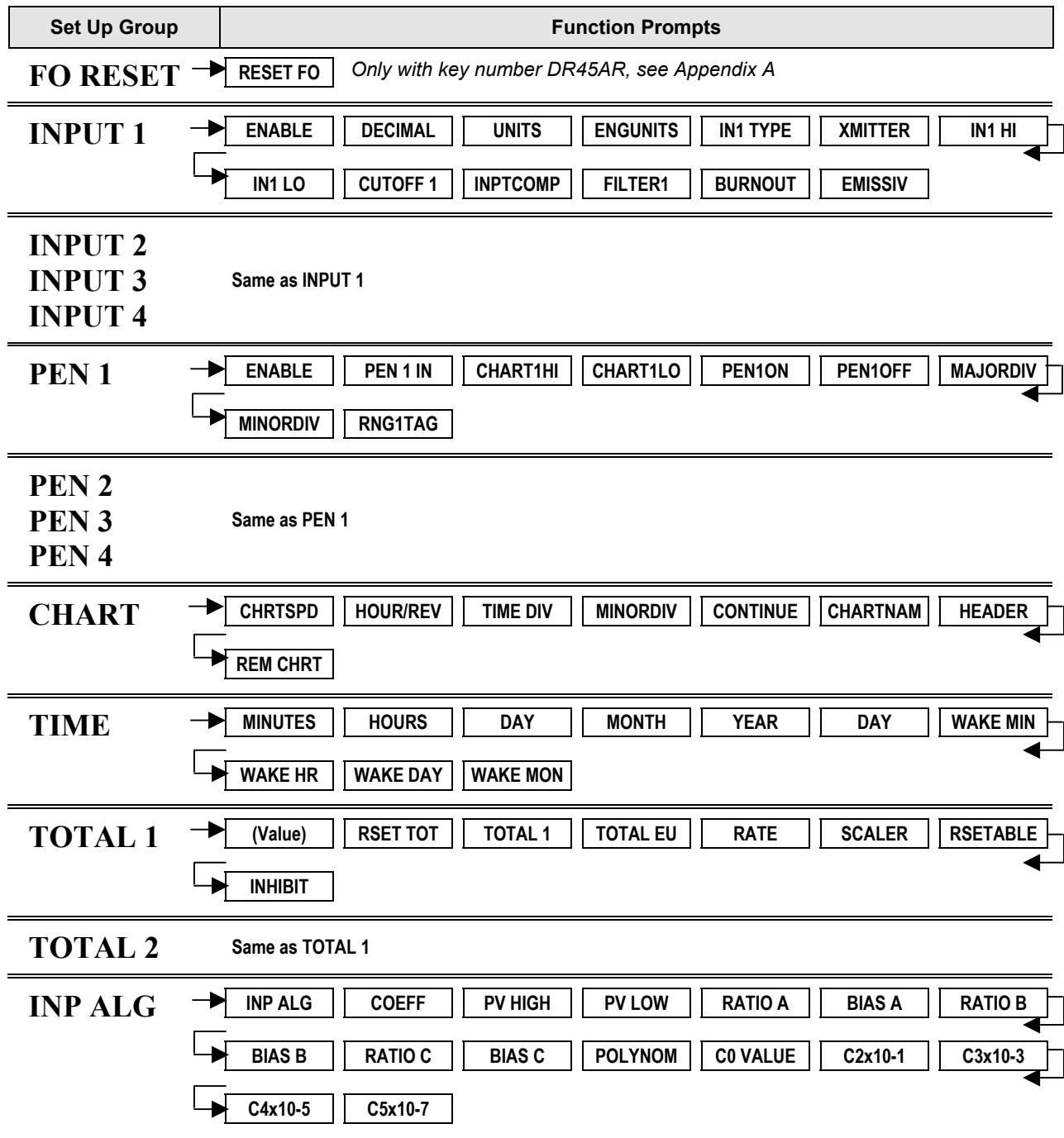

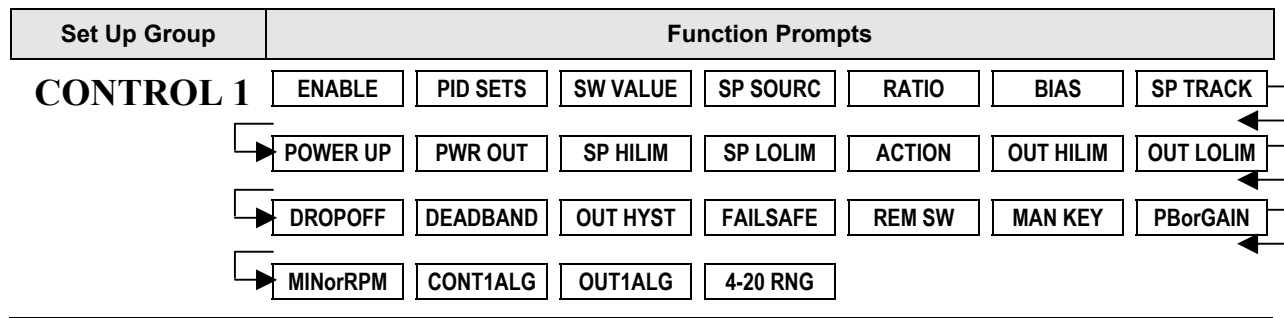

**CONTROL 2** Same as CONTROL 1

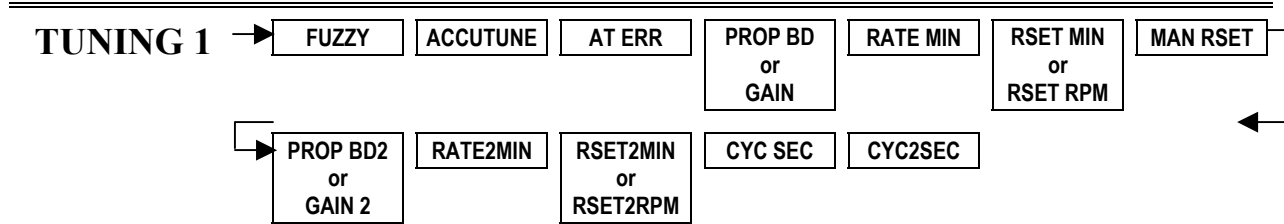

**TUNING 2** Same as TUNING 1

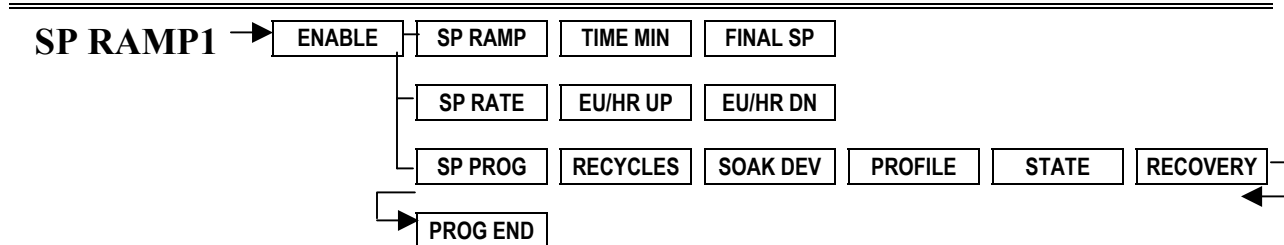

**SP RAMP2** Same as SP RAMP1

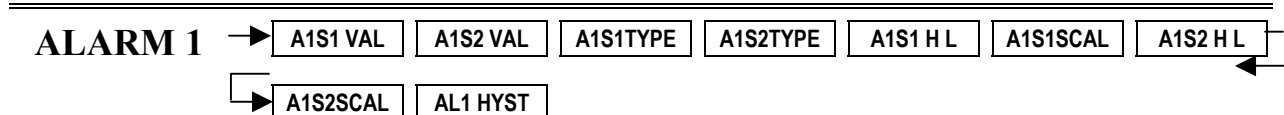
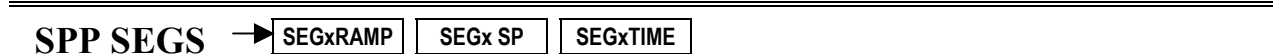

**ALARM 2**

**ALARM 3**

**ALARM 4** Same as ALARM 1

**ALARM 5**

**ALARM 6**



Set Up Group	Function Prompts								
<b>AUX OUT</b>	→	AUX OUT	4 mA VAL	20mA VAL	AUX OUT 2	4 mA VAL	20mA VAL	AUX OUT 3	
		↳	4mA VAL	20 mA VAL				←	
<b>COMM</b>	→	ComSTATE	Com ADDR	BAUD	XMT DLAY	DBL BYTE			
<b>OPTIONS</b>	→	REJ FREQ	HF REJ	RELHUMID	ATMPRES	DEVIATION	DEVSETPT	SCROLL	
		↳	GRANDTOT	<i>If key number is DR45AR, see Appendix A for Fo calculation prompts.</i>					
<b>EVNT MSG</b>	→	EVENT 1	MESSAGE1	POSITION1	EVENT 2	MESSAGE2	POSITION2	EVENT 3	
		↳	MESSAGE3	POSITION3	EVENT 4	MESSAGE4	POSITION4	EVENT 5	MESSAGE5
		↳	POSITION5	EVENT 6	MESSAGE6	POSITION6			
<b>LOCKOUT</b>	→	PASSWORD	LOCKOUT	CHANGE					
<b>ADJUST</b>	→	TRACE LN	GRID LN	PEN TYPE					
<b>CALIB</b>	For field calibration—see Calibration section of manual								
<b>STATUS</b>	→	VERSION	FAILSAFE*	RAM TEST	CONFTEST	CAL TEST	COMMTEST	FACT CRC	
		↳	BATTERY	<i>*Displayed on test failure only</i>					←

## 3.3 How To Get Started

### Read the configuration tips

Read *Subsection 3.4 Configuration Tips* which will help you to easily and quickly configure your recorder.

### Read configuration procedure

Read *Subsection 3.5 Configuration Procedure* which tells you how to access the Set Up groups, and the function parameters within each of these groups that are shown in the Prompt Hierarchy in Figure 3-1.

### Set Up groups

The Set Up groups and function parameters are listed in the order of their appearance. The list includes the name of the prompt, the range of setting or selections available, and the factory setting. It allows you to quickly find a parameter and obtain the available range or selection you require.

### Parameter explanations or definitions

If you need a detailed explanation of any prompt listed, refer to *Section 4 – Configuration Parameter Definitions*. This section lists the set up and function prompts, the selections or range of settings that you can make for each, plus a detailed explanation or definition of each parameter.

### Configuration record sheet

Located in *Subsection 3.23* is a *Configuration Record Sheet*. When you make your configuration selections, record them on this sheet. Then you will have a record of how the recorder was configured.

Set up the recorder in this order:

- Inputs (Display will be correct)
- Pens (Trace will agree with display)
- Chart
- Alarms
- Control
- Tuning
- Other functions as needed

## 3.4 Configuration Tips

### Introduction

Listed below in Table 3-1 are some tips that will help you enter the configuration data more quickly.

**Table 3-1 Configuration Tips**

Function	Tip
<b>Displaying groups</b>	Use the <b>SET UP</b> key to display the Set Up groups. The group titles are listed in this section in the order that they appear in the recorder.
<b>Displaying functions</b>	Use the <b>FUNC</b> key to display the individual parameters under each group. The prompts are listed in the order of their appearance in each group.
<b>Scrolling</b>	To get to a Set Up group prompt more quickly, hold the <b>SET UP</b> key in. To get to a function prompt more quickly, hold the <b>FUNC</b> key in. The display will scroll through the parameters.  <b>ATTENTION</b> The prompting scrolls at a rate of 2/3 seconds when the <b>SET UP</b> or <b>FUNC</b> key is held in. Also, [ <b>▲</b> ] [ <b>▼</b> ] keys will move group prompts forward or backward at a rate twice as fast.
<b>Changing values quickly</b>	When Changing the value of a parameter, you can adjust a more significant digit in the upper display by holding in one key [ <b>▲</b> ] or [ <b>▼</b> ] , and pressing the other [ <b>▲</b> ] or [ <b>▼</b> ] at the same time. <ul style="list-style-type: none"> <li>• The adjustment will move one digit to the left.</li> <li>• Press the key again and you will move one more digit to the left.</li> </ul>
<b>Restoring to the original value</b>	When you change the value or selection of a parameter while in Set Up mode and decide not to enter it, press <b>RUN/HOLD</b> once, the original value or selection will be recalled.
<b>Exiting Set Up mode</b>	To exit Set Up mode, press the <b>LOWR DISP</b> key. This returns the display to the same state it was in immediately preceding entry into the Set Up mode.
<b>Timing out from Set Up mode</b>	If you are in Set Up mode and do not press any keys for one minute, the recorder will time out and revert to the mode and display that was being used prior to entry into Set Up mode.
<b>Key error</b>	When a key is pressed and the prompt "KEY ERROR" appears in the lower display, it will be for one of the following reasons: <ul style="list-style-type: none"> <li>• parameter not available</li> <li>• not in Set Up mode, press <b>SET UP</b> key first</li> <li>• key malfunction, do keyboard test (operation)</li> <li>• individual key locked out</li> </ul>

## 3.5 Configuration Procedure

### Introduction

- Each of the Set Up groups and their functions are preconfigured at the factory.
- The factory settings are shown in the Set Up group tables that follow this procedure.
- If you want to change any of these selections or values, follow the procedure in Table 3-2. This procedure tells you the keys to press to get to any Set Up group and any associated Function parameter prompt.
- **If you need a detailed explanation of any prompt, refer to *Section 4 – Configuration Parameter Definitions*.**

### Procedure

Follow the procedure listed in Table 3-2 to access the Set Up groups and Function prompts.



#### TIP

The prompting scrolls at a rate of 2/3 seconds when the **SET UP** or **FUNC** key is held in. Also, [▲] [▼] keys will move group prompts forward or backward at a rate twice as fast.

**Table 3-2 Configuration Procedure**

Step	Operation	Press	Result
1	Select Set Up mode	<b>SET UP</b>	<i>Upper Display:</i> SET UP—Lets you know you are in the configuration mode and a Set Up group title is being displayed in the lower display. <i>Lower Display:</i> INPUT 1—This is the first Set Up group title.
2	Select any Set Up group	<b>SET UP</b>	<ul style="list-style-type: none"> <li>• Successive presses of the <b>SET UP</b> key will sequentially display the other Set Up group titles shown in the prompt hierarchy in Figure 3-1.</li> <li>• You can also use the [▲] [▼] keys to scan the Set Up groups in both directions.</li> <li>• Stop at the Set Up group title which describes the group of parameters you want to configure. Then proceed to the next step.</li> </ul>
3	Select a Function parameter	<b>FUNC</b>	<i>Upper Display:</i> Shows the current value or selection for the first function prompt of the particular Set Up group that you have selected (EXAMPLE: ENABLE/DISABLE). <i>Lower Display:</i> —Depends on what is selected in Set Up group. Shows the first function prompt within that Set Up group. Example: “INPUT 1”
4	Select other Function parameters	<b>FUNC</b>	<ul style="list-style-type: none"> <li>• Successive presses of the <b>FUNC</b> key will sequentially display the other function prompts of the Set Up group you have selected.</li> <li>• Stop at the function prompt that you want to change, then proceed to the next step.</li> </ul>

Step	Operation	Press	Result
5	Change the value or selection	▲ or ▼	<ul style="list-style-type: none"> <li>• These keys increment or decrement the value or selection that appears for the function prompt you have selected.</li> <li>• See <i>Subsection 3.4 Configuration Tips</i> for instructions to increase or decrease value quickly.</li> <li>• Change the value or selection to meet your needs.</li> <li>• If the display flashes, you are trying to make an unacceptable entry.</li> </ul>
6	Enter the value or selection	<b>FUNC</b>  or  <b>SET UP</b>	<ul style="list-style-type: none"> <li>• This key selects another function prompt.</li> <li>• This key selects another Set Up group.</li> </ul> <p>The value or selection you have made will be entered into memory after another key is pressed.</p>
7	Exit configuration	<b>LOWR DISP</b>	<p>This exits configuration mode and returns the recorder to the same state it was in immediately preceding entry into the Set Up mode. It stores any changes you have made.</p>

## 3.6 Input Set Up Group

### Introduction

This data deals with various parameters required to configure input 1, input 2, input 3, or input 4.

### Function prompts

Table 3-3 lists all the function prompts in the "INPUT 1" Set Up group. Repeat the process for each input you want to set up.

- Press the SET UP key until INPUT 2, INPUT 3, or INPUT 4 appears in the display.

**Table 3-3 Input Group Function Prompts**

Function Prompt Lower Display	Function Name	Selections or Range of Setting Upper Display	Factory Setting
<b>INPUT 1</b>	Input 1 Actuation	DISABL ENABLE	ENABLE
<b>DECIMAL</b>	Decimal Point Location	XXXX None XXX.X One XX.XX Two X.XXX Three	XXX.X
<b>UNITS</b>	Temperature Units	DEG F DEG C XXXXX (make selection at prompt "ENGUNITS")	DEG F
<b>ENGUNITS</b>	Engineering Units	0 to 9 A to Z + - \ (blank)	
<b>IN1 TYPE</b>	Input 1 Actuation Type	B TC            W TC H E TC H        W TC L E TC L        100 PT J TC H        200 HI* J TC L        200 LO* K TC H        500 PT K TC L        100 RH NNM TC       4-20 mA NIC TC        0-10 mV R TC           10-50m S TC           0-5 V T TC H        0-10 V T TC L        RADIAM  *DR45AR only	100 PT or 0-5 V with Control

Function Prompt Lower Display	Function Name	Selections or Range of Setting Upper Display	Factory Setting
<b>XMITTER</b>	Transmitter Characterization	B TC            T TC H E TC H        T TC L E TC L        W TC H J TC H        W TC L J TC L        100 PT K TC H        500 PT K TC L        100 RH NNM TC H     LINEAR* NIC TC        SQROOT* R TC S TC  *Set "IN1HI" and "IN1LO"	Linear
<b>IN1 HI</b>	Input 1 High Range Value (linear inputs only)	-999.0 to 9999. in engineering units	900
<b>IN1 LO</b>	Input 1 Low Range Value (linear inputs only)	-999.0 to 9999. in engineering units	-300
<b>CUTOFF 1</b>	Low Flow Cutoff Selection	0 to 100 % of input range	0
<b>INPTCOMP</b>	Input Compensation	-999.9 to 9999.	0
<b>FILTER 1</b>	Input 1 Filter	0 to 120 seconds	0
<b>BURNOUT</b>	Burnout Protection	NONE UP DOWN	UP
<b>EMISSIV</b>	Emissivity	.01 to 1.00	.01

***Repeat this procedure for INPUT 2, INPUT 3, and INPUT 4.***

## 3.7 Pen Set Up Group

### Introduction

The functions listed in this group deal with how to configure pen #1, pen #2, pen #3, or pen #4. The procedure for configuring each pen is the same. The prompts shown in Table 3-4 show PEN 1.

- Repeat the process for each pen you want to set up.
- Press the SET UP key until PEN 2, PEN 3, or PEN 4 appears in the display.

### Function prompts

Table 3-4 lists all the function prompts in the PEN Set Up groups.

**Table 3-4 Pen 1, 2, 3, 4 Group Function Prompts**

Function Prompt Lower Display	Function Name	Selections or Range of Setting Upper Display	Factory Setting
<b>PEN 1</b> (or <b>PEN 2</b> , <b>PEN 3</b> , <b>PEN 4</b> )	Pen Record	ENABLE DISABL	ENABLE
<b>PEN1IN</b> (or <b>PEN2IN</b> , <b>PEN3IN</b> , <b>PEN4IN</b> )	Pen Input	INPUT1    RH            SETPT2 INPUT2    OUTPT1        DGTL1 INPUT3    OUTPT2        DGTL2 INPUT4    SETPT1        PV1	INPUT 1
<b>CHART1HI</b> (or <b>CHART2HI</b> , <b>CHART3HI</b> , <b>CHART4HI</b> )	Chart High Range Value	-999.0 to 9999	302.0
<b>CHART1LO</b> (or <b>CHART2LO</b> , <b>CHART3LO</b> , <b>CHART4LO</b> )	Chart Low Range Value	-999.0 to 9999	292.0
<b>PEN1ON</b> (or <b>PEN2ON</b> , <b>PEN3ON</b> , <b>PEN4ON</b> )	Pen Chart Position for ON Event	0 to 100 %	91.0
<b>PEN1OFF</b> (or <b>PEN2OFF</b> , <b>PEN3OFF</b> , <b>PEN4OFF</b> )	Pen Chart Position for OFF Event	0 to 100 %	93.0
<b>MAJORDIV</b>	Major Chart Divisions	2 to 10	10
<b>MINORDIV</b>	Minor Chart Division	2 to 10	10
<b>RNG1TAG</b>	Range 1 Tag Name	0 to 9 A to Z + - / (blank)	RNG 1

*Repeat this procedure for PEN 2, PEN 3, and PEN 4.*



## 3.8 Chart Set Up Group

### Introduction

The functions listed in this group deal with the parameters that must be set to assure proper chart function.



#### CAUTION

Before making any configuration changes to the "Chart" Set Up group, place the recorder in "Chart Hold". Press the **CHART** key to stop the chart rotation. Press again after configuration entry is made.

### Function prompts

Table 3-5 lists all the function prompts in the "Chart" Set Up group.

**Table 3-5 Chart Group Function Prompts**

Function Prompt Lower Display	Function Name	Selections or Range of Setting Upper Display	Factory Setting
<b>CHRTSPD</b>	Chart Speed Selection	8HR 12HR 24HR 7DAYS XHR (See prompt "HOUR/REV")	XHR
<b>HOUR/REV</b>	Hours per Revolution (appears only if "XHR" is selected above)	6 to 744 (12 hrs for abrasion resistant pen) NOTE: Below 8 hrs chart speed (24 hrs chart speed with abrasion resistant pen), printing may be degraded.	12
<b>TIME DIV</b>	Time Division	8 to 24 time periods	24
<b>MINORDIV</b>	Minor Time Division	Four Eight	Four
<b>CONTINUE</b>	Continue Chart Rotation	YES NO	NO
<b>CHARTNAM</b>	Chart Name	0 to 9 A to Z + - / (blank)	TRULIN
<b>HEADER</b>	Header for Chart	YES NO	NO

<b>Function Prompt Lower Display</b>	<b>Function Name</b>	<b>Selections or Range of Setting Upper Display</b>	<b>Factory Setting</b>
<b>REM CHRT</b>	Remote Chart Activation	NONE EXT SW1 EXT SW2 ALARM 1 ALARM 2 TIME (See "WAKE MIN", "WAKE HOUR", "WAKE DAY", "WAKE MON" in Time Set Up group.) ALARM 3 ALARM 4 ALARM 5 ALARM 6	NONE

## 3.9 Time Set Up Group

### Introduction

The functions listed in this group deal with the parameters that let you configure the real time that will appear on the chart.

### Function prompts

Table 3-6 lists all the function prompts in the “Time” Set Up group.

**Table 3-6 Time Group Function Prompts**

Function Prompt Lower Display	Function Name	Selections or Range of Setting Upper Display	Factory Setting
<b>MINUTES</b>	Real Time in Minutes Chart Speed Selection	0 to 59	Set to local time
<b>HOURS</b>	Real Time in Hours	0 to 23	
<b>DAY</b>	Real Time in Days	1 to 31	
<b>MONTH</b>	Real Time in Months	1 to 12	
<b>YEAR</b>	Real Time in Years	0 to 99	
<b>DAY</b>	Day of the Week Chart Name	MONDAY TUEDAY WEDDAY THRDAY FRIDAY SATDAY SUNDAY	
<b>WAKE MIN</b>	Wake Minutes	0 to 59	0
<b>WAKE HR</b>	Wake Hour	0 to 23	0
<b>WAKE DAY</b>	Wake Day	0 to 31	0
<b>WAKE MON</b>	Wake Month	1 to 12	1

## 3.10 Totalizer Set Up Group

### Introduction

The functions listed in this group deal with the calculation and display of the total flow volume as measured by input 1 (total 1) or input 2 (total 2). The displayed value is 8 digits with a configurable scale factor.

### Function prompts

Table 3-7 lists all the function prompts in the “TOTAL 1” Set Up group. Repeat the process for each input you want to set up.

- Press the **SET UP** key until TOTAL 2 appears in the display.

**Table 3-7 Totalizer Group Function Prompts**

Function Prompt Lower Display	Function Name	Selections or Range of Setting Upper Display	Factory Setting
<b>Actual Current Totalized Value</b>	View Current Totalized Value	Current Scale Factor Example: E1 GPM	E0 GAL
<b>RSET TOT</b>	Reset Totalizer to Zero (RSETABLE must be set to “LOCAL”)	NO YES	NO
<b>TOTAL 1 TOTAL 2</b>	Totalizer 1 Totalizer 2	DISABL, INPUT1, PV1, INPUT2, INPUT 3, INPUT 4, E TIME	DISABL
<b>TOTAL EU</b>	Total Engineering Units	0 to 9 A to Z + - / (blank)	GAL
<b>RATE</b>	Rate of Integration	SECOND MINUTE HOUR DAY M/DAY (Millions of Units per Day)	SECOND
<b>SCALER</b>	Totalizer Scale Factor	1 10 100 1000 10000 100000 1E6 (1,000,000)	1
<b>RSETABLE</b>	Totalizer Reset	NO LOCAL EXTSW1* EXTSW2* TIME  *Total will be set to “0” on closure of the assigned external switch.	NO

<b>Function Prompt Lower Display</b>	<b>Function Name</b>	<b>Selections or Range of Setting Upper Display</b>	<b>Factory Setting</b>
<b>INHIBIT</b>	Totalizer Inhibit	NONE S1 OPEN S1 CLOSE S2 OPEN S2 CLOSE	NONE

*Repeat this procedure for INPUT 2.*

## 3.11 Input Algorithm Set Up Group

### Introduction

Input Algorithm set up group lets you calculate a process variable (PV1) using Inputs 1, 2, and 3. Input 1 is represented by 'A', Input 2 by 'B', Input 3 by 'C'.

### Function prompts

Table 3-8 lists all the function prompts in the Input Algorithm Set Up group.

**Table 3-8 Input Algorithm Group Function Prompts**

Function Prompt Lower Display	Function Name	Selections or Range of Setting Upper Display	Factory Setting
<b>INP ALG</b>	Input Algorithm	NONE A+B+C (Summer) $\sqrt{A*B/C}$ (Square Root Multiplier/Divider) $\sqrt{A*B*C}$ (Square Root Multiplier) A*B/C (Multiplier/Divider) A*B*C (Multiplier) (A-B)*C (Difference Multiply) HI SELECT LO SELECT	NONE
<b>COEFF</b>	Coefficient K	0.000 to 1000.0	1.0
<b>PV HIGH</b>	Calculated PV High Limit	-999 to 9999	0.0
<b>PV LOW</b>	Calculated PV Low Limit	-999 to 9999	0.0
<b>RATIO A</b>	Ratio for Input 1	-20.00 to 20.00	1.0
<b>BIAS A</b>	Bias for Input 1	-999 to 9999	0.0
<b>RATIO B</b>	Ratio for Input 2	-20.00 to 20.00	1.0
<b>BIAS B</b>	Bias for Input 2	-999 to 9999	0.0
<b>RATIO C</b>	Ratio for Input 3	-20.00 to 20.00	1.0
<b>BIAS C</b>	Bias for Input 3	-999 to 9999	0.0
<b>POLYNOM</b>	Polynomial characterizer	NONE, INPUT 1, INPUT 2, INPUT 3, INPUT 4	NONE
<b>C0 VALUE</b>	Polynomial coefficient C0	-99.99 to 99.99	0
<b>C1 VALUE</b>	Polynomial coefficient C1	-9.999 to 9.999	0
<b>C2x10-1</b>	Polynomial coefficient C2	-9.999 to 9.999	0
<b>C3x10-3</b>	Polynomial coefficient C3	-9.999 to 9.999	0
<b>C4x10-5</b>	Polynomial coefficient C4	-9.999 to 9.999	0
<b>C5x10-7</b>	Polynomial coefficient C5	-9.999 to 9.999	0

## 3.12 Control Set Up Group

### Introduction

This data deals with various parameters required to effectively control your process.

### Function prompts

Table 3-9 lists all the function prompts in the “CONTROL 1” or “CONTROL 2” Set Up group. You can enable the Control groups in the Option group.

**Table 3-9 Control 1 or Control 2 Group Function Prompts**

Function Prompt Lower Display	Function Name	Selections or Range of Setting Upper Display	Factory Setting
<b>CONTROL1</b>	Control Loop 1	DISABL ENABLE	ENABLE
<b>PID SETS</b>	Tuning Parameter Sets	1 ONLY 2KEYBD 2PV SW 2SP SW	1 ONLY
<b>SW VALUE</b>	Automatic Switchover Value	–999.0 to 9999	0.00
<b>SP SOURC</b>	Setpoint Source	1 LOCAL REMOTE 2 LOCAL OUT 2 (available for Control 1 only)  NOTE: If you select “REMOTE,” Input #3 is automatically assigned as your RSP source for control #1; Input #4 is assigned for control #2. However, if the unit has only 2 inputs, then RSP will be on Input 2.	1 LOCAL
<b>RATIO</b>	Ratio for Remote Setpoint	–20.00 to 20.00	1.0
<b>BIAS</b>	Bias for Remote Setpoint	–999.0 to 9999 in engineering units	0
<b>SP TRACK</b>	Setpoint Tracking Totalizer Scale Factor	NONE RSP	NONE
<b>POWER UP</b>	Power Up Controller Mode Recall	MANUAL A LSP A RSP AM SP AM LSP	MANUAL
<b>PWR OUT</b>	Power Up Output	LAST FAIL SF  NOTE: This prompt will appear only if “3PSTEP” is selected at function prompt “CONT ALG”.	LAST
<b>SP HILIM</b>	High Setpoint Limit	–999.0 to 9999.	500
<b>SP LOLIM</b>	Low Setpoint Limit	–999.0 to 9999.	0

Function Prompt Lower Display	Function Name	Selections or Range of Setting Upper Display	Factory Setting
<b>ACTION</b>	Control Output Direction	DIRECT REVRSE	REVERSE
<b>OUTHILIM</b>	High Output Limit	-5.0 to 105.0 % of output	100.0
<b>OUTLOLIM</b>	Low Output Limit	-5.0 to 105.0 % of output	0
<b>DROPOFF</b>	Controller Dropoff Value	-5.0 to 105.0 % of output	0.0
<b>DEADBAND</b>	Output Relay Deadband	<ul style="list-style-type: none"> <li>• Time Proportional Duplex: -5.0 to 25.0 %</li> <li>• On-Off Duplex: 0.0 to 25.0 %</li> <li>• Position Proportional 0.5 to 5.0 %</li> </ul>	2.0
<b>OUT HYST</b>	Output Relay Hysteresis	0.0 to 5.0 % of PV Span	0.5
<b>FAILSAFE</b>	Failsafe Output Value	0 to 100 %	50
		<b>For 3 Position Step Control:</b>  100PCT    Set motor position to 100 % output position  0PCT      Set motor to 0 % output position	0.0
<b>REM SW</b> or <b>REM SW2</b>	Remote Switching (Digital Input)	NONE            TO 2SP            TUNE TO MAN            TO DIR            TIMER TO LSP            RN/HLD	NONE
<b>MAN KEY</b>	Manual Mode Key Selection	ENABLE DISABL	ENABLE
<b>PB orGAIN</b>	Proportional Band or Gain Units	PB PCT GAIN	GAIN
<b>MIN orRPM</b>	Reset Units	R P M (repeats per minute) M I N (minutes per repeat)	MIN
<b>CONT1 ALG</b> or <b>CONT2 ALG</b>	Control Algorithm	ON-OFF            PD+MR PID-A              3PSTEP* PID-B  *not applicable for model DR45AR	PID-A
<b>OUT1 ALG</b> or <b>OUT2 ALG</b> (appears if not 3PSTEP above)	Output Algorithm	TIME*              TIME D* CURRNT            CUR TI* POSITN*            TI CUR*  *not applicable for Model DR45AR	CURRENT
<b>4-20RNG</b>	Current/Time Duplex Range (CUR D)	100PCT (FULL) 50 PCT (SPLIT)	50PCT



## 3.13 Tuning Parameters Set Up Group

### Introduction

These Tuning Set Up groups contain the Function parameters that will allow your recorder to respond correctly to changes in process variable or setpoint. You can start with predetermined values but you will have to watch your process to determine how to modify them.

### Function prompts

Table 3-10 lists all the function prompts in the Tuning 1 or Tuning 2 Set Up groups. How the “Algorithm” and “Control” Set Up groups are configured determines which prompts will appear.

**Table 3-10 Tuning 1 or Tuning 2 Group Function Prompts**

Function Prompt Lower Display	Function Name	Selections or Range of Setting Upper Display	Factory Setting
<b>FUZZY</b>	Fuzzy Overshoot Suppression	DISABL ENABLE	DISABL
<b>ACCUTUNE</b>	Accutune II for Control Loop	DISABL ENABLE	DISABL
<b>AT ERR</b>	Accutune Error Codes	No message under normal conditions  Read Only message displayed if tuning has been manually aborted	—
<b>PROP BD</b> or <b>GAIN</b>	Proportional Band or Gain	0.1 to 1000 %  0.1 to 1000	1.0
<b>RATE MIN</b>	Rate in minutes	0.00 to 10.00 minutes	0.00
<b>RSET MIN</b> or <b>RSET RPM</b>	Reset in minutes/repeat or Reset in repeats/minute	0.02 to 50.00  0.02 to 50.00	1.0  1.0
<b>MAN RSET</b>	Manual Reset	–100 to 100 % output	0.0
<b>PROP BD2</b> or <b>GAIN 2</b>	Proportional Band 2 or Gain 2	0.1 to 1000 %  0.1 to 1000	5.0
<b>RATE2MIN</b>	Rate 2 in minutes	0.08 to 10.00 minutes	0.00
<b>RSET2MIN</b>  <b>RSET2RPM</b>	Reset 2 in minutes/repeat  Reset 2 in repeats/minute	0.02 to 50.00  0.02 to 50.00	0.2  0.2
<b>CYC SEC</b>	Cycle Time (Heat) Electromechanical Relays	1 to 120 seconds	20.0
<b>CYC2 SEC</b>	Cycle Time 2 (Cool) Electromechanical Relays	1 to 120 seconds	20.0

### 3.14 SP Ramp Set Up Groups

The Setpoint Ramp 1 or 2 Set Up groups let you configure 2 setpoint ramps. Each group (SP RAMP1 and SP RAMP 2) can be configured one of three ways: ramp, rate, or setpoint program.

#### Setpoint Ramp

Setpoint will ramp between the current local setpoint and a final setpoint over a time interval (SP RAMP).

#### Setpoint Rate

The Setpoint Ramp Set Up group also contains the function parameters that let you configure a specific ramp rate up and ramp rate down (SP RATE). These rates are used when the local setpoint is manually changed.

#### Setpoint Program

Also included under this group are prompts for configuring a Setpoint program (SP PROG). The prompts and instructions for Setpoint programming are presented in the *Section 6 - Setpoint Ramp/Soak Programming and Operation*.

#### Function prompts

Table 3-11 lists all the function prompts in the SP RAMP 1 or SP RAMP 2 Set Up group. Configure each ramp separately. When you enable the ramp type (SP RAMP, SP RATE, SP PROG) the other two types are hidden from the display.

**Table 3-11 SP Ramp 1 or 2 Group Function Prompts**

Function Prompt Lower Display	Function Name	Selections or Range of Setting Upper Display	Factory Setting
<b>SP RAMP*</b>	Single Setpoint Ramp Selection	DISABL ENABLE	DISABL
<b>TIME MIN</b>	Single Setpoint Ramp Time	0 to 255 minutes	0
<b>FINAL SP</b>	Single Setpoint Ramp Final Setpoint	Enter a value within the setpoint limits	100.0
<b>SP RATE*</b>	Setpoint Rate	DISABL ENABLE	DISABL
<b>EU/HR UP</b>	Rate up value (SP Rate enabled)	0 to 9999 in units per hour	0
<b>EU/HR DN</b>	Rate down value (SP Rate enabled)	0 to 9999 in units per hour	0
<b>SP PROG*</b>	Setpoint Programming (Refer to Section 6)	DISABL ENABLE	DISABL

\*Only one of these can be enabled at a time.

## 3.15 Timer Set Up Group

### Introduction

The Timer gives a countdown or elapsed time, after which Relay 1 energizes. If Timer is enabled, it has exclusive control over Relay 1; Alarm 1 will not control the relay.

### Function prompts

Table 3-12 lists all the function prompts in the TIMER Set Up group.

**Table 3-12 Timer Group Function Prompts**

Function Prompt Lower Display	Function Name	Selections or Range of Setting Upper Display	Factory Setting
<b>TIMER</b>	Timer Enable/Disable	ENABLE DISABL	DISABL
<b>PERIOD</b>	Timeout Period	0:00 to 99:59	0
<b>START</b>	Start Initiation	RHKEY ALARM2 TIME	RHKEY
<b>LDISPLAY</b>	Timer Display	TREM ET	TREM
<b>RESET</b>	Timer Reset Control	RHKEY ALARM1 REPEAT	RHKEY
<b>ON-TIME</b>	Timer Repeat Mode On-Time	1 SEC 2 SEC 3 SEC 4 SEC 5 SEC	
<b>INCRMENT</b>	Timer Count Increment	MINUTE SECOND	MINUTE

## 3.16 Alarms Set Up Group

### Introduction

This data deals with the Alarms function that is available with your recorder.

- There are six alarms available. Each alarm has two setpoints.
- You can configure each of these two setpoints to alarm on various recorder parameters. There are two alarm output selections, high or low.
- You can also configure the two setpoints to alarm on the same event and to alarm both high and low, if desired. An adjustable hysteresis of 0.0 % to 100.0 % is configurable for each alarm.

### Priority of functions that operate relays

During alarm conditions an alarm will deenergize its associated relay unless a higher priority function has been configured for that relay. See Table 3-13. If you want the alarm to control the relay, do not configure a higher priority function.

**Table 3-13 Priority of functions that operate relays**

Relay	Relay is controlled by (in order of priority)
1	1. Timer function 2. Alarm 1
2	Alarm 2 only
3	1. Controller 1 output algorithms Relay Simplex, Position Proportional, Relay Duplex, Current/Relay Duplex 2. Alarm 3
4	1. Controller 1 output algorithms Position Proportional, Relay Duplex, Current/Relay Duplex 2. Alarm 4
5	1. Controller 2 output algorithms Relay Simplex, Position Proportional, Relay Duplex, Current/Relay Duplex 2. Alarm 5
6	1. Controller 2 output algorithms Position Proportional, Relay Duplex, Current/Relay Duplex 2. Alarm 6

**Function prompts**

Table 3-14 lists all the function prompts in the Alarms Set Up group.

**Table 3-14 Alarms Group Function Prompts**

Function Prompt Lower Display	Function Name	Selections or Range of Setting Upper Display	Factory Setting
<b>AxS1 VAL</b>	Alarm 1, Setpoint 1 Value	Value in engineering units	90
<b>AxS2 VAL</b>	Alarm 1, Setpoint 2 Value	Value in engineering units	95
<b>AxS1TYPE</b>	Alarm 1, Setpoint 1 Type	NONE IN 1 (Input 1) IN 2 (Input 2) IN 3 (Input 3) IN 4 (Input 4) RH (Relative Humidity) PV (Process Variable Loop 1) DEV (Loop 1 Deviation) OUT (Loop 1 Output) DEV2 (Loop 2 Deviation) OUT2 (Loop 2 Output) EVENT (SP Programming-Segment Event) TOTAL 1 (Totalizer to Alarm On) TOTAL 2 (Totalizer to Alarm On) TOTAL 3 (Model DR45AW only) TOTAL 4 (Model DR45AW only)	IN 1
<b>AxS2TYPE</b>	Alarm 1, Setpoint 2 Type	Same as A1S1TYPE	IN 1
<b>AxS1 H L</b>	Alarm 1, Setpoint 1 State	LO (Low Alarm) HI (High Alarm)	LO
<b>AxS1SCAL</b>	Alarm 1, Setpoint 1 Scaling Multiplier for Totalizer Selection	1            10000 10           100000 100          1E6 1000	1
<b>AxS2 H L</b>	Alarm 1, Setpoint 2 State	LO HI	HI
<b>AxS2SCAL</b>	Alarm 1, Setpoint 2 Scaling Multiplier for Totalizer Selection	1 10 100 1000 10000 100000 1E6	1
<b>ALx HYST</b>	Alarm Hysteresis	0.0 to 100.0 % of Input Span as appropriate	0.1

*Repeat this procedure for ALARM 2, ALARM 3, ALARM 4, ALARM 5, ALARM 6.*

## 3.17 Auxiliary Output Set Up Group

### Introduction

The auxiliary output will supply a 4-20mA output scaled to one of four operating parameters: Input, Output, Setpoint, or Deviation. This current is supplied from a separate option card. AUX OUT 2 and AUX OUT 3 use CONTROL CURRENT OUT 1 and CONTROL CURRENT OUT 2 if CONTROL OUT ALG is not set to CURRENT.

### Function prompts

Table 3-15 lists all the function prompts in the Auxiliary Output Set Up group.

**Table 3-15 Auxiliary Output Group Function Prompts**

Function Prompt Lower Display	Function Name	Selections or Range of Setting Upper Display	Factory Setting
<b>AUX OUT 1</b>	Auxiliary Output Representation	DISABL      PV 2 IN 1        DEV 2 IN 2        OUT 2 PV 1        SP 2 DEV 1       IN 3 OUT 1       IN 4 SP 1	DISABL
<b>4 mA VAL</b>	Low Scaling Factor	Low scale value to represent 4 mA	0.0
<b>20mA VAL</b>	High Scaling Factor	High scale value to represent 20 mA	100.0

*Repeat this procedure for AUX OUT 2 and AUX OUT 3.*

## 3.18 Modbus Communications Set Up Group

### Introduction

This data deals with the Communications option that is available with your recorder. This option allows the recorder to be connected to a host computer via the Modbus protocol.

If your recorder does not have this option the prompts will not appear.



#### ATTENTION

Refer to Documents 51-52-25-66 and 51-52-25-69 for a complete description of the RS485 Modbus Communications Option.

---

### Function prompts

Table 3-16 lists all the function prompts in the Modbus Communications Set Up group.

**Table 3-16 Modbus Communications Group Function Prompts**

Function Prompt Lower Display	Function Name	Selections or Range of Setting Upper Display	Factory Setting
<b>ComSTATE</b>	Modbus Communications	DISABL MODBUS	DISABL
<b>Com ADDR</b>	Communications Station Address	1 to 99	1
<b>BAUD</b>	Communications Baud Rate	300 600 1200 2400 4800 9600 19200 38400	9600
<b>XMT DLAY</b>	Transmit Delay (in milliseconds)	NONE 10MSEC 20MSEC 30MSEC 40MSEC 50MSEC	NONE
<b>DBL BYTE</b>	Double Byte Order	FP B FP BB FP L FP LB	FP B

## 3.19 Options Set Up Group

### Introduction

This data deals with various options that are available with your recorder. If your recorder does not have any of these options the prompts will not appear.

### Function prompts

Table 3-17 lists all the function prompts in the Option Set Up group.

**Table 3-17 Options Group Function Prompts**

Function Prompt Lower Display	Function Name	Selections or Range of Setting Upper Display	Factory Setting
<b>REJ FREQ</b>	Rejection Frequency	50HZ 60HZ	60HZ
<b>HF REJ</b>	High Frequency Rejection	ENABLE DISABL	ENABLE
<b>RELHUMID</b>	Relative Humidity	NO YES	NO
<b>ATMPRES</b>	Atmospheric Pressure Compensation	590 to 800 mmHg	—
<b>DEVIATION</b>	Deviation Recording Action	NONE SETPNT CHAN1	NONE
<b>DEVSETPT</b>	Deviation Setpoint Value	–999.0 to 9999	0
<b>SCROLL</b>	Lower Display Scroll	NONE 1 SEC 2 SEC 3 SEC	NONE
<b>GRANDTOT</b>	Grand Totalizer	ENABLE DISABL	DISABL



## 3.20 Event Message Configuration

### Introduction

This Set Up group allows you to specify an event message to be printed on a designated area of the chart when triggered by a specific selectable actuation.

### Function prompts

Table 3-18 lists all the function prompts in the “Event Message” Set Up group.

**Table 3-18 Event Message Group Function Prompts**

Function Prompt Lower Display	Function Name	Selections or Range of Setting Upper Display	Factory Setting
<b>EVENT1</b>	Event 1 Trigger	NONE EXTSW1 EXTSW2 ALARM1 ALARM2 ALARM3 ALARM4 ALARM5 ALARM6	NONE
<b>MESSAGE1</b>	Message for Event 1 (up to six characters)	0 to 9 A to Z + - / (blank)*	EVENT1
<b>POSITON1</b>	Chart Position for Message 1 Printing	0 to 100 %	87.3
<b>EVENT 2</b>	Event 2 Trigger	NONE EXTSW1 EXTSW2 ALARM1 ALARM2 ALARM3 ALARM4 ALARM5 ALARM6	NONE
<b>MESSAGE2</b>	Message for Event 2 (up to six characters)	0 to 9 A to Z + - / (blank)*	EVENT2
<b>POSITON2</b>	Chart Position for Message 2 Printing	0 to 100 %	85.5

Function Prompt Lower Display	Function Name	Selections or Range of Setting Upper Display	Factory Setting
<b>EVENT 3</b>	Event 3 Trigger	NONE EXTSW1 EXTSW2 ALARM1 ALARM2 ALARM3 ALARM4 ALARM5 ALARM6	NONE
<b>MESSAGE3</b>	Message for Event 3 (up to six characters)	0 to 9 A to Z + - / (blank)*	EVENT3
<b>POSITON3</b>	Chart Position for Message 3 Printing	0 to 100 %	83.6
<b>EVENT 4</b>	Event 4 Trigger	NONE EXTSW1 EXTSW2 ALARM1 ALARM2 ALARM3 ALARM4 ALARM5 ALARM6	NONE
<b>MESSAGE4</b>	Message for Event 4 (up to six characters)	0 to 9 A to Z + - / (blank)*	EVENT4
<b>POSITON4</b>	Chart Position for Message 4 Printing	0 to 100 %	80.0
<b>EVENT 5</b>	Event 5 Trigger	NONE EXTSW1 EXTSW2 ALARM1 ALARM2 ALARM3 ALARM4 ALARM5 ALARM6	NONE
<b>MESSAGE5</b>	Message for Event 5 (up to six characters)	0 to 9 A to Z + - / (blank)*	EVENT5

Function Prompt Lower Display	Function Name	Selections or Range of Setting Upper Display	Factory Setting
<b>POSITON5</b>	Chart Position for Message 5 Printing	0 to 100 %	78.2
<b>EVENT 6</b>	Event 6 Trigger	NONE EXTSW1 EXTSW2 ALARM1 ALARM2 ALARM3 ALARM4 ALARM5 ALARM6	NONE
<b>MESSAGE6</b>	Message for Event 6 (up to six characters)	0 to 9 A to Z + - / (blank)*	EVENT6
<b>POSITON6</b>	Chart Position for Message 6 Printing	0 to 100 %	76.9

\*For alphanumeric entries, the display will cycle, from left to right, with highlighting (increased brightness) of each digit. The value of each digit can be changed only when it is highlighted.

## 3.21 Lockout Set Up Group

### Introduction

These are the parameters that you will select to lockout any unauthorized changes to the recorder's configuration and calibration prompts. You must know the password in order to change the Lockout configuration.

### Function prompt

Table 3-19 lists all the function prompts in the Lockout Set Up group.

**Table 3-19 Lockout Group Function Prompts**

Function Prompt Lower Display	Function Name	Selections or Range of Setting Upper Display	Factory Setting
<b>PASSWORD</b>	Lockout Password	Select up to 4 alphanumeric characters (++++ is factory default password)  For more information on password security, refer to Appendix B.	XXXX
<b>LOCKOUT</b>	Lockout	NONE CALIB +CONF MAX	CALIB
<b>CHANGE</b>	Change Password	0 to 9 A to Z	XXXX



#### ATTENTION

Configuration can also be locked using S1 switch on the main printed circuit board. Refer to *Subsection 2.9 –Lockout Switch Configuration*.

---

This feature also includes the special screw and plate that provide for the lead seal capability for sealing the chart plate.

## 3.22 Adjust Printing

### Introduction

This data deals with the “Adjust Printing” feature of the Truline recorder. This feature is important to the operation of the hot stylus pen.

Configuration choices are provided for PEN TYPE and the selection must match the stylus design.

- PEN TYPE = NORMAL is for the high-speed stylus design.
- PEN TYPE = JEWEL is used *only* for abrasion resistant stylus design.



#### CAUTION

If the “JEWEL” selection is accidentally used with the high-speed design, the life of that stylus will be shortened.

You can also make slight adjustments to the print contrast.

### Function prompt

Table 3-20 lists all the function prompts in the Adjust Set Up group.

**Table 3-20 Adjust Group Function Prompts**

Function Prompt Lower Display	Function Name	Selections or Range of Setting Upper Display	Factory Setting
TRACE LN	Trace Line Contrast	DARK MEDIUM LIGHT	MEDIUM
GRID LN	Grid Line Contrast	DARK MEDIUM LIGHT	MEDIUM
PEN TYPE	Stylus Selection	NORMAL – Select if high speed stylus (black tip) is installed.  JEWEL – Select if abrasion resistant stylus (beige tip) is installed.	NORMAL

### 3.23 Configuration Record Sheet

#### Keep a record

Enter the value or selection for each prompt on this sheet so you will have a record of how your recorder was configured.

Group Prompt	Function prompt	Value or Selection	Factory Setting	Group Prompt	Function prompt	Value or Selection	Factory Setting	
<b>INPUT 1</b>	DECIMAL	_____	XXX.X	<b>PEN 1</b>	PEN1IN	_____	INPUT1	
	UNITS	_____	DEGF		CHART1HI	_____	302.0	
	ENGUNITS	_____	—		CHART1LO	_____	292.0	
	IN1 TYPE	_____	100PT		PEN1ON	_____	91.0	
	XMITTER	_____	LINEAR		PEN1OFF	_____	93.0	
	IN1 HI	_____	900		MAJORDIV	_____	10	
	IN1 LO	_____	-300		MINORDIV	_____	10	
	CUTOFF 1	_____	0		RNG1TAG	_____	RNG1	
	INPTCOMP	_____	0		<b>PEN 2</b>	PEN2IN	_____	INPUT2
	FILTER 1	_____	0			CHART2HI	_____	302.0
	BURNOUT	_____	UP			CHART2LO	_____	292.0
	EMISSIV	_____	.01			PEN2ON	_____	91.0
	<b>INPUT 2</b>	DECIMAL	_____			XXX.X	PEN2OFF	_____
UNITS		_____	DEGF	MAJORDIV	_____	10		
ENGUNITS		_____	—	MINORDIV	_____	10		
IN2 TYPE		_____	100PT	RNG2TAG	_____	RNG2		
XMITTER		_____	LINEAR	<b>PEN 3</b>	PEN3IN	_____	INPUT3	
IN2 HI		_____	900		CHART3HI	_____	302.0	
IN2 LO		_____	-300		CHART3LO	_____	292.0	
CUTOFF 2		_____	0		PEN3ON	_____	91.0	
INPTCOMP		_____	0		PEN3OFF	_____	93.0	
FILTER 2		_____	0	MAJORDIV	_____	10		
BURNOUT		_____	UP	MINORDIV	_____	10		
EMISSIV		_____	.01	RNG3TAG	_____	RNG3		
<b>INPUT 3</b>		DECIMAL	_____	XXX.X	<b>PEN 4</b>	PEN4IN	_____	INPUT4
	UNITS	_____	DEGF	CHART4HI		_____	302.0	
	ENGUNITS	_____	—	CHART4LO		_____	292.0	
	IN3 TYPE	_____	100PT	PEN4ON		_____	91.0	
	XMITTER	_____	LINEAR	PEN4OFF		_____	93.0	
	IN3 HI	_____	900	MAJORDIV	_____	10		
	IN3 LO	_____	-300	MINORDIV	_____	10		
	CUTOFF 3	_____	0	RNG4TAG	_____	RNG4		
	INPTCOMP	_____	0	<b>CHART</b>	CHRTSPD	_____	XHR	
	FILTER 3	_____	0		HOUR/REV	_____	12	
	BURNOUT	_____	UP		TIME DIV	_____	24	
	EMISSIV	_____	.01		MINORDIV	_____	Four	
	<b>INPUT 4</b>	DECIMAL	_____		XXX.X	CONTINUE	_____	NO
UNITS		_____	DEGF	CHARTNAM	_____	TRULIN		
ENGUNITS		_____	—	HEADER	_____	NO		
IN4 TYPE		_____	100PT	REM CHRT	_____	NONE		
XMITTER		_____	LINEAR	<b>TIME</b>	MINUTES	_____	Set	
IN4 HI		_____	900		HOURS	_____	to	
IN4 LO		_____	-300		DAY	_____	local	
CUTOFF 4		_____	0		MONTH	_____	time	
INPTCOMP		_____	0		YEAR	_____		
FILTER 4		_____	0		DAY	_____		
BURNOUT		_____	DEGF		WAKE MIN	_____	0	
EMISSIV		_____	.01		WAKE HR	_____	0	
					WAKE DAY	_____	0	
			WAKE MON	_____	0			

Group Prompt	Function prompt	Value or Selection	Factory Setting	Group Prompt	Function prompt	Value or Selection	Factory Setting	
<b>TOTAL 1</b>	(Value)	_____	E0 GAL	<b>CONTROL 2</b>	CONTROL2	_____	ENABLE	
	RSET TOT	_____	NO		PID SETS	_____	1ONLY	
	TOTAL 1	_____	DISABL		SW VALUE	_____	0.0	
	TOTAL EU	_____	GAL		SP SOURC	_____	1LOCAL	
	RATE	_____	SECOND		RATIO	_____	1.0	
	SCALER	_____	1		BIAS	_____	0	
	RSETABLE	_____	NO		SP TRACK	_____	NONE	
<b>TOTAL 2</b>	(Value)	_____	E0 GAL		POWER UP	_____	MANUAL	
	RSET TOT	_____	NO		PWR OUT	_____	LAST	
	TOTAL 2	_____	DISABL		SP HILIM	_____	500	
	TOTAL EU	_____	GAL		SP LOLIM	_____	0	
	RATE	_____	SECOND		ACTION	_____	REVRSE	
	SCALER	_____	1		OUTHILIM	_____	100.0	
	RSETABLE	_____	NO		OUTLOLIM	_____	0	
<b>INP ALG</b>	INHIBIT	_____	NONE		DROPOFF	_____	0.0	
	INP ALG	_____	NONE		DEADBAND	_____	2.0	
	COEFF	_____	1.0		OUT HYST	_____	0.5	
	PV HIGH	_____	0.0		FAILSAFE	_____	50	
	PV LOW	_____	0.0		REM SW2	_____	NONE	
	RATIO A	_____	1.0		MAN KEY	_____	ENABLE	
	BIAS A	_____	0.0		PBorGAIN	_____	GAIN	
	RATIO B	_____	1.0		MINorRPM	_____	MIN	
	BIAS B	_____	0.0		CONT2ALG	_____	PIDA	
	RATIO C	_____	1.0		OUT2ALG	_____	CURRENT	
	BIAS C	_____	0.0		4-20 RNG	_____	50PCT	
	POLYNOM	_____	NONE		<b>TUNING 1</b>	FUZZY	_____	DISABL
	C0 VALUE	_____	0			ACCUTUNE	_____	DISABL
	C1 VALUE	_____	0			AT ERR	_____	Read only
	C2x10-1	_____	0	PROP BD		_____	1.0	
C3x10-3	_____	0	or	_____				
C4x10-5	_____	0	GAIN	_____		1.0		
C5x10-7	_____	0	RATE MIN	_____		0.00		
<b>CONTROL 1</b>	CONTROL1	_____	ENABLE	RSET MIN		_____	1.0	
	PID SETS	_____	1ONLY	or		_____		
	SW VALUE	_____	0.0	RSET RPM		_____	1.0	
	SP SOURC	_____	1LOCAL	MAN RSET		_____	0.0	
	RATIO	_____	1.0	CYCSEC		_____	20.0	
	BIAS	_____	0	PROP BD2	_____	1.0		
	SP TRACK	_____	NONE	or	_____			
	POWER UP	_____	MANUAL	GAIN 2	_____	1.0		
	PWR OUT	_____	LAST	RATE2MIN	_____	0.00		
	SPHILIM	_____	500	RSET2MIN	_____	1.0		
	SPLOLIM	_____	0	or	_____			
	ACTION	_____	REVRSE	RSET2RPM	_____	1.0		
	OUT HILIM	_____	100.0	CYC2SEC	_____	20.0		
	OUT LOLIM	_____	0					
DROPOFF	_____	0.0						
DEADBAND	_____	2.0						
OUT HYST	_____	0.5						
FAILSAFE	_____	50						
REM SW	_____	NONE						
MAN KEY	_____	ENABLE						
PBorGAIN	_____	GAIN						
MINorRPM	_____	MIN						
CONT1ALG	_____	PIDA						
OUT1ALG	_____	CURRENT						
4-20 RNG	_____	50PCT						

Group Prompt	Function prompt	Value or Selection	Factory Setting	Group Prompt	Function prompt	Value or Selection	Factory Setting	
<b>TUNING 2</b>	FUZZY	_____	DISABL	<b>TIMER</b>	TIMER	_____	DISABL	
	ACCUTUNE	_____	DISABL		PERIOD	_____	0:01	
	AT ERR	Read only	—		START	_____	KEY	
	PROP BD	_____	1.0		LDISPLAY	_____	TREM	
	or				RESET	_____	KEY	
	GAIN	_____	1.0		ON-TIME	_____	—	
	RATE MIN	_____	0.00		INCRMENT	_____	MIN	
	RSET MIN	_____	1.0					
	or				<b>ALARM 1</b>	A1S1 VAL	_____	90
	RSET RPM	_____	1.0		A1S2 VAL	_____	95	
	MAN RSET	_____	0.0		A1S1TYPE	_____	INPUT1	
	CYCSEC	_____	20.0		A1S2TYPE	_____	INPUT1	
	PROP BD2	_____	1.0		A1S1 H L	_____	LO	
	or				A1S1SCAL	_____	1	
	GAIN 2	_____	1.0		A1S2 H L	_____	HI	
	RATE2MIN	_____	0.00		A1S2SCAL	_____	1	
	RSET2MIN	_____	1.0		AL1 HYST	_____	0.1	
	or				<b>ALARM 2</b>	A2S1 VAL	_____	90
	RSET2RPM	_____	1.0		A2S2 VAL	_____	95	
	CYC2SEC	_____	20.0		A2S1TYPE	_____	INPUT1	
			A2S2TYPE		_____	INPUT1		
<b>SP RAMP1</b>	SP RAMP	_____	DISABL		A2S1 H L	_____	LO	
	TIME MIN	_____	0		A2S1SCAL	_____	1	
	FINAL SP	_____	100.0	A2S2 H L	_____	HI		
	SP RATE	_____	DISABL	A2S2SCAL	_____	1		
	EU/HR UP	_____	—	AL2 HYST	_____	0.1		
	EU/HR DN	_____	—					
	SP PROG	_____	DISABL	<b>ALARM 3</b>	A3S1 VAL	_____	90	
	RECYCLES	_____	—	A3S2 VAL	_____	95		
	SOAK DEV	_____	—	A3S1TYPE	_____	INPUT1		
	PROFILE	_____	—	A3S2TYPE	_____	INPUT1		
	STATE	_____	—	A3S1 H L	_____	LO		
	RECOVERY	_____	—	A3S1SCAL	_____	1		
	PROG END	_____	—	A3S2 H L	_____	HI		
				A3S2SCAL	_____	1		
				AL3 HYST	_____	0.1		
<b>SP RAMP2</b>	SP RAMP	_____	DISABL	<b>ALARM 4</b>	A4S1 VAL	_____	90	
	TIME MIN	_____	0	A4S2 VAL	_____	95		
	FINAL SP	_____	100.0	A4S1TYPE	_____	INPUT1		
	SP RATE	_____	—	A4S2TYPE	_____	INPUT1		
	EU/HR UP	_____	—	A4S1 H L	_____	LO		
	EU/HR DN	_____	—	A4S1SCAL	_____	1		
	SP PROG	_____	DISABL	A4S2 H L	_____	HI		
	RECYCLES	_____	—	A4S2SCAL	_____	1		
	SOAK DEV	_____	—	AL4 HYST	_____	0.1		
	PROFILE	_____	—					
	STATE	_____	—					
	RECOVERY	_____	—					
	PROG END	_____	—					
<b>PROFILES</b>	PRx STRT	_____	—					
	PRx END	_____	—					
	RAMPUNIT	_____	—					
	SYNC 1+2	_____	—					
<b>SPP SEGS</b>	SEGxRAMP	_____	—					
	SEGx SP	_____	—					
	SEGxTIME	_____	—					
<b>SPP EVNT</b>	SEGx EV	_____	—					



Group Prompt	Function prompt	Value or Selection	Factory Setting	Group Prompt	Function prompt	Value or Selection	Factory Setting
<b>ALARM 5</b>	A5S1 VAL	_____	90	<b>EVNT MSG</b>	EVENT 1	_____	NONE
	A5S2 VAL	_____	95		MESSAGE1	_____	EVENT1
	A5S1TYPE	_____	INPUT1		POSITION1	_____	87.3
	A5S2TYPE	_____	INPUT1		EVENT 2	_____	NONE
	A5S1 H L	_____	LO		MESSAGE2	_____	EVENT2
	A5S1SCAL	_____	1		POSITION2	_____	85.5
	A5S2 H L	_____	HI		EVENT 3	_____	NONE
	A5S2SCAL	_____	1		MESSAGE3	_____	EVENT3
AL5 HYST	_____	0.1	POSITION3		_____	83.6	
<b>ALARM 6</b>	A6S1 VAL	_____	90		EVENT 4	_____	NONE
	A6S2 VAL	_____	95		MESSAGE4	_____	EVENT4
	A6S1TYPE	_____	INPUT1		POSITION4	_____	80.0
	A6S2TYPE	_____	INPUT1		EVENT 5	_____	NONE
	A6S1 H L	_____	LO		MESSAGE5	_____	EVENT5
	A6S1SCAL	_____	1		POSITION5	_____	78.2
	A6S2 H L	_____	HI		EVENT 6	_____	NONE
	A6S2SCAL	_____	1	MESSAGE6	_____	EVENT6	
AL6 HYST	_____	0.1	POSITION6	_____	76.9		
<b>AUX OUT</b>	AUX OUT	_____	DISABL	<b>LOCKOUT</b>	PASSWORD	_____	XXXX
	4 mA VAL	_____	0.0		LOCKOUT	_____	CALIB
	20mA VAL	_____	100.0		CHANGE	_____	XXXX
<b>AUX OUT2</b>	AUX OUT2	_____	DISABL	<b>ADJUST</b>	TRACE LN	_____	MEDIUM
	4 mA VAL	_____	0.0		GRID LN	_____	MEDIUM
	20mA VAL	_____	100.0		PEN TYPE	_____	NORMAL
<b>AUX OUT3</b>	AUX OUT3	_____	DISABL				
	4 mA VAL	_____	0.0				
	20mA VAL	_____	100.0				
<b>COMM</b>	ComSTATE	_____	DISABL				
	Com ADDR	_____	1				
	BAUD	_____	9600				
	XMT DLAY	_____	NONE				
	DBL BYTE	_____	FP B				
<b>OPTIONS</b>	REJ FREQ	_____	60				
	HF REJ	_____	ENABLE				
	RELHUMID	_____	NO				
	ATMPRES	_____	—				
	DEVIATION	_____	NONE				
	DEVSETPT	_____	0				
	SCROLL	_____	NONE				
	GRANDTOT	_____	DISABL				



## 4. Configuration Parameter Definitions

### 4.1 Overview

#### Introduction

This section provides information for all the user-configurable control parameters listed in the configuration section. If you aren't familiar with these parameters, this section gives you the parameter prompt, the selection or range of setting that you can make, and a definition of how each parameter setting affects recorder performance. It will also refer you to any other prompts that might be affected by your selection.

#### Parameter groups and prompts

- The control information is found in three configuration groups which are accessed by the **SET UP** key.
- Each of these groups contains prompts, viewed in the lower display, which deal with functions that are pertinent to that particular group. These are accessed by pressing the **FUNC** key.
- The selections or values are listed in the upper display. Refer to *Section 3 - Configuration* for step by step instructions.

#### What's in this section?

The table below lists the topics that are covered in this section. They are listed in the order of their appearance in the recorder.

	Topic	See Page
4.1	Overview	93
4.2	Input Parameters Set Up Group	94
4.3	Pen Parameters Set Up Group	98
4.4	Chart Parameters Set Up Group	100
4.5	Time Parameters Set Up Group	103
4.6	Total Parameters Set Up Group	104
4.7	Input Algorithm Set Up Group	106
4.8	Control Parameters Set Up Group	109
4.9	Tuning Parameters Set Up Group	119
4.10	Setpoint Ramp Set Up Group	122
4.11	Timer Set Up Group	124
4.12	Alarms Set Up Group	125
4.13	Auxiliary Output Set Up Group	128
4.14	Modbus Communications Set Up Group	130
4.15	Options Set Up Group	131
4.16	Event Message Set Up Group	133
4.17	Lockout Parameters Set Up Group	134
4.18	Printing Characteristics Adjustments	135

## 4.2 Input Parameters Set Up Group

### Introduction

These are the parameters required for input 1, 2, 3, or 4; temperature units, decimal location, actuation, transmitter characterization, high and low range values in engineering units, input compensation, filter, and burnout.

### Input group prompts

Table 4-1 lists all the function prompts in the Input 1, 2, 3, or 4 setup group and their definitions.

**Table 4-1 Input Group Definitions**

Lower Display Prompt	Upper Display Range of Setting or Selection	Parameter Definition
<b>DECIMAL</b>	XXXX XXX.X XX.XX X.XXX	<b>DECIMAL POINT LOCATION</b> -- This selection determines where the decimal point appears in the display.  None One Place Two Places Three Places  NOTE: Auto-ranging will occur when one decimal position has been selected and the value increases above 999.9 but auto-ranging <i>will not</i> similarly occur when two decimal positions are selected.
<b>UNITS</b>	DEG F DEG C EU	<b>TEMPERATURE UNITS</b> -- This selection will be indicated on the PV display.  If you select EU, go to prompt "ENGUNITS"  Degrees Fahrenheit Degrees Celsius Engineering Units
<b>ENGUNITS</b>	0 to 9 A to Z + - / (blank)	<b>ENGINEERING UNITS</b> – Make up 5 selections to create unit identifier.  <ul style="list-style-type: none"> <li>For example, create unit identifier H<sub>2</sub>O by selecting an "H" from A to Z, a "2" from 0 to 9, and an "O" from A to Z.</li> <li>For alphanumeric entries, the display will cycle, from left to right, with highlighting (increased brightness) of each digit. The value of each digit can be changed only when it is highlighted.</li> </ul>

Lower Display Prompt	Upper Display Range of Setting or Selection	Parameter Definition
<p><b>INn TYPE</b> (n = 1, 2, 3, or 4)</p>	<p>B TC E TC H E TC L J TC H J TC L K TC H K TC L NNM TC<sup>1</sup>  NIC TC<sup>1</sup>  R TC<sup>1</sup> S TC T TC H T TC L W TC H<sup>1</sup>  W TC L<sup>1</sup>  100 PT 200 HI<sup>2</sup> 200 LO<sup>2</sup> 500 PT 100 RH 4-20mA 0-10mV 10-50m 0-5 V 0-10 V RADIAM</p>	<p><b>INPUT ACTUATION TYPE</b> -- This selection determines what actuation you are going to use for input one. Be sure that the values configured for high and low chart range, soak setpoint, alarm setpoint, etc. are within the measuring range for the selected actuation type.</p> <p>B thermocouple      105 to 3300°F      41 to 1815°C E thermocouple high -454 to 1832°F      -270 to 1000°C E thermocouple low -200 to 1100°F      -129 to 593°C J thermocouple high    0 to 1600°F      -18 to 871°C J thermocouple low    20 to 770°F      -7 to 410°C K thermocouple high -320 to 2500°F      -196 to 1371°C K thermocouple low -20 to 1000°F      -29 to 538°C NNM NiNiMo   thermocouple      32 to 2500°F      0 to 1371°C NIC Nicrosil-Nisil   thermocouple      0 to 2372°F      -178 to 1300°C R thermocouple      0 to 3100°F      -18 to 1704°C S thermocouple      0 to 3100°F      -18 to 1704°C T thermocouple high -300 to 700°F      -184 to 371°C T thermocouple low -200 to 500°F      -129 to 316°C W5W26 thermocouple   high      0 to 4200°F      -18 to 2316°C W5W26 thermocouple   low      0 to 2240°F      -18 to 1227°C 100 Ohm-RTD      -300 to 1200°F      -184 to 649°C 200 Ohm-RTD      32 to 752      0 to 400 200 Ohm-RTD      32 to 392      0 to 200 500 Ohm-RTD      -300 to 900°F      -184 to 482°C 100 Ohm-RTD      -130 to 392°F      -90 to 200°C 4 to 20 Milliamps<sup>3</sup> 0 to 10 Millivolts<sup>3</sup> 10 to 50 Millivolts<sup>3</sup> 0 to 5 Volts<sup>3</sup> 0 to 10 Volts<sup>3</sup> Radiamatic      1400 to 3400°F      760 to 1871°C</p> <p><sup>1</sup>Only available with Model DR45AT <sup>2</sup>Only available with Model DR45AR <sup>3</sup>Go to prompt "XMITTER" to characterize the input.</p>

Lower Display Prompt	Upper Display Range of Setting or Selection	Parameter Definition
<p><b>XMITTER</b></p>	<p>B TC            E TC H            E TC L            J TC H            J TC L            K TC H            K TC L            NNM H            NIC TC            R TC            S TC            T TC H            T TC L            W TC H            W TC L            100 PT            500 PT            100 RH            LINEAR            SQROOT</p>	<p><b>TRANSMITTER CHARACTERIZATION</b> — This selection lets you instruct the recorder to characterize a linear input to represent a nonlinear one.</p> <ul style="list-style-type: none"> <li>NOTE: Prompt only appears when a linear actuation is selected at prompt 'IN1 TYPE'.</li> <li>FOR EXAMPLE: If input 1 is a 4 to 20 mA signal, but the signal represents a type "K" thermocouple; select "K TC H" and the recorder will characterize the 4 to 20 mA signal so that it is treated as a type "K" thermocouple input (high range).</li> </ul> <p>B Type Thermocouple            E Type Thermocouple High            E Type Thermocouple Low            J Type Thermocouple High            J Type Thermocouple Low            K Type Thermocouple High            K Type Thermocouple Low            NNM NiNiMo Type Thermocouple High            NIC Nicrosil Nilil Thermocouple            R Type Thermocouple            S Type Thermocouple            T Type Thermocouple High            T Type Thermocouple Low            W5W26 Type Thermocouple High            W5W26 Type Thermocouple Low            100 Ohm-RTD            500 Ohm-RTD            100 Ohm -RTD            Linear Range            Extracts Square Root</p>
<p><b>INn HI</b>            (n = 1, 2, 3, or 4)</p>	<p>–999.9 to 9999.            or            –999 to 9999            in engineering units</p>	<p><b>INPUT HIGH RANGE VALUE</b> in engineering units is displayed for all inputs but can only be configured for linear or square root transmitter characterization. Otherwise, this is a read-only display of the higher range value for the selected T/C or RTD input including transmitter characterization, if applicable.</p> <ul style="list-style-type: none"> <li>Scale the #1 input signal to the display value you want for 100 %.</li> <li><b>EXAMPLE:</b>            Actuation (Input) = 4 mA to 20 mA            Process Variable = Flow            Range of Flow = 0 to 250 Gal/Min            High Range display value = 250            Then 20 mA = 250 Gal/Min</li> </ul> <p>The control setpoint will be limited by the range of units selected here.</p>

Lower Display Prompt	Upper Display Range of Setting or Selection	Parameter Definition
<p><b>INn LO</b> (n = 1, 2, 3, or 4)</p>	<p>–999.9 to 9999. or –999 to 9999 in Engineering units</p>	<p><b>INPUT LOW RANGE VALUE</b> in engineering units is displayed for all inputs but can only be configured for linear or square root transmitter characterization.</p> <ul style="list-style-type: none"> <li>• Otherwise, this is a read-only display of the low range value for the selected T/C or RTD input including transmitter characterization, if applicable.</li> <li>• Scale the input signal to the display value you want for 0 %. See example on previous page. The control setpoint for Input will be limited by the range of units selected here.</li> </ul>
<p><b>CUTOFF n</b> (n = 1, 2, 3, or 4)</p>	<p>0 to 100 % of Input Range</p>	<p><b>LOW FLOW CUTOFF</b>—Lets you set a value in percent of range below which the applicable totalizer does not increment.</p> <p><b>ATTENTION</b> Prompt appears only if totalizer option is present in the recorder.</p>
<p><b>INPTCOMP</b></p>	<p>–999.9 to 9999.</p>	<p><b>INPUT COMPENSATION</b> — used to compensate the input for drift of an input value due to deterioration of a sensor, or some other cause; select the value you want on the input.</p>
<p><b>FILTER n</b> (n = 1, 2, 3, or 4)</p>	<p>0 to 120 seconds No filter = 0</p>	<p><b>FILTER FOR INPUT</b> — a software digital filter is provided for the input to smooth the input signal. You can configure the first order lag time constant from 1 to 120 seconds. If you do not want filtering, enter 0.</p>
<p><b>BURNOUT</b></p> <p>NONE</p> <p>UP</p> <p>DOWN</p>		<p><b>BURNOUT PROTECTION (SENSOR BREAK)</b> provides most input types with upscale or downscale protection if the input fails.</p> <ul style="list-style-type: none"> <li>• Not available for inputs 0-5 V, 0-10 V, or 4-20 mA.</li> </ul> <p><b>NO BURNOUT</b> — Failsafe output applied for failed input.</p> <p><b>UPSCALE BURNOUT</b> will make the indicated PV signal increase when a sensor fails, and flash the upper display.</p> <p><b>DOWNSCALE BURNOUT</b> will make the indicated PV signal decrease when a sensor fails, and flash the upper display.</p> <p>NOTE: For no Burnout (that is, “None”) to function properly on a linear input, there must be a dropping resistor directly across the <i>input</i> terminals (that is, not remote), then the unit can detect the “zero” voltage that occurs when the 4-20 mA line is opened.</p>
<p><b>EMISSIV</b></p>	<p>.01 to 1.00</p>	<p><b>EMISSIVITY</b> is a correction factor applied to the Radiamatic input signal that is the ratio of the actual energy emitted from the target to the energy which would be emitted if the target were a perfect radiator. Available only for “Radiamatic” inputs.</p>

*Repeat the procedure for INPUT 2, INPUT 3, and INPUT 4 configuration.*

## 4.3 Pen Parameters Set Up Group

### Introduction

The functions listed in this group deal with how to configure pen #1, pen #2, pen #3, or pen #4. The procedure for configuring each pen is the same. The prompts shown in Table 4-2 show PEN 1.

- Press the **SET UP** key until PEN 1, PEN 2, PEN 3, or PEN 4 appears in the display.

### Pen 1-2-3-4 group prompts

Table 4-2 lists all the function prompts in the Pen 1, 2, 3, 4 set up groups and their definitions.

**Table 4-2 Pen 1, 2, 3, or 4 Group Definitions**

Lower Display Prompt	Upper Display Range of Setting or Selection	Parameter Definition
<b>PENn</b> (n = 1, 2, 3 or 4)	ENABLE DISABL	<b>PEN RECORD</b> —This selection lets you enable or disable the pen (channel) record  <ul style="list-style-type: none"> <li>• Remember, the lower display prompt could read PEN2, PEN3, or PEN4.</li> </ul>
<b>PENnIN</b> (n = 1, 2, 3 or 4)	INPUT 1 INPUT 2 INPUT 3 INPUT 4  RH  OUTPT1 OUTPT2 SETPT1 SETPT2 DGTL1  DGTL2  PV1	<b>PEN INPUT</b> —What do you want the pen to record?  <b>INPUT 1</b> —records Input 1 <b>INPUT 2</b> —records Input 2 <b>INPUT 3</b> —records Input 3 <b>INPUT 4</b> —records Input 4  <b>RELATIVE HUMIDITY</b> —records in % RH. It initiates an external calculation for measuring relative humidity. INPUT 1, IN TYP must be configured for 100 PT. INPUT 2, IN TYP must be configured for 100 RH. The RH prompt only appears when RELHUMID prompt in the OPTIONS group is configured as YES. <b>OUTPUT 1</b> —records Output 1 <b>OUTPUT 2</b> —records Output 2 <b>SETPOINT 1</b> —records Setpoint 1 <b>SETPOINT 2</b> —records Setpoint 2 <b>DIGITAL 1 INPUT</b> —records EVENT pen function on contact closure across digital 1 input. <b>DIGITAL 2 INPUT</b> —records EVENT pen function on contact closure across digital 2 input. <b>PV1</b> —records calculated PV1 when an input algorithm (INP ALG) has been selected in the Options group. (Available only in units with software Math Option.)
<b>CHARTnHI</b> (n = 1, 2, 3 or 4)	–999.0 to 999	<b>CHART HIGH RANGE VALUE</b> —Enter a value that corresponds with the chart high range value for pen 1 (pen 2, pen 3, or pen 4).
<b>CHARTnLO</b> (n = 1, 2, 3 or 4)	–999.0 to 999	<b>CHART RANGE LOW VALUE</b> —Enter a value that corresponds with the chart low range value for pen 1 (pen 2, pen 3, or pen 4).



Lower Display Prompt	Upper Display Range of Setting or Selection	Parameter Definition												
<b>PENnON</b> (n = 1, 2, 3 or 4)	0 to 100 %	<p><b>PEN CHART POSITION FOR ON EVENT</b> — This is the event marker configuration using digital inputs. Select the chart position where pen 1 (pen 2, pen 3, and pen 4) is to mark (trace) occurrence of an ON event.</p> <ul style="list-style-type: none"> <li>Prompt only appears if DGTL1 or 2 is selected as pen 1 (pen 2, pen 3, or pen 4) input.</li> </ul>												
<b>PENnOFF</b> (n = 1, 2, 3 or 4)	0 to 100 %	<p><b>PEN CHART POSITION FOR OFF EVENT</b> — This is the event marker configuration using digital inputs. Select the chart position where Pen 1 (pen 2, pen 3, and pen 4) is to mark (trace) occurrence of an OFF event.</p> <ul style="list-style-type: none"> <li>Prompt only appears if DGTL1 or 2 is selected as pen 1 (pen 2, pen 3, or pen 4) input.</li> </ul>												
<b>MAJORDIV</b>	2 to 10	<p><b>MAJOR CHART DIVISIONS</b> — This is the number of Major Divisions in range of chart 1 (2, 3, or 4) scale (between CHART1HI and CHART1LO). Must divide evenly into chart range.</p> <p><b>ATTENTION</b> The values of major divisions are now printed with decimal points when possible. The restriction is four characters, including the decimal and (-) sign.</p> <p>EXAMPLES:</p> <table border="1"> <thead> <tr> <th>Pen Range</th> <th>Print Format</th> </tr> </thead> <tbody> <tr> <td>0 to 99</td> <td>XX.X</td> </tr> <tr> <td>0 to 9</td> <td>X.XX</td> </tr> <tr> <td>-9 to 9</td> <td>XX.X</td> </tr> <tr> <td>-99 to 99</td> <td>XXX</td> </tr> <tr> <td>0 to 999</td> <td>XXX</td> </tr> </tbody> </table>	Pen Range	Print Format	0 to 99	XX.X	0 to 9	X.XX	-9 to 9	XX.X	-99 to 99	XXX	0 to 999	XXX
Pen Range	Print Format													
0 to 99	XX.X													
0 to 9	X.XX													
-9 to 9	XX.X													
-99 to 99	XXX													
0 to 999	XXX													
<b>MINORDIV</b>	2 to 10	<p><b>MINOR CHART DIVISIONS</b> — This is the number of Minor Divisions in range of chart 1 (2, 3, or 4) scale (increments in each Major Division).</p>												
<b>RNGnTAG</b> (n = 1, 2, 3 or 4)	0 to 9 A to Z + - / (blank)	<p><b>RANGE 1 TAG NAME</b> — Enter a tag name for chart 1 (2, 3, or 4) range. It can be up to 5 characters.</p> <ul style="list-style-type: none"> <li>For alphanumeric entries, the display will cycle, from left to right, with highlighting (increased brightness) of each digit. The value of each digit can only be changed when it is highlighted.</li> </ul>												

*Repeat this procedure for PEN 2, PEN 3, and PEN 4 configuration.*

## 4.4 Chart Parameters Set Up Group

### Introduction

The functions listed in this group deal with how the chart will be set up. It includes time divisions, speed, name, rotation, header, remote activation, and wake time parameters that have to be set for the proper chart function.



#### CAUTION

Before making any configuration changes to the “Chart” Set Up group, place the recorder in “Chart Hold”. Press the **CHART** key to stop the chart rotation. Press again after configuration entry is made.

### Chart group prompts

Table 4-3 lists all the function prompts in the chart parameters setup group and their definitions.

**Table 4-3 Chart Parameters Group Definitions**

Lower Display Prompt	Upper Display Range of Setting or Selection	Parameter Definition
<b>CHRTSPD</b>	8HR 12HR 24HR 7DAYS XHR	<p><b>CHART SPEED</b> — This is the time it will take to drive the chart one complete revolution.</p> <p>8 Hour revolution 12 Hour revolution 24 Hour revolution 7 Day revolution X hour revolution - make Hours per Revolution selection at prompt “HOUR/REV”.</p> <p><b>ATTENTION</b> If the chart speed selection is 8 hr/8 division, 12 hr/12 division, 24 hr/24 division, 7 day/14 division, or 7 day/21 division, then standard chart has been selected.</p> <p>This means that the chart will be printed with the time lines on the hour. Limited information will be printed on the chart during the first incomplete segment following chart initiation and before the first valid hour mark.</p> <p>NOTE: If X hour chart is selected, standard charts are disabled.</p>
<b>HOUR/REV</b>	6 to 744 Hours (12 hrs for abrasion resistant pen)	<p><b>HOURS PER REVOLUTION</b> — Set the desired chart speed. Appears only if XHR was selected at prompt “CHRT SPD”.</p> <p><b>ATTENTION</b> Below 8-hour chart speed (24 hours with abrasion resistant pen) printing may be degraded.</p>

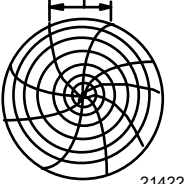
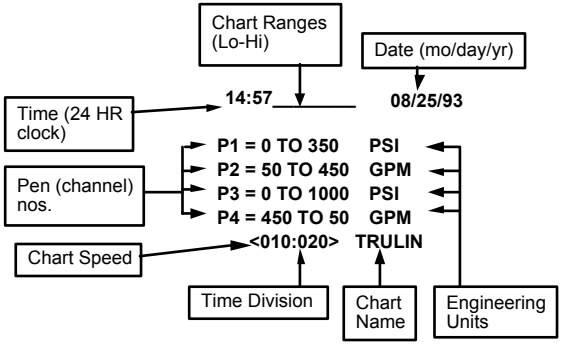
Lower Display Prompt	Upper Display Range of Setting or Selection	Parameter Definition
<p><b>TIME DIV MAJOR</b></p> <p><b>TIME DIV MINOR</b></p>	<p>8 to 24 time periods</p> <p>Software set for 4 or 8 seg/minor time divisions</p>	<p><b>TIME DIVISION</b> — This is the number of time periods into which the chart record is to be divided.</p> <p style="text-align: center;"><b>TIME PERIOD</b></p> <p style="text-align: center;"></p> <p><b>ATTENTION</b> Make sure that the chart selected is evenly divisible into the time periods. For example: 7 day = 14 or 21 lines.</p>
<p><b>CONTINUE</b></p>	<p>YES NO</p>	<p><b>CONTINUE CHART ROTATION</b> — Do you want to continue or stop the chart drive after a single 360° rotation.</p> <p>Yes—continue chart drive No—stop chart drive (If "NO" is selected, chart paper must be replaced for proper printout.)</p>
<p><b>CHARTNAM</b></p>	<p>0 TO 9 A TO Z + - / (BLANK)</p>	<p><b>CHART NAME</b> - This is where you determine the chart name identifier. For example: TRULINE/4.</p> <ul style="list-style-type: none"> <li>For alphanumeric entries, the display will cycle, from left to right, with highlighting (increased brightness) of each digit.</li> <li>The value of each digit can be changed only when it is highlighted.</li> </ul>
<p><b>HEADER</b></p>	<p>YES NO</p>	<p><b>HEADER FOR CHART</b> – Is the header to be printed each time the recorder goes from chart hold to chart run the <b>CHART</b> key is pressed.</p> <p style="text-align: center;"><b>HEADER EXAMPLE</b></p> <p style="text-align: center;"></p> <p>• If you select "NO" only the chart name will be printed.</p>

Lower Display Prompt	Upper Display Range of Setting or Selection	Parameter Definition
<p><b>REM CHRT</b></p>	<p>NONE            EXT SW1            EXT SW2            ALARM 1            ALARM 2            TIME            ALARM 3            ALARM 4            ALARM 5            ALARM 6</p>	<p><b>REMOTE CHART ACTIVATION</b> – Select the desired function to activate the chart from a remote location or an internal signal.</p> <p><b>NONE</b> - No selection  <b>EXT SW 1</b> - External Switch #1 activates chart (Digital Input #1)  <b>EXT SW 2</b> - External Switch #2 activates chart (Digital Input #2)  <b>ALARM 1</b> - Alarm 1 activates chart  <b>ALARM 2</b> - Alarm 2 activates chart  <b>TIME</b> - Wake Time activates chart  <b>ALARM 3</b> - Alarm 3 activates chart  <b>ALARM 4</b> - Alarm 4 activates chart  <b>ALARM 5</b> - Alarm 5 activates chart  <b>ALARM 6</b> - Alarm 6 activates chart</p> <ul style="list-style-type: none"> <li>If you select "TIME", set wake minutes at prompt "WAKE MIN" and wake hours at prompt "WAKE HR" in Time Set Up group.</li> </ul>

## 4.5 Time Parameters Set Up Group

### Introduction

The functions listed in this group deal with how to configure the real-time in minutes, hours, days, months, and years. There is also a selection for days of the week.

### Time group prompts

Table 4-4 lists all the function prompts in the Time parameters setup group and their definitions.

**Table 4-4 Time Parameters Group Definitions**

Lower Display Prompt	Upper Display Range of Setting or Selection	Parameter Definition
MINUTES	0 to 59	<b>REAL-TIME IN MINUTES</b> — Set the present time in minutes.
HOURS	0 to 23	<b>REAL-TIME IN HOURS</b> — Set the hour in 24 HR clock format.
DAY	1 to 31	<b>REAL-TIME IN DAYS</b> — Set a number corresponding to a day.
MONTH	1 to 12	<b>REAL-TIME IN MONTHS</b> — Set a number corresponding to a month.
YEAR	0 to 99	<ul style="list-style-type: none"> <li><b>REAL-TIME IN YEARS</b> — Set a number corresponding to a year.</li> </ul>
DAY	MONDAY TUESDAY WEDDAY THURDAY FRIDAY SATDAY SUNDAY	<ul style="list-style-type: none"> <li><b>DAY OF THE WEEK</b> — Select a day of the week.</li> </ul>
WAKE MIN	0 to 59	<b>WAKE MINUTES</b> – Wake time specifies time, in minutes, at which Wake Time Event occurs.
WAKE HR	0 to 23	<b>WAKE HOUR</b> – Wake time specifies time, in hours, at which Wake Time Event occurs.
WAKE DAY	0 to 31	<p><b>WAKE DAY</b> – Wake time specifies time, in days, at which Wake Time Event occurs.</p> <p><b>ATTENTION</b> If day is set to “0”, the wake up day and month are ignored and only a successful match of the hours and minutes will cause the event.</p>
WAKE MON	1 to 12	<b>WAKE MONTH</b> – Wake time specifies time, in months, at which Wake Time Event occurs.

## 4.6 Total Parameters Set Up Group

### Introduction

The functions listed in this group deal with the calculation and display of the total flow volume as measured by Input 1 (Total 1), or Input 2 (Total 2). The displayed value is eight digits with a configurable scale factor.

### Totalizer 1 and 2 group prompts

Table 4-5 lists all the function prompts in the Totalizer 1 and 2 Set Up group and their definitions.

**Table 4-5 Totalizer Group Definitions**

Lower Display Prompt	Upper Display Range of Setting or Selection	Parameter Definition
(Actual Current totalized value)	(Current scale factor)  Example: E1 GPM	<b>VIEW CURRENT TOTALIZED VALUE</b> — this selection lets you view the current totalized value. <ul style="list-style-type: none"> <li>In the example shown, E1 represents exponential value of total (total times <math>10^1</math>). GPM represents total engineering units selected.</li> <li>See “SCALER” and “TOTAL EU” function prompts in this group for selections.</li> </ul>
<b>RSETTOT</b>	YES NO	<b>RESET TOTALIZER TO ZERO</b> — this selection lets you reset the totalizer to zero. <ul style="list-style-type: none"> <li>Selecting YES will reset the totalizer to zero.</li> </ul> Function prompt “RSETABLE” must be set to “LOCAL”.
<b>TOTAL1 TOTAL2</b>	DISABL, INPUT 1, INPUT 2, INPUT 3, INPUT 4, PV1, E TIME	<b>TOTALIZATION FOR INPUT 1 OR 2</b> — this selection allows you to select the input to Totalizer 1 or 2. <ul style="list-style-type: none"> <li>E TIME accumulates elapsed time since last reset in the units specified under RATE function.</li> <li>Not DISABL allows selection of the rest of the prompts associated with totalization.</li> </ul>
<b>TOTALEU</b>	0 to 9 A to Z + - / (blank)	<b>TOTAL ENGINEERING UNITS</b> — this selection allows you to make up to 3 selections to create a unit identifier that the total represents. <ul style="list-style-type: none"> <li>For alphanumeric entries, the display will cycle, from left to right, with highlighting (increased brightness) of each digit. The value of each digit can be changed only when it is highlighted.</li> </ul>

Lower Display Prompt	Upper Display Range of Setting or Selection	Parameter Definition
<b>RATE</b>	SECOND MINUTE HOUR DAY M/DAY	<p><b>RATE OF INTEGRATION</b> — This selection allows you to select the desired rate of integration. It must match input units:</p> <p>Example:</p> <p>GPM must use "MINUTE" PPH must use "HOUR"</p> <p><b>SECOND</b> - EU (Engineering Units) per second. <b>MINUTE</b> - EU per minute <b>HOUR</b> - EU per hour <b>DAY</b> - EU per day <b>M/DAY</b> - Millions of Units per day (multiplier) <math>10^6</math> x input</p>
<b>SCALER</b>	1 10 100 1000 10000 100000 1E6	<p><b>TOTALIZER SCALE FACTOR</b> — this selection allows you to select a scale factor (that is, a Multiplier) for the totalizer display. It affects only the display.</p> <ul style="list-style-type: none"> <li>The desired factor is applied to the calculated value to extend the maximum flow range that can be displayed.</li> <li>Scaler selection does not affect the totalization value printed on the chart.</li> </ul> <p><b>EXAMPLE:</b></p> <ul style="list-style-type: none"> <li>1E6 equals 1 times <math>10^6</math>. (1,000,000)</li> </ul>
<b>RSETABLE</b>	NO LOCAL  EXT SW1  EXT SW2  TIME	<p><b>LOCAL TOTALIZER RESET</b>— Allows the totalizer value to be reset via the display/keypad.</p> <p><b>EXTERNAL SWITCH 1</b>—Allows the totalizer to be set to zero upon switch #1 closure. (Digital Input #1)</p> <p><b>EXTERNAL SWITCH 2</b>—Allows the totalizer to be set to zero upon switch #2 closure. (Digital Input #2)</p> <p><b>WAKE TIME</b>—Resets the totalizer when the value configured for the Wake Time Event is reached. (See WAKE MIN, WAKE HR, WAKE DAY, WAKE MON in the Time Set Up group.)</p>
<b>INHIBIT</b>	NONE S1 OPEN S1 CLOSE S2 OPEN S2 CLOSE	<p>The totalizer will be inhibited while the configured action is true.</p> <p>External SW1 open inhibits totalizer. External SW1 closed inhibits totalizer. External SW2 open inhibits totalizer. External SW2 closed inhibits totalizer.</p>

*Repeat the configuration for TOTAL 2.*

## 4.7 Input Algorithm Set Up Group

### Introduction

The Input Algorithm Set Up Group lets you apply various math algorithms to the inputs.

### Prompts

Table 4-6 lists all the function prompts in the Input Algorithm set up group and their functions.

**Table 4-6 Input Algorithm Group Definitions**

Lower Display Prompt	Upper Display Range of Setting or Selection	Parameter Definition
INP ALG		<b>INPUT ALGORITHM</b> has the following selections from which to choose:  <b>ATTENTION</b> If the input is disabled, the corresponding term is set to 1 except if the Summer (A+B+C) is selected in which case the term is set to 0. The calculated PV1 can be the pen 1-4 source as well as the input to totalizer 1. The ratio and bias values are still applied so that the term corresponding to the unused input can be made into any constant value.
	NONE	<b>NONE</b> —No algorithm configured
	A+B+C (NOTE 1)	<b>SUMMER WITH RATIO AND BIAS</b> —The following formula applies:  $PV = K \times (\text{Input 1} \times \text{Ratio A} + \text{Bias A}) + (\text{Input 2} \times \text{Ratio B} + \text{Bias B}) + (\text{Input 3} \times \text{Ratio C} + \text{Bias C})$
	$\sqrt{A \cdot B/C}$ (NOTE 1)	<b>MULTIPLIER DIVIDER WITH SQUARE ROOT</b> —The following formula applies:  $PV = K \times \text{Error!} \times (PV_{HI} - PV_{LO})$
	$\sqrt{A \cdot B \cdot C}$ (NOTE 1)	<b>MULTIPLIER WITH SQUARE ROOT</b> —The following formula applies:  $PV = K \times \text{Error!} \times (PV_{HI} - PV_{LO})$
	A*B/C (NOTE 1)	<b>MULTIPLIER DIVIDER</b> —The following formula applies:  $PV = K \times \text{Error!} \times (PV_{HI} - PV_{LO})$
	A*B*C (NOTE 1)	<b>MULTIPLIER</b> —The following formula applies:  $PV = K \times (\text{Input 1} \times \text{Ratio A} + \text{Bias A}) \times (\text{Input 2} \times \text{Ratio B} + \text{Bias B}) \times (\text{Input 3} \times \text{Ratio C} + \text{Bias C}) \times (PV_{HI} - PV_{LO})$



Lower Display Prompt	Upper Display Range of Setting or Selection	Parameter Definition
	A-B*C (NOTE 1)	<b>SUBTRACTOR MULTIPLIER</b> —For BTU calculations. The following formula applies:  $PV = Kx [(Input\ 1 \times Ratio\ A + Bias\ A) - (Input\ 2 \times Ratio\ B + Bias\ B)] \times (Input\ 3 \times Ratio\ C + Bias\ C)$
	LO SEL	<b>LOW SELECT</b> —PV is the lower of INPUT 1 or INPUT 2.
	HI SEL	<b>HI SELECT</b> —PV is the higher of INPUT 1 or INPUT 2.
<b>COEFF</b>	0.00 to 99.00	<b>K CONSTANT</b> —Appears only if a selection is made at “INP ALG” prompt.
<b>PV HIGH</b>	–999 to 9999	<b>CALCULATED PV HIGH LIMIT</b> —Only applicable for algorithms “√A*B/C”, “√A*B*C”, “A*B/C”, “A*B*C”.
<b>PV LOW</b>	–999 to 9999	<b>CALCULATED PV LOW LIMIT</b> —Only applicable for algorithms “√A*B/C”, “√A*B*C”, “A*B/C”, “A*B*C”.
<b>RATIO A</b>	–20 to 20	<b>RATIO FOR INPUT 1</b> —Used with the “A” term in the match equation selected at prompt “INP ALG”.
<b>BIAS A</b>	–999 to 9999	<b>BIAS FOR INPUT 1</b> —Used with the “A” term in the math equation selected at prompt “INP ALG”.
<b>RATIO B</b>	–20 to 20	<b>RATIO FOR INPUT 2</b> —Used with the “B” term in the math equation selected at prompt “INP ALG”.
<b>BIAS B</b>	–999 to 9999	<b>BIAS FOR INPUT 2</b> —Used with the “B” term in the math equation selected at prompt “INP ALG”.
<b>RATIO C</b>	–20 to 20	<b>RATIO FOR INPUT 3</b> —Used with the “C” term in the math equation selected at prompt “INP ALG”.
<b>BIAS C</b>	–999 to 9999	<b>BIAS FOR INPUT 3</b> —Used with the “C” term in the math equation selected at prompt “INP ALG”.
<b>POLYNOM</b>	NONE, INPUT 1, INPUT 2, INPUT 3, INPUT 4	<b>POLYNOMIAL EQUATION</b> - A fifth order Polynomial Equation can be used on any one of the four Analog Inputs.  The equation is in the form:
	$Y = C_5 * 10^{-7} X^5 + C_4 * 10^{-5} X^4 + C_3 * 10^{-3} X^3 + C_2 * 10^{-1} X^2 + C_1 X + C_0$ <p>Where:</p> <p>X is the analog input selected in % of span  <math display="block">X\% = \frac{X_{EU}}{Span\ EU} \cdot 100</math></p> <p>C<sub>0</sub> is a value between –99.99 to +99.99            C<sub>1</sub> - C<sub>5</sub> are values between –9.999 to +9.999</p>	
<b>C0 VALUE</b>	–99.99 to 99.99	<b>Polynomial coefficient C0</b>
<b>C1 VALUE</b>	–9.999 to 9.999	<b>Polynomial coefficient C1</b>
<b>C2x10-1</b>	–9.999 to 9.999	<b>Polynomial coefficient C2</b>

<b>Lower Display Prompt</b>	<b>Upper Display Range of Setting or Selection</b>	<b>Parameter Definition</b>
<b>C3x10-3</b>	-9.999 to 9.999	<b>Polynomial coefficient C3</b>
<b>C4x10-5</b>	-9.999 to 9.999	<b>Polynomial coefficient C4</b>
<b>C5x10-7</b>	-9.999 to 9.999	<b>Polynomial coefficient C5</b>

NOTE 1:  $A = (\text{Input 1} \times \text{Ratio A} + \text{Bias A})$   
 $B = (\text{Input 2} \times \text{Ratio B} + \text{Bias B})$   
 $C = (\text{Input 3} \times \text{Ratio C} + \text{Bias C})$   
The order of the inputs are fixed in the equations.

## 4.8 Control Parameters Set Up Group

### Introduction

The functions listed in this group deal with how the DR4500A will control the process including: number of tuning parameter sets, setpoint source, ratio, bias, tracking, power-up recall, setpoint limits, output direction and limits, deadband and hysteresis, control algorithm, output algorithm, and the current duplex range. There are two control groups.

### Control group prompts

Table 4-7 lists all the function prompts in the Control 1 or Control 2 set up groups and their definitions.

**Table 4-7 Control 1 or 2 Group Definitions**

Lower Display Prompt	Upper Display Range of Setting or Selection	Parameter Definition
<b>CONTROL 1</b>	ENABLE DISABL	<b>CONTROL 1</b> — allows you to enable or disable control loop #1.
<b>PID SETS</b>		<b>NUMBER OF TUNING PARAMETER SETS</b> — this selection lets you choose one or two sets of tuning constants (gain, rate, and reset).
	1 ONLY	<b>ONE SET ONLY</b> — only one set of tuning parameters is available. Configure the values for: Gain (proportional band) Rate Reset Time Cycle Time (if time proportional is used)
	2KEYBD	<b>TWO SETS KEYBOARD SELECTABLE</b> — two sets of tuning parameters can be configured and can be selected at the operator interface.  <ul style="list-style-type: none"> <li>Press <b>LOWR DISP</b> key until you see "PID SET1" or "PID SET2" to switch between sets. Configure the values for: Gain, Rate , Reset, Cycle Time Gain #2, Rate #2, Reset #2, Cycle #2 Time</li> </ul>
2PV SW	<b>TWO SETS PV AUTOMATIC SWITCHOVER</b> — when the process variable is <i>GREATER</i> than the value set at prompt "SW VALUE" (Switchover Value), the recorder will use Gain, Rate, Reset, and Cycle Time. The active PID SET can be read in the lower display.  <ul style="list-style-type: none"> <li>When the process variable is <i>LESS</i> than the value set at prompt "SW VALUE," the recorder will use Gain #2, Rate #2, Reset #2, and Cycle #2 Time. The active PID SET can be read in the lower display. Other prompts affected: SW VALUE</li> </ul>	

Lower Display Prompt	Upper Display Range of Setting or Selection	Parameter Definition
<b>PID SETS (continued)</b>	2SP SW	<p><b>TWO SETS SP AUTOMATIC SWITCHOVER</b> — when the setpoint is <i>GREATER</i> than the value set at prompt "SW VALUE" (Switchover Value), the recorder will use Gain, Rate, Reset, and Cycle.</p> <ul style="list-style-type: none"> <li>When the setpoint is <i>LESS</i> than the value set at prompt "SW VALUE," the recorder will use Gain #2, Rate #2, Reset #2, and Cycle #2.</li> <li>Other prompts affected: SW VALUE</li> </ul>
<b>SW VALUE</b>	-999.0 to 9999	<p><b>AUTOMATIC SWITCHOVER VALUE</b> —this is the value of process variable or setpoint at which the recorder will switch from Tuning Constant Set #2 to Set #1. Only appears when PID SETS selections "2PV SW" or "2SP SW" are selected.</p>
<b>SP SOURC</b>		<p><b>SETPOINT SOURCE</b> — this selection determines what your setpoint source will be; One local or Two local. Toggled by the "SETPOINT SELECT" key.</p>
	1LOCAL	<p><b>LOCAL SETPOINT</b> — the setpoint entered from the keyboard or from the setpoint program.</p>
	REMOTE	<p><b>REMOTE SETPOINT</b> — a signal is brought in through the second input printed circuit board connector J2 and used as the control setpoint.</p> <ul style="list-style-type: none"> <li>If you select "REMOTE", Input #3 is automatically assigned as your RSP source for CONTROL #1; INPUT #4 is assigned for CONTROL #2. However, if the unit has only 2 inputs then RSP will be on input 2.</li> <li>Ratio and Bias can be applied to the remote setpoint. Mutually exclusive with 2 Local setpoints.</li> <li>Other prompts affected: RATIO, BIAS.</li> </ul>
	2LOCAL	<p><b>TWO LOCAL SETPOINTS</b> — this selection lets you switch between two local setpoints. Mutually exclusive with Remote setpoint.</p>
	OUT2	<p>Only for Loop 1— Setpoint is the output of Control Loop 2.</p>
<b>RATIO</b>	-20.00 to 20.00	<p><b>RATIO</b> — used when input 2* operates as a remote setpoint, prompt "REMOTE."</p> <ul style="list-style-type: none"> <li>This ratio value can be applied to the remote setpoint. It establishes the correct relationship between the remote setpoint and the input 2 signal applied according to the formula below (under Bias).</li> <li>Input 2 must be enabled.</li> </ul> <p>*For recorders with two controllers, use input 3 for controller #1 and input 4 for controller #2.</p>

Lower Display Prompt	Upper Display Range of Setting or Selection	Parameter Definition
<b>BIAS</b>	-9999 to 9999 (engineering units)	<p><b>BIAS</b> — used when input 2 operates as a remote setpoint (prompt "REMOTE").</p> <ul style="list-style-type: none"> <li>Bias, together with ratio, establishes the correct relationship between the remote setpoint and the input 2 signal applied according to the formula:  <math display="block">\text{REMOTE SETPOINT} = \text{IN2 VALUE (RATIO)} + \text{BIAS}</math> </li> </ul> <p>NOTE: IN2 VALUE = Actual (engineering units)</p> <ul style="list-style-type: none"> <li>All values must be within configured setpoint high and low limits.</li> <li>Input 2 must be enabled.</li> </ul>
<b>SP TRACK</b>		<p><b>SETPOINT TRACKING</b> — the local setpoint can be configured to track the remote setpoint as listed below:</p>
	NONE	<ul style="list-style-type: none"> <li><b>NO TRACKING</b> — if local setpoint tracking is not configured, the LSP will not be altered when transfer from RSP to LSP is made.</li> </ul>
	RSP	<ul style="list-style-type: none"> <li><b>LSP (LOCAL SETPOINT) TRACKS RSP (REMOTE SETPOINT) IN AUTO</b> — if configured, when the recorder transfers out of remote setpoint, the last value of the remote setpoint (RSP) is inserted into the local setpoint.</li> </ul>
<b>POWER UP</b>		<p><b>POWER UP CONTROLLER MODE RECALL</b> — this selection determines which mode and setpoint the recorder will use when the it restarts after a power loss. Select one from below:</p>
	MANUAL	<ul style="list-style-type: none"> <li><b>MANUAL, LSP</b> — at power-up, the recorder will use <i>manual</i> mode with the output value displayed.</li> </ul>
	A LSP	<ul style="list-style-type: none"> <li><b>AUTOMATIC, LOCAL SETPOINT</b> — at power-up, the recorder will return to the <i>automatic</i> mode and will use the local setpoint for control.</li> </ul>
	A RSP	<ul style="list-style-type: none"> <li><b>AUTOMATIC, REMOTE SETPOINT</b> — at power-up, the recorder will return to the <i>automatic</i> mode and will use the remote setpoint for control.</li> </ul>
	AM SP	<ul style="list-style-type: none"> <li><b>LAST MODE, LAST SETPOINT</b> used before power down.</li> </ul>
	AM LSP	<ul style="list-style-type: none"> <li><b>LAST MODE, LAST LOCAL SETPOINT</b> on power down.</li> </ul>
<b>PWR OUT</b>		<p><b>POWER UP OUTPUT SELECTION (for 3P Step Control only)</b> — this selection determines what position the motor will be in when powered up.</p>
	LAST	<p><b>LAST</b> — at power up in automatic mode, the motor position will be the last one prior to power down. When the unit goes into FAILSAFE, it will stay in automatic mode; motor will <b>not</b> be driven to the configured Failsafe position.</p>

Lower Display Prompt	Upper Display Range of Setting or Selection	Parameter Definition
<b>PWR OUT (continued)</b>	FAIL SF	<b>FAIL SF</b> — at power up in manual mode, the motor will be driven to either the 0 % or 100 % output position, whichever is selected at prompt "FAILSAFE". When the unit goes into FAILSAFE, it will go to manual mode; motor will be driven to the configured Failsafe position.
<b>SP HILIM</b>	-999.0 to 9999. input units	<b>SETPOINT HIGH LIMIT*</b> — this selection prevents the local and remote setpoints from going above the value selected here. The setting must be equal to or less than the upper range of input 1 and input 2. Input 2,** when configured for remote setpoint, will be restricted to this upper limit.
<b>SP LOLIM</b>	-999.0 to 9999. inputs units	<b>SETPOINT LOW LIMIT*</b> — this selection prevents the local and remote setpoints from going below the value selected here. The setting must be equal to or greater than the lower range of input 1 and input 2. Input 2,** when configured for remote setpoint, will be restricted to this lower limit.
<b>ACTION</b>		<b>CONTROL OUTPUT DIRECTION</b> — in what direction do you want the recorder output to go when the process variable increases.
	DIRECT	<b>DIRECT ACTING CONTROL</b> — the recorder's output <i>increases</i> as the process variable increases.
	REVRSE	<b>REVERSE ACTING CONTROL</b> — the recorder's output <i>decreases</i> as the process variable increases.
<b>OUTHILIM</b>	-5.0 to 105.0 % of output	<b>HIGH OUTPUT LIMIT</b> — this is the highest value of output beyond which you do not want the recorder automatic output to exceed. Use 0 % to 100 % for time proportional output type.
<b>OUTLOLIM</b>	-5.0 to 105.0 % of output	<b>LOW OUTPUT LIMIT</b> — this is the lowest value of output below which you do not want the recorder automatic output to exceed. Use 0 % to 100 % for time proportional output type.
<b>DROPOFF</b>	-5 to 105.0 % of output	<b>CONTROLLER DROPOFF VALUE</b> — select an output value that below which the recorder output will droppoff to the low output limit value set in prompt "OUT LOLIM."
<b>DEADBAND</b>		<b>DEADBAND</b> is an adjustable gap between the operating ranges of output 1 and output 2 in which neither output operates (positive value) or both outputs operate (negative value). It is the difference between the nominal trip points of relay 1 and relay 2.
	-5.0 to 25.0 % 0 to 25.0 % 0.5 to 5.0 %	Time Duplex On-Off Duplex Position Proportional
<p>*The Local Setpoint will automatically adjust itself to be within the setpoint limit range. For example, if SP = 1500 and the SP HILIM is changed to 1200, the new Local Setpoint will be 1200.</p> <p>** Applies for Input 3 and Input 4 for recorders with two controllers.</p>		

Lower Display Prompt	Upper Display Range of Setting or Selection	Parameter Definition
<b>OUT HYST</b>	0.0 to 5.0 % of PV span	<b>HYSTERESIS (OUTPUT RELAY ONLY)</b> is an adjustable overlap of the ON/OFF states of each control output. This is the difference between the value of the process variable at which the control outputs energize and the value at which they de-energize. Only applicable for ON-OFF control.
<b>FAILSAFE</b>	0 to 100 %	<b>FAILSAFE OUTPUT VALUE</b> — the output level used when you have communications SHED or when NO BURNOUT is configured and input 1 fails.
	100PCT 0PCT	<b>For 3 Position Step Control</b> <b>100PCT</b> — motor position set to 100 % output position <b>0PCT</b> — motor position set to 0 % output position
<b>REM SW REM SW2</b>		<b>REMOTE SWITCHING (DIGITAL INPUT)</b> — contact closure enables one of the following:
	NONE	<b>NO DIGITAL INPUT SELECTION</b>
	TO MAN	<b>TO MANUAL</b> — contact closure selects Manual mode.
	TO LSP	<b>TO LOCAL SETPOINT</b> — contact closure selects the local setpoint.
	TO 2SP	<b>TO LOCAL SETPOINT 2</b> — contact closure selects local setpoint 2.
	TO DIR	<b>TO DIRECT ACTION</b> — contact closure selects Direct Control Action.
	RN/HLD	<b>RUN/HOLD</b> — contact closure suspends setpoint Ramp/Program. Contact open resumes.
	TUNE	<b>AUTOTUNE</b> — contact closure initiates Autotune.
	TIMER	<b>TIMER</b> — starts the timer, if enabled.  The Timer can also be started by the RH KEY or ALARM2. These parameters are found under the Timer set up group.
<b>MAN KEY</b>	ENABLE	<b>MANUAL MODE KEY SELECTION</b> — make selection to enable or disable the Manual Mode selection through the <b>MAN/AUTO</b> key.  <b>ENABLE</b> — allows you to use the <b>MAN/AUTO</b> key to select Manual Mode.
	DISABL	<b>DISABLE</b> — disables the <b>MAN/AUTO</b> key.
<b>PBorGAIN</b>		<b>PROPORTIONAL BAND UNITS</b> — select one of the following for the Proportional (P) term of the PID algorithm:

Lower Display Prompt	Upper Display Range of Setting or Selection	Parameter Definition
	PB PCT	<ul style="list-style-type: none"> <li>• <b>PROPORTIONAL BAND</b> — selects units of percent proportional band for the P term of the PID algorithm, where: <math display="block">PB \% = \frac{100 \% FS}{GAIN}</math></li> </ul>
	GAIN	<ul style="list-style-type: none"> <li>• <b>GAIN</b> selects the unitless term of gain for the P term of the PID algorithm, where: <math display="block">GAIN = \frac{100 \% FS}{PB \%}</math></li> </ul>
<b>MINorRPM</b>		<b>RESET UNITS</b> — selects units of minutes or repeat per minutes for the I term of the PID algorithm. 20 Repeats per Minute = 0.05 Minutes per Repeat.
	RPM	<b>REPEATS PER MINUTE</b> — the number of times per minute that the proportional action is repeated by reset.
	MIN	<b>MINUTES PER REPEAT</b> — the time between each repeat of the proportional action by reset.
<b>CONT1ALG</b>		<p>The <b>CONTROL ALGORITHM</b> lets you select the type of control that is best for your process.</p> <p><b>ATTENTION</b> If the recorder has two controllers (both enabled), CONT1ALG applies for controller #1 and CONT2ALG applies for controller #2.</p>
	ON-OFF	<p><b>ON/OFF</b> is the simplest control type. The output can be either ON (100 %) or OFF (0 %). The Process Variable (PV) is compared with the setpoint (SP) to determine the sign of the error (ERROR = PV-SP). The ON/OFF algorithm operates on the sign of the error signal.</p> <ul style="list-style-type: none"> <li>• In Direct Acting Control, when the error signal is positive, the output is 100 %; and when the error signal is negative, the output is 0 %. If the control action is reverse, the opposite is true. An adjustable overlap (Hysteresis Band) is provided between the on and off states.</li> <li>• Other prompts affected: “OUT HYST”</li> </ul> <p><b>DUPLEX ON/OFF</b> is an extension of this algorithm when the output is configured for Duplex. It allows the operation of a second ON/OFF output. There is a deadband between the operating ranges of the two inputs and an adjustable overlap (hysteresis) of the on and off states of each output. Both Deadband and Hysteresis are separately adjustable. With no relay action the controller will read 50 %.</p> <ul style="list-style-type: none"> <li>• Other prompts affected: “OUT HYST” and “DEADBAND”</li> </ul>



Lower Display Prompt	Upper Display Range of Setting or Selection	Parameter Definition
<b>CONT1ALG</b> (continued)	PID A  NOTE: PID A should not be used for Proportional only action (that is, no integral (reset) action.) Instead, use PD+MR with rate set to 0.	<p><b>PID A</b> is normally used for three-mode control. This means that the output can be adjusted somewhere between 100 % and 0 %. It applies all three control actions — Proportional (P), Integral (I), and Derivative (D) — to the error signal.</p> <p><i>Proportional (Gain)</i> — regulates the controller's output in proportion to the error signal (the difference between Process Variable and Setpoint).</p> <p><i>Integral (Reset)</i> — regulates the controller's output to the size of the error and the time the error has existed. (The amount of corrective action depends on the value of proportional Gain.)</p> <p><i>Derivative (Rate)</i> — regulates the controller's output in proportion to the rate of change of the error. (The amount of corrective action depends on the value of proportional Gain.)</p>
	PID B	<p><b>PID B</b> unlike the PID-A equation, the controller gives only an integral response to a setpoint change, with no effect on the output due to the gain or rate action, and it gives full response to PV changes. Otherwise controller action is as described for the PID-A equation. See note on PID-A.</p>
	PD+MR	<p><b>PD WITH MANUAL RESET</b> is used whenever integral action is not wanted for automatic control. The equation is computed with no integral contribution. The MANUAL RESET, which is operator adjustable, is then added to the present output to form the controller output. Switching between manual and automatic mode will not be bumpless.</p> <ul style="list-style-type: none"> <li>• If you select PD with Manual Reset you can also configure the following variations:               <ul style="list-style-type: none"> <li>– PD (Two Mode) control,</li> <li>– P (Single Mode) control.</li> </ul> </li> </ul> <p>Set Rate (D) and/or Reset Time (I) to 0.</p> <ul style="list-style-type: none"> <li>• Other prompts affected: "MAN RSET"</li> </ul>

Lower Display Prompt	Upper Display Range of Setting or Selection	Parameter Definition
<p><b>CONT1ALG</b> (continued)</p>	<p>3PSTEP</p>	<p>The <b>THREE POSITION STEP</b> algorithm allows the control of a valve (or other actuator), with an electric motor driven by two controller relay outputs; one to move the motor upscale, the other downscale without a feedback slidewire linked to the motor shaft. The deadband and hysteresis are adjustable in the same manner as the duplex output algorithm.</p> <p>The Three Position Step Control algorithm provides an output display (OUT) which is an estimated motor position since the motor is not using any feedback. Although this output indication is only an approximation, it is "corrected" each time the controller drives the motor to one of its stops (0 % or 100 %). It avoids all the control problems associated with the feedback slidewire (wear, dirt, noise). When operating in this algorithm, the estimated "OUT" display is shown to the nearest percent (i.e., no decimal).</p> <p>Refer to the Operation section for motor position displays.</p> <ul style="list-style-type: none"> <li>Other prompts affected: "DEADBAND" and Tuning prompts "GAIN", "RATE", "RESET".</li> </ul>
<p><b>OUT1ALG</b></p>		<p>The <b>OUTPUT ALGORITHM</b> lets you select the type of output you want. Not applicable with Control Algorithm prompt "3PSTEP."</p> <p><b>ATTENTION</b> If the recorder has two controllers (both enabled), OUT1ALG applies for controller #1 and OUT2ALG applies for controller #2. <i>Selections are model dependent. For example, current output models cannot be configured for Time Proportioning Simplex Output.</i></p>
	<p>TIME</p>	<p><b>RELAY SIMPLEX</b> — type of output using one SPDT relay. Its normally open (NO) or normally closed (NC) contacts are selected by positioning an internal jumper.</p> <ul style="list-style-type: none"> <li>Other prompts affected: "OUT HYST"</li> <li>Controller #1 uses Relay 3 and overrides control of relay by Alarm 3. Controller #2 uses Relay 5 and overrides control of relay by Alarm 5.</li> </ul>
	<p>CURRNT</p>	<p><b>CURRENT SIMPLEX</b> — type of output using one 4 to 20 mA signal that can be fed into a positive or negative grounded load of 0 to 1000 ohms. The signal can be recalibrated for any desired range from 3.25 mA to 21 mA for 0 % to 100 % output.</p>

Lower Display Prompt	Upper Display Range of Setting or Selection	Parameter Definition
<b>OUT1ALG</b> (continued)	POSITN	<p><b>POSITION PROPORTIONAL SIMPLEX</b> — type of output using two SPDT relays and a motor which has a 100 to 1000 ohms feedback slidewire. (Automatically selected when CONT ALG = 3PSTEP)</p> <ul style="list-style-type: none"> <li>• Other prompt affected: "DEADBAND"</li> <li>• Controller #1 uses Relays 3 and 4 and overrides control of relays by Alarms 3 and 4. Controller #2 uses Relays 5 and 6 and overrides control of relays by Alarms 5 and 6.</li> </ul>
	TIME D	<p><b>RELAY DUPLEX</b> — type of output using two SPDT relays. Its normally open (NO) or normally closed (NC) contacts are selected by positioning an internal jumper (see Installation section).</p> <ul style="list-style-type: none"> <li>• Other prompts affected: "DEADBAND"</li> <li>• Controller #1 uses Relays 3 and 4 and overrides control of relays by Alarms 3 and 4. Controller #2 uses Relays 5 and 6 and overrides control of relays by Alarms 5 and 6.</li> </ul>
	CUR TI	<p><b>CURRENT/RELAY DUPLEX (RELAY = HEAT)</b> is a variation of duplex with current active for 0 % to 50 % output (tuning set 2) and relay active for 50 % to 100 % output (tuning set 1).</p> <ul style="list-style-type: none"> <li>• Other prompts affected: "4-20 RNG," "DEADBAND"</li> <li>• Controller #1 uses Relay 3 and overrides control of relay by Alarm 3. Controller #2 uses Relay 5 and overrides control of relay by Alarm 5.</li> </ul>
	TI CUR	<p><b>RELAY/CURRENT DUPLEX (RELAY = COOL)</b> is similar to "CUR-TI" except that current is active for 50 % to 100 % and relay is active for 0 % to 50 %.</p> <ul style="list-style-type: none"> <li>• Other prompts affected: "4-20 RNG," "DEADBAND"</li> <li>• Controller #1 uses Relay 4 and overrides control of relay by Alarm 4. Controller #2 uses Relay 6 and overrides control of relay by Alarm 6.</li> </ul>

Lower Display Prompt	Upper Display Range of Setting or Selection	Parameter Definition
4-20 RNG		<b>CURRENT DUPLEX RANGE ALGORITHM</b> — used with Output Algorithm selections "CUR-TI" or "TI-CUR."
	50 PCT	<b>CURRENT DUPLEX RANGE (SPLIT)</b> enables the normal control current output to provide its full range for 50 % output change. <ul style="list-style-type: none"> <li>• If "CUR-TI" duplex was selected, the current output provides cool control.</li> </ul>
	100PCT	<b>CURRENT DUPLEX RANGE (FULL)</b> enables the normal control current output to provide duplex heat control over 0-100 % output change and the relay output to provide cool control.

***Repeat this procedure for Control 2 configuration.***

## 4.9 Tuning Parameters Set Up Group

### Introduction

Tuning consists of establishing the appropriate values for the tuning constants you are using so that your recorder responds correctly to changes in process variable and setpoint. You can start with predetermined values but you will have to watch the system to see how to modify them. There are two Tuning groups available.

### Tuning group prompts

Table 4-8 lists all the function prompts in the Tuning 1 and Tuning 2 setup group and their definitions.

**Table 4-8 Tuning Group Prompt Definitions**

Lower Display Prompt	Upper Display Range of Setting or Selection	Parameter Definition
<b>FUZZY</b>	DISABL ENABLE	<b>FUZZY OVERSHOOT SUPPRESSION FEATURE</b> DISABLE - Disables fuzzy overshoot suppression ENABLE - The recorder will use fuzzy logic to suppress or minimize any overshoot that may occur as a result of the existing tuning parameters. It does NOT change the parameters.
<b>ACCUTUNE</b>	DISABL ENABLE	<b>ACCUTUNE II</b> - On demand tuning algorithm DISABLE - Disables ACCUTUNE II ENABLE - TuneOF will be displayed as a status message. Use the Increment or Decrement key to toggle status to TuneON. New PID parameters will be entered automatically when tuning is complete.
<b>AT ERR</b>	NONE IDFL ABRT RUN	ACCUTUNE ERROR CODES (Read Only)

Lower Display Prompt	Upper Display Range of Setting or Selection	Parameter Definition
<p><b>PROP BD</b> or <b>GAIN</b></p>	<p>0.1 to 1000 % or 0.1 to 1000</p>	<p><b>PROPORTIONAL BAND</b> is the percent of the range of the measured variable for which a proportional recorder will produce a 100 % change in its output.</p> <p><b>GAIN</b> is the ratio of output change (%) over the measured variable change (%) that caused it.</p> $G = \frac{100\%}{PB\%}$ <p>where PB is the proportional band (in %)</p> <ul style="list-style-type: none"> <li>• If the PB is 20 %, then the Gain is 5. Likewise, a 3 % change in the error signal (SP-PV) will result in a 15 % change in the recorder's output due to proportional action. If the gain is 2, then the PB is 50 %.</li> <li>• Used with control algorithm PID-A or PID-B. Defined as "HEAT" Gain on Duplex models for variations of Heat/Cool applications.</li> <li>• The selection of Proportional Band or Gain is made in the control parameter group under prompt "PBorGAIN."</li> </ul>
<p><b>RATE MIN</b></p>	<p>0.08 to 10.00 minutes 0.08 or less = OFF</p>	<p><b>RATE</b> action affects the recorder's output whenever the deviation is changing; and affects it more when the deviation is changing faster.</p> <ul style="list-style-type: none"> <li>• Used with control algorithm PID-A or PID-B. Defined as "HEAT" Rate on Duplex models for variations of Heat/Cool applications.</li> </ul>
<p><b>RSET MIN</b> or <b>RSET RPM</b></p>	<p>0.02 to 50.00</p>	<p><b>RSET MIN</b> = RESET IN MINUTES / REPEAT <b>RSET RPM</b> = RESET IN REPEATS / MINUTE</p> <p><b>RESET</b> adjusts the recorder's output in accordance with both the size of the deviation (SP-PV) and the time it lasts. The amount of the corrective action depends on the value of Gain. The Reset adjustment is measured as how many times proportional action is repeated/minute.</p> <ul style="list-style-type: none"> <li>• Used with control algorithm PID-A or PID-B. Defined as "HEAT" Reset on Duplex models for variations of Heat/Cool applications.</li> <li>• The selection of minutes per repeat or repeats per minute is made in the control parameters group under prompt "MINorRPM."</li> </ul>
<p><b>MAN RSET</b></p>	<p>-100 to +100 (in % output)</p>	<p><b>MANUAL RESET</b> is only applicable if you have control algorithm PD WITH MANUAL RESET. Because a proportional recorder will not necessarily line out at setpoint, there will be a deviation (offset) from setpoint. This eliminates the offset and lets the PV line out at setpoint.</p>

Lower Display Prompt	Upper Display Range of Setting or Selection	Parameter Definition
<b>PROP BD2</b> or <b>GAIN 2</b>	0.1 to 1000 % or 0.1 to 1000	<b>PROPORTIONAL BAND 2</b> or <b>GAIN 2</b> , <b>RATE 2</b> , and <b>RESET 2</b> parameters are the same as previously described for "Heat" except that they refer to the <b>cool</b> zone tuning constants on duplex models or the second set of PID constants, whichever is pertinent.
<b>RATE2MIN</b>	0.08 to 10.00 minutes 0.08 or less = OFF	
<b>RSET2MIN</b> <b>RSET2RPM</b>	0.02 to 50.00	
<b>CYC SEC</b>	1 to 120 seconds	<b>CYCLE TIME (HEAT)</b> determines the length of one time proportional output relay cycle. Defined as "HEAT" cycle time for Heat/Cool applications.  • Electromechanical relays
<b>CYC2 SEC</b>	1 to 120 seconds	<b>CYCLE TIME 2 (COOL)</b> is the same as above except it applies to Duplex models as the cycle time in the "COOL" zone of Heat/Cool applications or for 2nd set of PID constants.  • Electromechanical relays

## 4.10 Setpoint Ramp Set Up Group

### Introduction

The Setpoint Ramp 1 and 2 Set Up groups contain the Function parameters that enable you to configure 2 setpoints. Each setpoint (SP RAMP 1 and SP RAMP 2) can be configured only one of three ways: ramp, rate, or setpoint program.

### Single Setpoint Ramp

Setpoint will ramp between the current local setpoint and a final setpoint over a time interval of up to 255 minutes. (SP RAMP).

### Setpoint Rate

The Setpoint Ramp Set Up group also contains the function parameters that let you configure a specific rate of change for any local setpoint change (SP RATE). It includes selections for Rate Up and Rate Down.

### Setpoint Program

Also included under this group are prompts for configuring a 36-segment Setpoint program (SP PROG). The prompts and instructions for Setpoint programming are presented in the *Section 6 - Setpoint Ramp/Soak Programming and Operation*.

- You can start and stop the ramp/program using the **RUN/HOLD** key.

### Setpoint Ramp/ Program group prompts

Table 4-9 lists all the function prompts in the Setpoint Ramp 1 or 2 setup group and their definitions. When you enable the ramp type (SP RAMP, SP RATE, SP PROG) the other two types are hidden from the display.

**Table 4-9 Setpoint Ramp 1 or 2 Group Definitions**

Lower Display Prompt	Upper Display Range of Setting or Selection	Parameter Definition
SP RAMP	ENABLE	<b>SINGLE SETPOINT RAMP</b> — Make selection to enable or disable the setpoint ramp function. Make sure you configure a ramp time and a final setpoint value. “SP PROG” and “SP RATE” must be disabled.
	DISABL	<b>ENABLE SETPOINT RAMP</b> — Allows you to start the setpoint ramp (in automatic mode). <b>DISABLE SETPOINT RAMP</b> — Disables the setpoint ramp.

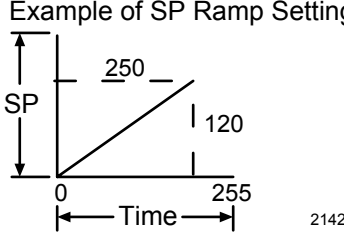

Lower Display Prompt	Upper Display Range of Setting or Selection	Parameter Definition
<b>TIME MIN</b>	0 to 255 minutes	<p><b>SETPOINT RAMP TIME</b> — Enter the number of minutes desired to reach the final setpoint.</p> <p>A ramp time of “0” implies an immediate change of setpoint.</p> <p>Example of SP Ramp Settings:</p> 
<b>FINAL SP</b>	Within SP limits	<p><b>SETPOINT RAMP FINAL SETPOINT</b> — Enter the value desired for the final setpoint. The recorder will operate at the setpoint set here when ramp is ended.</p>
<b>SP RATE (option)</b>	<p>ENABLE</p> <p>DISABL</p>	<p><b>SETPOINT RATE</b>—Lets you configure a specific rate of change for any local setpoint change. “SP RAMP” and “SP PROG” must be disabled.</p> <p><b>ENABLE SETPOINT RATE</b>—Allows the SP rate feature.</p> <p><b>DISABLE SETPOINT RATE</b>—Disables the setpoint rate.</p>
<b>EU/HR UP</b>	0 to 9999 in Engineering Units per hour	<b>RATE UP</b> —Value for SP Rate selection.
<b>EU/HR DN</b>	0 to 9999 in Engineering Units per hour	<b>RATE DOWN</b> —Value for SP Rate selection.
<b>SP PROG (option)</b>	<p>ENABLE</p> <p>DISABL</p>	<p><b>SETPOINT RAMP/SOAK PROGRAM</b> Available only with recorders that contain this option. “SP RAMP” and “SP RATE” must be disabled.</p> <p>For reasons of convenience, the prompts used when SP PROG is enabled are included in <i>Section 6 — Setpoint Ramp/Soak Programming and Operation</i>.</p>

## 4.11 Timer Set Up Group



### Introduction

The Timer gives a countdown or elapsed time, after which Relay 1 energizes. If Timer is enabled, it has exclusive control over Relay 1; that is, Alarm 1 will not control the relay.

### Timer group prompts

Table 4-10 lists all the function prompts in the Timer setup group and their definitions.

**Table 4-10 Timer Group Definitions**

Lower Display Prompt	Upper Display Range of Setting or Selection	Parameter Definition
<b>TIMER</b>	ENABLE DISABL	Enables or disables the timer option
<b>PERIOD</b>	0:00 to 99:59	Configures the length of the timeout period (from 0 to 99 hours, 59 minutes).
<b>START</b>	RH KEY ALARM 2 TIME	Timer starts with the keyboard (Run/Hold key). Timer starts with Alarm 2. Wake time parameter—Starts timer when the value configured for the Wake Time Event is reached. (See WAKE MIN, WAKE HR, WAKE DAY, WAKE MON in the Time Set Up group.)  The Timer can also be started by a discrete input, REM SW or REM SW2. These prompts are found under the Control Set Up Group.
<b>LDISPLAY</b>	TREM  ET	Select whether time remaining (TREM) or elapsed time (ET) is displayed for the timer option. The time is shown on the lower display in hh:mm format along with a rotating “clock” character.  Time remaining: If the “clock” rotation is clockwise, elapsed time is indicated.  □.□□  Elased time: If the “clock” rotation is counterclockwise, time left is indicated.  □.□□
<b>RESET</b>	RH KEY ALARM 1 REPEAT	Timer resets with the keyboard (Run/Hold key). Timer resets with Alarm 1. In Repeat Mode, the timer restarts immediately upon timeout and activates the relay for 1 to 5 seconds.
<b>ON-TIME</b>	1 SEC 2 SEC 3 SEC 4 SEC 5 SEC	Relay 1 on-time when timer is in repeat mode.
<b>INCRMENT</b>	MINUTE SECOND	Select the units of the timer.

## 4.12 Alarms Set Up Group

### Introduction

An alarm is an indication that an event that you have configured (for example—Process Variable) has exceeded one or more alarm limits. There are six alarms available, each with two setpoints. You can configure each of these two setpoints to alarm on various controller parameters. There are two alarm output selections, high and low. You can configure each setpoint to alarm either high or low. These are called single alarms. You can also configure the two setpoints to alarm on the same event and to alarm both high and low. An adjustable hysteresis of 0.0 % to 100.0 % is configurable for each alarm setpoint.

### Priority of functions that operate relays

During alarm conditions an alarm will deenergize its associated relay unless a higher priority function has been configured for that relay. See Table 4-11. If you want the alarm to control the relay, do not configure a higher priority function.

**Table 4-11 Priority of functions that operate relays**

Relay	Relay is controlled by (in order of priority)
1	1. Timer function 2. Alarm 1
2	Alarm 2 only
3	1. Controller 1 output algorithms Relay Simplex, Position Proportional, Relay Duplex, Current/Relay Duplex 2. Alarm 3
4	1. Controller 1 output algorithms Position Proportional, Relay Duplex, Current/Relay Duplex 2. Alarm 4
5	1. Controller 2 output algorithms Relay Simplex, Position Proportional, Relay Duplex, Current/Relay Duplex 2. Alarm 5
6	1. Controller 2 output algorithms Position Proportional, Relay Duplex, Current/Relay Duplex 2. Alarm 6

### Alarms group prompts

Table 4-12 lists all the function prompts in the Alarms setup group and their definitions. These prompts repeat for all 6 alarms.



**TIP**

To configure an alarm for a setpoint program segment event, program either type (AxS1TYPE or AxS2TYPE) as EVENT. It is not necessary to configure any other alarm prompts.

**Table 4-12 Alarms Group Definitions**

Lower Display Prompt	Upper Display Range of Setting or Selection	Parameter Definition
<b>AxS1 VAL</b>	Value in engineering units	<b>ALARM x SETPOINT 1 VALUE</b> — this is the value at which you want the alarm type chosen in prompt "AxS1TYPE" to actuate. The value depends on what the setpoint has been configured to represent. NO setpoint is required for Communications SHED. For SP Programming the value is the segment number for which the event applies.
<b>AxS2 VAL</b>	Value in engineering units	<b>ALARM x SETPOINT 2 VALUE</b> — this is the value at which you want the alarm type chosen in prompt "AxS2TYPE" to actuate.  • The details are the same as "AxS1 VAL".
<b>AxS1TYPE</b>	NONE IN 1 IN 2 IN 3 IN 4 RH DEV (loop 1) OUT (loop 1) DEV2 (loop 2) OUT2 (loop 2) EVENT TOTAL 1 TOTAL 2 TOTAL 3 TOTAL 4	<b>ALARM x SETPOINT 1 TYPE</b> — select what you want Setpoint 1 of Alarm 1 to represent. It can represent any of the Inputs, Relative Humidity, Deviation (loop 1 or 2), Output (loop 1 or 2), and if you have a model with communications, you can configure the recorder to alarm on SHED. If you have setpoint programming, you can alarm when a segment goes ON or OFF (loop 1 or 2).  An alarm can also be set to activate if a totalizer value has exceeded a configured alarm value.  <b>NO ALARM</b> <b>INPUT 1</b> <b>INPUT 2</b> <b>INPUT 3</b> <b>INPUT 4</b> <b>RELATIVE HUMIDITY</b> <b>LOOP 1 DEVIATION</b> <b>LOOP 1 OUTPUT</b> <b>LOOP 2 DEVIATION</b> <b>LOOP 2 OUTPUT</b> <b>EVENT ON (SP PROGRAMMING)</b> <b>TOTALIZER TO ALARM ON</b> <b>TOTALIZER TO ALARM ON</b> <b>TOTALIZER TO ALARM ON - MODEL DR45AW ONLY</b> <b>TOTALIZER TO ALARM ON - MODEL DR45AW ONLY</b>

Lower Display Prompt	Upper Display Range of Setting or Selection	Parameter Definition
<b>AxS2TYPE</b>	Same as AxS1TYPE	<b>ALARM x SETPOINT 2 TYPE</b> — select what you want Setpoint 2 of Alarm x to represent. The selections are the same as AxS1TYPE.
<b>AxS1 H L</b>	HI LO	<b>ALARM x SETPOINT 1 STATE</b> — select whether you want the alarm type chosen in prompt "AxS1TYPE" to alarm high or low or the beginning or end of a segment in setpoint Ramp/Soak programming.  <b>HI ALARM</b> – Relay coil is de-energized when the PV is <b>above</b> the setpoint. <b>LO ALARM</b> – Relay coil is de-energized when the PV is <b>below</b> the setpoint.
<b>AxS1SCAL</b>	1 10 100 1000 10000 100000 1E6	<b>MULTIPLIER FOR ALARM TYPE "TOTAL" SELECTION</b> — the alarm is only a high value. Enter a scaler of from 1 to 1000000.  (Base value x multiplier = alarm setpoint value)
<b>AxS2 H L</b>	HI LO	<b>ALARM x SETPOINT 2 STATE</b> — select whether you want the alarm type chosen in prompt "AxS2TYPE" to alarm high or low or the beginning or end of a segment in setpoint Ramp/Soak programming.  <b>HI ALARM</b> <b>LO ALARM</b>
<b>AxS2SCAL</b>	1 10 100 1000 10000 100000 1E6	<b>MULTIPLIER FOR ALARM TYPE "TOTAL" SELECTION</b> — the alarm is only a high value. Enter a scaler of from 1 to 1000000.  (Base value x multiplier = alarm setpoint value)
<b>ALx HYST</b>	0.0 to 100.0 % of span or full output as appropriate	<b>ALARM HYSTERESIS</b> — an adjustable hysteresis is provided on each alarm such that when the alarm is OFF it activates at exactly the alarm setpoint; when the alarm is ON, it will not deactivate until the variable is 0.0 % to 100.0 % (whatever has been set) away from the alarm setpoint.  <ul style="list-style-type: none"> <li>• Configure the hysteresis of the alarms based on INPUT signals as a % of input range span.</li> <li>• Configure the hysteresis of the alarm based on OUTPUT signals as a % of the full scale output range.</li> </ul>

*Repeat this procedure for Alarm 2, Alarm 3, Alarm 4, Alarm 5, Alarm 6 configuration.*

## 4.13 Auxiliary Output Set Up Group

### Introduction

This provides a milliampere output representing any of twelve control parameters: Input 1-4, PV 1-2, Deviation 1-2, Output 1-2, Setpoint 1-2. The display for auxiliary Output viewing will be in engineering units for all but output. Output will be designated in percent (%).

### Timer group prompts

Table 4-13 lists all the function prompts in the Auxiliary Output setup group and their definitions.

**Table 4-13 Auxiliary Output Group Definitions**

Lower Display Prompt	Upper Display Range of Setting or Selection	Parameter Definition
<b>AUX OUT</b>		<p><b>AUXILIARY OUTPUT SELECTION</b> provides an mA output representing any of twelve control parameters. The display for Auxiliary Output viewing will be in engineering units for all but output. Output will be designated in percent (%).</p> <ul style="list-style-type: none"> <li>Other prompts affected by these selections: "4 mA VAL" and "20mA VAL".</li> </ul>
	DISABL	<b>NO AUXILIARY OUTPUT</b>
	IN 1	<p><b>INPUT 1</b>—This represents the configured range of input 1. FOR EXAMPLE:            Type "J" Thermocouple (0 to 1600 °F)            0 °F display = 0 % output            1600 °F display = 100 % output</p>
	IN 2	<b>INPUT 2</b> represents the value of the configured range of input 2.
	PV 1	<b>PROCESS VARIABLE 1</b> —Represents the value of the Process Variable for Loop 1. PV = Input 1 + Bias
	DEV 1	<p><b>DEVIATION 1 (PROCESS VARIABLE MINUS SETPOINT)</b>—Represents –100 % to +100 % of the selected PV span in engineering units for Loop 1. FOR EXAMPLE:            Type "T" Thermocouple            PV range = –300 °F to +700 °F            PV span = 1000 °F            Deviation range = –1000 °F to +1000 °F            If PV = 500 °F            and SP = 650 °F            then Deviation Display = –150 °F            Auxiliary Output = 42.5 %</p> <p>NOTE: A deviation of 0 °F yields an auxiliary output of 50 %.</p>
	OUT 1	<b>OUTPUT 1</b> —Represents the displayed controller output in percent (%) for Loop 1.

Lower Display Prompt	Upper Display Range of Setting or Selection	Parameter Definition
<b>AUX OUT (continued)</b>	SP 1	<b>SETPOINT 1</b> —Represents the value of the setpoint in units of PV for Loop 1.
	PV 2	<b>PROCESS VARIABLE 2</b> —Represents the value of the process variable for Loop 2.
	DEV 2	<b>DEVIATION 2 (PROCESS VARIABLE MINUS SETPOINT)</b> —Represents –100 % to +100 % of the selected PV span for Loop 2.  See Example at DEV 1.
	OUT 2	<b>OUTPUT 2</b> —Represents the displayed controller output in percent (%) for Loop 2.
	SP 2	<b>SETPOINT 2</b> —Represents the value of the setpoint in units of PV for Loop 2.
	IN 3	<b>INPUT 3</b> —Represents the value of the configured range of Input 3.
	IN 4	<b>INPUT 4</b> —Represents the value of the configured range of Input 4.
	<b>4 mA VAL</b>	Low Scale Value within the range of the selected variable to represent 4 mA
<b>20mA VAL</b>	High Scale Value within the range of the selected variable to represent 20 mA	<b>AUXILIARY OUTPUT HIGH SCALING FACTOR</b> —Use a value in engineering units for: Input 1, Input 2, Process Variable, Deviation,* and Setpoint.  Use a value in percent (%) for Output. (Output can be between –5 % and +105 %.)  *When Deviation is selected, only one operating parameter will be entered. This value represents the deviation level that will produce 20 mA output. Zero deviation will produce a center scale (12 mA) output. A negative deviation equal in magnitude to the Auxiliary Output High Value will produce a low end (4 mA) output.

*Repeat for AUX OUT 2 and AUX OUT 3.*

## 4.14 Modbus Communications Set Up Group

### Introduction

This option allows the DR4500A to be connected to a host computer via the Modbus protocol. Up to 99 addresses and a maximum of 15 units can be configured over this link.



### REFERENCE

Refer to Documents 51-52-25-66 and 51-52-25-69 for a complete description of the RS485 Modbus Communications Option.

### Communications group prompts

Table 4-14 lists all the function prompts in the Modbus Communications set up group and their functions.

**Table 4-14 Modbus Communications Group Definitions**

Lower Display Prompt	Upper Display Range of Setting or Selection	Parameter Definition
<b>ComSTATE</b>	DISABL MODBUS	<b>DISABL</b> —Disables the communications option. <b>MODBUS</b> —Allows Modbus communication prompts.
<b>Com ADDR</b>	1 to 99	<b>COMMUNICATIONS STATION ADDRESS</b> — This is a number that is assigned to the recorder that is to be used with the communications option.
<b>BAUD</b>	300 600 1200 2400 4800 9600 19200 38400	<b>BAUD RATE</b> is the transmission speed in bits per second.  <b>300 Baud</b> <b>600 Baud</b> <b>1200 Baud</b> <b>2400 Baud</b> <b>4800 Baud</b> <b>9600 Baud</b> <b>19200 Baud</b> <b>38400 Baud</b>
<b>XMT DLAY</b>	NONE 10MSEC 20MSEC 30MSEC 40MSEC 50MSEC	<b>TRANSMIT DELAY</b> —This is the approximate time delay between receipt of Modbus request message and start of response message (in addition to message processing time).
<b>DBL BYTE</b>	FP B FP BB FP L FP LB	<b>DOUBLE REGISTER BYTE ORDER</b> —The transmitted or received order of the 4 bytes comprising an IEEE floating point value. The default order is EXP, MH, MM, ML, or 0123 for reference.  <b>0123</b> (Big Endian) <b>1032</b> (Big Endian, Byte Swapped) <b>3210</b> (Little Endian) <b>2301</b> (Little Endian, Byte Swapped)



## 4.15 Options Set Up Group

### Introduction

The Options Set Up Group lets you enable or disable some of the options that are available on the DR4500. You can select the power frequency, select relative humidity as a measurement and a atmospheric pressure compensation, select deviation recording action, and set the desired deviation setpoint.

### Options group prompts

Table 4-15 lists all the function prompts in the Option set up group and their functions.

**Table 4-15 Option Group Definitions**

Lower Display Prompt	Upper Display Range of Setting or Selection	Parameter Definition
<b>REJ FREQ</b>	60HZ 50HZ	<b>REJECTION FREQUENCY</b> – be sure that this selection agrees with the line voltage frequency.
<b>HF REJ</b>	ENABLE DISABL	<b>HIGH FREQUENCY REJECTION</b> – This selection allows high frequency noise rejection. It is used to quiet noisy pens or PV.  <b>ATTENTION</b> For fast processes it will cause additional lag.
<b>RELHUMID</b>	NO YES	<b>RELATIVE HUMIDITY</b> – allows you to activate or deactivate the RH calculation algorithm.  <ul style="list-style-type: none"> <li>You must select 100RH input type for two inputs to measure RH. It requires two 100-ohm RTD inputs so INPUT 2 must be enabled for this prompt to appear.</li> <li>Also, you must select RH for “PEN2IN” which represents the “wet bulb” temperature when input 2 is selected.</li> </ul>
<b>ATMPRES</b>	590 to 800 mmHg	<b>ATMOSPHERIC PRESSURE COMPENSATION</b> – This prompt only appears if you select “YES” at “RELHUMID” prompt previously. Select the desired compensation.
<b>DEVIATION</b>	NONE SETPNT CHAN1	<b>DEVIATION</b> – selects deviation recording action.  <ul style="list-style-type: none"> <li>NONE – No deviation recording</li> <li>SETPNT – Records deviation from setpoint</li> <li>CHAN1 – Pen 1 records the difference between Input 1 and Input 2.</li> </ul>
<b>DEVSETPT</b>	–999.0 to 9999	<b>DEVIATION SETPOINT VALUE</b> – sets the desired deviation setpoint value for deviation recording.  <ul style="list-style-type: none"> <li>This prompt only appears if “SETPNT” was selected at prompt “DEVIATION” previously.</li> </ul>

Lower Display Prompt	Upper Display Range of Setting or Selection	Parameter Definition
<b>SCROLL</b>		<b>LOWER DISPLAY SCROLL</b> —The lower display will automatically change to the next item (as if the <b>LOWR DISP</b> key had been pressed) at the interval selected.
	NONE	<b>NONE</b> —Disables the scroll function.
	1 SEC	<b>1 SEC</b> —One second intervals
	2 SEC	<b>2 SEC</b> —Two second intervals
	3 SEC	<b>3 SEC</b> —Three second intervals
<b>GRANDTOT</b>	ENABLE DISABL	<b>GRAND TOTALIZER</b> —When enabled it prints, on the chart, the sum of ALL the enabled totalizers as TOTAL = XXXXXXXXXXXX. This is printed in the space for totalizer 4. If grand total is disabled, total 4 on the DR45AW model will print normally.

## 4.16 Event Message Set Up Group

### Introduction

This Set Up group allows you to specify six event messages to be printed on a designated area of the chart and triggered by a specific selectable actuation. The message can be six characters long.

Press the **FUNC** key until the specific event prompt appears in the lower display.

### Event Message group prompts

Table 4-16 lists all the function prompts in the Event Message set up group and their definitions.

**Table 4-16 Event Message Group Definitions**

Lower Display Prompt	Upper Display Range of Setting or Selection	Parameter Definition
<b>EVENT n</b> (n = 1, 2, 3, 4, 5, or 6)	60HZ 50HZ	<b>EVENT TRIGGER</b> —Select the triggering source for each of the six event messages.
	NONE	<b>NONE</b> —No event message
	EXT SW1	<b>EXT SW1</b> —Event triggered by external switch 1 closure
	EXT SW2	<b>EXT SW2</b> —Event triggered by external switch 2 closure
	ALARM 1	<b>ALARM 1</b> —Event triggered by Alarm 1
	ALARM 2	<b>ALARM 2</b> —Event triggered by Alarm 2
	ALARM 3	<b>ALARM 3</b> —Event triggered by Alarm 3
	ALARM 4	<b>ALARM 4</b> —Event triggered by Alarm 4
	ALARM 5	<b>ALARM 5</b> —Event triggered by Alarm 5
<b>MESSAGE n</b> (n = 1, 2, 3, 4, 5, or 6)	0 to 9 A to Z + - / (blank)*	<b>MESSAGE FOR EVENT</b> —Select a message to be printed when Event is triggered. You can use up to six characters.  *For alphanumeric entries, the display will cycle, from left to right, with highlighting (increased brightness) of each digit. The value of each digit can be changed only when it is highlighted.
<b>POSITION n</b> (n = 1, 2, 3, 4, 5, or 6)	0 to 100 %	<b>CHART POSITION FOR MESSAGE</b> —Select where you want the message to appear on the chart.

*Repeat for all messages required.*

## 4.17 Lockout Parameters Set Up Group

### Introduction

These are the parameters that you will set to lockout any unauthorized changes to the recorder's configuration and calibration prompts. You must know the PASSWORD in order to change the Lockout configuration. Refer to *Appendix B* for more information on security lockout.



#### ATTENTION

Configuration can also be locked using S1 switch on the main printed circuit board. Refer to *Subsection 2.9 – Lockout Switch Configuration*.

This feature also includes the special screw and plate that provide for the lead seal capability for sealing the chart plate.

### Set this group last

Because this group contains functions that have to do with security and lockout, we recommend that you configure this group last, after all the other configuration data has been loaded.

### Lockout group prompts

Table 4-17 lists all the function prompts in the Lockout set up group and their definitions.

**Table 4-17 Lockout Group Definitions**

Lower Display Prompt	Upper Display Range of Setting or Selection	Parameter Definition
<b>PASSWORD</b>	Select up to four alphanumeric characters	<p><b>PASSWORD</b> -- this selection determines the password that will be required to gain access to the lockout prompt.</p> <ul style="list-style-type: none"> <li>• + + + + is the factory default password.</li> </ul>
<b>LOCKOUT</b>	<p>NONE</p> <p>CALIB</p> <p>+CONF</p> <p>MAX</p>	<p><b>LOCKOUT</b> applies to one of the functional groups: Configuration, Calibration, Tuning, Adaptive Tune. <b>DO NOT CONFIGURE UNTIL ALL CONFIGURATION IS COMPLETE.</b></p> <ul style="list-style-type: none"> <li>• If the correct password was entered, you can call up this prompt.</li> </ul> <p>No Lockout – all groups read/write.</p> <p><b>CALIB</b> – All are available for read/write except for the Calibration group.</p> <p><b>+CONF</b> – Tuning, SP Ramp and program groups are read/write. All other groups are read only. Calibration group is not available.</p> <p><b>MAX</b> – Calibration group not available. All other groups are Read-only.</p> <p><b>ATTENTION</b> Do not leave in "NONE" Lockout.</p>
<b>CHANGE</b>	<p>Selections are:</p> <p>0 to 9</p> <p>A to Z</p>	<p><b>CHANGE PASSWORD</b> – Changes default password to one of your own. Be sure to record the new password in a safe location.</p>

## 4.18 Printing Characteristics Adjustments

### Introduction

With software version 1005 (and newer), two different hot stylus pen designs are available; check your model number for:

Table III =      for high speed stylus 30756304-001 (black tip)

Table III =      for abrasion resistant jewel tip stylus 30756304-002  
(beige tip)

The abrasion resistant stylus is designed for recording applications that include highly abrasive environments. The abrasion resistant stylus should only be used with chart speeds from 24 hrs/rev to 31 days/rev.

### Configuration choices

Configuration choices are now provided for **PEN TYPE** and the selection made must match the stylus design.

- **PEN TYPE = NORMAL** is for the high speed stylus design.
- **PEN TYPE = JEWEL** is used **only** for abrasion resistant stylus design.



#### CAUTION

If the "JEWEL" selection is accidentally used with the high-speed design, the life of that stylus will be shortened.

---

### Printing characteristics adjustments

Normally there is no need to adjust the printing characteristics as part of an input or output calibration procedure. However, if the chart printing appears to be faded, you can use the procedure in Table 4-18 to make slight adjustments in the print contrast.



#### ATTENTION

To access Set-up group prompt "ADJUST", the Set Up group prompt "LOCKOUT" must be set to "NONE". If the group prompt "LOCKOUT" has been configured for "CALIB" or "MAX" selection, you will not be able to access the Printing Characteristics Group prompt. Refer to *Subsection 4.17* for details.

---

### Printing characteristics adjustments procedure

Table 4-18 is the procedure to adjust the printing characteristics of your recorder.

**Table 4-18 Printing Characteristics Adjustment Procedure**

Step	Description	Press	Action
1	Enter Set Up Group ADJUST	<b>SET UP</b>	Until you see: <i>Upper Display:</i> ADJUST <i>Lower Display:</i> {PRINTING}
2	Select Trace Line Contrast	<b>FUNC</b>	Until you see: <i>Upper Display:</i> DARK, MEDIUM, or LIGHT <i>Lower Display:</i> TRACE LN  <ul style="list-style-type: none"> <li>• Press ▲ or ▼ to select the desired contrast.</li> </ul>
3	Select Grid Line Contrast	<b>FUNC</b>	Until you see: <i>Upper Display:</i> DARK, MEDIUM, or LIGHT <i>Lower Display:</i> GRID LN  <ul style="list-style-type: none"> <li>• Press ▲ or ▼ to select the desired contrast..</li> </ul>
4	Select Stylus	<b>FUNC</b>	Until you see: <i>Upper Display:</i> NORMAL or JEWEL <i>Lower Display:</i> PEN TYPE  <ul style="list-style-type: none"> <li>• Press ▲ or ▼ to select the pen type.</li> <li>• Select "<b>NORMAL</b>" if high speed stylus (black tip) is installed.</li> <li>• Select "<b>JEWEL</b>" only if abrasion resistant stylus (beige tip) is installed.</li> </ul>
5	Return to normal operation	<b>LOWR DISP</b>	Return to normal operation and observe the change in printing characteristics.  <ul style="list-style-type: none"> <li>• Change Set Up group "LOCKOUT" to something other than "NONE".</li> </ul>

# 5. Operation

## 5.1 Overview

### Introduction

This section gives you all the information necessary to monitor and operate your recorder and for performing routine maintenance tasks. In this section assume that the recorder has been properly installed and configured, and that the inputs are properly calibrated.

Some of the procedures in this section are required only initially, and some are required only randomly, as conditions dictate. Once the recorder is up and running, required operation actions are infrequent and straightforward.

Review the Operator Interface, Display and Keypad descriptions shown in *Section 1 - Overview*.

### What's in this section?

This section contains the following topics:

	Topic	See Page
5.1	Overview	137
5.2	Start-up	138
5.3	Monitoring Your Recorder	142
5.4	Operator Functions	148
5.5	Operating Modes	149
5.6	Setpoints	151
5.7	Single Setpoint Ramp	153
5.8	Using Two Sets of Tuning Constants (PID Values)	156
5.9	Using Accutune II	159
5.10	Alarm Setpoints	162
5.11	Three Position Step Control Algorithm	163
5.12	Digital Input Option (Remote Switching)	164
5.13	Resetting and Displaying Totalizer Value	165
5.14	Monitoring the External Event Operation	167
5.15	Maximizing Pen Life	168
5.16	Routine Maintenance	169
5.17	Installing/Replacing Chart	170
5.18	Chart Operation	171

## 5.2 Start-up

### Preparation

Before start-up, there are two tasks to perform:

- Install or replace the circular chart as described in 5.16 - *Routine Maintenance*.
- Be sure that the configured settings for the current time and wake time (time at which recording begins) are correct. Note that the recorder is “awake” during start-up to verify interaction with the process.

During start-up, you should verify the interaction between your process and the DR4500A recorder to be sure that your process can tolerate some upsets during this procedure.

### Diagnostic tests

When power is applied, the recorder will run four diagnostic tests. Table 5-1 lists the four diagnostic tests.

**Table 5-1 Power Up Diagnostic Tests**

Prompt on Lower Display	Condition
RAM TEST	Check RAM
CONFTEST (configuration checksum)	Check nonvolatile memory
CAL TEST (working calibration)	Check calibration
BATTERY	Check the battery

### Test failures

If control is enabled and one or more of these tests fail, the recorder will go to the Failsafe Manual Mode, and “FAILSAFE” will flash in the lower display.

If control is *not* configured, the self-test failures will be displayed periodically as other messages are presently displayed (CNFG ERR, CAL1 ERR, CAL2 ERR, or BATT LOW).

### Troubleshooting

Refer to “DEVICE STATUS” in *Section 9 - Troubleshooting/Service* to identify and correct the problem.



### Check the displays and keys

Use the procedure in Table 5-2 to run the display and key test.

**Table 5-2 Procedure for Testing the Displays and Keys**

Press	Result																		
<p><b>SET UP</b> and hold in, then press <b>FUNC</b> at the same time</p>	<p>The recorder runs a display test. All the displays will light for 8 seconds, then you will see:</p> <p><i>Upper Display: keys</i></p> <p><i>Lower Display: try all</i></p>																		
<p>Press each key to see if it works</p>	<p>When the key is pressed, the lower display indicates the name of the key pressed.</p> <table border="1" data-bbox="727 804 1300 1266"> <thead> <tr> <th data-bbox="727 804 1027 854">Key Pressed</th> <th data-bbox="1027 804 1300 854">Lower Display</th> </tr> </thead> <tbody> <tr> <td data-bbox="727 854 1027 905">SET UP</td> <td data-bbox="1027 854 1300 905">SET UP</td> </tr> <tr> <td data-bbox="727 905 1027 955">LOWR DISP</td> <td data-bbox="1027 905 1300 955">LWR DISP</td> </tr> <tr> <td data-bbox="727 955 1027 1005">MAN/AUTO</td> <td data-bbox="1027 955 1300 1005">AUTO MAN</td> </tr> <tr> <td data-bbox="727 1005 1027 1056">RESET</td> <td data-bbox="1027 1005 1300 1056">RESET</td> </tr> <tr> <td data-bbox="727 1056 1027 1106">CHART</td> <td data-bbox="1027 1056 1300 1106">CHART</td> </tr> <tr> <td data-bbox="727 1106 1027 1157">▲</td> <td data-bbox="1027 1106 1300 1157">INCRMENT</td> </tr> <tr> <td data-bbox="727 1157 1027 1207">▼</td> <td data-bbox="1027 1157 1300 1207">DECRMENT</td> </tr> <tr> <td data-bbox="727 1207 1027 1266">RUN/HOLD</td> <td data-bbox="1027 1207 1300 1266">RUN HOLD</td> </tr> </tbody> </table>	Key Pressed	Lower Display	SET UP	SET UP	LOWR DISP	LWR DISP	MAN/AUTO	AUTO MAN	RESET	RESET	CHART	CHART	▲	INCRMENT	▼	DECRMENT	RUN/HOLD	RUN HOLD
Key Pressed	Lower Display																		
SET UP	SET UP																		
LOWR DISP	LWR DISP																		
MAN/AUTO	AUTO MAN																		
RESET	RESET																		
CHART	CHART																		
▲	INCRMENT																		
▼	DECRMENT																		
RUN/HOLD	RUN HOLD																		

- If no key is pressed for 25 seconds, the test times out and the recorder exits the key test.
- If any test fails, go to *Subsection 9.3 Self Diagnostics* for more information.

### Key error

When a key is pressed and the prompt “KEY ERROR” appears in the lower display, it will be for one of the following reasons:

- parameter not available,
- not in Set Up mode, press **SET UP** key first,
- key malfunction, perform keyboard test.

### Start-up procedure

Use the procedure listed in Table 5-3 to start up the recorder.

Open the recorder door. Apply power and wait for the recorder to run its power-up tests.



**ATTENTION**

- If FAILSAFE starts blinking in the lower display, refer to *Section 9* for troubleshooting data.
- For recorders with two controllers (both enabled), be sure the CHN '1' indication is lit for steps 2-6. If CHN 1 is not lit, sequentially press the **LOWR DISP** key until "1" is lit when "OUT" is displayed.

**Table 5-3 Procedure for Starting Up the Recorder**

Step	Description	Press	Action
1	Pen check		For RECORDER ONLY models, just check that the pen is operating and skip to step 6.
2	Select manual mode	<b>MAN AUTO</b>	Until "MAN" indicator is ON. The recorder is in manual mode and the Output (OUT) in percent is displayed in the lower display.
3	Adjust the output	▲ or ▼	Adjust the output value and ensure that the final control element is functioning correctly.  <i>Upper Display:</i> shows the PV value  <i>Lower Display:</i> shows <b>OUT</b> and the output value in %  Make sure the pen trace on the chart corresponds to the change in output.
4	Tune the recorder	<b>SET UP</b>	Make sure the recorder has been configured properly and all the values and selections have been recorded on the Configuration Record Sheet.  To tune your recorder automatically, see <i>Subsection 5.9 Using Accutune II</i> .  Refer to Set Up group TUNING 1 or TUNING 2 to ensure that the proper selections for PROP BD or GAIN, RATE MIN, and RSET MIN or RSET RPM have been entered.
5	Enter the local setpoint	<b>LOWR DISP</b>	Until you see:  <i>Upper Display:</i> shows the PV value  <i>Lower Display:</i> <b>SP</b> and the local setpoint value
		▲ or ▼	Adjust the local setpoint to the value at which you want the process variable maintained.  The local setpoint cannot be changed if the Setpoint Ramp function is enabled.  "H" or "R" appears in the upper display.

Step	Description	Press	Action
6	Select automatic mode	<b>MAN AUTO</b>	<p>Until "A" indicator is ON. The recorder is in Automatic mode.</p> <p>The recorder will automatically adjust the output to maintain the process variable at setpoint as tracked by the pen trace, if the recorder is properly tuned.</p>
7	Start up Controller #2	<b>LOWR DISP</b>	<p>Until "2" is lit when "OUT" is displayed.</p> <p>For recorders with two controllers (both enabled), repeat steps 2-6 for controller #2, but be sure CHN "2" indicator is lit instead of CHN "1".</p>
8	Exit Start-up		Close the door and monitor the operation.

## 5.3 Monitoring Your Recorder

### Introduction

Besides the historical chart record, you can monitor the recorder's indicators and displays to get an instantaneous view of various process conditions and of the control loop status.

Diagnostic error messages signal detection of malfunctions in certain internally monitored data. Alarm and tuning messages indicate alarms in effect and control loops being tuned.

### Operator interface

The indicators and displays on the operator interface let you see what is happening to your process and how the recorder is responding.

Figure 5-1 is a view of the operator interface. A description of the displays and indicators is included.

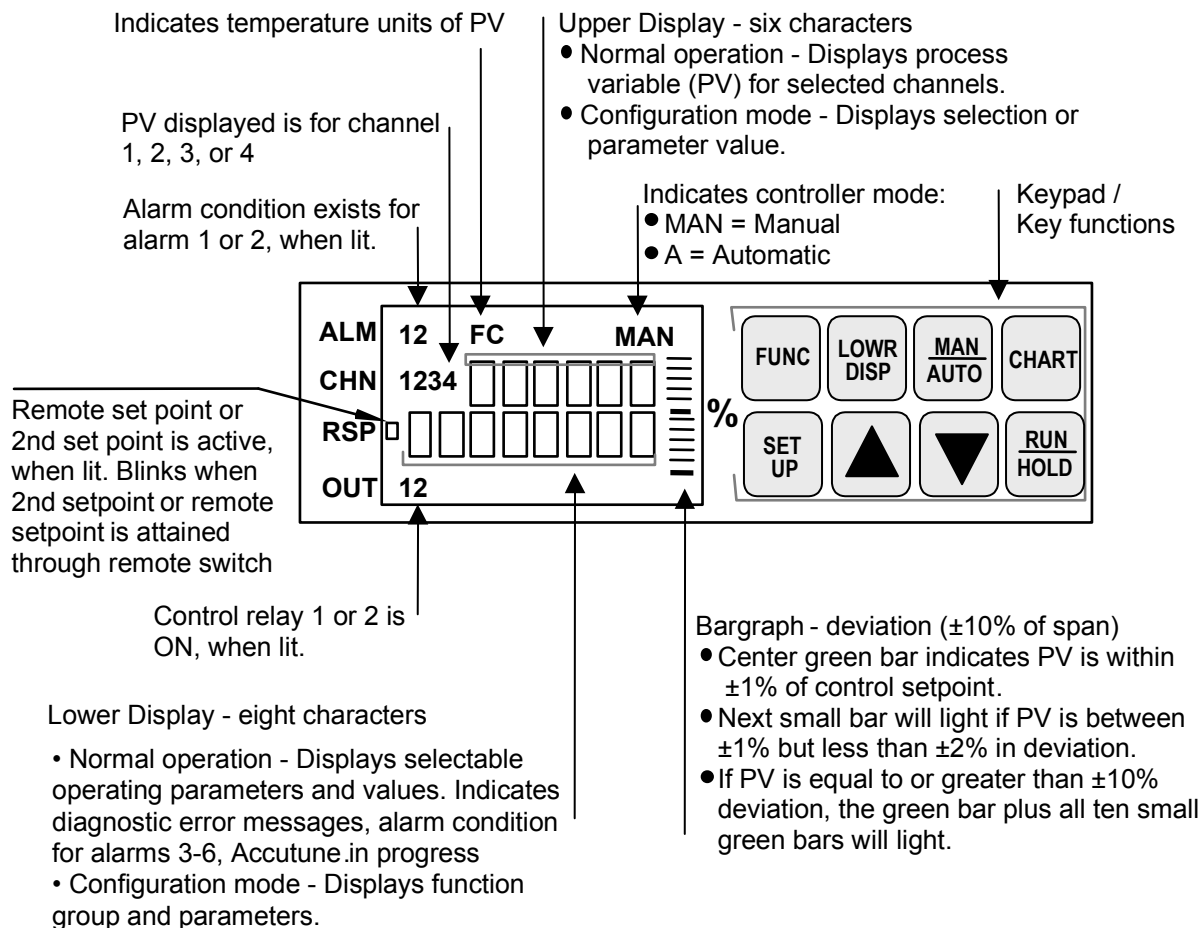

Figure 5-1 Operator Interface

## Meaning of indicators

During normal operation, the indicators will light for the reasons shown in Table 5-4.

**Table 5-4 Meaning of Indicators**

Indicator	Definition when lit
ALM 1 2	Alarm condition exists for alarm 1 or 2.*
CHN 1 2 3 4	PV displayed is for channel 1, 2, 3, or 4.
RSP	Remote Setpoint (when available) or 2nd setpoint is active.
OUT 1 2	Control relay 1 or 2 is ON.
A or MAN	Indicates the mode of operation: A = Automatic MAN = Manual
F or C or blank	Indicates the temperature units of PV: F = Fahrenheit C = Celsius
R or H or G or blank (in upper display)	Indicates the state of the setpoint ramp or program if enabled: R = Run H = Hold G = Guar Soak blank = Disabled
T	Totalizer
KEY ERR (in lower display)	Indicates parameter not available, not in set up mode, or key malfunction.

\* AL1 indicator can also mean the Interval Timer has timed out. Alarms 3-6 are indicated by a message on the lower display. See Table 5-7.

### Reading the deviation bargraph

In addition to the indicators, a bargraph containing 21 bars displays Process Variable (PV) deviation from Setpoint (SP).



#### ATTENTION

When CHN "1" indicator is lit, the bargraph display applies for Controller #1. It applies for Controller #2 when CHN "2" indicator is lit. Sequentially press the **LOWR DISP** key to light the appropriate CHN indicator (1 or 2) and view the corresponding controller displays.

- The green "on-control" bar lights when the PV is within  $\pm 1\%$  of setpoint.
- The 10 small green bars above the "on-control" bar light for each positive deviation up to  $+10\%$  and the 10 below light for each negative deviation down to  $-10\%$ . If the process deviation is greater than  $\pm 10\%$ , the "on-control" bar and the specific small green bars light.

Figure 5-2 shows how the deviation bargraph works.

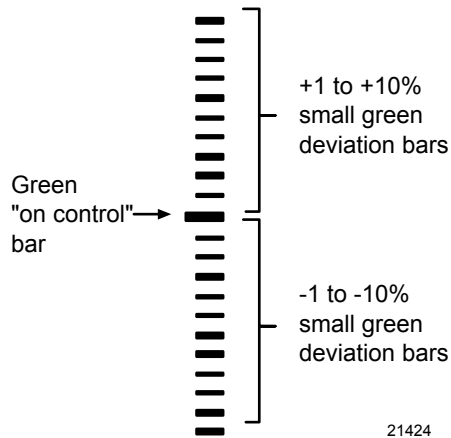

**Figure 5-2 Deviation Bargraph**

### Viewing the operating parameters

The upper display is a six-character display, four of which show the value of the PV during normal operation.

- The lower display is an eight-character display. During normal operation, you can view various operating parameters. Press the **LOWR DISP** key to scroll through the operating parameters listed in Table 5-5.
- The lower display shows only those parameters and their values that apply to your specific model and the way in which it was configured.
- You can configure the lower display to scroll through the items in Table 5-5 at an interval of 1, 2, or 3 seconds. Refer to *Subsection 3.19 – Options Set Up group, function prompt “SCROLL”* to make your selection.

Pressing the **LOWR DISP** key will freeze the lower display at the presently viewed item; pressing it again will advance to the next item and scrolling will resume.

- Pressing **▼** while pressing **LOWR DISP** will scroll backwards.

For recorders with two controllers (both enabled) remember that any controller-related values displayed correspond with the lighted CHN indicator — “1” means that the values apply for Controller #1 and “2” means that the values apply for Controller #2.

**Table 5-5 Lower Display Key Parameter Prompts**

Prompt	Description
<b>OUT**</b>	Output Value in Percent (%). Note that the output can only be adjusted through the raise/lower keys when the controller in manual mode. (Estimated motor position for 3 Position Step Control)
<b>SP**</b>	Local Setpoint 1. Also current setpoint of SP Ramp, or SP Ramp/Soak Program.
<b>SPN</b>	Current setpoint for setpoint rate applications.
<b>2SP**</b>	Local Setpoint 2 (where remote setpoint does not apply)
<b>RSP</b>	Remote Setpoint (when configured)
<b>1IN</b>	Value of Channel 1 input (if Loop1 is a derived PV)
<b>2IN</b>	Value of Channel 2 input (when available)
<b>3IN</b>	Value of Channel 3 input (when available)
<b>4IN</b>	Value of Channel 4 input (when available)
<b>DEV</b>	PV deviation from setpoint ( $\pm 999.9$ maximum)
<b>EU</b>	Engineering units that PV represents (when available)
<b>RH</b>	RH value in percent (%) (when available)
<b>PIDSETx**</b>	Tuning Parameter Set <b>x</b> = 1 or 2
<b>RAMP</b>	The time (minutes) remaining in the setpoint ramp
<b>#RA</b>	The time (minutes) remaining in the SP Ramp segment
<b>#SK</b>	The time (minutes) remaining in the SP Soak segment
<b>RECYC</b>	The number of recycles remaining to be run in the Setpoint Program

Prompt	Description
↙ □.□□ **	Time remaining in Timer function
↗ □.□□ **	Time elapsed in Timer function
TUNExXXX**	Accutune II indicator. <b>x</b> = Loop number (1 or 2). <b>XXX</b> = ON or OFF.

\*\*You can press ▲ or ▼ to change the value of this parameter.

### Diagnostic error messages

The DR4500A runs background tests to verify data and memory integrity. If there is a malfunction, an error message will blink in the lower display.

In the case of more than one simultaneous malfunction or alarm, each message will be shown in succession.

A list of error messages is contained in Table 5-6. If any of these error messages occur, refer to *Section 9 - Troubleshooting/Service* for information to correct the failure.

**Table 5-6 Error Messages**

Prompt	Description
EE FAIL	Unable to write to nonvolatile memory
FAILSAFE	Failsafe
INP1FAIL	Two consecutive failures of input 1 integration
INP2FAIL	Two consecutive failures of input 2 integration
INP3FAIL	Two consecutive failures of input 3 integration
INP4FAIL	Two consecutive failures of input 4 integration
INP1 RNG INP2 RNG INP3 RNG INP4 RNG	Input out-of-range
PV LIMIT	PV ± 10 % out-of-range
RV LIMIT	Remote Variable out-of-range Note: RV = (input 2 x ratio) + bias
CNFG ERR	Configuration data is in error.
CAL1 ERR	Working CAL TEST failure (Control Output #1, Input 1, Input 2)
CAL2 ERR	Working CAL TEST failure (Control Output #2, Input 3, Input 4)
BATT LOW	Battery failure



### Alarm and tuning messages

Alarms #3 through #6 and Accutune II for Control Loops #1 and #2 are indicated in the lower display.

In the case of more than one simultaneous diagnostic or alarm message, each message will be shown in succession.

**Table 5-7 Alarm and tuning messages**

Prompt	Description
<b>ALARM 3</b>	Indicates an alarm 3 action.
<b>ALARM 4</b>	Indicates an alarm 4 action.
<b>ALARM 5</b>	Indicates an alarm 5 action.
<b>ALARM 6</b>	Indicates an alarm 6 action.
<b>TUNING 1</b>	Indicates Accutune II in progress for Control Loop 1.
<b>TUNING 2</b>	Indicates Accutune II in progress for Control Loop 2.



#### **ATTENTION**

An active alarm will always provide an indication on the display but may not control its associated relay; that is, a higher priority function such as a control loop or timer may have control of the relay.

---

## 5.4 Operator Functions

### Actions an operator can initiate

An operator can do the following:

- Change the Control Mode (Auto/Man)
- Adjust the Output Manually
- Change the Setpoint
- Switch between Setpoints
- Run or Disable a Setpoint Ramp
- Run or Disable a Setpoint Program
- Switch between Two Sets of PID Values
- Run or Disable Control Loop Tuning
- Check the Alarm Setpoints
- Reset the Totalizer
- Run a Key Test

Note that some actions depend upon how the recorder was configured and the features supplied on your particular recorder model.

Refer to the following pages for functions and procedures.

### CHN indicator

Remember, for recorders with two controllers (both enabled) remember that any controller-related values displayed, including control mode, correspond with the lighted CHN indicator — “1” means that the values apply for Controller #1 and “2” means that the values apply for Controller #2. Sequentially press the **LOWR DISP** key to scroll through the displays and light the appropriate CHN indicator for controller-related values.

## 5.5 Operating Modes

### Available modes

The recorder can operate in any of three basic modes:

- Manual
- Automatic with Local Setpoint
- Automatic with Remote Setpoint

Manual and Automatic with Local setpoint are standard features and Automatic with Remote Setpoint is optional.

### Mode definitions

**Table 5-8 Operating Mode Definitions**

Operating Mode	Definition
MANUAL	When switched to manual mode, the recorder holds its output at the last value used during automatic operation and stops adjusting the output for changes in setpoint or process variable. Instead, you adjust the output by changing the value shown in the lower display. See “ <i>Selecting Modes</i> ”.
AUTOMATIC with LOCAL SETPOINT	In automatic local mode, the recorder operates from the local setpoint and automatically adjusts the output to maintain the setpoint at the desired value. In this mode you can adjust the setpoint. See “ <i>Setpoints</i> ”.
AUTOMATIC with REMOTE SETPOINT	In automatic remote mode, the recorder operates from the setpoint measured at input 2. Adjustments are available to ratio this input and add a constant bias before it is applied to the control equation. See <i>Subsection 3.12 Control Set Up Group</i> .

### What happens when you change modes

Table 5-9 explains what happens to the recorder when you switch from one mode to another.

**Table 5-9 Changing Operating Modes**

Operating Mode	Definition
Manual to Automatic Local Setpoint	The local setpoint is usually the value previously stored as the local setpoint.
Manual or Auto Local to Automatic Remote SP	The second input value with ratio and bias applied is used to calculate the control setpoint.
Automatic Remote SP to Manual or Auto Local Setpoint	If configured for RSP Tracking, when the recorder transfers out of remote setpoint, the last value of the control setpoint is inserted into the local setpoint. If RSP tracking is not configured, the local setpoint will not be altered when the transfer is made.

### Selecting manual or automatic mode

An alternate action switch places the recorder in automatic or manual mode of operation.

- Switching between manual and automatic will be bumpless, except when the PD+MR algorithm is selected.
- Table 5-10 includes procedures for selecting automatic or manual mode and changing the output while in manual.

**Table 5-10 Procedure for Selecting Automatic or Manual Mode**

Step	Operation	Press	Action/Result
1	Selecting automatic mode	<b>MAN</b> <b>AUTO</b>	Until "A" indicator is ON. The recorder regulates its output to maintain the PV at the desired setpoint.  <i>Upper Display:</i> shows the PV value <i>Lower Display:</i> shows <b>SP</b> and the setpoint value  The deviation bargraph indicates the PV deviation from the setpoint.
2	Selecting manual mode	<b>MAN</b> <b>AUTO</b>	Until "MAN" indicator is ON. The recorder holds its output at the last value used during automatic operation and stops adjusting the output for changes in setpoint or process variable.  <i>Upper Display:</i> shows the PV value <i>Lower Display:</i> shows <b>OUT</b> and the output value in %  The deviation bargraph indicates the PV deviation from the setpoint.
3	Adjust the output in manual mode	▲ or ▼	Adjust the output value while in manual mode.  <i>Upper Display:</i> shows the PV value <i>Lower Display:</i> shows <b>OUT</b> and the output value in %
4	Return to automatic mode	<b>MAN</b> <b>AUTO</b>	"A" indicator appears indicating automatic mode.

### Position proportional backup mode

This feature provides for Position Proportional models to automatically change to a Three Position Step algorithm if the slidewire input signal fails. This will maintain control of your process.

"SWFAIL" or "SW2FAIL" will flash in the lower display and the "OUT" display will show an estimated motor position WITHOUT a decimal point.

## 5.6 Setpoints

### Introduction

You can configure the following setpoints for the DR4500A recorder.

- A single local setpoint
- 2 local setpoints
- A local setpoint and a remote setpoint
- A computer setpoint.

These setpoints can be toggled by the **FUNC** key.

### Selecting the setpoint source

Use the procedure in Table 5-11 to select a single local setpoint source, a remote setpoint source, or two local setpoints.

**Table 5-11 Procedure for Selecting the Setpoint Source**

Step	Operation	Press	Action/Result
1	Enter set up mode	<b>SET UP</b>	Until the displays read: <i>Upper Display: SET UP</i> <i>Lower Display: CONTROL</i>
2	Display local setpoint source selections	<b>FUNC</b>	Until the displays read: <i>Upper Display: Setpoint source selections</i> <b>1LOCAL</b> <b>2LOCAL</b> <b>REMOTE</b> <i>Lower Display: SP SOURCE</i>
3	Select the desired source	<b>▲</b> or <b>▼</b>	Select the desired setpoint source in the upper display.
4	Return to control	<b>LOWR DISP</b>	Controller assumes normal control.

### Changing the local setpoints

Use the procedure in Table 5-12 to change either local setpoint value.

**Table 5-12 Procedure for Changing the Local Setpoint**

Step	Operation	Press	Action/Result
1	Select the setpoint	<b>LOWR DISP</b>	Until you see: <i>Upper Display: PV value</i> <i>Lower Display: SP or SP2 and the local setpoint value</i>
2	Change the value	<b>▲</b> or <b>▼</b>	Change the local setpoint to the value at which you want the process maintained. The deviation bargraph indicates PV deviation from setpoint.

### Switching between setpoints

You can switch between Local and Remote setpoints or between two Local setpoints when configured. Use the procedure in Table 5-13 to switch between setpoints.

**Table 5-13 Procedure for Switching Between Setpoints**

Step	Operation	Press	Action/Result
1	Switch between setpoints	<b>FUNC</b> or <b>LOWR DISP</b>	Alternately select Local setpoint 1 and Remote setpoint or switch between the 2 Local Setpoints. or Press appropriate key until you see the desired setpoint indicated.  <b>ATTENTION</b> "KEY ERROR" appears in the lower display if the remote setpoint or second local setpoint is not configured as a setpoint source, or if you attempt to change the setpoint while a setpoint ramp is enabled.
2	Change the <b>Local</b> setpoint value	▲ or ▼	The <b>REMOTE</b> setpoint cannot be changed at the keyboard.

### Setpoint selection indication

Table 5-14 shows how the indicators react and what the displays show for each type of setpoint.

**Table 5-14 Setpoint Selection Indication**

	Using Local Setpoint	Using Remote Setpoint	Using 2 <sup>nd</sup> Local Setpoint
<b>RSP Indicator</b>	OFF	ON (Note 1)	ON (Note 2) (Note 3)
<b>Upper Display</b>	PV	PV	PV
<b>Lower Display</b>	<b>SP</b> and the Local Setpoint Source	<b>RSP</b> and Remote Setpoint Value	<b>2SP</b> and the 2nd Local Setpoint Value
<b>To Change Setpoint Value</b>	Press ▲ or ▼	Cannot change the value at the keyboard.	Press ▲ or ▼

Note 1—RSP blinks when RSP is reached using Digital Input

Note 2—RSP solid for 2nd Setpoint

Note 3—RSP blinks for 2nd setpoint activated by Digital Switch

## 5.7 Single Setpoint Ramp

### Configuring the setpoint ramp

You can configure a single setpoint ramp to occur between the current local setpoint and a final local setpoint over a time interval of from 1 to 255 minutes. You can RUN or HOLD the ramp at any time.

### Procedure

Table 5-15 lists the procedure for configuring the Setpoint Ramp 1 or 2 parameters. The procedure for **Setpoint Program** is in *Section 6 – Setpoint Ramp/Soak Programming and Operation*.

**Table 5-15 Procedure for Configuring a Single Setpoint Ramp**

Step	Operation	Press	Action/Result
1	Select SP RAMP 1 or SP RAMP 2 Set Up group	<b>SET UP</b>	Until you see: <i>Upper Display: SET UP</i> <i>Lower Display: SP RAMP X</i> X = 1 or 2
2	Select the Setpoint Ramp function	<b>FUNC</b>	Until you see: <i>Upper Display: DISABL</i> <i>Lower Display: SP RAMP X</i>
3	Enable Setpoint Ramp	<b>▲</b>	Until you see: <i>Upper Display: ENABLE</i> <i>Lower Display: SP RAMP X</i>  NOTE: You cannot change the current local setpoint if the setpoint ramp function is enabled. Make sure SP PROG is disabled.
4	Set the Ramp Time	<b>FUNC</b>	Until you see: <i>Upper Display: The ramp time in minutes</i> <i>Lower Display: TIME MIN</i>
		<b>▲ or ▼</b>	Change the upper display value to the number of minutes in which you want the final setpoint to be reached.  Setting Range = 1 to 255 minutes  NOTE: Entering "0" implies an immediate step change to the final SP.
5	Set the Final Setpoint value	<b>FUNC</b>	<i>Upper Display: The final setpoint value</i> <i>Lower Display: FINAL SP</i>
		<b>▲ or ▼</b>	Change the upper display value to the desired final setpoint value.  Setting Range = within the setpoint limits

### Running the setpoint ramp

Running a setpoint ramp includes starting, holding, viewing the ramp time, ending the ramp and disabling it.

### Procedure

Table 5-16 lists the procedure for running the setpoint ramp.

**Table 5-16 Procedure for Running a Setpoint Ramp**

Step	Operation	Press	Action/Result
1	Put the controller into automatic mode	<b>MAN AUTO</b>	Until "A" indicator is ON and you will see:  <i>Upper Display: H</i> and the PV value <i>Lower Display: SP</i> and the present setpoint value
2	Set Start SP	▲ or ▼	Until the start setpoint value you desire is indicated in the lower display:  <i>Upper Display: H</i> and the PV value <i>Lower Display: SP</i> and the start setpoint value
3	Start the ramp	<b>RUN HOLD</b>	You will see:  <i>Upper Display: R</i> and the PV value <i>Lower Display: SP</i> and a changing setpoint value  NOTE: The value in the lower display will be increasing or decreasing toward the final setpoint value.  The PV value in the upper display and the pen trace will also change.
4	Hold the ramp at the current value	<b>RUN HOLD</b>	This holds the ramp at the current setpoint value.  Press again to continue run.  A "KEY ERROR" prompt appears if <b>RUN/HOLD</b> key is pressed while "SP RAMP" is disabled.
5	View the remaining ramp time	<b>LOWR DISP</b>	Until you see:  <i>Upper Display: R</i> or <i>H</i> and the PV value <i>Lower Display: RAMP XXXM</i> (time remaining)
6	End the ramp		When the final setpoint is reached, the "R" changes to "H" in the upper display and the recorder operates at the new setpoint.  <b>ATTENTION</b> Any time the local setpoint is different from the final setpoint value and the <b>RUN/HOLD</b> key is pressed — the ramp will start again.



Step	Operation	Press	Action/Result
7	Disable the setpoint ramp function	<b>SET UP</b>	Until you see: <i>Upper Display: SET UP</i> <i>Lower Display: SP RAMP X</i>
		<b>FUNC</b>	You will see: <i>Upper Display: ENABLE</i> <i>Lower Display: SP RAMP X</i>
		▲	You will see: <i>Upper Display: DISABL</i> <i>Lower Display: SP RAMP X</i>
8	Return to normal operating mode	<b>LOWR DISP</b>	Returns to normal operating mode.

## 5.8 Using Two Sets of Tuning Constants (PID Values)

### Introduction

You can use two sets of tuning constants for single output types and choose the way they are to be switched.

The sets can be:

- Keyboard selected
- Automatically switched when a predetermined Process Variable value is reached.
- Automatically switched when a predetermined Setpoint value is reached.

The following procedures show you how to:

- Select two sets
- Set the switchover value
- Set tuning constant value for each set
- Switch between two sets via the keyboard (without automatic switchover)



#### ATTENTION

For recorders with two controllers (both enabled) remember that any controller-related values displayed correspond with the lighted CHN indicator — “1” means that the values apply for Controller #1 and “2” means that the values apply for Controller #2.

### Select two sets

The procedure in Table 5-17 tells you how to select two sets of tuning constants.

**Table 5-17 Procedure for Selecting Two Sets of Tuning Constants**

Step	Operation	Press	Action/Result
1	Select Control Set Up group	<b>SET UP</b>	Until you see: <i>Upper Display:</i> <b>SET UP</b> <i>Lower Display:</i> <b>CONTROL</b>
2	Select PID SETS function	<b>FUNC</b>	You will see: <i>Upper Display:</i> Available selections are— <b>1 ONLY</b> – 1 set of constants <b>2 KEYBD</b> – 2 sets, keyboard selectable <b>2 PVSW</b> – 2 sets, auto switch at PV value <b>2 SPSW</b> – 2 sets, auto switch at SP value <i>Lower Display:</i> <b>PIDSETS</b>
		▲ or ▼	Select the type of PID set.

### Set switchover value

If you select 2 PVSW or 2 SPSW, you must set a value at which the sets will switch over.

The procedure in Table 5-18 shows you how to set this value.

**Table 5-18 Procedure for Setting Switchover Values**

Step	Operation	Press	Action/Result
1	Select switchover value function	<b>FUNC</b>  assuming you are still in Set Up group CONTROL	Until you see:  <i>Upper Display:</i> The switchover value <i>Lower Display:</i> <b>SW VALUE</b>
		▲ or ▼	Select the switchover value in the upper display.

### Set tuning constant values for each set

There are specific tuning constants that must be set for each set. The procedure in Table 5-19 shows you how to access these constants and change their values.

**Table 5-19 Procedure for Setting Tuning Constant Values**

Step	Operation	Press	Action/Result
1	Select Tuning Set Up group	<b>SET UP</b>	Until you see:  <i>Upper Display:</i> <b>SET UP</b> <i>Lower Display:</i> <b>TUNING</b>
2	Select the tuning constants	<b>FUNC</b>	Successively displays the following constants:  <i>Upper Display:</i> Tuning constant value <i>Lower Display:</i> <b>PROPBD</b> or <b>GAIN*</b> <b>RATEMIN*</b> <b>RSETMIN</b> or <b>RSETRPM*</b> <b>PROPBD2</b> or <b>GAIN2**</b> <b>RATE2MIN**</b> <b>RSET2MIN</b> or <b>RSET2RPM**</b>  *PIDSET1 – will be used when PV or SP, whichever is selected, is <b>greater</b> than the switchover value.  **PIDSET2 – will be used when PV or SP, whichever is selected, is <b>less</b> than the switchover value.
		▲ or ▼	Change the value of any of the above listed prompts in the lower display.

**Switch between two sets via the keyboard (without automatic switchover)**

This procedure is operational only if 2 PID SETS was configured at “CONTROL” set up group.

The procedure in Table 5-20 shows you how to switch from one set to another.

**Table 5-20 Procedure for Switching PID Sets from the Keyboard**

<b>Step</b>	<b>Operation</b>	<b>Press</b>	<b>Action/Result</b>
<b>1</b>	Access the PID set display	<b>LOWR DISP</b>	Until you see:  <i>Upper Display:</i> The PV value <i>Lower Display:</i> <b>PIDSETX</b> <b>X = 1 or 2</b>
		<b>▲ or ▼</b>	Change PIDSET1 to PIDSET2 or vice versa.

## 5.9 Using Accutune II

### Introduction

Accutune II provides foolproof, trouble-free on-demand tuning in the recorder. No knowledge of the process is required at start-up. The operator simply enters the desired setpoint and initiates the tuning. The recorder immediately starts controlling to the setpoint while it identifies the process, calculates the tuning constants and enters them into the tuning set up group, and begins PID control with the correct tuning parameters. This works with any process, including integrating type processes, and allows retuning at a fixed setpoint. The tuning sequence will cycle the recorder's output two full cycles between 0 % and 100 % (or low and high output limits) while allowing only a very small process variable change above and below the setpoint during each cycle.

- Accutune works for all control algorithms except ON/OFF.
- The recorder must be in Auto mode.
- Accutune works for integrating processes.

Enable/disable Accutune using the tuning set up group ACCUTUNE parameter described in *Section 4*.

Detailed instructions for using Accutune follow.

### Starting and Stopping Tuning with Accutune II

After "ACCUTUNE" has been enabled in the tuning set up group as described in *Section 4*, use the procedure in Table 5-21 to start tuning.

To abort tuning in progress, press the MAN/AUTO/RESET key to take the recorder out of Auto mode. The message "AbRT" (abort) will be displayed as the value of tuning set up group parameter "AT ERR". The tuning parameters will retain the values they had at the start of the Accutune operation.

**Table 5-21 Procedure for Starting Accutune II**

Step	Press	Action/Result
1	DISP until you see	Until you see <i>Lower Display: TUNExOFF (x = 1 or 2)</i> If "TUNExOFF" (tune off) does not appear, then Accutune is not enabled.
2	▲ or ▼	to toggle to  <i>Lower Display: TUNExON (x = 1 or 2)</i> Tuning will begin and the lower display will flash "TUNING". When tuning has been completed the lower display will again show "TUNExOFF".

### Using Accutune with Duplex (Heat/Cool) Control

“TUNE” can be done for applications using Duplex (Heat/Cool) control.

During tuning, Accutune II assumes SP 1 will cause a Heating demand, and then the calculated tuning parameters will be automatically entered as the first set of PID constants. Likewise, it assumes tuning at Local SP 2 will cause a Cooling demand, and the cooling parameters will be entered as the second set of PID constants.

### Procedure

After “ACCUTUNE” has been enabled in the tuning set up group as described in *Section 4*, use the procedure in Table 5-22 to start tuning. Note that control group parameter “SP SOURC” must be set to “2LOCAL” to enable the second setpoint.

To abort tuning in progress, press the MAN/AUTO key to take the recorder out of Auto mode. The message “AbRT” (abort) will be displayed as the value of tuning set up group parameter “AT ERR”. The tuning parameters will retain the values they had at the start of the Accutune operation.

**Table 5-22 Procedure for Using Accutune for Duplex Control**

Step	Press	Action/Result
<b>Heating Tuning</b>		
1	DISP	Until you see Setpoint 1. <i>Lower Display: SP nnn</i>
2	▲ or ▼	Until the value of Setpoint 1 is at the desired value within the Heat zone.  Make sure the recorder is in Auto mode. (“A” indicator lit.) If not, use the MAN/AUTO/RESET key to put the unit in Auto.
3	DISP	Until you see <i>Lower Display: UseSPn</i>  This is the prompt used to select the setpoint. If it is not “USESP1”, use ▲ or ▼ to switch to “USESP1”.
4	DISP	Until you see <i>Lower Display: TUNExOFF (x = 1 or 2)</i>  If “TUNExOFF” (tune off) does not appear, then Accutune is not enabled.
5	▲ or ▼	to toggle to <i>Lower Display: TUNExON (x = 1 or 2)</i>  Tuning will begin and the lower display will flash “TUNING”. The output will cycle between 50 % and 100 % (or high output limit). When tuning has been completed the lower display will again show “TUNExOFF”. The Heat tuning parameters are entered for the first set of PID constants in the tuning set up group.

Step	Press	Action/Result
<b>Cooling Tuning</b>		
6	DISP	Until you see Setpoint 2. <i>Lower Display: SP nnn</i>
7	▲ or ▼	Until the value of Setpoint 2 is at the desired value within the Cooling zone.
8	DISP	Until you see <i>Lower Display: Use SP1</i>
9	▲ or ▼	to toggle to <i>Lower Display: Use SP2</i>
10	DISP	<i>Lower Display: TUNExOFF</i>
11	▲ or ▼	to toggle to <i>Lower Display: TUNExON</i>  Tuning will begin and the lower display will flash "TUNING". The output will cycle between 0 % and 50 % (or low output limit). When tuning has been completed the lower display will again show "TUNExOFF". The Cool tuning parameters are entered for the second set of PID constants in the tuning set up group.

## 5.10 Alarm Setpoints

### Introduction

- An alarm consists of a relay contact and an operator interface indication. The alarm relay is de-energized if Alarm Setpoint 1 or Setpoint 2 is exceeded.
- The alarm relay is energized when the monitored value goes into the allowed region by more than the hysteresis.
- There are twelve alarm setpoints, two for each alarm.
- The type and state (High or Low) is selected during configuration: see *Section 3 - Configuration* for details.



#### ATTENTION

An active alarm will always provide an indication on the display but may not control the relay; that is, a higher priority function such as a control loop or timer may have control of the relay.

### Procedure for displaying the alarm setpoints

The procedure for displaying and changing the alarm setpoints is listed in Table 5-23.

**Table 5-23 Procedure for Displaying or Changing the Alarm Setpoints**

Step	Operation	Press	Action/Result
1	Access the Alarm Set Up group	<b>SET UP</b>	Until you see: <i>Upper Display:</i> <b>SET UP</b> <i>Lower Display:</i> <b>ALARM X</b> <b>X = 1, 2, 3, 4, 5, 6</b>
2	Access the Alarm Setpoint Values	<b>FUNC</b>	Successively displays the alarm setpoints and their values.  <i>Upper Display:</i> The alarm setpoint value <i>Lower Display:</i> <b>AXS1 VAL</b> – Setpoint 1 value of alarm 1, 2, 3, 4, 5, or 6 <b>AXS2 VAL</b> – Setpoint 2 value of alarm 1, 2, 3, 4, 5, or 6
		<b>▲</b> or <b>▼</b>	Change any alarm setpoint value you select in the upper display.
3	Return to normal operation	<b>LOWR DISP</b>	Returns to normal operation.



## 5.11 Three Position Step Control Algorithm

### Introduction

The Three Position Step Control algorithm allows the control of a valve (or other actuator) with an electric motor driven by two controller output relays; one to move the motor upscale, the other to move it downscale, without a feedback slidewire linked to the motor shaft.

### Estimated motor position

The Three Position Step Control algorithm provides an output display (“OUT”) which is an estimated motor position since the motor is not using any feedback.

Although this output indication is only accurate to a few percent, it is corrected each time the controller drives the motor to one of its stops (0 % or 100 %).

It avoids all the control problems associated with the feedback slidewire (wear, dirt, noise).

When operating in this algorithm, the estimated “OUT” display is shown to the nearest percent (i.e., no decimal).

### Displaying the motor position

Table 5-24 lists the procedure for displaying the motor position.

**Table 5-24 Procedure for Displaying the 3PSTEP Motor Position**

Step	Operation	Press	Action/Result
1	Access the displays	<b>LOWR DISP</b>	Until you see:  <i>Upper Display:</i> The PV value <i>Lower Display:</i> <b>OUT</b> Estimated 3PStep motor position

### Power up output

When the controller powers up after a power outage, the position of the motor will correspond to whatever was configured at set up group prompt “CONTROL”, function prompt “PWR OUT”, selection LAST or FAILSAFE. Refer to *Subsection 4.8, Table 4-7* for definition of each selection.

## 5.12 Digital Input Option (Remote Switching)

### Introduction

The digital input option detects the state of external contacts wired to it. On contact closure, the controller responds according to how each digital input is configured.

- Make your selection under set up group “CONTROL1” or “CONTROL2”, function group prompt “REM SW”: see *Subsection 3.12—Table 3-9* or *Subsection 4.8—Table 4-7*.

### Action on contact closure

Table 5-25 lists the configuration prompt selections, the “Action on Contact Closure”, and the display indication for each selection available.

**Table 5-25 Digital Input Option Action on Contact Closure**

REM SW Selections	Display Indication	Action on Contact Closure
None	None	No Digital Input selection
To MAN	“MAN” blinks	Puts the controller into manual mode; contact open returns the controller to former mode unless <b>AUTO/MAN</b> key is pressed while digital input is active.
To LSP	“RSP” blinks	Puts the controller into local setpoint 1 (switches out of remote). When contact opens, the controller returns to former operation unless the <b>FUNC</b> key is pressed while digital input is active.
To 2SP	“RSP” blinks	Puts the controller into local setpoint 2.
To DIR	None	Selects direct controller action (transfer if in reverse).
RN/HOLD	“H” blinks in upper display	Suspends setpoint program or setpoint ramp. <ul style="list-style-type: none"> <li>• Keyboard takes priority over external switch for RUN/HOLD function.</li> <li>• Contact open runs the program or ramp.</li> <li>• If initially in the HOLD state, close then open the contact to remotely start the SP ramp or Program</li> </ul>
TUNE	TUNING x	Initiates Accutune

### Keyboard operation

If a particular mode or parameter is selected by the contact closure, using the keyboard to select the same parameter ensures that the selected mode will be maintained after the remote digital switch is reopened.

## 5.13 Resetting and Displaying Totalizer Value

### Introduction

If the totalizer is enabled and has been configured to allow resetting, you can reset the current totalizer value as follows.

- Refer to *Section 3 - Configuration*, under set up prompt “TOTAL 1” for Input #1 or “TOTAL 2” for Input #2 to enable the totalizer function and allow the totalizer to be reset.
- Refer to the procedures that follow to:
  - reset the totalizer locally,
  - reset the totalizer using the Wake Time feature,
  - reset the totalizer externally (switch),
  - display the totalizer value.

### Resetting the totalizer locally

Follow the procedure in Table 5-26 to reset the totalizer value.

**Table 5-26 Procedure for Resetting the Totalizer**

Step	Operation	Press	Action/Result
1	Access the Totalizer Set Up group	<b>SET UP</b>	Until you see: <i>Upper Display: SET UP</i> <i>Lower Display: TOTAL 1 or TOTAL 2</i>
2	Allow Totalizer Reset	<b>FUNC</b> once	You will see: <i>Upper Display: Ex XXX</i> <i>Lower Display: (a value)</i>
		<b>FUNC</b> again	You will see: <i>Upper Display: NO</i> <i>Lower Display: RSET TOT</i>
		▲ or ▼	Change NO to YES in the upper display. <b>ATTENTION</b> Function prompt “RSETABLE” must be set to “LOCAL”.
3	Return to normal operation	<b>LOWR DISP</b>	Returns to normal operation.

### Resetting the totalizer using the Wake Time feature

To reset the totalizer using the Wake Time feature, set the Wake Time ("WAKE MIN", "WAKE HR", "WAKE DAY", "WAKE MON" in *Subsection 3.9 – Time Set Up Group*) as desired. Then set function prompt "RSETABLE" (*Subsection 3.10 – Totalizer Set Up Group*) to "TIME". When the configured Wake Time value is reached, the totalizer will reset to "0".

### External totalizer reset

The totalizer can be reset to “0” from external switch #1 or external switch #2. Refer to *Subsection 3.10 – Totalizer Set Up Group* and set function prompt “RSETABLE” to “EXT SW1” or “EXT SW2”.

### Displaying the totalizer value

Follow the procedure in Table 5-27 to display the totalizer value.

**Table 5-27 Procedure for Displaying the Totalizer Value**

Step	Operation	Press	Action/Result
1	Alternating Totalizer Display	<b>LOWR DISP</b>	Until you see:  <i>Upper Display: tPV VALUE</i> <i>Lower Display: (total value)</i>  <b>ATTENTION</b> When two totalizers are configured, notice that channels #1 and #2 totalizer values are alternately displayed.
2	Display Channel #1 totalizer	▲ or ▼	Until CHN “1” indicator lights.  <i>Upper Display: 1TPV VALUE</i> <i>Lower Display: (total value)</i>
3	Display Channel #2 totalizer	▲ or ▼	Until CHN “2” indicator lights.  <i>Upper Display: 2TPV VALUE</i> <i>Lower Display: (total value)</i>
4	Return to Alternating Display	▲ and ▼  simultaneously	You will see:  <i>Upper Display: SCAN</i> <i>Lower Display: (total value)</i>  After the keys are released, the upper display alternately shows #1, #2 PV values while lower display shows #1, #2 totalization values.
5	Return to Normal PV Display	<b>LOWR DISP</b>	Returns to normal PV display.

## 5.14 Monitoring the External Event Operation

### Event pen function

If Function prompt “PEN IIN” under Set-up prompt “PEN 1” has been configured as DGTL1 or DGTL2, the pen (channel) operates as an “event pen” and tracks the remote contact (switch) closure by way of the digital 1 or digital 2 input wired to the alarm output/digital input printed circuit board.

### Event pen operation

When the switch opens, the trace for the channel tracks at the configured OFF position (0-100 %) on the chart.

When the switch closes, the trace tracks at the configured ON position (0-100 %) on the chart and tracks at this position until the switch is opened.

Thus, the “Event Pen” record makes it easy to monitor the on/off operation of an external event.

## 5.15 Maximizing Pen Life

### Steps for maximizing pen life

Table 5-28 lists nine steps that will help to maximize the life of your chart pen.

**Table 5-28 Maximizing Pen Life**

Step	Action
1	Store the chart paper in a cool, clean dry place where the temperature does not exceed 40 °C (104 °F) and the humidity is below 65 % RH.
2	Do not expose the pen tip and chart paper to abrasive chemicals or dust that cause excessive pen wear.
3	If the recorder is used in a dusty atmosphere, provide a positive 'clean air purge' to minimize dust particle accumulation on the chart paper.
4	Periodically clean the pen arm using a cotton swab dipped in alcohol. This is more important when the recorder is located in a dusty environment and no 'clean air purge' is used.
5	Never let the pen tip ride on the chart plate when the paper is not present. Use the pen lifter to raise the arm when changing the paper.
6	Keep the door closed while recording.
7	Always insert the pen arm tip into the shipping sponge when storing or shipping the recorder.
8	Be sure that the chart paper lays flat against the chart plate. Any ripple in the paper will cause light pen printing.
9	Be sure the chart hub assembly is pushed onto the motor shaft so that it is flush with the chart plate.

## 5.16 Routine Maintenance

### Introduction

The DR4500A recorder does not require any periodic maintenance as such. But, you will have to clean the pen tip, and replace the chart and optional chart lamp as required.



#### WARNING

Do not lubricate the plastic gears on the chart and pen motors.

### Cleaning the pen tip

Follow the procedure in Table 5-29 to clean the pen tip.



#### CAUTION

Cleaning frequency varies with the recording application environment.

**Table 5-29 Cleaning the Pen Tip**

Step	Action
1	Open the recorder door.
2	Pull the pen lifter up in order to raise the pen from the chart.
3	Carefully clean the pen tip with a cotton swab that has been dipped in alcohol.
4	Push the pen lifter down to lower the pen.
5	Close the door and resume normal operation.

### Replacing a burned-out chart lamp (optional)

Follow the procedure in Table 5-30 to replace a burned-out chart lamp.

**Table 5-30 Replacing a Chart Lamp**

Step	Action
1	Open the recorder door and remove power.
2	Unscrew and remove the hood from the lamp assembly.
3	Push the (bayonet-type) lamp in and turn it counterclockwise to remove it from the socket.
4	Reverse step 3 and install the replacement lamp (General Instrument type 1828 or equivalent) in the socket.
5	Replace the hood on the lamp assembly.
6	Close the door and apply the power.

## 5.17 Installing/Replacing Chart

### Installing/replacing chart procedure

Follow the procedure in Table 5-31 to install/replace the chart.



#### CAUTION

Store replacement charts in a dust-resistant location. Otherwise, accumulated dust on the chart may cause excessive pen tip abrasion which can shorten expected pen life. In addition, you may want to air purge the case if the recorder is mounted in an extremely dusty environment.

**Table 5-31 Installing/Replacing the Chart**

Step	Action
1	Open the recorder door.
2	Press the <b>CHART</b> key. The pen moves to and stops at the outer limit of pen travel near the edge of the chart. Also, chart rotation stops and the date and time appear in the displays.
3	Pull the pen lifter up to raise the pen from the chart.
4	Carefully remove the used chart from the hub and retaining clips (do not remove the hub adapter).
5	Install the new chart so that its edges are under the four retaining clips and its small alignment hole is over the alignment pin on the hub (that is, press the chart down completely around the hub adapter).
6	Push the pen lifter down to lower the pen.
7	<p>Press the <b>CHART</b> key. The recorder goes to the "CHART RUN." The date and time in the display is replaced by the parameter prompt/value that was last selected using the <b>LOWR DISP</b> key.</p> <p><b>ATTENTION</b> The recorder has a non-volatile memory. You can reset the processor by cycling the power, but it will have no affect on any data stored. One portion of this stored data is how many motor steps remain in the 7200 steps contained in 360 degrees of chart rotation. The counter that holds this data is reset by going from "CHART HOLD" to "CHART RUN."</p> <p>If, in the "CHART" set up group, the recorder is configured for "HEADER" (YES), a new header is printed, then the pen recording of input values resumes.</p> <p>If "HEADER" (NO) is configured, recording resumes immediately.</p>
8	Be sure to keep the door closed during operation to minimize dust collection on the chart.



## 5.18 Chart Operation

### Normal operation

The recorder functions differently if “NO CONTINUE” or “YES CONTINUE” is selected in Configuration Setup Group “CHART,” function prompt “CONTINUE.” Refer to *Subsection 3.8* for selection instructions.

### **NO CONTINUE Operation**

- A header is printed (only if “HEADER YES” is selected in Configuration Setup Group “CHART,” function prompt “HEADER.” Refer to *Subsection 3.8* for selection instructions.)
- Graph starts with a major time line if not a standard chart.

If standard chart, graph starts with a solid line indicating where the chart began. An incomplete segment will be printed with *no* time or text information up to the next hour mark. At that point, a new time line will be printed, on the hour. The initial incomplete segment will be completed, including any partially printed range values, at the end of the rotation. Additionally, any time or text information being printed when the chart hits 7200 steps will continue to be completed.

- Chart motor takes 7200 steps printing graph, time lines, and PV.
- Counter decrements to 0.
- Chart stops rotation.

### **YES CONTINUE Operation**

- A header is printed (only if “HEADER YES” is selected in Configuration Setup Group “CHART,” function prompt “HEADER.” Refer to *Subsection 3.8* for selection instructions.)
- Graph starts with a major time line.
- Chart motor takes 7200 steps printing graph, time lines, and PV.
- Counter decrements to 0.
- Graph stops printing.
- PV prints forever (or until the next transition from “CHART RUN” to “CHART HOLD.”)

### Remote chart operation

The Remote Chart feature can be configured to activate on any one of six events. Refer to *Subsection 3.8—Table 3-5* or *Subsection 4.4—Table 4-3* under Function prompt “REMCHT” to select an event.

When the Remote Chart feature is activated, there are three chart modes as defined in Table 5-32.

**Table 5-32 Remote Chart Modes**

Mode	Definition
<b>HOLD</b>	<p>HOLD is the mode when you are changing the paper or when the chart has completed.</p> <p>HOLD is indicated by the “CHT HLD” flashing in the lower display.</p>
<b>READY</b>	<p>You enter the READY mode from the Hold mode by pressing the <b>CHART</b> key <i>once</i>.</p> <p>When in the READY mode, the lower display will flash “REM CHT”.</p> <p>READY is the “armed” mode where the remote events are allowed. The chart is waiting to be activated by whatever event has been configured or by pressing <b>CHART</b> again. It is not retriggerable.</p>
<b>RUN</b>	<p>RUN is the mode where the chart has received its trigger.</p> <p>The chart will remain in RUN until the chart is finished (for non-continue charts) or until you press the <b>CHART</b> key.</p> <p>When the <b>CHART</b> key is pressed during the RUN mode, the chart will enter the HOLD mode.</p> <p>RUN mode can be <i>forced</i> from the READY mode by pressing the <b>CHART</b> key.</p>

All modes are saved in battery backed RAM and will be maintained over power cycles.

### Recovery from a power loss

The chart will operate as listed below when power is restored after a power loss.

- Recorder shuts down with the remainder of the 7200 motor steps stored.
- The processor goes through memory self-test when power is restored.
- The recorder prints a new motor time line if not a standard chart.  
If standard chart, text information will be lost until the next hour mark.
- The chart counter starts to decrement from the motor step value stored at power loss.
- Normal chart operation resumes.
- A new “HEADER” is *not* printed.
- If power is not interrupted again and normal operation is allowed to continue, the time and date will be printed behind the new major time line. This documents the time that power was restored.



**ATTENTION**

Multiple major time divisions on varying time bases indicate power or operator problems.

---

## 6. Setpoint Ramp/Soak Programming and Operation

### 6.1 Overview

#### Introduction

As an option, the recorder can support the programming of a 36-segment setpoint program containing 18 ramp segments and 18 soak segments. In a ramp segment the setpoint value is changed as specified during configuration. The ramp is configured in terms of ramp time or ramp rate, depending on how you have configured the RAMPUNIT parameter. During a soak segment the setpoint is held at the specified value.

For each control loop you can build up to 6 profiles using any number of consecutive segments of the program.

Odd-numbered segments are always ramp segments. Even-numbered segments are always soaks. These ramp and soak segments can be used in up to six programs. You designate the beginning and end segments to determine where the program will start or stop.

- Every profile must start with a ramp segment and end on a soak segment.
- Control Loop must have Setpoint Source set to ILOCAL.
- Control Loop 1 uses SP RAMP1, Control Loop 2 uses SP RAMP2. SP RAMP1 and SP RAMP2 are the prompts under which the setpoint program is configured.
- Recorder must be set to use SP1 (setpoint 1).
- Only contiguous segments can be used by a profile.
- There can be overlap between programs. For example, Profile 1 could use Segments 1, 2, 3, 4, 5, and 6. Profile 2 could be configured to begin with Segment 5 and end with Segment 8.

This section contains instructions for setting up a setpoint program, and for executing the program at runtime.

Note that Section 4 contains instructions for using the setpoint ramp or setpoint rate. **The SP RAMP (setpoint ramp) and SP RATE (setpoint rate) parameters described in Section 4 must be set to DISABL (disabled) if a setpoint program is to be used.**



#### ATTENTION

If power is lost during execution of a program, upon power-up the recorder will use the last setpoint value prior to the beginning of the setpoint program. The program is placed in hold at the beginning. The Manual/Auto mode will be as configured under "POWER UP" in the "CONTROL" group.

---

**What's in this section?**

This section contains the following information:

<b>Topic</b>	<b>See Page</b>
6.2 Setpoint Program Contents	175
6.3 Drawing a Ramp/Soak Profile	178
6.4 Entering the Setpoint Program Data	183
6.5 SP RAMP1 and SP RAMP2 Set Up Group	185
6.6 Setpoint Program Profiles Set Up Group	187
6.7 Setpoint Program Segments Set Up Group	189
6.8 Setpoint Program Event Set Up Group	192
6.9 Run/Monitor the Program	196

## 6.2 Setpoint Program Contents

### What you will configure

You will configure all the data that is relevant to each ramp and soak segment for a given setpoint versus time program (profile). The recorder will prompt you through the sequence of segments and associated functions. These prompts and functions are described below.

### Recycle number

The recycle number allows the program to recycle a specified number of times from beginning to end.

- Range = 0 to 99

### Guaranteed soak

A SOAK DEV (soak deviation) parameter is provided. If its value is not zero, then soaking will be frozen for each segment until the difference (plus or minus) between PV and SP is less than or equal to the value of SOAK DEV.

There are no guaranteed soaks whenever SOAKDEV = 0. In this case, soak segments start timing soak duration as soon as the soak setpoint is first reached, regardless of where the process variable remains relative to the soak setpoint during the duration of the segment.

The decimal location corresponds to input 1 decimal selection.

### Profile number

The profile number specifies which of up to six profiles will run. Up to 6 profiles can be configured out of any even number of consecutive segments from the 36 segments configured.

### Program state

The program state selection determines the program state after completion.

The selections are:

- DISABL = program is disabled
- HOLD = program on hold

### Recovery

If Recovery is enabled the setpoint program will continue from where it left off after the last power down.

### Program End State

This determines the status of the recorder upon completion of the profile. The selections are:

- LAST SP = hold at the last setpoint in the program
- F SAFE = Manual mode, Failsafe Output

## Profile Start and Profile End

These selections let you specify the segments that will comprise each of the 6 profiles. The first segment must be a ramp (odd-numbered segment) and the last segment must be a soak (even-numbered).

## Ramp unit

The ramp unit selection determines the engineering units for the ramp segments.

The selections are:

- TIME = Hours:Minutes
- EU-H = Degrees/Hour    OR    EU-M = Degrees/Minute

## Ramp time or rate segments

A ramp segment is used to change the setpoint to the next soak setpoint value in the program.

- Ramps are odd-numbered segments. Segment 1 will be the initial ramp.
- Ramps are specified in terms of either:

TIME\* - Hours:Minutes    Range = 0-99 hrs:59 min.

or

EU-M\* - Degrees/Minute    Range = 0 to 999

EU-H\* - Degrees/Hour

\* *The selection of time or rate is made at prompt "RAMP UNIT"*

Set this prompt before entering any Ramp information.



### ATTENTION

Entering "0" will imply an immediate step change in setpoint to the next soak.

---

## Soak segments

A soak segment is a combination of soak setpoint (value) and a soak duration (time).

- Soaks are even-numbered segments.
- Segment 2 will be the initial soak value and soak time.
- The soak setpoint range value must be within the setpoint high and low range limits in engineering units. (Specify the setpoint range with SP HI and SP LO in the control group as described in Section 4.)
- Soak time is the duration of the soak and is determined in:

TIME - Hours:Minutes    Range = 0-99 hrs:59 min.

## Segment Events

Each segment can be programmed to trigger an alarm which in turn deenergizes the associated relay. The selected alarm must be programmed as an event type for this to occur. Selections are:

ALARM 1 – ALARM 6.

Segment events will not trigger a relay if that relay is configured with one of these higher priority functions:

- Control loop output
- Interval Timer
- alarm type other than “Event”.

See Table 6-7.

### **Digital input (remote) operation**

Program can be placed in RUN or HOLD state through a remote dry contact connected to optional digital input terminals. The Control Loop parameters REM SW and REM SW2 parameters must be configured as RN/HLD to support this function. The valid states of the contacts are:

- RUN—contact closure places program in HOLD state
- HOLD—contact open places program in RUN state

## 6.3 Drawing a Ramp/Soak Profile

### Ramp/soak profile example

Before you perform the actual configuration, we recommend that you draw your Ramp/Soak profiles in the space provided on the blank graphs and fill in the associated information on the worksheet. An example of a Ramp-Soak Profile using the first twelve segments for Profile 1 is shown in Figure 6-1. Start setpoint in this example is at 200 °F. Assume each soak segment is desired to trigger an event. Assume you are configuring the program to be used by Control Loop1 (SP RAMP1).

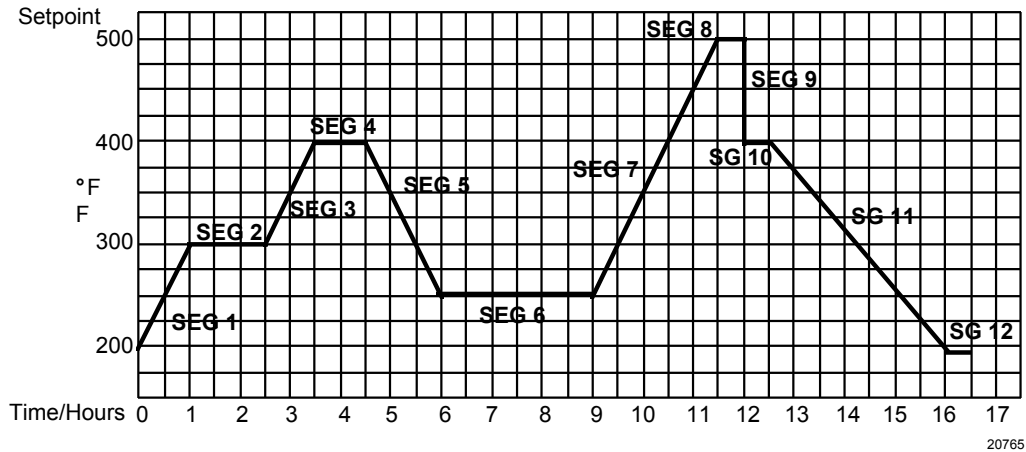

Figure 6-1 Ramp/Soak Profile Example



**Table 6-1 Parameter settings for example 12-step profile**

Prompt	Function	Segment	Value	Prompt	Function	Segment	Value
SP RAMP1	Settings for Control Loop 1 ramp			SEG7RAMP	Ramp	7	2hrs:30min.
SP PROG	Enables SP prompts.		ENABLE	SEG8 SP	Soak SP	8	500
RECYCLES	Number of Recycles		2	SEG8TIME	Soak Time	8	0hr.:30 min.
SOAK DEV	Deviation Value		0	SEG9RAMP	Ramp	9	0
PROFILE	Number of profile to run		1	SEG10 SP	Soak SP	10	400
STATE	Program State at end		HOLD	SEG10TIME	Soak Time	10	0hr.:30 min.
RECOVERY	Program resumes after power interruption		ENABLE	SEG11RAMP	Ramp	11	3hrs:30min.
PROG END	SP value after last segment		LAST SP	SEG12 SP	Soak SP	12	200
SPP SEGS	Settings for segments			SEG12TIME	Soak Time	12	0hr.:30 min.
PR1 STRT	Profile 1 Start Seg.		1	SEG1 EV	Event	1	NONE
PR1 END	Profile 1 End Seg.		12	SEG2 EV	Event	2	ALARM1
RAMPUNIT	Ramp Units		TIME	SEG3 EV	Event	3	NONE
SEG1 RAMP	Ramp	1	1 hr.	SEG4 EV	Event	4	ALARM1
SEG2 SP	Soak SP	2	300	SEG5 EV	Event	5	NONE
SEG2TIME	Soak Time	2	1hr.:30 min.	SEG6 EV	Event	6	ALARM1
SEG3RAMP	Ramp	3	1hr.	SEG7 EV	Event	7	NONE
SEG4 SP	Soak SP	4	400	SEG8 EV	Event	8	ALARM1
SEG4TIME	Soak Time	4	1 hr.	SEG9 EV	Event	9	NONE
SEG5RAMP	Ramp	5	1hr.:30 min.	SEG10 EV	Event	10	ALARM1
SEG6 SP	Soak SP	6	250	SEG11 EV	Event	11	NONE
SEG6TIME	Soak Time	6	3hrs.:0min.	SEG12 EV	Event	12	ALARM1

*Reminder:* There are up to 36 segments available for inclusion in a profile. The above example uses only the first 12.

**Profile graphs**

Draw your six ramp/soak profiles on the graphs below and fill in the associated information in the worksheets that follow in the next sections. This will give you a permanent record of your program and will assist you when entering the ramp and soak values.

**Profile 1**

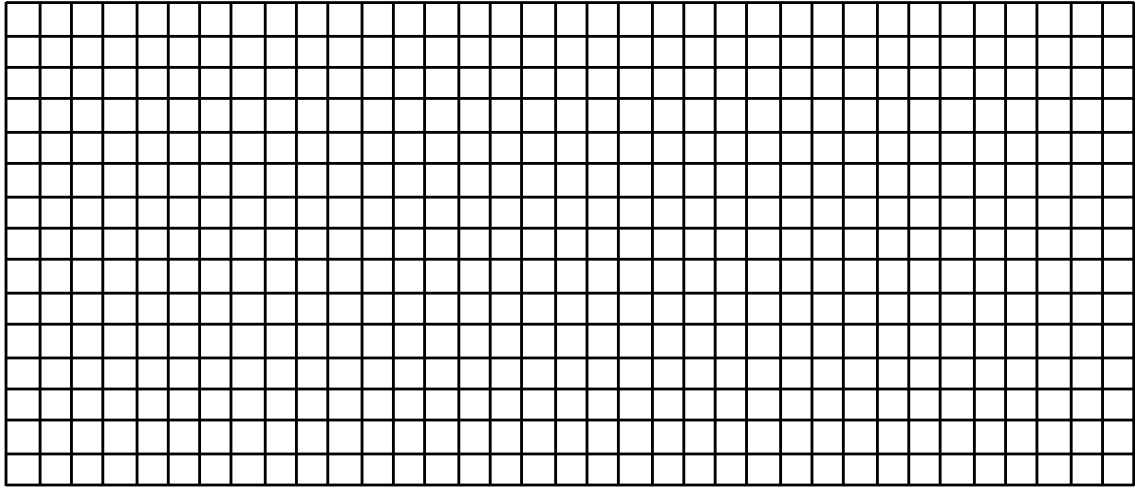

20766

**Profile 2**

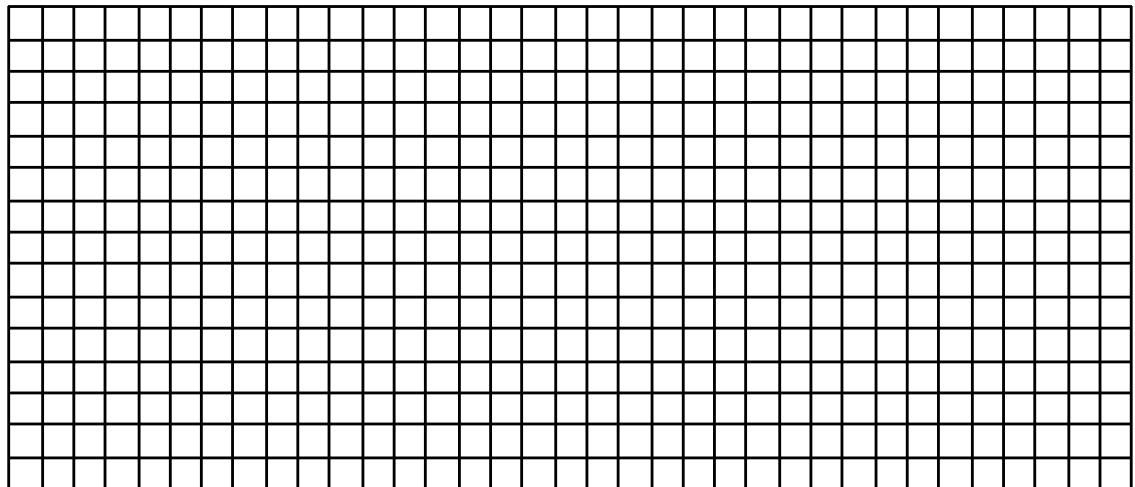

20766

**Profile 3**

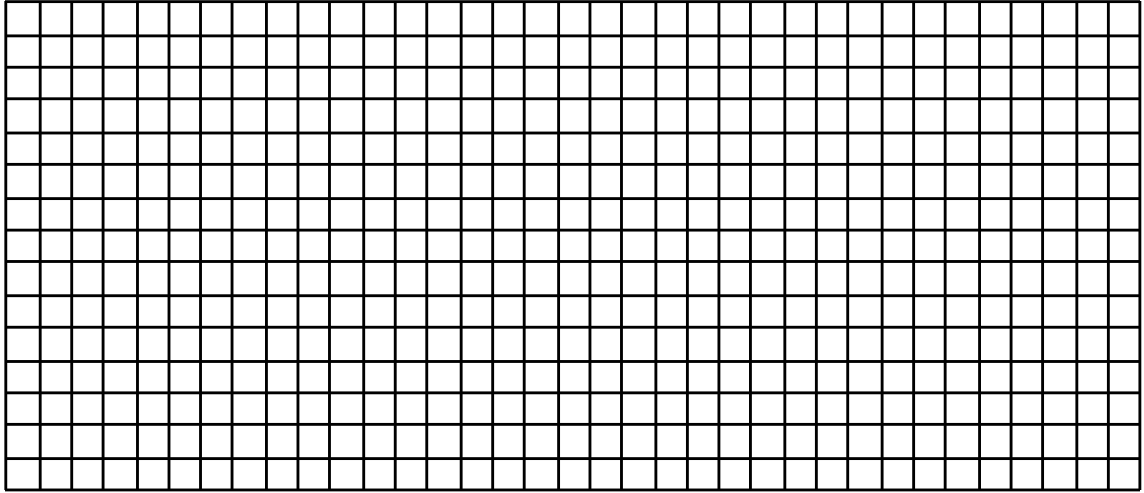

20766

**Profile 4**

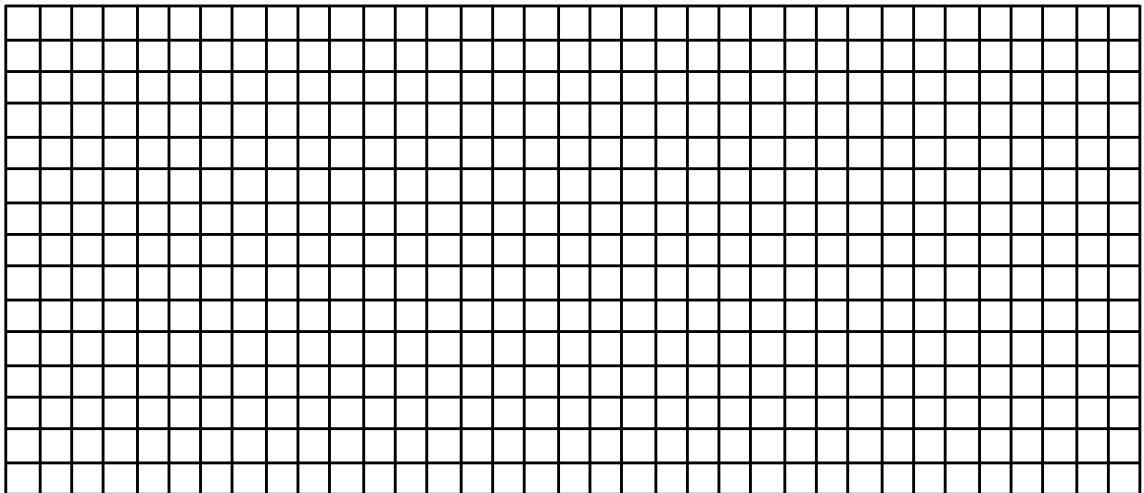

20766

**Profile 5**

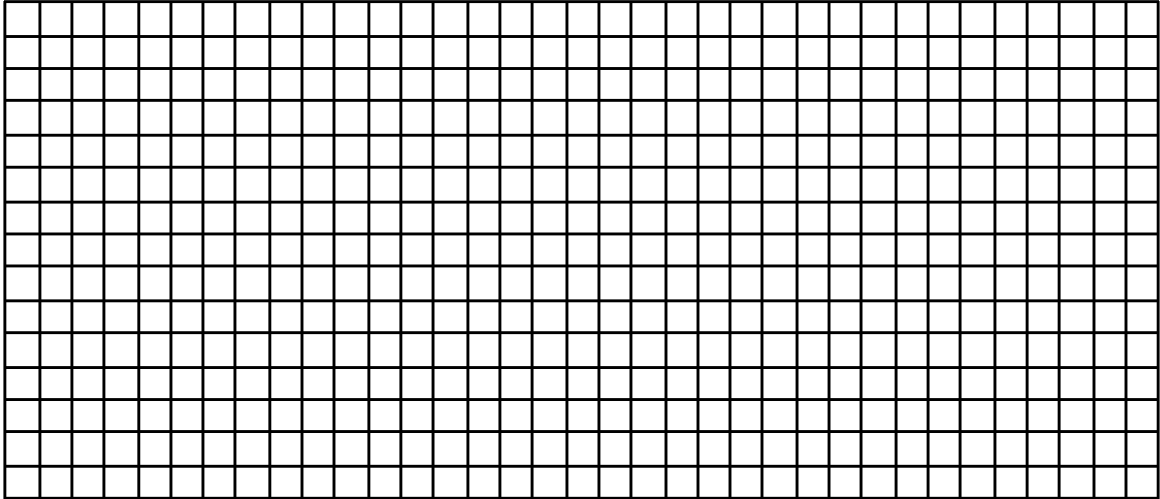

20766

**Profile 6**

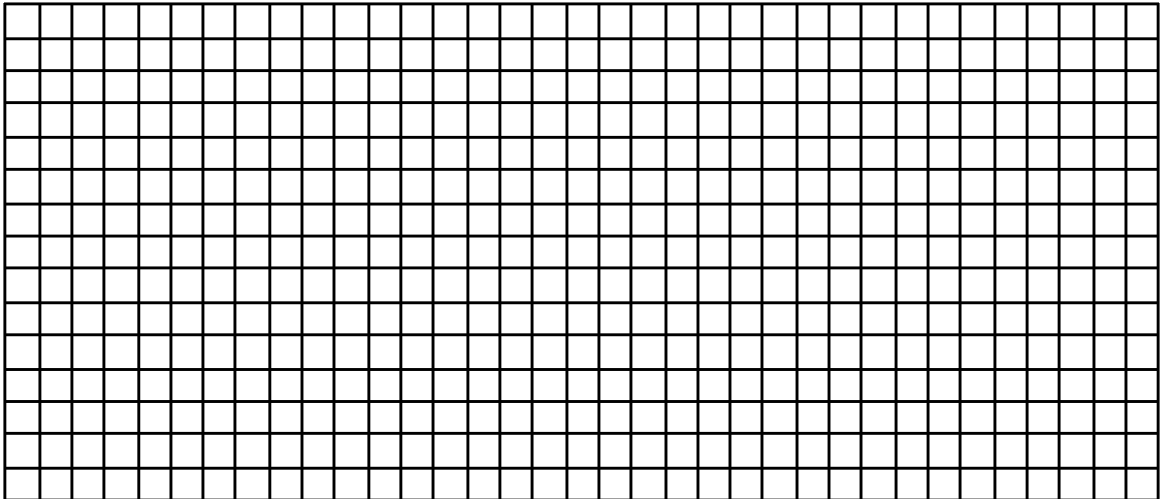

20766

## 6.4 Entering the Setpoint Program Data

### Introduction

The procedure listed in Table 6-2 tells you what keys to press and what prompts you will see when entering the setpoint program data. Follow the prompts in Subsections 6.5 through 6.8 when selecting the functions for setpoint programming.



#### ATTENTION

Make sure SP RAMP and SP RATE are disabled first.

**Table 6-2 Setpoint program data entry procedure**

Step	Operation	Press	Action/Result
1	Select SP PROG Group	<b>SET UP</b>	Until you see: <i>Upper Display: SET UP</i> <i>Lower Display: SP RAMP<sub>n</sub> n = 1 or 2</i>
2	Access SP PROG	<b>FUNC</b>	Until you see: <i>Upper Display: DISABL</i> <i>Lower Display: SP PROG</i>  If you see <i>Upper Display: ENABLE</i> <i>Lower Display: SP RAMP</i>  or <i>Upper Display: ENABLE</i> <i>Lower Display: SP RATE</i>  you must disable them. SP PROG and its subordinate prompts are not visible unless SP RAMP and SP RATE are disabled. Once they are disabled, press FUNC until you see SP PROG.
3	Enable SP PROG	<b>▲ or ▼</b>	Until you see: <i>Upper Display: ENABLE</i> <i>Lower Display: SP PROG</i>
4	Select the functions	<b>FUNC</b>	<i>Upper Display: shows current value for each prompt</i> <i>Lower Display: shows individual function prompts within the setpoint program group</i>  <ul style="list-style-type: none"> <li>• Successive presses of the <b>FUNCTION</b> key sequentially displays all the functions and their values or selections.</li> <li>• Using the <b>FUNCTION</b> key, follow the prompts shown in Sections 6.5 through 6.8.</li> </ul>

<b>Step</b>	<b>Operation</b>	<b>Press</b>	<b>Action/Result</b>
<b>5</b>	Change the value or selection of a function prompt	▲ or ▼	This changes the value or selection in the upper display. If the display blinks, you are trying to select an unacceptable value.
<b>6</b>	Enter value or selection into memory	<b>FUNC</b>	This enters the value or selection and goes to another prompt. <ul style="list-style-type: none"><li>• Repeat steps 4 and 5 for each function you want to change.</li></ul>
<b>7</b>	Exit configuration	<b>LOWR DISP</b>	This exits from the configuration mode.

## 6.5 SP RAMP1 and SP RAMP2 Set Up Group

### Introduction

There is a SP RAMP set up group for each control loop. Use the prompts to select the settings for each loop's program.

### SP RAMP prompts

Table 6-3 lists all the function prompts for SP RAMP configuration in the order of their appearance. These prompts are available when SPPROG is enabled in the SPRAMP set up group described in *Section 4*.

All parameters may be changed while the program is disabled or in HOLD.

**Table 6-3 SP RAMP prompts and available selections**

Lower Display Prompt	Upper Display Range of Setting or Selection	Parameter Definition
<b>SPPROG</b>	DISABL ENABLE	SETPOINT PROGRAMMING—This must be set to ENABLE for the setpoint program feature to work, and for the associated operating parameters to be displayed.  SPRAMP and SP RATE must be disabled. (See <i>Section 4</i> .)  DISABL—Disabled ENABLE—Enabled
<b>RECYCLES</b>	0 to 99	RECYCLES—Enter the number of times the program selected for execution will be repeated.
<b>SOAKDEV</b>	-99.9 to 99.9 engineering units	SOAK DEVIATION—Enter the acceptable deviation from setpoint during a soak cycle. If the PV differs from the setpoint by more than the value of SOAKDEV, soak time is frozen.  There are no guaranteed soaks if SOAKDEV = 0.
<b>PROFILE</b>	1 to 6	PROFILE used by Setpoint Program. This can also be set or changed when viewed in the lower display and the current profile is in the HOLD state.
<b>STATE</b>	DISABLE HOLD	Determines the state of the program after it completes the final program segment cycles. If you select DISABL, you must enable the program through the function prompt before you can run the program again. If you select HOLD, you can run the program again by pressing the <b>RUN/HOLD</b> key.
<b>RECOVERY</b>	ENABLE DISABL	This mode, when enabled, will allow the SP Program to continue from the point at which the power was removed when there is a power interruption.
<b>PROG END</b>	ENABLE DISABL	Determines the status of the control output after the program is run. If you select LASTSP, the recorder controls to the last setpoint value which becomes the LSP. For FSAFE selection, the recorder is switched to manual mode and to the selected failsafe output value.

### SP RAMP 1 and SP RAMP 2 worksheet

Use this worksheet to make a record of your SP RAMP1 and SP RAMP2 settings.

Prompt	Description	Range	Your selection
<b>SP RAMP1</b>	Accesses prompts for Control Loop 1's profile	N/A	N/A
<b>SP PROG</b>	Enables SP Program prompts.	ENABLE DISABLE	ENABLE
<b>RECYCLES</b>	Number of Recycles	0-99	
<b>SOAK DEV</b>	Deviation Value	0.0-99	
<b>PROFILE</b>	Number of profile to run	1-6	
<b>STATE</b>	Program State at end	DISABL HOLD	
<b>RECOVERY</b>	Program resumes after power interruption	ENABLE DISABLE	
<b>PROG END</b>	SP value after last segment	LASTSP FSAFE	
<b>SP RAMP2</b>	Accesses prompts for Control Loop 2's profile	N/A	N/A
<b>SP PROG</b>	Enables SP Program prompts.	ENABLE DISABLE	ENABLE
<b>RECYCLES</b>	Number of Recycles	0-99	
<b>SOAK DEV</b>	Deviation Value	0.0-99	
<b>PROFILE</b>	Number of profile to run	1-6	
<b>STATE</b>	Program State at end	DISABL HOLD	
<b>RECOVERY</b>	Program resumes after power interruption	ENABLE DISABLE	
<b>PROG END</b>	SP value after last segment	LASTSP FSAFE	



## 6.6 Setpoint Program Profiles Set Up Group

### Introduction

You can configure up to six profiles; each profile contains a subset of the 36 segments. Each profile starts with a ramp segment and ends with a soak segment. Each control loop uses one of these profiles. They can use the same profile, too. The profiles can be synchronized to RUN/HOLD together.

### Setpoint program profiles group prompts

Table 6-4 lists all the function prompts in the Setpoint Program Profiles setup group and their definitions.

**Table 6-4 Setpoint Program Profiles Group Definitions**

Lower Display Prompt	Upper Display Range of Setting or Selection	Parameter Definition
<b>PRx STRT</b>	RAMP1 – RAMP 35	You can configure up to 6 profiles (PR1 – PR6). Each profile contains a subset of the 36 ramp and soak segments configured later. PRx STRT designates the number of the first segment of the profile. It will be a ramp segment (odd number).
<b>PRx END</b>	SOAK2 – SOAK36	This designates the number of the last segment of the profile. It will be a soak segment (even number).
<b>RAMPUNIT</b>	TIME (Hours:Minutes) EU/MIN (Engineering Units/Minute) EU/HR (Engineering Units/Hour)	This determines the engineering units for the ramp segments.
<b>SYNC 1+2</b>	ENABLE DISABL	Synchronizes the profiles for Control Loops 1 and 2. This means that:  a) Both SP programs will RUN or HOLD simultaneously.  b) A Guaranteed Soak Hold on one profile will cause the other profile to HOLD for the duration of the Guaranteed Soak Hold.

### Setpoint program profiles worksheet

Use this worksheet to keep a record of your setpoint profile settings.

Prompt	Function	Range	Your selection
<b>PROFILES</b>	Settings for profiles		
<b>PR1 STRT</b>	Start Segment for Program 1	RAMP1 to RAMP35	
<b>PR1 END</b>	End Segment for Program 1	SOAK2 to SOAK36	
<b>PR2 STRT</b>	Start Segment for Program 2	RAMP1 to RAMP35	
<b>PR2 END</b>	End Segment for Program 2	SOAK2 to SOAK36	
<b>PR3 STRT</b>	Start Segment for Program 3	RAMP1 to RAMP35	
<b>PR3 END</b>	End Segment for Program 3	SOAK2 to SOAK36	
<b>PR4 STRT</b>	Start Segment for Program 4	RAMP1 to RAMP35	
<b>PR4 END</b>	End Segment for Program 4	SOAK2 to SOAK36	
<b>PR5 STRT</b>	Start Segment for Program 5	RAMP1 to RAMP35	
<b>PR5 END</b>	End Segment for Program 5	SOAK2 to SOAK36	
<b>PR6 STRT</b>	Start Segment for Program 6	RAMP1 to RAMP35	
<b>PR6 END</b>	End Segment for Program 6	SOAK2 to SOAK36	
<b>RAMPUNIT</b>	Ramp type	TIME EU/MIN EU/HR	
<b>SYNC 1+2</b>	Synchronizes profile for Control Loops 1 and 2.	ENABLE DISABL	

## 6.7 Setpoint Program Segments Set Up Group

### Introduction

You can configure up to 36 ramp and soak segments.

### Setpoint program segments group prompts

Table 6-5 lists all the function prompts in the Setpoint Program Segments setup group and their definitions.

**Table 6-5 Setpoint Program Segments Group Definitions**

Lower Display Prompt	Upper Display Range of Setting or Selection	Parameter Definition
<b>SEGxRAMP</b> (x = 1, 3, 5,...35)	0-99 hrs:59 min. (Time) 0 to 999 (Rate)	A ramp segment is the time it takes to change the setpoint to the next setpoint value in the program. <ul style="list-style-type: none"> <li>Ramps are odd number segments. Segment #1 will be the initial ramp time.</li> <li>This selection of time or rate is made at prompt "RAMPUNIT".</li> </ul> <p>ATTENTION: Entering "0" implies an immediate step change in setpoint to the next soak.</p>
<b>SEGx SP</b> (x = 2, 4, 6...36)	Within the setpoint high and low range limits in engineering units	The soak segment's setpoint value
<b>SEGxTIME</b> (x = 2, 4, 6...36)	0-99 hrs:59 min.	The soak segment's duration.

### Setpoint program segments worksheet

Use this worksheet to keep a record of your setpoint segment settings.

Prompt	Function	Range	Your Selection	Prompt	Function	Range	Your Selection
SPP SEGS	Settings for segments			SG15RAMP	Ramp	00 to 99.59	
SEG1RAMP	Start Seg Prog 1	RAMP1 to RAMP35		SG16 SP	Soak SP	Within SP limits	
SEG2 SP	End Seg Prog 1	SOAK2 to SOAK36		SG16TIME	Soak Time	00.00 to 99.59	
SEG2 TIME	Start Seg Prog 2	RAMP1 to RAMP35		SG17RAMP	Ramp	00 to 99.59	
SEG3 RAMP	Ramp	00 to 99.59		SG18 SP	Soak SP	Within SP limits	
SEG4 SP	Soak SP	Within SP limits		SG18TIME	Soak Time	00.00 to 99.59	
SEG4TIME	Soak Time	00.00 to 99.59		SG19RAMP	Ramp	00 to 99.59	
SEG5 RAMP	Ramp	00 to 99.59		SG20 SP	Soak SP	Within SP limits	
SEG6 SP	Soak SP	Within SP limits		SG20TIME	Soak Time	00.00 to 99.59	
SEG6TIME	Soak Time	00.00 to 99.59		SG21RAMP	Ramp	00 to 99.59	
SEG7 RAMP	Ramp	00 to 99.59		SG22 SP	Soak SP	Within SP limits	
SEG8 SP	Soak SP	Within SP limits		SG22TIME	Soak Time	00.00 to 99.59	
SEG8TIME	Soak Time	00.00 to 99.59		SG23RAMP	Ramp	00 to 99.59	
SEG9RAMP	Ramp	00 to 99.59		SG24 SP	Soak SP	Within SP limits	
SG10 SP	Soak SP	Within SP limits		SG24TIME	Soak Time	00.00 to 99.59	
SG10TIME	Soak Time	00.00 to 99.59		SG25RAMP	Ramp	00 to 99.59	
SG11RAMP	Ramp	00 to 99.59		SG26 SP	Soak SP	Within SP limits	
SG12 SP	Soak SP	Within SP limits		SG26TIME	Soak Time	00.00 to 99.59	
SG12TIME	Soak Time	00.00 to 99.59		SG27RAMP	Ramp	00.00 to 99.59	
SG13RAMP	Ramp	00 to 99.59		SG28 SP	Soak SP	Within SP limits	
SG14 SP	Soak SP	Within SP limits		SG28TIME	Soak Time	00.00 to 99.59	
SG14TIME	Soak Time	00.00 to 99.59		SG29RAMP	Ramp	00.00 to 99.59	

Prompt	Function	Range	Your Selection
<b>SG30 SP</b>	Soak SP	Within SP limits	
<b>SG30TIME</b>	Soak Time	00.00 to 99.59	
<b>SG31RAMP</b>	Ramp	00.00 to 99.59	
<b>SG32 SP</b>	Soak SP	Within SP limits	
<b>SG32TIME</b>	Soak Time	00.00 to 99.59	
<b>SG33RAMP</b>	Ramp	00.00 to 99.59	

Prompt	Function	Range	Your Selection
<b>SG34 SP</b>	Soak SP	Within SP limits	
<b>SG34TIME</b>	Soak Time	00.00 to 99.59	
<b>SG35RAMP</b>	Ramp	00.00 to 99.59	
<b>SG36 SP</b>	Soak SP	Within SP limits	
<b>SG36TIME</b>	Soak Time	00.00 to 99.59	

## 6.8 Setpoint Program Event Set Up Group

### Introduction

Segment events are used to activate relays by means of alarms. There are six alarms and six corresponding relays. Alarm 1 controls Relay 1, Alarm 2 controls Relay 2, etc. When the setpoint program reaches the segment, the segment event triggers the alarm which triggers the relay. The relay stays on for the duration of the segment. There are no alarm conditions to be satisfied, that is, when the event goes on the alarm goes on.

### How to trigger a relay with a segment event

1. Program the segment event with the alarm corresponding with the desired relay.
2. Program that alarm as type EVENT. It is not necessary to program any alarm parameters other than the alarm type.
3. Do not program other functions that have higher priority control of the relay. See Table 6-7.

### Setpoint Program Event group prompts

Table 6-6 lists all the function prompts in the Setpoint Program Event setup group and their definitions.

**Table 6-6 Setpoint Program Event Group Definitions**

Lower Display Prompt	Upper Display Range of Setting or Selection	Parameter Definition
<b>SEGx EV</b> (x = 1-36)	NONE ALARM1, ALARM2, ALARM3, ALARM4, ALARM5, ALARM6	Configured event will be active during the segment. All others will be inactive.

### Example of how a segment event works

For example, to have Segment 1 energize Relay 1:

- Program SEG1 EV as ALARM1.
- Program A1S1TYPE or A1S2TYPE as EVENT.
- Do not program the Timer function Relay 1; namely, Timer.

For alarm programming information, see *Subsection 4.12*.

**To ensure control of relay by segment event**

To make sure a segment event operates the associated relay, observe the requirements below.

**Table 6-7 Segment Event relay operation requirements**

<b>Relay</b>	<b>Relay is controlled by (in order of priority)</b>	<b>Requirements for operation of relay by segment event</b>
<b>1</b>	<ol style="list-style-type: none"> <li>1. Timer function</li> <li>2. Alarm 1</li> </ol>	<ul style="list-style-type: none"> <li>• Do not configure Timer.</li> <li>• Configure Alarm 1 type Event.</li> </ul>
<b>2</b>	Alarm 2	Configure Alarm 2 type Event.
<b>3</b>	<ol style="list-style-type: none"> <li>1. Controller 1 output algorithms Relay Simplex, Position Proportional, Relay Duplex, Current/Relay Duplex</li> <li>2. Alarm 3</li> </ol>	<ul style="list-style-type: none"> <li>• Do not configure Controller #1 with these output algorithms.</li> <li>• Configure Alarm 3 type Event.</li> </ul>
<b>4</b>	<ol style="list-style-type: none"> <li>1. Controller 1 output algorithms Position Proportional, Relay Duplex, Current/Relay Duplex</li> <li>2. Alarm 4</li> </ol>	<ul style="list-style-type: none"> <li>• Do not configure Controller #1 with these output algorithms.</li> <li>• Configure Alarm 4 type Event.</li> </ul>
<b>5</b>	<ol style="list-style-type: none"> <li>1. Controller 2 output algorithms Relay Simplex, Position Proportional, Relay Duplex, Current/Relay Duplex</li> <li>2. Alarm 5</li> </ol>	<ul style="list-style-type: none"> <li>• Do not configure Controller #2 with these output algorithms.</li> <li>• Configure Alarm 5 type Event.</li> </ul>
<b>6</b>	<ol style="list-style-type: none"> <li>1. Controller 2 output algorithms Position Proportional, Relay Duplex, Current/Relay Duplex</li> <li>2. Alarm 6</li> </ol>	<ul style="list-style-type: none"> <li>• Do not configure Controller #2 with these output algorithms.</li> <li>• Configure Alarm 6 type Event.</li> </ul>

### Setpoint program events worksheet

Use this worksheet to make a record of the segment event settings.

Prompt	Description	Range	Your selection
<b>SPP EVNT</b>	Access to events	N/A	N/A
<b>SEG1 EV</b>	Event status	NONE ALARM1 ALARM2 ALARM3 ALARM4 ALARM5 ALARM6	
<b>SEG2 EV</b>	Event status	Same	
<b>SEG3 EV</b>	Event status	Same	
<b>SEG4 EV</b>	Event status	Same	
<b>SEG5 EV</b>	Event status	Same	
<b>SEG6 EV</b>	Event status	Same	
<b>SEG7 EV</b>	Event status	Same	
<b>SEG8 EV</b>	Event status	Same	
<b>SEG9 EV</b>	Event status	Same	
<b>SEG10 EV</b>	Event status	Same	
<b>SEG11 EV</b>	Event status	Same	
<b>SEG12 EV</b>	Event status	Same	
<b>SEG13 EV</b>	Event status	Same	
<b>SEG14 EV</b>	Event status	Same	
<b>SEG15 EV</b>	Event status	Same	
<b>SEG16 EV</b>	Event status	Same	
<b>SEG17 EV</b>	Event status	Same	
<b>SEG18 EV</b>	Event status	Same	
<b>SEG19 EV</b>	Event status	Same	
<b>SEG20 EV</b>	Event status	Same	
<b>SEG21 EV</b>	Event status	Same	
<b>SEG22 EV</b>	Event status	Same	
<b>SEG23 EV</b>	Event status	Same	
<b>SEG24 EV</b>	Event status	Same	
<b>SEG25 EV</b>	Event status	Same	
<b>SEG26 EV</b>	Event status	Same	



Prompt	Description	Range	Your selection
<b>SEG27 EV</b>	Event status	Same	
<b>SEG28 EV</b>	Event status	Same	
<b>SEG29 EV</b>	Event status	Same	
<b>SEG30 EV</b>	Event status	Same	
<b>SEG31 EV</b>	Event status	Same	
<b>SEG32 EV</b>	Event status	Same	
<b>SEG33 EV</b>	Event status	Same	
<b>SEG34 EV</b>	Event status	Same	
<b>SEG35 EV</b>	Event status	Same	
<b>SEG36 EV</b>	Event status	Same	

## 6.9 Run/Monitor the Program

### Introduction

Make sure all the “SP PROG” function prompts under the Set Up group “SP RAMP” have been configured with the required data.

- An “H” appears in the upper display indicating that the program is in the HOLD state. If an “H” doesn’t appear, go to the SP Program configuration procedure and enable the program instead of disabling.



#### ATTENTION

For recorders with two controllers (both enabled), remember that any controller-related values displayed correspond with the lighted CHN indicator. “1” means that the values apply for Controller #1 and “2” means that the values apply for Controller #2.

### Run/Monitor functions

Table 6-8 lists all the functions required to run and monitor the program.

**Table 6-8 Run/Monitor Functions**

Function	Press	Result
<b>Run State</b>	<b>RUN HOLD</b>	Initiates the setpoint program. “H” changes to “R” in the upper display indicating that the program is running. PV value and pen trace tracks the ramp soak profile.
<b>Hold State</b>	<b>RUN HOLD</b>	Holds the setpoint program. <ul style="list-style-type: none"> <li>• An “H” appears in the upper display indicating that the program is in the HOLD state.</li> <li>• The setpoint holds at the current setpoint. Press again to continue to run.</li> </ul>
<b>External Hold</b>		If Remote Switching (Digital Input Option) is present on your recorder, contact closure places the recorder in the HOLD state, if the setpoint program is running. <ul style="list-style-type: none"> <li>• The “H” in the upper display blinks.</li> </ul> <div style="border: 1px solid black; padding: 2px; display: inline-block;"><b>ATTENTION</b></div> The keyboard takes priority over external switch for the RUN/HOLD function. <ul style="list-style-type: none"> <li>• Contact reopening runs program.</li> </ul>

Function	Press	Result																											
Viewing the present ramp or soak segment number and time	LOWR DISP	<p>Until you see:</p> <p><i>Upper Display:</i> <b>R</b> and the PV value</p> <p><i>Lower Display:</i></p> <p>For Ramp segments:</p> <p><b># RA XX.XX</b></p> <table border="0"> <tr> <td> </td> <td> </td> <td>Ramp Time - Hours:Minutes or</td> </tr> <tr> <td> </td> <td> </td> <td>Ramp Rate - Degrees/Minute</td> </tr> <tr> <td> </td> <td> </td> <td>Indicates Ramp segment</td> </tr> <tr> <td> </td> <td> </td> <td>Segment Number (odd only)</td> </tr> </table> <p>For Soak segments:</p> <p><b># SK XX.XX</b></p> <table border="0"> <tr> <td> </td> <td> </td> <td>Time remaining in segment in</td> </tr> <tr> <td> </td> <td> </td> <td>Hrs:Minutes including current</td> </tr> <tr> <td> </td> <td> </td> <td>partially completed minute</td> </tr> <tr> <td> </td> <td> </td> <td>Indicates Soak segment</td> </tr> <tr> <td> </td> <td> </td> <td>Segment Number (even only)</td> </tr> </table>			Ramp Time - Hours:Minutes or			Ramp Rate - Degrees/Minute			Indicates Ramp segment			Segment Number (odd only)			Time remaining in segment in			Hrs:Minutes including current			partially completed minute			Indicates Soak segment			Segment Number (even only)
		Ramp Time - Hours:Minutes or																											
		Ramp Rate - Degrees/Minute																											
		Indicates Ramp segment																											
		Segment Number (odd only)																											
		Time remaining in segment in																											
		Hrs:Minutes including current																											
		partially completed minute																											
		Indicates Soak segment																											
		Segment Number (even only)																											
Skipping segments	LOWR DISP	<p>Until you see:</p> <p><i>Upper Display:</i> <b>R</b> and the PV value</p> <p><i>Lower Display:</i> <b>#RA XX.XX</b> (Ramp Segment) <b>#SK XX.XX</b> (Soak Segment)</p>																											
	RUN HOLD	<p>To hold the SP Program</p> <ul style="list-style-type: none"> <li>An “H” appears in the upper display indicating that the program is in the HOLD state.</li> </ul>																											
	▲ or ▼	To select new segment																											
	RUN HOLD or LOWR DISP	<p>To begin running at new segment</p> <p>To retain the old segment</p>																											
Viewing the number of cycles left in the program	LOWER DISP	<p>Until you see:</p> <p><i>Upper Display:</i> <b>R</b> and the PV value</p> <p><i>Lower Display:</i> <b>RECYC XX</b> Remaining cycles 0 to 99 This number includes the current partially completed cycle.</p>																											
End Program		<p>When the final segment is completed, the “R” in the upper display either changes to “H” if configured for HOLD state, or disappears if configured for DISABL of setpoint programming.</p> <ul style="list-style-type: none"> <li>The recorder operates at the last setpoint in the program in automatic or will be in manual mode at the failsafe output.</li> </ul>																											



# 7. Input Calibration

## 7.1 Overview



### SHOCK HAZARD – WARNING!

**Disregard of these instructions may cause injury or death.**

INPUT CALIBRATION MAY REQUIRE ACCESS TO HAZARDOUS LIVE CIRCUITS, AND SHOULD ONLY BE PERFORMED BY QUALIFIED SERVICE PERSONNEL. MORE THAN ONE SWITCH MAY BE REQUIRED TO DE-ENERGIZE UNIT BEFORE CALIBRATION.

### Introduction

This section describes the field calibration procedures for inputs 1, 2, 3, and 4. All DR4500A recorders are factory calibrated prior to shipment. It should not, therefore, be necessary to recalibrate the recorder when it is initially installed. However, you must recalibrate the input if any one of the conditions summarized below applies:

- The thermocouple or RTD input must meet published\* accuracy rates. Note that the factory calibration at reference is  $\pm 1.2$  °F plus  $\pm 10$  microvolts for thermocouples or  $\pm 0.3$  ohms for RTDs.  
\* Specifications 44-45-03-14
- You are using a 0-10 Vdc input. Recalibration is necessary because the resistor network used for this input has a tolerance of  $\pm 1.0$  %.
- You have cause to believe that the recorder is out of calibration.
- You must perform regularly scheduled or periodic recalibration based on your own needs.
- You have performed specific servicing activities such as replacement of an input PCB.



### ATTENTION

Replacing a main PCB does not normally require recalibration since a new main PCB is already factory calibrated, whereas an input PCB is not.

- You have changed the input type through configuration which results in the loss of the previous field calibration, but restores factory calibration. See *Subsection 7.2 Restoring Factory Calibration* paragraph that follows.

### What's in this section?

This section contains the following topics:

	Topic	See Page
7.1	Overview	199
7.2	Restoring Factory Calibration	200
7.3	Minimum and Maximum Range Values	202
7.4	Preliminary Information	203
7.5	Calibration Set Up and Wiring for PV Inputs	205
7.6	Calibration Procedure	214
7.7	Printing Characteristics Adjustments	217

## 7.2 Restoring Factory Calibration

### How to restore it

The factory calibration constants for all the input actuation types that can be used with the DR4500A recorder are stored in its nonvolatile memory. Thus, you can quickly restore the “Factory Calibration” for a given input actuation type by simply configuring the actuation type through the IN1 TYPE (or IN2 TYPE, IN3 TYPE, IN4 TYPE) prompt to another type and then changing it back to the original type. See Table 7-1 for the procedure.



#### ATTENTION

This procedure applies only for factory-installed inputs. Any input that was field-installed must be field calibrated.

### Procedure

Table 7-1 lists the procedure for restoring factory calibration.

**Table 7-1 Restoring Factory Calibration**

Step	Operation	Press	Action/Result
1	Enter Input Setup Group	<b>SET UP</b>	Until you see: <i>Upper Display: SET UP</i> <i>Lower Display: INPUT n</i> n = 1, 2, 3, or 4
2	Change input type	<b>FUNC</b>	Until you see: <i>Upper Display:</i> Note the input type in the upper display. Make sure that the selection matches the type of sensor that is connected to the input in your application. Write it down, if necessary. <i>Lower Display: INn TYPE</i> n = 1, 2, 3, or 4
		▲ or ▼	Until you see: <i>Upper Display: 0-10V</i> <i>Lower Display: INn TYPE</i> <b>ATTENTION</b> If you are already using a 0-10V input, change to a 0-5V input type.
		<b>FUNC</b>	Until the upper display rolls through the input types and returns to <i>Upper Display: 0-10V</i> <i>Lower Display: INn TYPE</i>

Step	Operation	Press	Action/Result
		▲ or ▼	Until you change the input selection in the upper display back to the proper selection. You will see:  <i>Upper Display:</i> Original input selection that matches your type of sensor.  <i>Lower Display:</i> <b>INn TYPE</b>
<b>3</b>	Return to normal operating mode	<b>LOWR DISP</b>	To return to Normal operating mode.  The factory calibration will be restored. If the problem is not corrected, contact the Honeywell Technical Assistance Center.  1-800-423-9883 USA and Canada



**CAUTION**

A restored factory calibration overwrites any previous field calibration done for the input. Be sure to protect any field calibration from accidental overwrites by configuring the appropriate "LOCKOUT" selection after calibration. See the *Section 3 - Configuration* for specific instructions to set the lockout.

---

## 7.3 Minimum and Maximum Range Values

### Select the range values

You should calibrate the recorder for the minimum (0 %) and maximum (100 %) range values of your particular sensor.

- If your recorder has two or more inputs, calibrate each input separately. Select the voltage or resistance equivalent for 0 % and 100 % range values from Table 7-2, use these values when calibrating your recorder.

**Table 7-2 Voltage and Resistance Equivalents for 0 % and 100 % Range Values**

Sensor Type	PV Input Range		Range Values*		
	°F	°C	0 %	68 °F/20 °C	100 %
<b>Thermocouples</b>					
<b>B</b>	105 to 3300	41 to 1816	0 mV	0.003 mV	13.763 mV
<b>E</b>	-454 to 1832	-270 to 1000	-9.835 mV	1.192 mV	76.358 mV
<b>E (low)</b>	-200 to 1100	-129 to 593	-6.471 mV		44.547 mV
<b>J</b>	0 to 1600	-18 to 871	-0.885 mV	1.019 mV	50.059 mV
<b>J (low)</b>	20 to 770	-7 to 410	-0.334 mV		22.397 mV
<b>K</b>	-320 to 2500	-196 to 1371	-5.822 mV	0.798 mV	54.845 mV
<b>K (low)</b>	-20 to 1000	-29 to 538	-1.114 mV		22.251 mV
<b>NiNiMoly</b>	32 to 2500	0 to 1371	-0.001 mV	1.458 mV	71.330 mV
<b>NIC Nicrosil Nisil</b>	0 to 2372	-17.8 to 1300	-0.461 mV	0.525 mV	47.502 mV
<b>R</b>	0 to 3100	-18 to 1704	-0.089 mV	0.111 mV	20.275 mV
<b>S</b>	0 to 3100	-18 to 1704	-0.092 mV	0.113 mV	17.993 mV
<b>T</b>	-300 to 700	-184 to 371	-5.341 mV	0.789 mV	19.095 mV
<b>T (low)</b>	-200 to 600	-129 to 316	-4.149 mV		15.769 mV
<b>W5W26</b>	0 to 4200	-18 to 2315	-0.234 mV	0.062 mV	37.066 mV
<b>W5W26 (low)</b>	0 to 2240	-18 to 1227	-0.234 mV		22.277 mV
<b>RTD***</b>					
<b>100 Ω</b>	-300 to 900	-184 to 482	25.18 Ω		274.96 Ω
<b>100 Ω (RH)</b>	-130 to 392	-90 to 200	64.30 Ω		175.84 Ω
<b>200 Ω</b>	32 to 752	0 to 400	200 Ω		498.10 Ω
<b>200 Ω</b>	32 to 392	0 to 200	200 Ω		353.74 Ω
<b>500 Ω</b>	-300 to 900	-184 to 482	125.90 Ω		1374.80 Ω
<b>Milliamps</b>	4 to 20 mA		4 mA		20 mA
<b>Millivolts</b>	0 to 10 mV		0 mV		10 mV
	10 to 50 mV		10 mV		50 mV
<b>Volts</b>	0 to 5 Volts		0 Volts		5 Volts
	0 to 10 Volts**		0 Vols		10 Volts
<b>Radiamatic (RH)</b>	1400 to 3400	760 to 1871	0.99 mV		57.12 mV

\*Range values for thermocouples are based on a cold junction temperature of 32 °F (0 °C). These values must be adjusted for the actual cold junction temperature when using the ambient temperature method for calibrating thermocouple inputs.

\*\*Resistor network 30755232-002 must be installed in inputs #1, #2, #3, and #4 when using this range, see set up diagram for details.

\*\*\*IEC = .00385—100 Ω

IEC = .003902—200 Ω



## 7.4 Preliminary Information

### Disconnect the field wiring

Depending on which input (#1, #2, #3, or #4) you are going to calibrate, tag and disconnect any field wiring connected to the input terminals on the input boards inside the recorder. Reference Figure 7-1 and follow the procedure in Table 7-3.

**Table 7-3 Disconnect the Field Wiring**

Step	Action
1	Remove the operating power from the recorder.
2	Open the door on the recorder.
3	Loosen the phillips screw on the right side of the chart plate, and open the chart plate.
4	Depending on the input (1, 2, 3, or 4) you are going to calibrate, remove the wired plug from the input connector (J2) on the applicable circuit board. See Figure 7-1 for the location of the circuit boards and input connectors.
5	Tag and disconnect the field wiring installed in the applicable input connector plug.

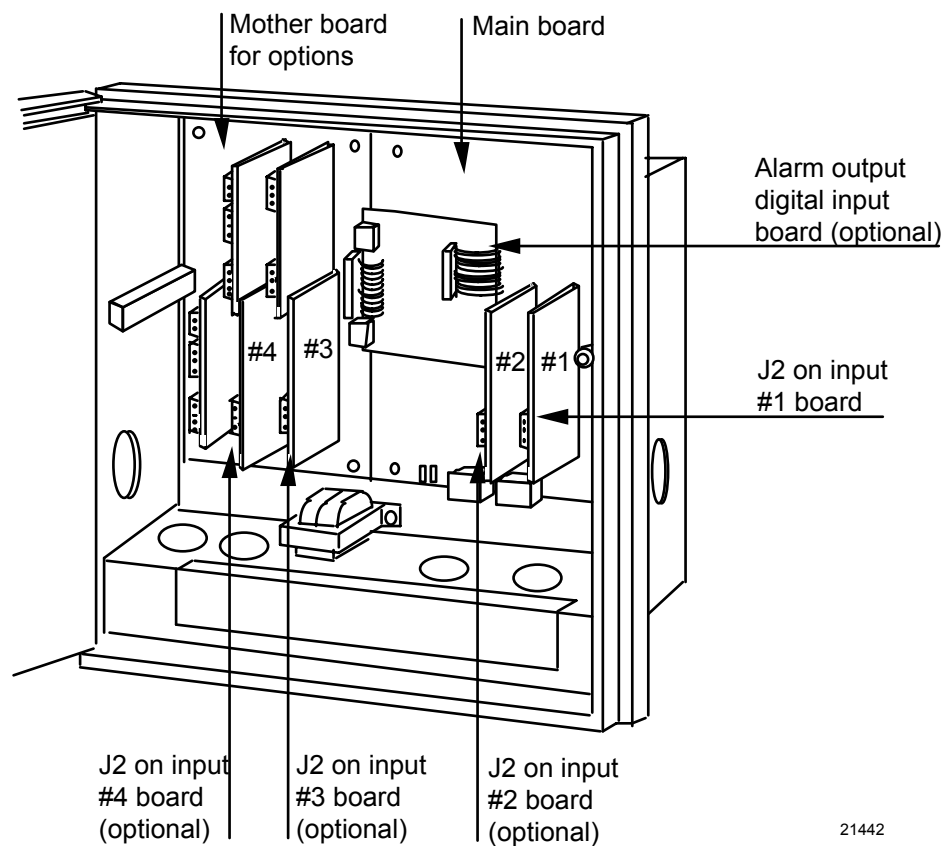

**Figure 7-1 Location of the Input Connections on the Input Boards**

### Equipment needed

Table 7-4 lists the equipment required to calibrate the specific types of inputs listed in the table. You will need a medium size bladed screwdriver for general use and a small size bladed screwdriver for use with the screws on the connector plugs.

**Table 7-4 Equipment Needed**

Type of Input	Equipment Needed
<i>Thermocouple Inputs (Ice Bath)</i>	<ul style="list-style-type: none"> <li>• A calibrating device with <math>\pm 0.02</math> % accuracy for use as a signal source such as a millivolt source.</li> <li>• Thermocouple extension wire that corresponds with the type of thermocouple that will be used with the recorder input.</li> <li>• Two insulated copper leads for connecting the thermocouple extension wire from the ice baths to the precision calibrator.</li> <li>• Two containers of crushed ice.</li> </ul>
<i>Thermocouple Inputs (Ambient Temperature)</i>	<ul style="list-style-type: none"> <li>• A calibrating device with <math>\pm 0.02</math> % accuracy for use as a signal source such as a millivolt source.</li> <li>• Two insulated copper leads for connecting the calibrator to the controller.</li> </ul>
<i>Thermocouple Inputs (Compensated Calibrator)</i>	<ul style="list-style-type: none"> <li>• A calibrating device with temperature compensation and <math>\pm 0.02</math> % accuracy for use as a signal source.</li> <li>• Thermocouple extension wire that corresponds with the type of thermocouple that will be used with the recorder input.</li> </ul>
<i>RTD (Resistance Thermometer Device)</i>	<ul style="list-style-type: none"> <li>• A resistance decade box, with <math>\pm 0.02</math> % accuracy, capable of providing stepped resistance values over a minimum range of 0 to 1400 ohms with a resolution of 0.01 ohm.</li> <li>• Three insulated copper leads for connecting the decade box to the controller.</li> </ul>
<i>Radiomatic, Milliampere, Millivolt, and Volts Inputs</i>	<ul style="list-style-type: none"> <li>• A calibrating device with <math>\pm 0.02</math> % accuracy for use as a signal source.</li> <li>• Two insulated copper leads for connecting the calibrator to the controller.</li> </ul>

## 7.5 Calibration Set Up and Wiring for PV Inputs

### Jumper positions

Before starting the calibration activity, check that the jumper plugs on the applicable input circuit board are installed in the proper jumper position (in W1/MA and W3) for the particular sensor being used (refer to the wiring connection drawings in this section for each individual setting).

Refer to Figure 7-2 for the location of jumper positions W1/MA and W3 on these circuit boards, and the status of these jumpers for each type of input sensor.

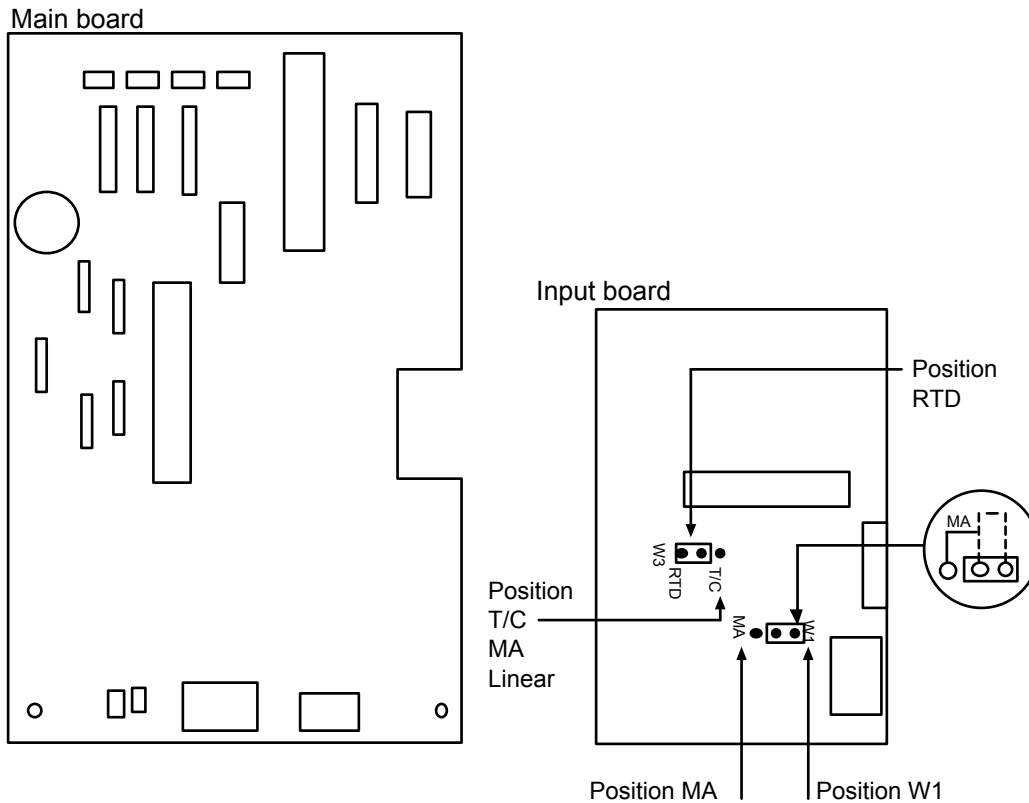

### Status of jumper plugs

1. Install W1/MA plug in position W1 for thermocouple, RTD, Radiamatic, mV, 0-5 Vdc, 0-10 Vdc inputs.
2. Install W1/MA plug in position MA for 4-20 mA inputs.
3. Install plug in W3 according to your input type.

21443

**Figure 7-2 Location of Jumper Positions W1/MA and W3 on the Input Boards**

### Thermocouple input calibration methods

You can calibrate for a thermocouple input using one of three methods:

- using an ice bath,
- using a compensated calibrator, or
- by measuring the ambient temperature at the input terminals and subtracting the voltage contribution of the input terminal junction.

### General set up procedure

Table 7-5 lists the general set up procedure for all methods of calibration. Do this procedure and then refer to the set up procedure and diagram for your specific input.

**Table 7-5 General Set Up Procedure**

Step	Action
<b>1</b>	Set up and connect the calibrator to the input plug for the applicable input circuit board in your recorder according to the particular input sensor being used. Refer to the following figures for corresponding set-up diagrams: <ul style="list-style-type: none"><li>• Figure 7-3 Thermocouple inputs using an ice bath</li><li>• Figure 7-4 Thermocouple inputs using a compensated calibrator</li><li>• Figure 7-5 Thermocouple inputs using the ambient temperature method</li><li>• Figure 7-6 RTD (Resistance Thermometer Device) inputs</li><li>• Figure 7-7 Radiamatic, mV and Volts (except 0–10 Volts) inputs</li><li>• Figure 7-8 0-10 Volts input</li><li>• Figure 7-9 4–20 mA inputs</li></ul>
<b>2</b>	Route leads (for example: copper leads or thermocouple extension wires) through a conduit hole in the recorder case so that you will be able to close the chart plate.
<b>3</b>	Close the chart plate after you have completed the applicable calibration set up.

**Thermocouple inputs using an ice bath**

Refer to Figure 7-3 and wire the recorder according to the procedure given in Table 7-6.

**Table 7-6 Set Up Wiring Procedure for Thermocouple Inputs Using an Ice Bath**

Step	Action
1	Connect the copper leads to the calibration source (see Figure 7-3).
2	Connect a length of thermocouple extension wire to the end of each copper lead and insert the junction points into the ice bath.
3	Connect the other end of the thermocouple extension wires to the clamp type terminals in the plug for the applicable input connector (J2).
4	Reinstall the plug into the input connector (J2) on the applicable circuit board for Input 1, Input 2, Input 3, or Input 4.

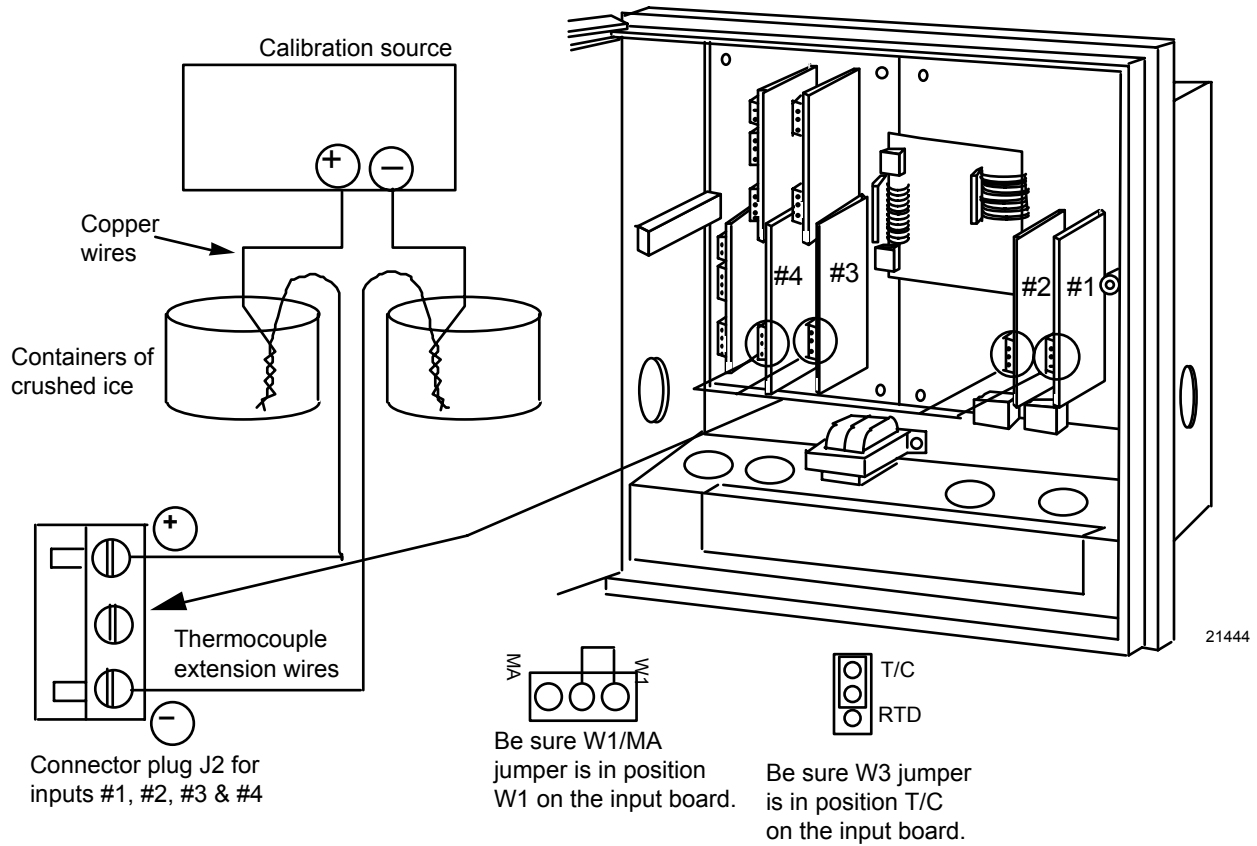

**Figure 7-3 Calibration Set Up Diagram for Thermocouple Inputs Using an Ice Bath**

**Thermocouple inputs using a compensated calibrator method**

Refer to Figure 7-4 and wire the recorder according to the procedure given in Table 7-7.

**Table 7-7 Set Up Wiring Procedure for Thermocouple Inputs Using a Compensated Calibrator Method**

Step	Action
1	Connect the thermocouple extension wire to the Precision Compensated Calibrator (see Figure 7-4).
2	Connect the other end of the thermocouple extension wires to the clamp type terminals in the plug for the applicable input connector (J2).
3	Reinstall the plug into the input connector (J2) on the applicable circuit board for Input 1, Input 2, Input 3, or Input 4.

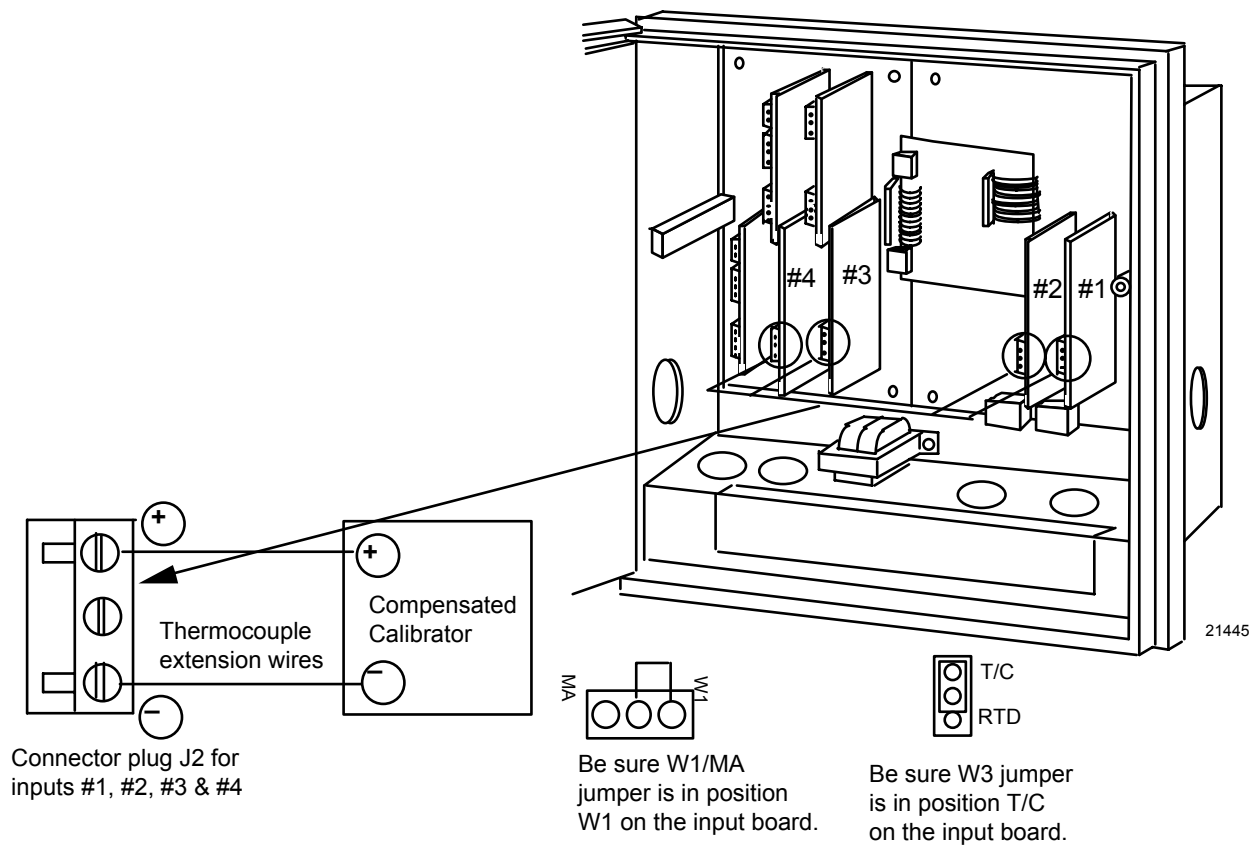

**Figure 7-4 Calibration Set Up Diagram for Thermocouple Inputs Using a Compensated Calibrator Method**

**Thermocouple inputs using the ambient temperature method**

Refer to Figure 7-5 and wire the recorder according to the procedure given in Table 7-8.

**Table 7-8 Set Up Wiring Procedure for Thermocouple Inputs Using the Ambient Temperature Method**

Step	Action
1	Connect the copper wire to the Precision Millivolt Source (see Figure 7-5).
2	Connect the other end of the copper wire to the clamp type terminals in the plug for the applicable input connector (J2).
3	Reinstall the plug into the input connector (J2) on the applicable circuit board for input 1, input 2, input 3, or input 4.

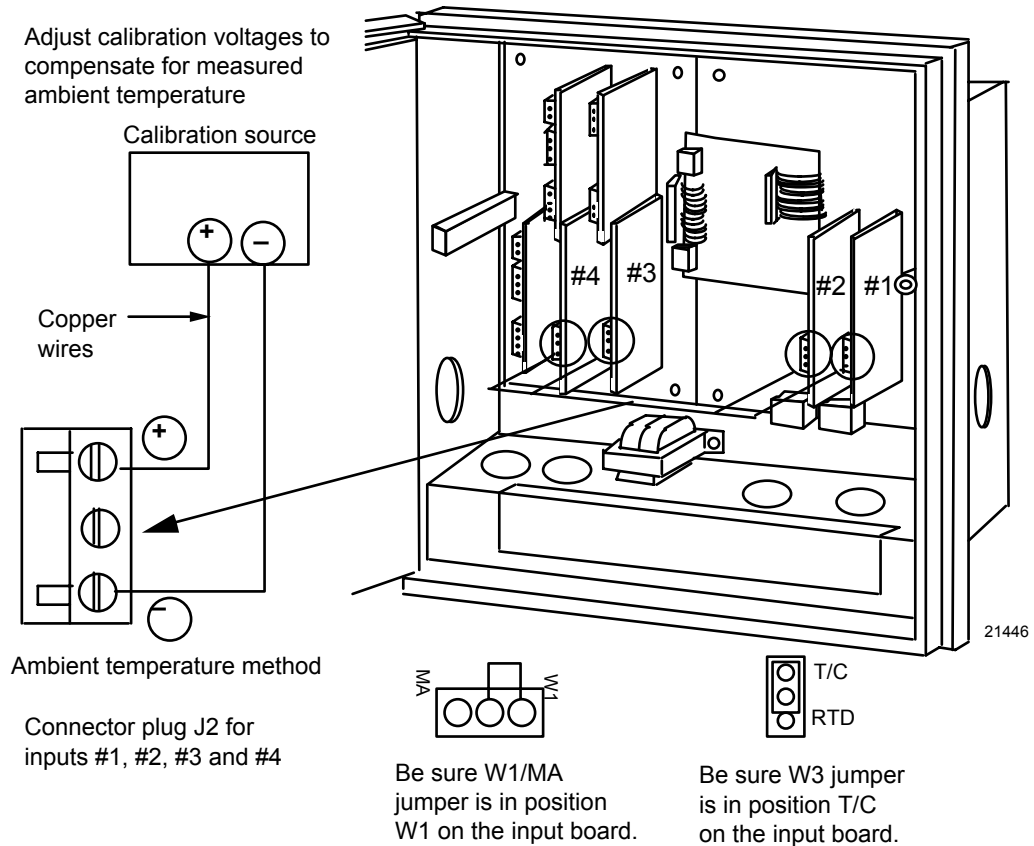

**Figure 7-5 Calibration Set Up Diagram for Thermocouple Inputs using the Ambient Temperature Method**

**RTD (Resistance Thermometer Device) inputs**

Refer to Figure 7-6 and wire the recorder according to the procedure given in Table 7-9.

**Table 7-9 Set Up Wiring Procedure for RTD Inputs**

Step	Action
1	Connect the copper wire to the calibration source (see Figure 7-6).
2	Connect the other end of the copper wire to the clamp type terminals in the plug for the applicable input connector (J2).
3	Reinstall the plug into the input connector (J2) on the applicable circuit board for input 1, input 2, input 3, or input 4.

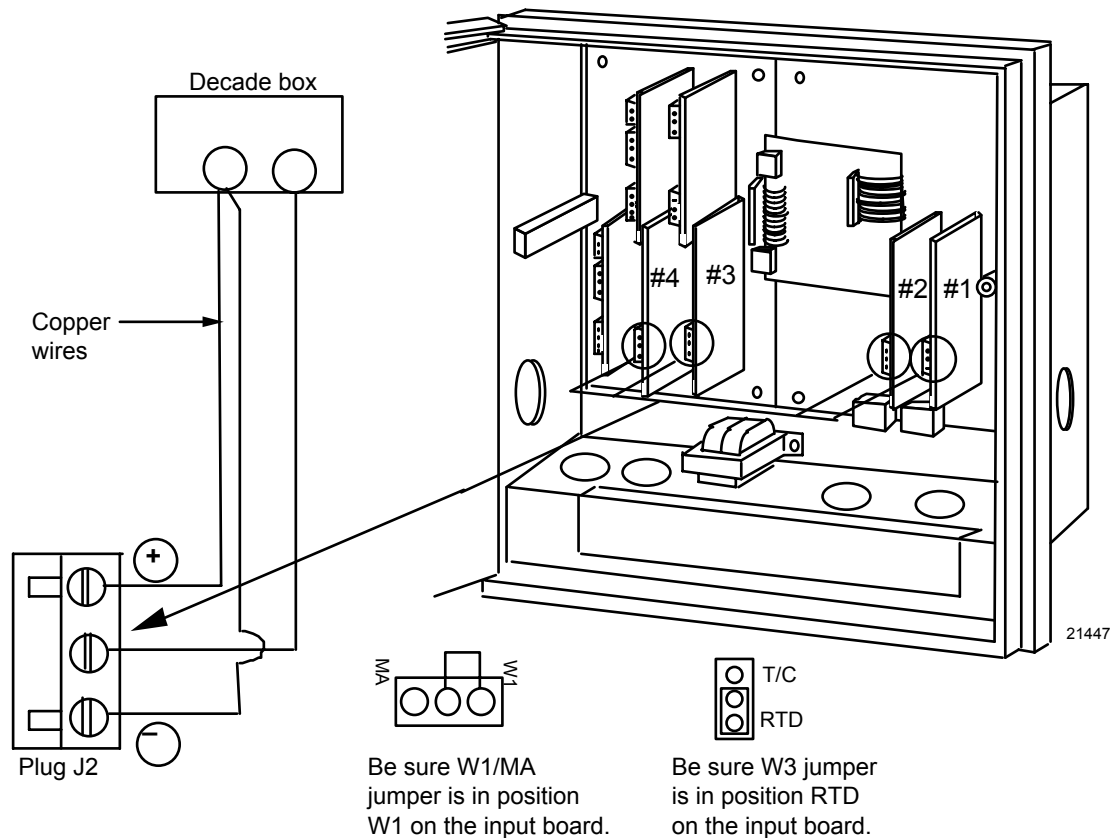

**Figure 7-6 Calibration Set Up Diagram for RTD Inputs**



**Radiamatic, millivolts, and volts inputs (except 0–10 Volts)**

Refer to Figure 7-7 and wire the recorder according to the procedure given in Table 7-10.

**Table 7-10 Set Up Wiring Procedure for Radiamatic, Millivolts, and Volts Inputs (except 0-10 Volts)**

Step	Action
1	Connect the copper wire to the calibration source (see Figure 7-7).
2	Connect the other end of the copper wire to the clamp type terminals in the plug for the applicable input connector (J2).
3	Reinstall the plug into the input connector (J2) on the applicable circuit board for input 1, input 2, input 3, or input 4.

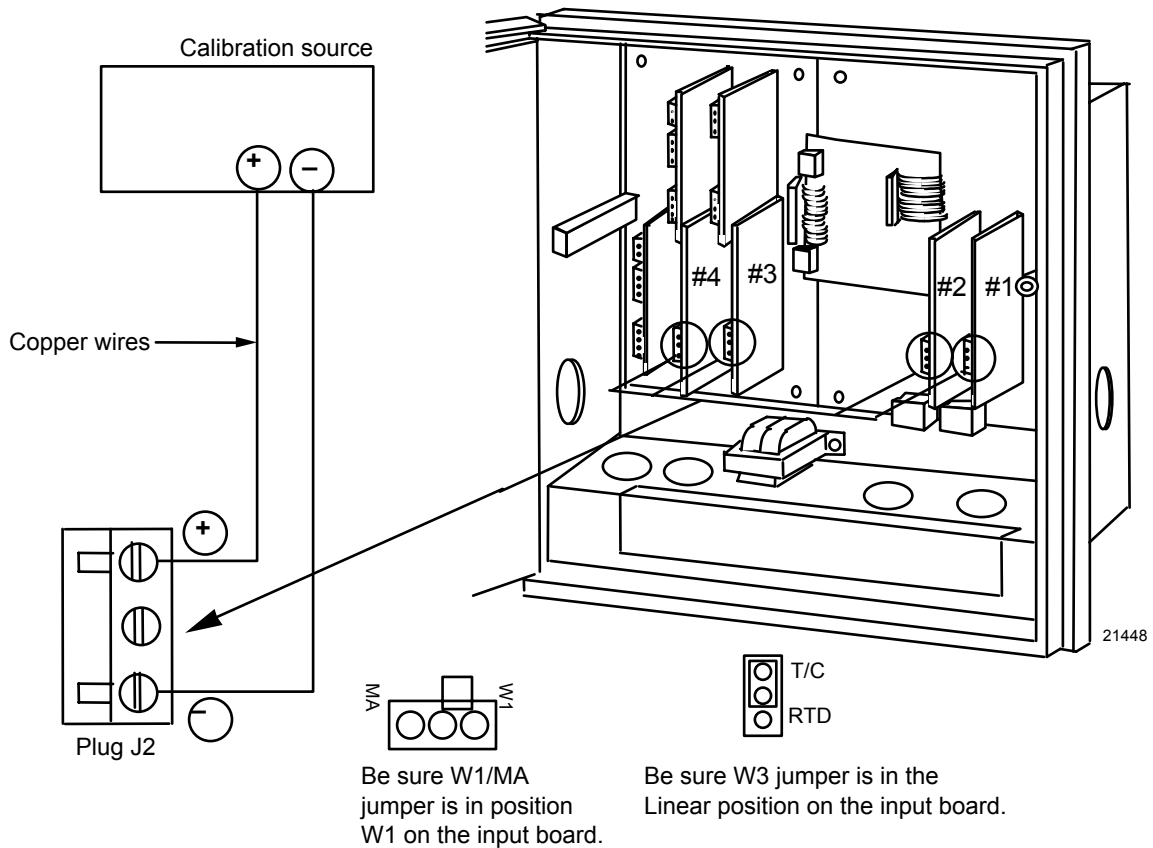

**Figure 7-7 Calibration Set Up Diagram for Radiamatic, Millivolts, and Volts Inputs (except 0-10 Volts)**

**0–10 Volt inputs**

Refer to Figure 7-8 and wire the recorder according to the procedure given in Table 7-11.

**Table 7-11 Set Up Wiring Procedure for 0–10 Volt Inputs**

Step	Action
1	Connect the copper wire to the calibration source (see Figure 7-8).
2	Connect the other end of the copper wire to the clamp type terminals in the plug for the applicable input connector (J2).
3	Reinstall the plug into the input connector (J2) on the applicable circuit board for input 1, input 2, input 3, or input 4.

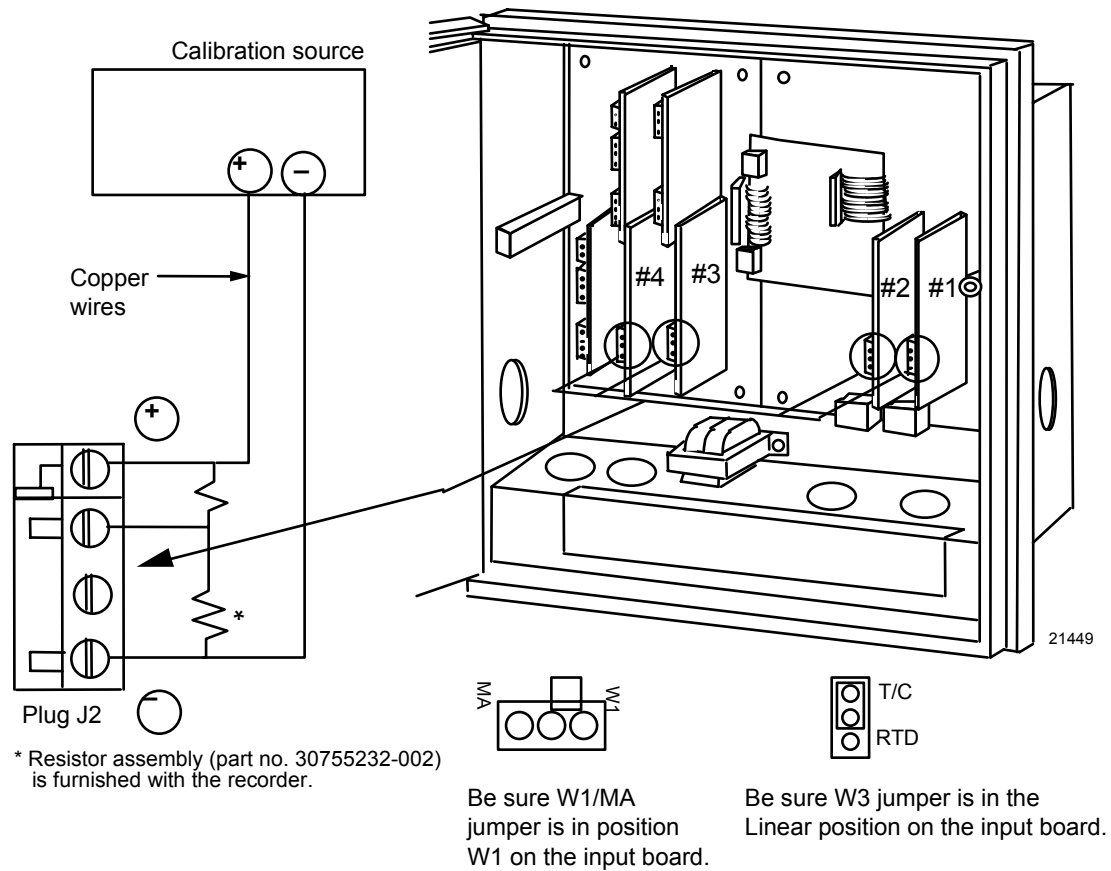

**Figure 7-8 Calibration Set Up Diagram for 0–10 Volt Inputs**

### 4–20 mA inputs

Refer to Figure 7-9 and wire the recorder according to the procedure given in Table 7-12.

**Table 7-12 Set Up Wiring Procedure for 4–20 mA Inputs**

Step	Action
1	Connect the copper wire to the calibration source (see Figure 7-9).
2	Connect the other end of the copper wire to the clamp type terminals in the plug for the applicable input connector (J2).
3	Reinstall the plug into the input connector (J2) on the applicable circuit board for input 1, input 2, input 3, or input 4.

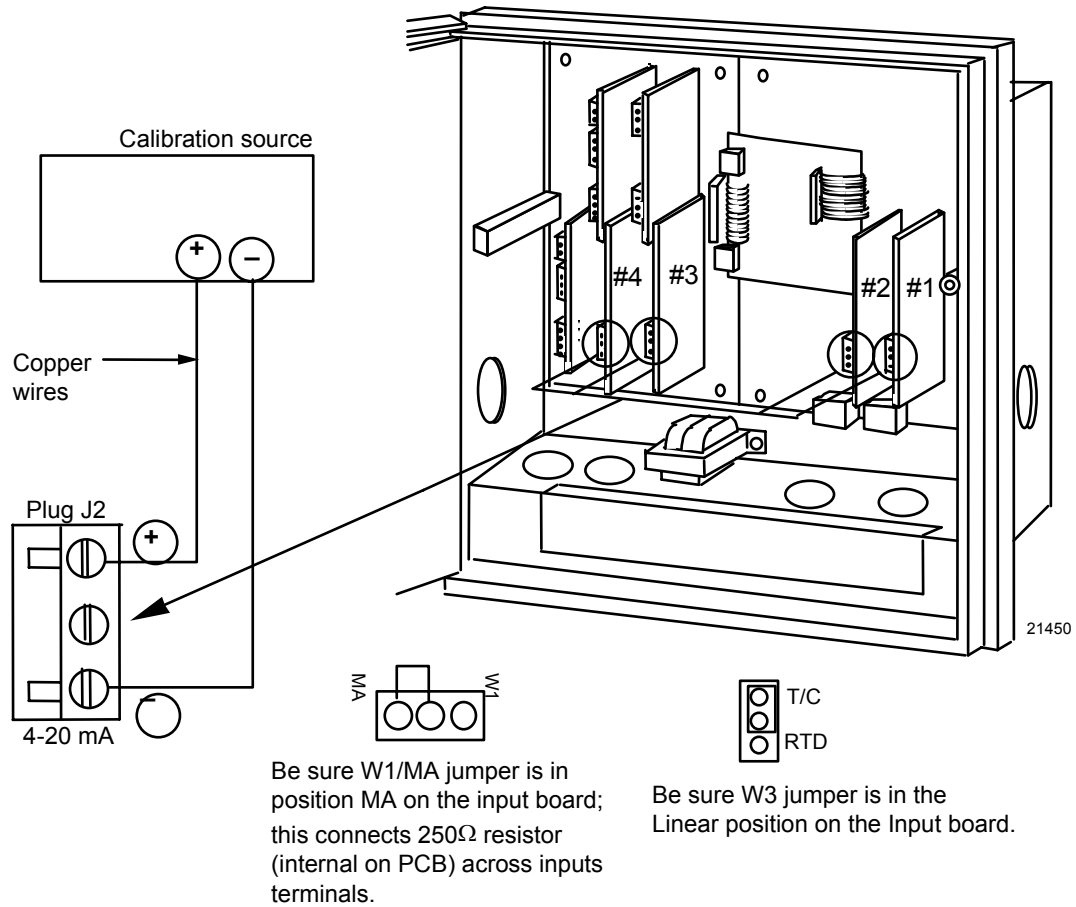

**Figure 7-9 Calibration Set Up Diagram for 4–20 mA Inputs**

## 7.6 Calibration Procedure

### Introduction

Apply power and allow the recorder to warm up for one hour before you calibrate.

- Please read “*Set Up Wiring*” before beginning the procedure.
- Make sure “LOCKOUT” is set to “NONE.” (see *Section 3 – Configuration*).
- The calibration procedure for inputs #1, #2, #3, and #4 are identical. The displays indicate the input number.



#### CAUTION

For *milliampere inputs*, be sure the current source is at zero before switching on the calibrator. Do not switch the calibrator on/off while it is connected to the recorder’s input.

---



#### ATTENTION

For *linear inputs*, avoid step changes in input signal. Vary calibration source signal smoothly from initial value to final 100 % value.

---

### Calibration procedure sequence

The calibration procedure sequence for all inputs is listed in Table 7-13.

**Table 7-13 Calibration Procedure Sequence**

Step	Operation	Press	Action/Result
1	Enter Calibration Mode	<b>SET UP</b>	Until you see: <i>Upper Display: CALIB</i> <i>Lower Display: INPUT n</i> n = 1, 2, 3, or 4
		<b>FUNC</b>	You will see: <i>Upper Display: DISABL</i> <i>Lower Display: CAL INn</i> n = 1, 2, 3, or 4
		<b>▲</b>	The calibration sequence is enabled and you will see: <i>Upper Display: BEGIN</i> <i>Lower Display: CAL INn</i>

Step	Operation	Press	Action/Result									
2	Calibrate 0 %	<b>FUNC</b>	<p>You will see:</p> <p style="padding-left: 40px;"><i>Upper Display:</i> <b>APPLY</b></p> <p style="padding-left: 40px;"><i>Lower Display:</i> <b>INn ZERO</b> n = 1, 2, 3, or 4</p> <ul style="list-style-type: none"> <li>• Adjust your calibration device to an output signal equal to the 0 % range value for your particular input sensor, see Table 7-2 for Voltage or Resistance equivalents.</li> <li>• Wait 30 seconds, then go to step 3.</li> </ul>									
	Using Ambient Temperature Method		<p><b>ATTENTION</b> If you are using the Ambient Temperature method to calibrate a thermocouple input, be sure to measure the temperature at the input terminals and subtract the equivalent millivolt value (for your particular thermocouple) from the 0 % value just prior to doing calibration.</p> <p>For example, for a Type J Thermocouple and input temperature of 68 °F:</p> <table style="margin-left: 40px;"> <tr> <td>From</td> <td style="text-align: right;">-0.885 mV</td> <td>(Type J @ 0° F)</td> </tr> <tr> <td>Subtract</td> <td style="text-align: right;"><u>-1.019 mV</u></td> <td>(Type J @ 68 °F)</td> </tr> <tr> <td>To yield</td> <td style="text-align: right;">-1.904 mV</td> <td>(calibrator output for INn ZERO)</td> </tr> </table>	From	-0.885 mV	(Type J @ 0° F)	Subtract	<u>-1.019 mV</u>	(Type J @ 68 °F)	To yield	-1.904 mV	(calibrator output for INn ZERO)
From	-0.885 mV	(Type J @ 0° F)										
Subtract	<u>-1.019 mV</u>	(Type J @ 68 °F)										
To yield	-1.904 mV	(calibrator output for INn ZERO)										
3	Calibrate 100 %	<b>FUNC</b>	<p>You will see:</p> <p style="padding-left: 40px;"><i>Upper Display:</i> <b>APPLY</b></p> <p style="padding-left: 40px;"><i>Lower Display:</i> <b>INn SPAN</b> n = 1, 2, 3, or 4</p> <p>Adjust your calibration device to an output signal equal to the 100 % range value for your particular input sensor, see Table 7-2 for voltage or resistance equivalents, wait 30 seconds, and</p> <table border="1" style="margin-left: 40px; width: 100%;"> <thead> <tr> <th style="text-align: left;">If ...</th> <th style="text-align: left;">Then ...</th> </tr> </thead> <tbody> <tr> <td>you are calibrating a thermocouple input</td> <td>Go to step 4</td> </tr> <tr> <td>you are calibrating other than a thermocouple input</td> <td>Go to step 5</td> </tr> </tbody> </table>	If ...	Then ...	you are calibrating a thermocouple input	Go to step 4	you are calibrating other than a thermocouple input	Go to step 5			
If ...	Then ...											
you are calibrating a thermocouple input	Go to step 4											
you are calibrating other than a thermocouple input	Go to step 5											
	Using Ambient Temperature Method		<p><b>ATTENTION</b> If you are using the Ambient Temperature method to calibrate a thermocouple input, be sure to measure the temperature at the input terminals and subtract the equivalent millivolt value (for your particular thermocouple) from the 100 % value.</p> <p>For example, for a Type J Thermocouple and input temperature of 68 °F:</p> <table style="margin-left: 40px;"> <tr> <td>From</td> <td style="text-align: right;">50.059 mV</td> <td>(Type J @ 1600 °F)</td> </tr> <tr> <td>Subtract</td> <td style="text-align: right;"><u>-1.019 mV</u></td> <td>(Type J @ 68 °F)</td> </tr> <tr> <td>To yield</td> <td style="text-align: right;">49.040 mV</td> <td>(calibrator output for INn SPAN)</td> </tr> </table>	From	50.059 mV	(Type J @ 1600 °F)	Subtract	<u>-1.019 mV</u>	(Type J @ 68 °F)	To yield	49.040 mV	(calibrator output for INn SPAN)
From	50.059 mV	(Type J @ 1600 °F)										
Subtract	<u>-1.019 mV</u>	(Type J @ 68 °F)										
To yield	49.040 mV	(calibrator output for INn SPAN)										

Step	Operation	Press	Action/Result
4	<p>Check the Cold Junction Temperature</p> <p><b>WARNING</b> The accuracy of the recorder is directly affected by the accuracy of this value. Change this value only if the zero and span calibration procedures did not bring the controller within the specified accuracy requirements.</p>	FUNC	<p>The calculations for zero and span are now stored and you will see:</p> <p><i>Upper Display:</i> The cold junction temperature at the rear terminals</p> <p><i>Lower Display:</i> <b>C-J TEMP</b></p> <ul style="list-style-type: none"> <li>• The value in the upper display is in the tenths of a degree. It is the current reading of the temperature as measured at the thermocouple terminals (that is, at J2) and recognized by the recorder.</li> <li>• When using the Ice Bath method, this value should be the terminal ambient temperature. <ul style="list-style-type: none"> <li>– You can change this value, if it is in error, using the ▲ or ▼ key.</li> </ul> </li> </ul>
5	Exit the Calibration Mode	FUNC	The recorder stores the calibration constants and exit calibration mode.

## 7.7 Printing Characteristics Adjustments

### Printing characteristics adjustments

Normally there is no need to adjust the printing characteristics as part of an input or output calibration procedure. However, if the chart printing appears to be faded, you can use the procedure in *Section 4 - Configuration Parameter Definitions*, Table 4-18, to make slight adjustments in the print contrast.



#### ATTENTION

To access Set Up group prompt “ADJUST”, the Set Up group prompt “LOCKOUT” must be set to “NONE”. If the group prompt “LOCKOUT” has been configured for “CALIB”, “+VIEW”, or “MAX” selection, you will not be able to access the Printing Characteristics Group prompt. Refer to *Section 3 - Configuration* for details.

---





# 8. Output Calibration

## 8.1 Overview



### SHOCK HAZARD – WARNING!

Disregard of these instructions may cause injury or death.

OUTPUT CALIBRATION MAY REQUIRE ACCESS TO HAZARDOUS LIVE CIRCUITS, AND SHOULD ONLY BE PERFORMED BY QUALIFIED SERVICE PERSONNEL. MORE THAN ONE SWITCH MAY BE REQUIRED TO DE-ENERGIZE UNIT BEFORE CALIBRATION.

### Introduction

This section describes the field calibration procedures for the following types of outputs:

- Current Output
- Position Proportional Output
- Auxiliary Output



### ATTENTION

Calibration for Control Outputs #1 and #2 is identical except for the particular printed circuit board involved.

### What's in this section?

This section contains the following topics:

	Topic	See Page
8.1	Overview	219
8.2	Current Proportional Output/Aux Out 2 and 3 Calibration <ul style="list-style-type: none"><li>• Introduction</li><li>• Equipment needed</li><li>• Calibrator connections</li><li>• Calibration Procedure</li></ul>	220 220 220 221
8.3	Position Proportional and Three Position Step Output Calibration <ul style="list-style-type: none"><li>• Position proportional control</li><li>• Equipment needed</li><li>• Connections</li><li>• Auto mode vs manual mode</li><li>• Displayed values</li><li>• Calibration Procedure</li></ul>	222 222 222 222 222 222
8.4	Auxiliary Output Calibration <ul style="list-style-type: none"><li>• Introduction</li><li>• Equipment needed</li><li>• Calibrator connections</li><li>• Calibration Procedure</li></ul>	225 225 225 226

## 8.2 Current Proportional Output/Aux Out 2 and 3 Calibration

### Introduction

Calibrate the recorder so that the output provides the proper amount of current over the desired range.

- The recorder can provide an output current range of from 2 to 21 milliamperes and can be calibrated at 4 mA for 0 % of output and 20 mA for 100 % of output or any other values between 2 and 21 mA.

### Equipment needed

You will need a standard shop type milliammeter, with whatever accuracy is required, capable of measuring 0 to 20 milliamps.

### Calibrator connections

Refer to Figure 8-1 and wire the recorder according to the procedure given in Table 8-1.

**Table 8-1 Set Up Wiring Procedure Current Proportional Output/Aux Out 2 and 3**

Step	Action
1	With the power off, door open, and the chart plate swung out; tag and disconnect field wiring from the plug in connector J1 on the appropriate control output PCB (see Figure 8-1).
2	Observing polarity, connect a milliammeter's leads to the plug for connector J1.
3	Close the chart plate; apply power and allow the recorder to warm up 15 minutes before you calibrate.

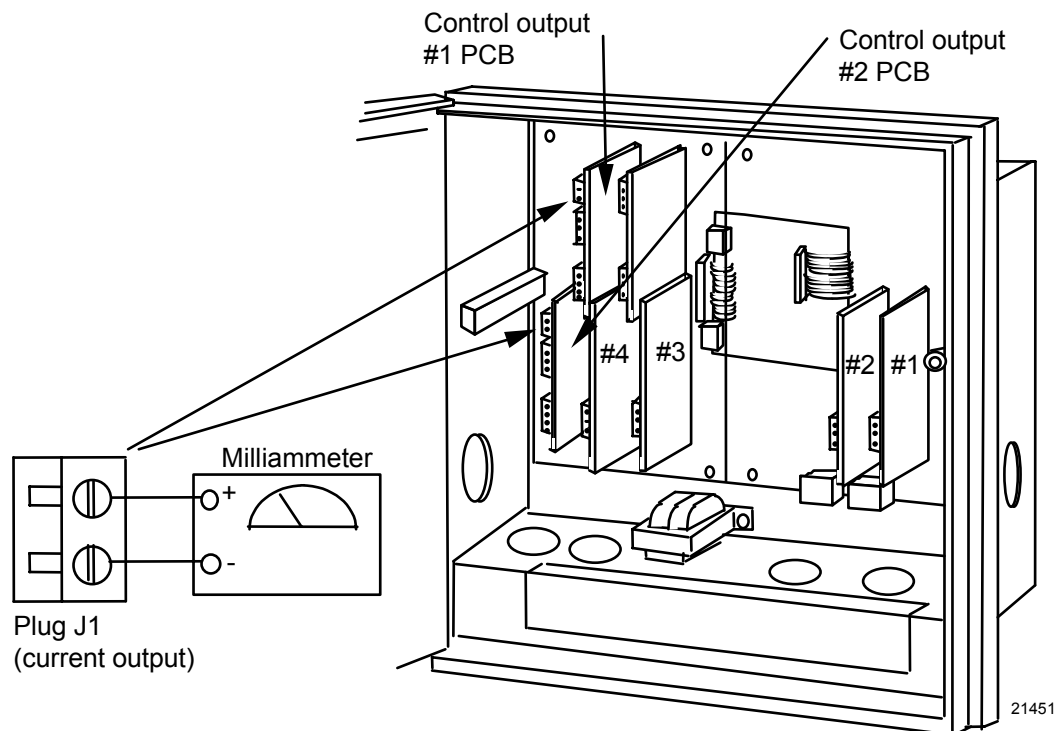

**Figure 8-1 Test Equipment Connections for Calibrating Current Proportional Output**

## Procedure

The procedure for calibrating the Current Proportional Output is listed in Table 8-2. Make sure "LOCKOUT" in the Set Up group is set to "NONE." See *Section 3 – Configuration*. Also, "CONTROL 1/2" must be enabled and "OUT ALG" must be set to "CURRNT" in the Control Set Up group.



### ATTENTION

Follow this procedure when calibrating Auxiliary Output #2 or #3. Make sure "LOCKOUT" in the Set Up group is set to "NONE" and "AUX OUT" must **NOT** be disabled in the Auxiliary Output group.

**Table 8-2 Current Proportional Output/Aux Output 2 and 3 Calibration Procedure**

Step	Operation	Press	Action/Result
1	Enter Calibration Mode	<b>SET UP</b>	Until you see: <i>Upper Display: CALIB</i> <i>Lower Display: CURRENT</i>
2	Calibrate 0 %	<b>FUNC</b>	You will see: <i>Upper Display: (a value)</i> (approximately 380) <i>Lower Display: ZERO VAL</i>
		<b>▲ or ▼</b>	Until the desired 0 % output is read on the milliammeter. Use the values shown below depending on the action of your recorder.  4 mA For 4 to 20 mA Direct Action 20 mA For 4 to 20 mA Reverse Action
3	Calibrate 100 %	<b>FUNC</b>	Stores the 0 % value and you will see: <i>Upper Display: (a value)</i> (approximately 1890) <i>Lower Display: SPAN VAL</i>
		<b>▲ or ▼</b>	Until the desired 100 % output is read on the milliammeter. Use the values shown below depending on the action of your recorder.  20 mA For 4 to 20 mA Direct Action 4 mA For 4 to 20 mA Reverse Action
4	Exit the Calibration Mode	<b>FUNC</b>	The recorder stores the span value.
		<b>LOWR DISP</b>  or <b>SET UP</b>	To exit the calibration mode.

## 8.3 Position Proportional and Three Position Step Output Calibration

### Position proportional control

When the DR4500A Recorder has a position proportional control output, calibrate the recorder so that the increase and decrease relays operate properly with respect to the position of the external feedback slidewire.

### 3 Position Step control

This model only requires that the “Motor Time” be entered as shown in the calibration procedure. FULL CALIBRATION IS NOT REQUIRED.

### Equipment needed

None

### Connections

Apply power and allow the recorder to warm up 15 minutes before you calibrate.

Leave all field wiring connected to the plugs in connectors J2 and J5 on the appropriate control output printed circuit board.

### Auto mode vs manual mode

There are two ways in which to calibrate Position Proportional control:  
AUTO mode or MANUAL mode.

### Rules for auto mode vs manual mode

The auto-mode selection must be done at least once before the manual mode will operate properly. Failure to use the auto-mode procedure will prevent the recorder from going into automatic control mode.

### Displayed values

During the auto-mode calibration procedure, the values being displayed are used only to indicate if the motor is still traveling.

To view the actual calibration value, use the manual mode after the auto-mode is completed. These values can be changed for purposes of tweaking the calibration.

### Procedure

The procedure for calibrating the position proportional output and 3 Position Step control output is listed in Table 8-3.

- Make sure “LOCKOUT” in the Set Up group is set to “NONE.” See *Section 3 – Configuration*. Also, “CONTROL 1/2” must be enabled in the Control Set Up group.
- For “*Three Position Step Control Output models*”, do steps 1 and 2 only. Make sure “CONT ALG” = “3P STEP” in the Control Set Up group.
- For “*Position Proportional Output*”, follow the entire calibration procedure. Make sure “CONT ALG” = “PID A” and “OUT ALG” = “POSITN” in the Control 1 Set Up group.

**Table 8-3 Position Proportional and 3 Position Step Output Calibration Procedure**

Step	Operation	Press	Action/Result
1	Enter Calibration Mode	<b>SET UP</b>	Until you see: <i>Upper Display: CALIB</i> <i>Lower Display: POS PROP</i>
2	Set Motor Traverse Time  NOTE: This is the time it takes the motor to travel from 0 % to 100 %.	<b>FUNC</b>	Until you see: <i>Upper Display: (a value)</i> <i>Lower Display: MTR TIME</i>
		▲ or ▼	Until the proper motor stroke time is reached (see the motor specs or measure the time).  • Range of setting = 5 to 255 Seconds
3	Select Automatic or Manual Calibration	<b>FUNC</b>	Until you see: <i>Upper Display: DISABL</i> <i>Lower Display: POS PROP</i>  • You can calibrate the control output manually or let the recorder calibrate the control output automatically.  • In the "Automatic Calibration Mode" (DO AUTO), the control relays automatically move the motor in the proper direction.  • If desired, however, the motor may be manually positioned to 0 % and 100 % positions. Disconnect the relay wires. "DO MAN".  • In the "Manual Calibration Mode" (DO MAN) the motor does not move. Instead, the existing 0 % and 100 % values may be changed with the ▲ or ▼ keys.
		▲ or ▼	Select automatic or manual calibration.  <i>Upper Display: DO AUTO or DO MAN</i> <i>Lower Display: POS PROP</i>  • If you select DO AUTO, go to step 4. • If you select DO MAN, go to step 6.  <b>ATTENTION</b> When calibration is terminated, this selection reverts to DISABL.
4	<b>DO AUTO</b> Set 0 % value	<b>FUNC</b>	The decrement relay is turned on to move the motor to 0 % position.  <i>Upper Display: (counts of feedback slidewire)</i> <i>(0 to 2047)</i> <i>Lower Display: ZERO VAL</i>  • When the motor stops, the display should stop counting; go to the next step.

Step	Operation	Press	Action/Result
5	Set 100 % value	<b>FUNC</b>	The increment relay is turned on to move the motor to 100 % position.  <i>Upper Display: (counts of feedback slidewire)                      (0 to 2047)</i> <i>Lower Display: <b>SPAN VAL</b></i>  • When the motor stops, the display should stop counting, then go on to step 8.
6	<b>DO MAN</b> Set 0 % value	<b>FUNC</b>	You will see:  <i>Upper Display: (existing zero calibration value                      in counts) (approximately 100)</i> <i>Lower Display: <b>ZERO VAL</b></i>
		▲ or ▼	Until the desired zero value is reached in the upper display.  <i>Upper Display: (desired zero value)</i> <i>Lower Display: <b>ZERO VAL</b></i>
7	Set 100 % value	<b>FUNC</b>	The recorder stores the 0 % value and you will see:  <i>Upper Display: (existing span calibration value                      in counts) (approximately 1500)</i> <i>Lower Display: <b>SPAN VAL</b></i>
		▲ or ▼	Until the desired span value is reached in the upper display.  <i>Upper Display: (desired span value)</i> <i>Lower Display: <b>SPAN VAL</b></i>  For manual calibration, the motor does not move from its position prior to the start of position proportional calibration.
8	Exit the Calibration Mode	<b>FUNC</b>	The recorder stores the 100 % value.
		<b>LOWR                      DISP</b>  or  <b>SET                      UP</b>	To exit the calibration mode.

## 8.4 Auxiliary Output Calibration

### Introduction

Calibrate the recorder so that the auxiliary output provides the proper amount of current over the desired range.

- The recorder can provide an auxiliary output current range of from 2 to 21 milliamperes and can be calibrated at 4 mA for 0 % of output and 20 mA for 100 % of output or any other values between 2 and 21 mA.

### Equipment needed

You will need a standard shop type milliammeter, with whatever accuracy is required, capable of measuring 0 to 20 milliamps.

### Calibrator connections

Refer to Figure 8-2 and wire the recorder according to the procedure given in Table 8-4.

**Table 8-4 Set Up Wiring Procedure Auxiliary Output**

Step	Action
1	With the power off, door open, and the chart plate swung out; tag and disconnect field wiring from the plug in connector J2 on the auxiliary output PCB (see Figure 8-2).
2	Observing polarity, connect a milliammeter's leads to the plug for connector J2.
3	Close the chart plate; apply power and allow the recorder to warm up 15 minutes before you calibrate.

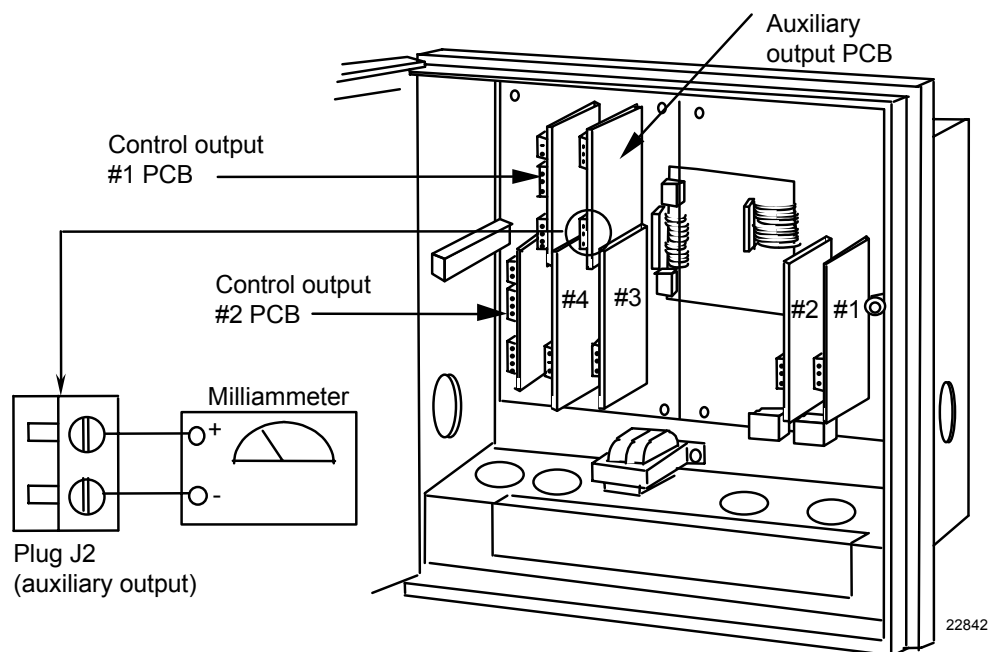

**Figure 8-2 Test Equipment Connections for Calibrating Auxiliary Output**

**Procedure**

The procedure for calibrating the Auxiliary Output is listed in Table 8-5. Make sure “LOCKOUT” in the Set Up group is set to “NONE.” See *Section 3 – Configuration*. Also, “AUX OUT” must **NOT** be disabled in the Auxiliary Output group.

**Table 8-5 Auxiliary Output Calibration Procedure**

Step	Operation	Press	Action/Result
1	Enter Calibration Mode	<b>SET UP</b>	Until you see: <i>Upper Display: CALIB</i> <i>Lower Display: AUX OUT</i>
2	Calibrate 0 %	<b>FUNC</b>	You will see: <i>Upper Display: (a value)</i> <i>Lower Display: ZERO VAL</i>
		▲ or ▼	Until the desired 0 % (4 mA) output is read on the milliammeter.
3	Calibrate 100 %	<b>FUNC</b>	Stores the 0 % value and you will see: <i>Upper Display: (a value)</i> <i>Lower Display: SPAN VAL</i>
		▲ or ▼	Until the desired 100 % (20 mA) output is read on the milliammeter.
4	Exit the Calibration Mode	<b>FUNC</b>	The recorder stores the span value.
		<b>LOWR DISP</b>  or <b>SET UP</b>	To exit the calibration mode.



**ATTENTION**

The calibration for Auxiliary Outputs #2 and #3 follows the procedure for calibrating the current proportional output (*refer to Subsection 8.2*).

---



## 9. Troubleshooting / Service

### 9.1 Overview



---

**SHOCK HAZARD – WARNING!**

**Disregard of these instructions may cause injury or death.**

TROUBLESHOOTING MAY REQUIRE ACCESS TO HAZARDOUS LIVE CIRCUITS, AND SHOULD ONLY BE PERFORMED BY QUALIFIED SERVICE PERSONNEL. MORE THAN ONE SWITCH MAY BE REQUIRED TO DE-ENERGIZE UNIT BEFORE SERVICING.

---

#### Introduction

This section explains how to troubleshoot the DR4500A recorder using self-diagnostic test results and error messages as well as some visual failure symptoms. Using an optimum replacement unit repair philosophy, trouble is traced to a printed circuit board (PCB)/hardware assembly level rather than to an individual PCB/hardware assembly component. While troubleshooting is straightforward, we recommend that only trained service technicians repair the recorder.

#### What's in this section?

The following topics are covered in this section.

	<b>Topic</b>	<b>See Page</b>
9.1	Overview	227
9.2	Troubleshooting Aids	229
9.3	Self Diagnostics	231
9.4	Visual Failure Symptoms	237
9.5	Troubleshooting Procedures	238

#### Types of problems

Instrument performance can be adversely affected by installation and application problems as well as hardware problems. We recommend that you investigate the problems in the following order:

- Installation related problems
- Application related problems
- Hardware and software related problems

and use the information presented in this section to solve them.

If a replacement of any part is required, follow the instructions shipped with the replacement part.

### Installation related problems

Read the Installation section in this manual to make sure the DR4500A has been properly installed. The installation section provides information on protection against electrical noise, connecting external equipment to the recorder, and shielding and routing external wiring.



#### ATTENTION

System noise induced into the recorder will result in diagnostic error messages recurring. If the diagnostic error messages can be cleared, it indicates a “soft” failure and is probably noise related.

If system noise is suspected, completely isolate the recorder from all field wiring. Use calibration sources to simulate PV and check all recorder and control functions; that is, Pen functions, Chart Trace, Gain, Rate, Reset, Output, Alarms, etc.

---

### Application related problems

Review the application of the recorder; then, if necessary, direct your questions to the local sales office.

### Hardware and software related problems

Use the troubleshooting error message prompts and recorder failure symptoms to identify typical failures which may occur in the recorder. Follow the troubleshooting procedures to correct them.

## 9.2 Troubleshooting Aids

### Self diagnostics

The DR4500A recorder runs self-diagnostic tests to monitor the recorder's general health. The tests are divided into three main groups and will produce an error message when failed.

An error message can occur

- at power-up — run when power is cycled off and on,
- during continuous background tests while in normal operation, and
- when the Status Tests are requested by the operator.

Table 9-4 lists all the error message prompts that you could see, the reason for the failure, and how to correct the problem

### Visual failure symptoms

Other failures may occur that deal with the power, pen functions, chart rotation, output, or alarms. Refer to the visual failure symptom in Table 9-5 to determine what is wrong and the troubleshooting procedures to use to correct the problem.

### Check Installation

If a set of symptoms still persists, refer to *Section 2 - Installation* and ensure proper installation and proper use of the recorder in the system.

### Customer support

If you cannot solve the problem using the troubleshooting procedures listed in this section; get the **model number** and **serial number** from the label on the chart plate, and **software** version (see "Determining the software version") then:

- call Customer Support Phone Number  
1-800-423-9883 USA and Canada

If it is determined that a hardware problem exists and the recorder is still within the two year warranty, a replacement recorder will be shipped with instructions for returning the defective unit.

### Determining the software version

Table 9-1 lists the procedure for identifying the software version number.

**Table 9-1 Identifying the software version**

<b>Step</b>	<b>Operation</b>	<b>Press</b>	<b>Action/Result</b>
<b>1</b>	Select STATUS Set Up Group	<b>SET UP</b>	Until you see:  <i>Upper Display:</i> <b>READ</b> <i>Lower Display:</i> <b>STATUS</b>
<b>2</b>	Read the software version	<b>FUNC</b>	Until you see:  <i>Upper Display:</i> <b>(Software Version Number)</b> <i>Lower Display:</i> <b>VERSION</b>  Please give this number to the Customer Support person. It will indicate which version of DR4500A you have and help them determine a solution to your problem.

### Troubleshooting

The troubleshooting procedures are divided into two parts:

- Self Diagnostics – Error Message Prompts, and
- Visual Failure Symptoms.

If a “Failed” indication is given for one of the power-up tests and/or an error message prompt blinks in the lower display, refer to the Self Diagnostic error message prompts.

If erratic operation is observed, refer to the Visual Failure symptoms.

In either case, run the status tests to verify the status of the recorder’s basic self-diagnostic tests.

## 9.3 Self Diagnostics

### Power-up tests

When the recorder is powered-up, four tests are run by the DR4500A software to ensure memory integrity.

- As the tests are run, the displays appear as shown in Table 9-2.

**Table 9-2 Power-up tests**

Lower Display	Upper Display
RAM TEST	PASS or FAIL
CONFTEST (configuration checksum)	PASS or FAIL
CAL TEST (working calibration)	PASS or FAIL
BATTERY*	PASS or FAIL

\*Battery test failure does not cause a failsafe.

### Failsafe

- If control is configured, and any of these tests fail, “FAIL” appears momentarily in the upper display, then a display test is run, after which the controller goes into manual mode and you will see:

*Upper Display: (PV value)*

*Lower Display: FAILSAFE (blinking)*

Refer to “*Device Status*” (next page) to determine which tests have failed and how to correct them.

- If control is *not* configured, self-test failures will be displayed periodically as other error messages are presently displayed (CNFG ERR, CAL1 ERR, CAL2 ERR, or BATT LOW).

### Device status

When required, the results of the power-up tests can be checked to determine the reason the recorder has gone to "Failsafe".

The following procedure in Table 9-3 tells you how to display the results of the latest tests run. Table 9-4 lists the tests, the reason for the failure, and how to correct the problem.

**Table 9-3 Displaying the test results**

<b>Step</b>	<b>Operation</b>	<b>Press</b>	<b>Action/Result</b>
1	Select STATUS Set Up Group	<b>SET UP</b>	Until you see:  <i>Upper Display:</i> <b>READ</b>  <i>Lower Display:</i> <b>STATUS</b>
2	Read the status tests results	<b>FUNC</b>	Until you see:  <i>Upper Display:</i> <b>NO</b> or <b>YES</b> (YES indicates a failure)  <i>Lower Display:</i> <b>FAILSAFE</b>  <ul style="list-style-type: none"> <li>• Successive presses of the <b>FUNC</b> key will display the results of the tests (PASS or FAIL) in the following order:                             RAM TEST                            CONFTEST                            CAL TEST                            FACT CRC                            BATTERY</li> <li>• Identify the problem from the error message and correct the failure as shown under "lower display indication" in Table 9-4.</li> </ul>

## Error message prompts

The messages listed in Table 9-4 may appear during the power-up test or status test, or they may blink in the lower display as the result of ongoing background tests that verify data and memory integrity.

Simultaneous error messages will be displayed in rotation.

Table 9-4 lists the error message, the test group that prompted the message, the reason for the failure, and how to correct the problem.

**Table 9-4 Error message prompts**

Lower Display Indication	Test Group	Reason for Failure	How to Correct the Problem
<b>FAILSAFE (Note 1)</b>	Status or Background	This error message shows whenever the recorder goes into a failsafe mode of operation. This will happen if control is enabled and: <ul style="list-style-type: none"> <li>• a power-up test fails,</li> <li>• a specific background test fails.</li> </ul>	<ol style="list-style-type: none"> <li>1. Run through the "Device Status" check (page 232) to determine the reason for the failsafe indication.</li> <li>2. Identify the other failure message in the display and correct the problem according to the recommendations given in this table for that particular error message.</li> </ol>
<b>RAM TEST (Note 1)</b>	Power-up	RAM failure	<ol style="list-style-type: none"> <li>1. Cycle power.</li> <li>2. Check "Device Status" (page 232) to see if error clears.</li> <li>3. If error doesn't clear, replace the main printed circuit board.</li> </ol>
<b>CONFTEST (Note 1)</b>	Power-up	Configuration data is in error.	<ol style="list-style-type: none"> <li>1. Check all the configuration prompts for accuracy. <ul style="list-style-type: none"> <li>• See <i>Section 3 - Configuration</i> for selections and limits.</li> </ul> </li> <li>2. Change <i>any</i> configuration item, check "Device Status" to see if CONFTEST=PASS, return configuration item to original value. <ul style="list-style-type: none"> <li>• See <i>Section 3 - Configuration</i> for instructions to change a configuration item.</li> </ul> </li> </ol>

Lower Display Indication	Test Group	Reason for Failure	How to Correct the Problem
<b>CNFG ERR</b>	Background	Configuration data is in error.	<ol style="list-style-type: none"> <li>1. Check all the configuration prompts for accuracy. <ul style="list-style-type: none"> <li>• See <i>Section 3 - Configuration</i> for selections and limits.</li> </ul> </li> <li>2. Change <i>any</i> configuration item, then return it to the original value. <ul style="list-style-type: none"> <li>• See <i>Section 3 - Configuration</i> for instructions to change a configuration item.</li> </ul> </li> </ol>
<b>CAL TEST (Note 1)</b>	Power-up	The working calibration constants in the recorder are in error.	<ol style="list-style-type: none"> <li>1. Change to a different input type. <ul style="list-style-type: none"> <li>• See <i>Section 3 – Configuration</i>.</li> </ul> </li> <li>2. Check “Device Status” (page 232) to see if FACT CRC=PASS. <ul style="list-style-type: none"> <li>• If PASS—return to original input type.</li> <li>• If FAIL—field calibrate. Refer to <i>Section 7 – Input Calibration</i>.</li> </ul> </li> </ol>
<b>CAL1 ERR</b>	Background	Working CAL TEST failure (Control 1, Input 1, Input 2)	<ol style="list-style-type: none"> <li>1. Change to a different input type. <ul style="list-style-type: none"> <li>• See <i>Section 3 – Configuration</i>.</li> </ul> </li> <li>2. Check “Device Status” (page 232) to see if FACT CRC=PASS. <ul style="list-style-type: none"> <li>• If PASS—return to original input type.</li> <li>• If FAIL—field calibrate Control Output #1, Input 1, or Input 2. Refer to <i>Section 7 – Input Calibration</i> and <i>Section 8 – Output Calibration</i>.</li> </ul> </li> </ol>
<b>CAL2 ERR</b>	Background	Working CAL TEST failure (Control 2, Output)	<ol style="list-style-type: none"> <li>1. Field calibrate Control Output 2. <ul style="list-style-type: none"> <li>• Refer to <i>Section 8 – Output Calibration</i>.</li> </ul> </li> </ol>
<b>FACT CRC</b>	Check “Device Status” See page 232.	Factory-set input constants have been changed due to the change in input type.	<ol style="list-style-type: none"> <li>1. Check background test error message being displayed.</li> <li>2. Recalibrate Input or Output. <ul style="list-style-type: none"> <li>• Refer to <i>Section 7 – Input Calibration</i> or <i>Section 8 – Output Calibration</i>.</li> </ul> </li> </ol>



Lower Display Indication	Test Group	Reason for Failure	How to Correct the Problem
<b>EE FAIL</b>	Background	Unable to write to nonvolatile memory. Any time you change a parameter and it is not accepted, you will see EE FAIL.	<ol style="list-style-type: none"> <li>1. Check the accuracy of the parameter and re-enter.</li> <li>2. Try to change something in configuration.</li> <li>3. Call Customer Support 1-800-423-9883 USA and Canada.</li> </ol>
<b>IN1FAIL IN2FAIL IN3FAIL IN4FAIL</b>	Background	Two consecutive failures of input 1 integration (for example, cannot make analog to digital conversion)	<ol style="list-style-type: none"> <li>1. Be sure the range and actuation are configured correctly.</li> <li>2. Check the input source.</li> <li>3. Recalibrate. Refer to <i>Section 7 - Input Calibration</i>.</li> <li>4. Replace the input card.</li> <li>5. Call Customer Support 1-800-423-9883 USA and Canada.</li> </ol>
<b>BATTERY</b>	Power-up or Status	Battery test failure.	<ol style="list-style-type: none"> <li>1. Replace battery.</li> <li>2. Call Customer Support 1-800-423-9883 USA and Canada</li> </ol>
<b>BATT LOW</b>	Background		
<b>PV LIMIT</b>	Background	Process Variable is out of range. $\pm 10\%$ of range	<ol style="list-style-type: none"> <li>1. Be sure pen input configuration is correct.</li> <li>2. Check the displayed PV value to see if it is outside input limits.</li> <li>3. Call Customer Support 1-800-423-9883 USA and Canada.</li> </ol>
<b>RV LIMIT</b>	Background	The result of the formula shown below is beyond the range of the remote variable.  $RV = INP2 \times RATIO + BIAS$	<ol style="list-style-type: none"> <li>1. Make sure the input signal is correct.</li> <li>2. Make sure the ratio and bias settings are correct.</li> <li>3. Go to CONTROL prompt REMOTE SOURCE and change REMOTE to 1LOCAL.</li> </ol>
<b>SW FAIL SW2 FAIL</b>	Background	Position proportional slidewire feedback failure	<ol style="list-style-type: none"> <li>1. Check motor slidewire connections.</li> <li>2. Recalibrate the slidewire motor position.</li> <li>3. Replace the control card.</li> </ol>

Lower Display Indication	Test Group	Reason for Failure	How to Correct the Problem
<b>IN1RNG</b> <b>IN2RNG</b> <b>IN3RNG</b> <b>IN4RNG</b>	Background	Input out of range. The process input is outside the range limits.	<ol style="list-style-type: none"> <li>1. Make sure the range and actuation are configured properly.</li> <li>2. Check the input source.</li> <li>3. Restore the factory calibration:               <ol style="list-style-type: none"> <li>a) Disconnect the wiring from the terminals on plug J2 on the input board (see Figure 2-13). Place a jumper across these terminals. The controller should read room temperature if it is configured for a thermocouple input.</li> <li>b) If it does not read room temperature, see <i>Section 3 - Configuration</i> and change the IN1TYP prompt in the INPUT 1 group to another type of thermocouple.</li> <li>c) After the change, press <b>FUNC</b> key, then the <b>LOWR DISP</b> key. The controller should read the correct room temperature. If it does not, the unit has an input failure.</li> <li>d) Repeat step b. This time switch the IN1TYP back to the originally selected thermocouple.</li> <li>e) Repeat step c. The controller is restored with factory calibration.</li> <li>f) Remove the jumper and reconnect the thermocouple to plug J2.</li> </ol> </li> <li>4. Field calibrate. See <i>Section 7 – Input Calibration</i>.</li> <li>5. Replace the input card.</li> <li>6. Call Customer Support 1-800-423-9883 USA and Canada.</li> </ol>

NOTE 1: Will appear in “STATUS” Set Up Group—See procedure for displaying the test results on page 232.

## 9.4 Visual Failure Symptoms

### Introduction

In addition to the error message prompts, there are visual failure symptoms that can be identified by noting the erratic recorder functions.

### Symptoms

Compare your symptoms with those shown in Table 9-5 and refer to the troubleshooting procedure indicated to correct the problem.

**Table 9-5 Visual failure symptoms**

Symptom	Troubleshooting Procedure
Recorder will not operate	1
Recorder operation is normal but pen trace is incorrect	2
Chart rotates at wrong speed or will not rotate (pen indication correct)	3
Pen remains at high end of range when input signal is low	4
Pen does not move when input signal changes	5
A key does not respond and/or a display does not light	6
Displayed output does not agree with controller output	
Current Proportional Output Type	7
Position Proportional Output Type	8
Single or Dual Relay Output Type	9
Duplex Current/Time or Time/Current Proportional Output Type	10
Auxiliary Output Type	11
External Alarm Function does not operate properly	12
Modbus Communications Failure	13

## 9.5 Troubleshooting Procedures

### Introduction

The troubleshooting procedures for the Visual Failure Symptoms are listed in numerical order as they appear in Table 9-5. Each procedure lists what to do if you have that particular failure and how to do it or where to find the data needed to accomplish the task. Progressive steps provide aid in finding and fixing the problem.

### Equipment needed

You will need the following equipment in order to troubleshoot the symptoms listed in the tables that follow:

- DC Milliammeter – mA<sub>dc</sub>
- Calibration sources – T/C, mV, Volt, etc.
- Voltmeter

**Table 9-6 Procedure #1—Troubleshooting recorder failure symptoms**

Step	What to do	How to do it or where to find the data
1	Check the fuse on the main printed circuit board.	Replace if defective.
2	Check the supply voltage.	Measure the line voltage across J10 on the Main printed circuit board.
3	Check the connections to J10 on the main printed circuit board.	Refer to <i>Subsection 2.6 - Input Wiring Procedures (Figure 2-12 AC Line Power Wiring)</i> .
4	Check the transformer leadwire connections to the main printed circuit board.	Refer to Figure 10-5 in <i>Section 10 - Parts List</i> .
5	Check the system for brown-outs, heavy load switching, etc.; and conformance to installation instructions.	Refer to <i>Section 2 - Installation</i> .
6	Replace the transformer.	Disconnect the transformer lead wires from the main printed circuit board. Replace the transformer and tighten the screws. Connect the lead wires to the main printed circuit board.
7	Call Technical Assistance Center.	1-800-423-9883 USA and Canada

**Table 9-7 Procedure #2—Troubleshooting pen trace failure symptoms**



**WARNING**

Do not lubricate the plastic gears on the chart and pen motors.

Step	What to do	How to do it or where to find the data
1	Check the sensor for the proper type and its ability to function.	Verify the input configuration data and operation of the sensor.
2	Recalibrate the recorder.	Refer to <i>Section 7 - Input Calibration</i> . For thermocouple input, be sure to confirm cold-junction temperature calibration.
3	Replace the servo plate assembly.	Refer to the instructions included with the replacement part.
4	Call Technical Assistance Center.	1-800-423-9883 USA and Canada

**Table 9-8 Procedure #3—Troubleshooting chart rotation failure symptoms**



**WARNING**

Do not lubricate the plastic gears on the chart and pen motors.

Step	What to do	How to do it or where to find the data
1	Check the chart installation.	Be sure the drive pin on the hub is in the drive hole on the chart.
2	Check the configured chart speed value and change it, if required.	Refer to <i>Section 3 - Configuration</i> .
3	Check the motor cable plug connection at connector J7 on the main printed circuit board.	Visually examine the plug and reset it.
4	Replace the chart motor.	Refer to the instructions included with the replacement part.
5	Call Technical Assistance Center.	1-800-423-9883 USA and Canada

**Table 9-9 Procedure #4—Troubleshooting chart rotation failure symptoms**



**WARNING**

**Do not lubricate the plastic gears on the chart and pen motors.**

Step	What to do	How to do it or where to find the data
1	Check the sensor and lead wires for continuity. Check the connections.	Replace the sensor lead wires as needed. Tighten the connections.
2	Check the pen and input configuration data.	Refer to <i>Section 3 - Configuration</i> .
3	Replace the servo plate assembly.	Refer to the instructions included with the replacement part.
4	Call Technical Assistance Center.	1-800-423-9883 USA and Canada

**Table 9-10 Procedure #5—Troubleshooting pen failure symptoms**



**WARNING**

**Do not lubricate the plastic gears on the chart and pen motors.**

Step	What to do	How to do it or where to find the data
1	Check the sensor and lead wires for continuity. Check the connections.	Replace the sensor lead wires as needed. Verify and tighten the input connections.
2	Check the pen arm for secure mechanical attachment to the servo shaft.	Verify that the flat-head screw that attaches the pen arm to the plastic servo gear on the servo shaft is tight.
3	Check the servo cable plug connection (J6) on the main printed circuit board.	Visually examine the plug and reseal it.
4	Replace the servo plate.	Refer to the instructions included with the replacement part.
5	Call Technical Assistance Center.	1-800-423-9883 USA and Canada

**Table 9-11 Procedure #6—Troubleshooting keyboard and/or display failure symptoms**

Step	What to do	How to do it or where to find the data
1	Run a Key Test to check the operation of the keys and displays.	Refer to <i>Section 5 - Operation</i> for procedures on running a key test.
2	Replace the membrane switch (keyboard) and /or display printed circuit board as required.	Refer to the instructions included with the replacement part.

**Table 9-12 Procedure #7—Troubleshooting current proportional output failure symptoms**

Step	What to do	How to do it or where to find the data
1	Be sure the recorder is configured for current output.	Refer to <i>Section 3 - Configuration</i> . Make sure OUT ALG selection = CURRENT.
2	Check the field wiring.	Refer to <i>Section 2 - Installation</i> .
3	Be sure all the recorder and control related data is correct.	Refer to <i>Section 3 - Configuration</i> . Check the tuning, algorithm, and control data.
4	Check the output.	Put the recorder into Manual Mode and raise/lower the output manually from 0 % to 100 % (4-20 mA). Use a milliammeter at connection J1 on the control output printed circuit board.
5	Recalibrate the current proportional output.	Refer to <i>Section 8 - Output Calibration</i> .
6	Replace the control output printed circuit board.	Refer to the instructions included with the replacement part.

**Table 9-13 Procedure #8—Troubleshooting position proportional output failure symptoms**

Step	What to do	How to do it or where to find the data
1	Be sure the recorder is configured for position proportional output.	Refer to <i>Section 3 - Configuration</i> . Make sure OUT ALG selection = POSITN.
2	Check the field wiring.	Refer to <i>Section 2 - Installation</i> .
3	Check the output.	Put the recorder into manual mode and adjust the output manually to drive the motor from 0 % to 100 %.
4	Check whether the motor drives in both directions. If it does, go to step 5. If the motor drives in one direction only, check the slidewire. If the motor does not drive in either direction, check the motor.	Refer to <i>Section 8 - Output Calibration</i> for motor slidewire calibration. Refer to the motor instructions.
5	Check the output voltage to the slidewire.	Put the voltmeter across the slidewire terminals at connector J2 on the control output printed circuit board and check that the slidewire voltage varies with the motor position.
6	Be sure that the output relays are actuating properly. If they are not, check the field wiring, then go to step 4. If they are, go to step 7.	Put the recorder into manual mode and adjust the output manually above and below the present value. Listen for the click of the relays. One relay should click when the output is adjusted higher, and the other should click when the output is adjusted lower than the present value. Observe OUT 1 and 2 indicators on the front display.
7	Check the control relay jumper position.	Refer to <i>Section 3 - Configuration</i> .
8	Replace the control output printed circuit board.	Refer to the instructions included with the replacement part.
9	Recalibrate the position proportional output.	Refer to <i>Section 8 - Output Calibration</i> .

**Table 9-14 Procedure #9—Troubleshooting relay output failure symptoms**

Step	What to do	How to do it or where to find the data
1	Be sure the recorder is configured for relay output.	Refer to <i>Section 3 - Configuration</i> . Make sure OUT ALG selection = TIME.
2	Be sure all the recorder and control related data is correct.	Refer to <i>Section 3 - Configuration</i> . Check the Tuning, Algorithm, and Control data.
3	Check that the applicable output relay actuates properly. If it does, go to step 4.	Put the recorder into manual mode and adjust the output manually to raise or lower the PV around the setpoint. Listen for the click of the relay as the PV moves in either direction. Observe OUT 1 or 2 indicator on the front display.
4	Check the control relay jumper positions.	Refer to <i>Section 3 - Configuration</i> .
5	Check the field wiring.	Refer to <i>Section 2 - Installation</i> .
6	Replace the control output printed circuit board.	Refer to the instructions included with the replacement part.

**Table 9-15 Procedure #10—Troubleshooting current/time or time/current failure symptoms**

Step	What to do	How to do it or where to find the data
1	Be sure the recorder is configured for current time/time current output.	Refer to <i>Section 3 - Configuration</i> . Make sure OUT ALG selection = TI CUR or CUR TI.
2	Be sure all the recorder and control related data is correct.	Refer to <i>Section 3 - Configuration</i> . Check the tuning, algorithm, and control data.
3	Check that the applicable output relay actuates properly. If it does, go to step 4. If it does not check the field wiring; then go to step 5.	Put the recorder into manual mode and adjust the output manually to raise or lower the PV around the setpoint. Listen for the click of the relay as the PV moves in either direction. Observe OUT 1 or 2 indicator on the front display.
4	Check the control relay jumper positions.	Refer to <i>Section 3 - Configuration</i> .
5	Check the current proportional output.	Put the recorder in manual mode and manually adjust the output from 0 % to 100 % (4-20 mA). Use a milliammeter across the terminals in connector J1 on the control output printed circuit board to verify the output.
6	Recalibrate the current output.	Refer to <i>Section 8 - Output Calibration</i> .
7	Replace the control output printed circuit board.	Refer to the instructions included with the replacement part.



**Table 9-16 Procedure #11—Troubleshooting the auxiliary output**

Step	What to do	How to do it or where to find the data
1	Be sure the controller is configured for Auxiliary Output.	Refer to <i>Subsection 3.17 – Auxiliary Output Group</i> . Make sure AUX OUT is enabled and the correct parameter is chosen. Check the High and Low Scale values.
2	Check the field wiring.	Refer to <i>Section 2 – Installation</i> .
3	Check the output.	Use a milliammeter at connection J2 on the Auxiliary Output printed circuit board to determine the correct output based on your representation of 4 mA and 20 mA.
4	Recalibrate the Auxiliary Output.	Refer to <i>Subsection 8.4 – Auxiliary Output Calibration</i> .
5	Replace the Auxiliary Output printed circuit board.	Refer to the instructions included with the replacement part.

**Table 9-17 Procedure #12—Troubleshooting external alarm function failure symptoms**

Step	What to do	How to do it or where to find the data
1	Be sure all the alarm configuration data is correct.	Refer to <i>Section 3 - Configuration</i> .
2	Check the applicable alarm relay jumper position.	Refer to <i>Section 3 - Configuration</i> .
3	Check the field wiring.	Refer to <i>Section 2 - Installation</i> .
4	Check that the applicable alarm relay actuates properly depending on ALARM TYPE configuration selection.	Alarms can be triggered either by: <ul style="list-style-type: none"> <li>reconfiguring the value of the trip points (AnSnVAL), or</li> <li>connecting a signal generator to the input and setting the generator level beyond the trip-point values.</li> </ul>

**Table 9-18 Procedure #13—Troubleshooting Modbus communications**

Step	What to do	How to do it or where to find the data
1	Check the field wiring and termination resistor.	Refer to Figure 2-21 in <i>Section 2 – Installation</i> in this manual.
2	Make sure the Modbus Communications board is properly installed in the recorder.	Open the recorder door and chart plate, and inspect the board. Refer to Figure 10-4 for location of the board.
3	Run a Loopback test.	Refer to Modbus Communications manual 51-52-25-66 for loopback information.



# 10. Parts List

## 10.1 Overview

### Introduction

This section provides the replacement parts lists for the DR4500A Truline Recorder. Most parts are supplied on an optimum replacement unit basis; that is, part numbers are given for complete printed circuit boards rather than for individual PCB components.

The figures that follow are exploded views of the DR4500A recorder. Each part is labeled with a key number and the key numbers are listed in tables with associated part number.

Also included for your reference are an Internal Cabling drawing (Figure 10-5) and an Internal Wiring Diagram (Figure 10-6) for options only.

When ordering parts, be sure to specify your recorder's serial and model numbers (on nameplate) as well as the part identification.

### What's in this section?

This section contains the following topics:

Topic		See Page
10.1	Overview	245
10.2	Exploded Views	246
	Figure 10-1 Door assembly	246
	Figure 10-2 Chart plate assembly	247
	Figure 10-3 Basic recorder components without options	248
	Figure 10-4 Recorder components associated with options	250
10.3	Miscellaneous Hardware Kit Contents	252
10.4	Figure 10-5 Internal Cabling Data	253
10.5	Figure 10-6 Internal Wiring Diagram – Options Only	254

## 10.2 Exploded Views

### Door assembly

Figure 10-1 is an exploded view of the Door Assembly. Table 10-1 is a list of the associated part numbers.

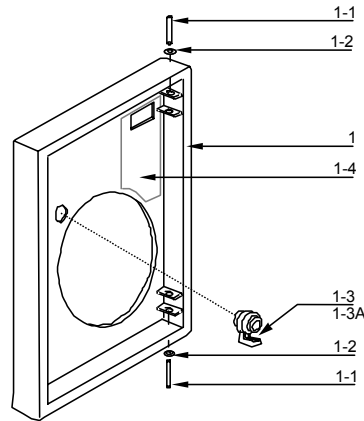

21452

**Figure 10-1 Door assembly**

**Table 10-1 Door assembly parts**

Key	Part Number	Description	Recommended Spare Parts per		Quantity per Unit
			10	100	
<b>1</b> (Note 3)	30754955-501 30754955-504 30754955-505 30754955-506 30754955-507 30754955-508 51452435-501 51452435-502 51452435-503	<b>Door Assembly</b> Blue with glass window and latch Blue with acrylic window and latch Gray with glass window and latch Gray with acrylic window and latch Black with glass window and latch Black with acrylic window and latch NEMA4X Door with Plastic window NEMA4X Door with Glass window NEMA4X Door with HTST window			1
<b>1-1</b>	(K)30755980-001	Hinge Pin (Note 1)			2
<b>1-2</b>	(K)30755980-001	Retaining Ring (Note 1)			2
<b>1-3</b> <b>1-3A</b>	51309609-503 30755980-006	Latch/Lock Assembly Kit Key kit for keyed latch or lock	1	3	1
<b>1-4</b>	30755136-502	Truline Door Overlay			1
	51404929-501	External Keypad Upgrade Kit (not shown)			1

NOTE 1: For Door 30754955-50X, (K) denotes that these parts are included in the miscellaneous hardware kit 30755980-001. For all other doors, the parts are included with applicable door assembly.

### Chart plate

Figure 10-2 is an exploded view of the Chart Plate Assembly.  
Table 10-2 is a list of the associated part numbers.

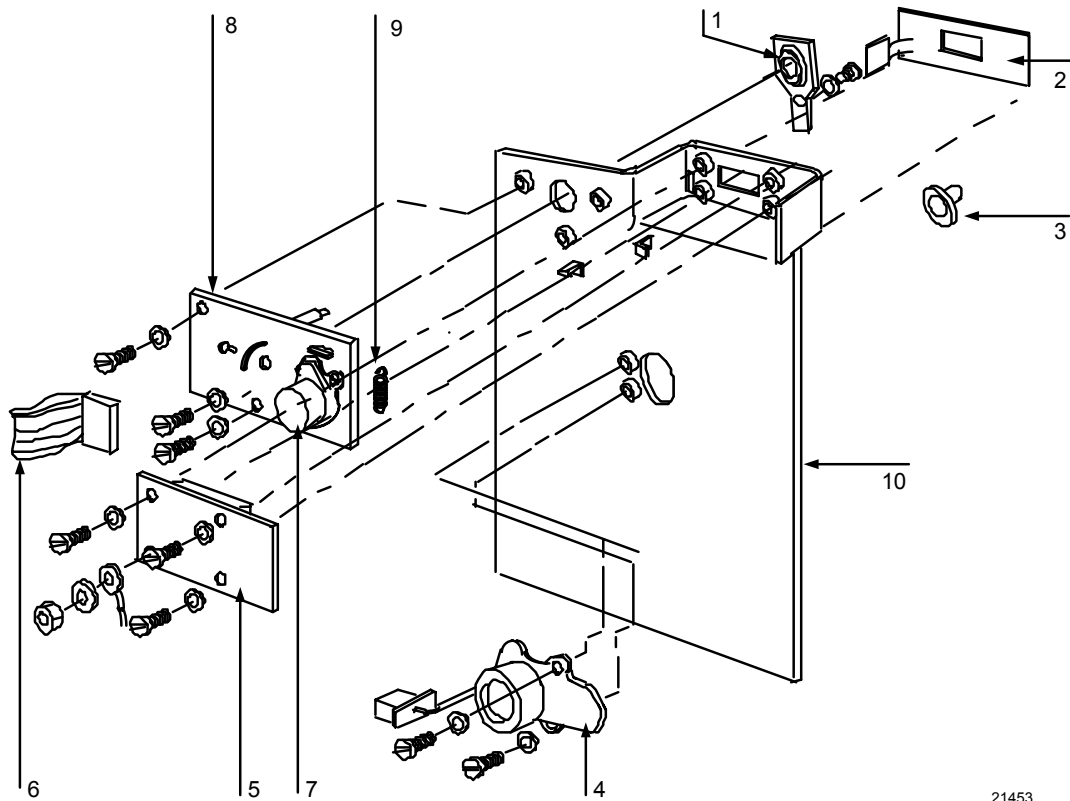

21453

**Figure 10-2 Chart plate assembly**

**Table 10-2 Chart plate assembly parts**

Key	Part Number	Description	Recommended Spare Parts per		Quantity per Unit
			10	100	
1	30756304-501	Truline Pen Arm Assembly (high speed)	1	5	1
	30756304-502	Truline Pen Arm Assembly (abrasion resistant)			
2	30754957-501	Membrane Switch Key Pad	1	5	1
3	(K)30756150-001	Chart Hub Kit	1	3	2
4	30756113-501	Chart Motor	1	3	1
5	30757571-501	Display PCB (includes key no. 6)	1	5	1
6	See above	Ribbon Cable, Display (included with key no. 5)			
7	See below	Servo Motor Assembly (included with key no. 8)			
8	30754975-503	Servo Plate Assembly (includes key no. 7)	1	2	1
9	(K)30755980-002	Spring, tension			1
10	30754977-503	Chart plate for standard (high speed) pen	1	2	1
	30754977-504	Chart plate for abrasion resistant pen			
	30754977-513	Chart plate for standard (high speed) pen - CE Mark			
	30754977-514	Chart plate for abrasion resistant pen - CE Mark			

**Basic recorder components without options**

Figure 10-3 is an exploded view of the basic recorder components.  
Table 10-3 is a list of the associated part numbers.

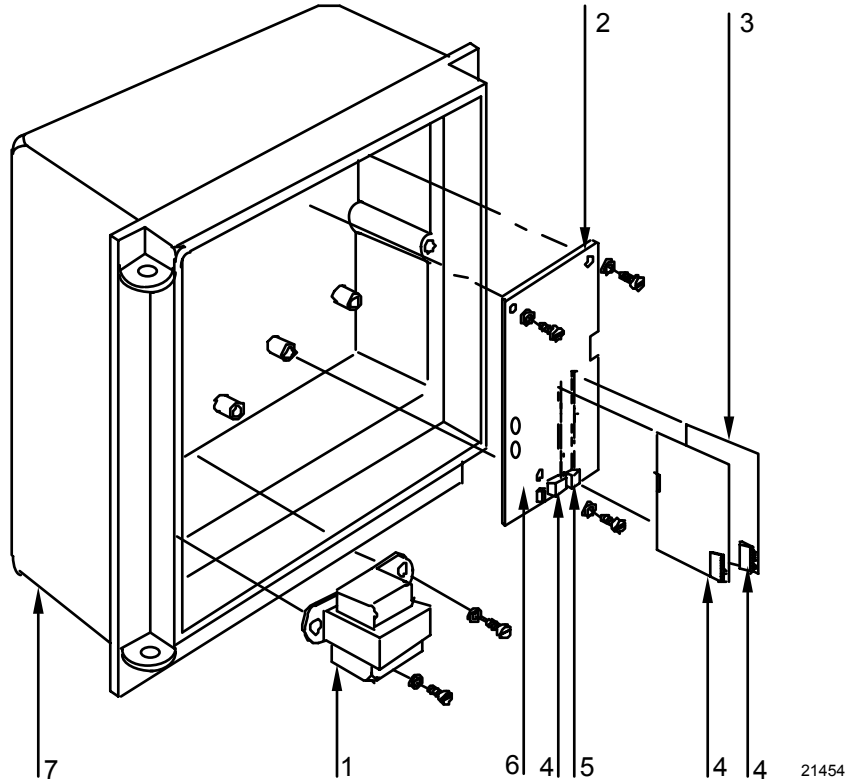

**Figure 10-3 Basic recorder components without options**

**Table 10-3 Basic recorder parts without options**

Key	Part Number	Description	Recommended Spare Parts per		Quantity per Unit
			10	100	
1	30754982-502	Main Transformer	1	3	1
2	51309355-502 51309355-503 51309355-504 51309355-505	Main PCB - CE Mark (model DR45AT) Main PCB - CE Mark (model DR45AR) Main PCB - CE Mark (model DR45AW) Main PCB - CE Mark (model DR45AH/AP/AS)	1	5	1
3	(K)30756141-003	Input PCB (input 1, 2, 3, or 4)			1/4
4	See Note 2	3-position connector**			2
5	See Note 2	2-position connector**			1
6	30755980-005	Fuse (Wilkman 19374-K-500 ohm or equal)**			1
7	30754924-502	Case			1
<b>PARTS NOT SHOWN</b>					
	See Note 2	Card guides for Input PCBs**			2
	51197612-502 51197612-508	Ferrite Filter - Package of 2 (CE Mark) Ferrite Filter - Package of 8 (CE Mark)			1
	51197650-501	Washer Kit (package of 6)			1
	51197755-001	Capacitor Kit (.01mfd) - 12 per kit (CE Mark)			
	30755232-502	0-10 Vdc Input Divider (input PCBs)			*
	30756461-002	250 ohm Resistor Assembly			*
	30755317-001	Box of 100 12" Truline Chart Paper			
	(K)30755065-501 (K)30755065-503	Mounting Kit (standard) Mounting Kit (NEMA4X)			1
	(K)30755134-001 (K)30755134-002	Blue Universal Filler Plate Kit Gray Universal Filler Plate Kit			*
	(K)30755011-001	Filler Panel Kit (for replacing Servoline recorder)			*
	(K)30757301-001	Configuration Lockout Hardware			1
	51197657-501	DR4300/DR4500 Panel Gasket			1
	51198150-501	Pipe Mounting Kit 2" Pipe Size			1
	51197657-501 51197657-502	Panel Mounting Gasket Kit (standard) Panel Mounting Gasket Kit (NEMA4X)			1

NOTE 2: These parts are included with applicable PCB kits, as required.

\* As required

\*\* These parts are also included in the miscellaneous hardware kit 30755980-006

**Additional recorder components associated with options**

Figure 10-4 is an exploded view of the recorder components associated with options.  
Table 10-4 is a list of the associated part numbers.

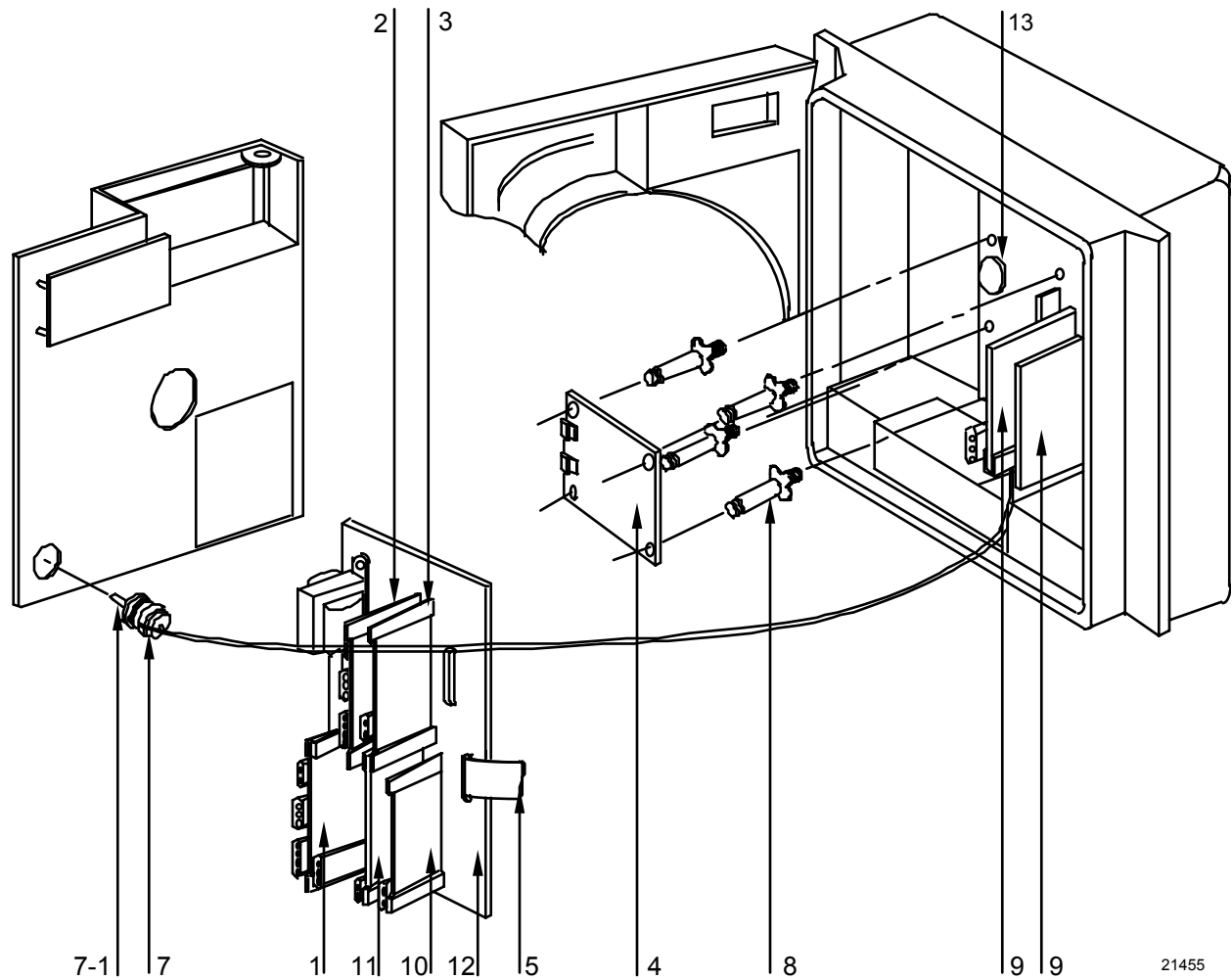

21455

**Figure 10-4 Recorder components associated with options**



**Table 10-4 Recorder parts associated with options**

Key	Part Number	Description	Recommended Spare Parts per		Quantity per Unit
			10	100	
1	30754922-501 30754922-502	Second Control Output PCB Second Current Output PCB - Current Out Only (Note 4)			1
2	30754922-501 30754922-502	First Control Output PCB First Control Output - PCB - Current Out Only	1	5	1
	30754499-005	Control Output Relay Kit (2 relays per kit)	1	5	2
3	51404561-501 51404561-502 51404561-503	Auxiliary Output PCB (includes terminal blocks and card guides as required) RS485 Modbus RTU Communications PCB RS485 Modbus RTU plus Auxiliary Output PCB	1	5	1
4	(K)30756140-001	Alarm output/digital input PCB kit			1
5	See Note 3 30755119-501	Ribbon cable (34 conductor)	1	3	1
7	30755127-502	Light accessory kit			1
7-1	(K)30749598-501	Kit of 5 Bulbs (General Instruments 1828 or equivalent)			1
8	(K)30756140-001	Spacers			4
9, 10, 11	(K)30756141-003	Input PCBs (1, 2, 3, or 4)	1	5	1/4
12	30754919-501	Mother board	1	3	0/1
13	30755980-004	Battery (Duracell DL2450 or equivalent)	1	1	1

NOTE 3: Part included with alarm output/digital input PCB kit 30756140-001.

NOTE 4: 30754922-502 Control Output board is used for Table II Options 60 or 66.

## 10.3 Miscellaneous Hardware Kit Contents

### Kit contents

Table 10-5 lists the kit contents of miscellaneous hardware kit — part number 30755980-TAB.

**Table 10-5 Miscellaneous hardware kit**

Part Description	Quantity					
	Tab 001	Tab 002	Tab 003	Tab 004	Tab 005	Tab 006
Pen lifter/retainer		1				
Screw 10-32, 3/4" lg.		5				
O-ring		5				
Spring, tension		2				
Hinge pin	2					
Retaining ring	2					
Pen arm #1 (classic)		1				
Pen arm #2 (classic)		1				
Latch without lock	1					
Latch pin	1					
Latch gasket	1					
Card guide			2			
4-position connector			2			
3-position connector			2			
3-position connector—CE Mark			2			
2-position connector			2			
Fuse 0.5 A, 250 V					20	
Batteries 3.0 V Lithium Button Cell				5		
Key for latch or lock						1
Key for Door/Keyed latch						1

## 10.4 Internal Cabling Data

### View of internal cabling

Figure 10-5 is a view of the internal cabling for the DR4500A Truline Recorder.

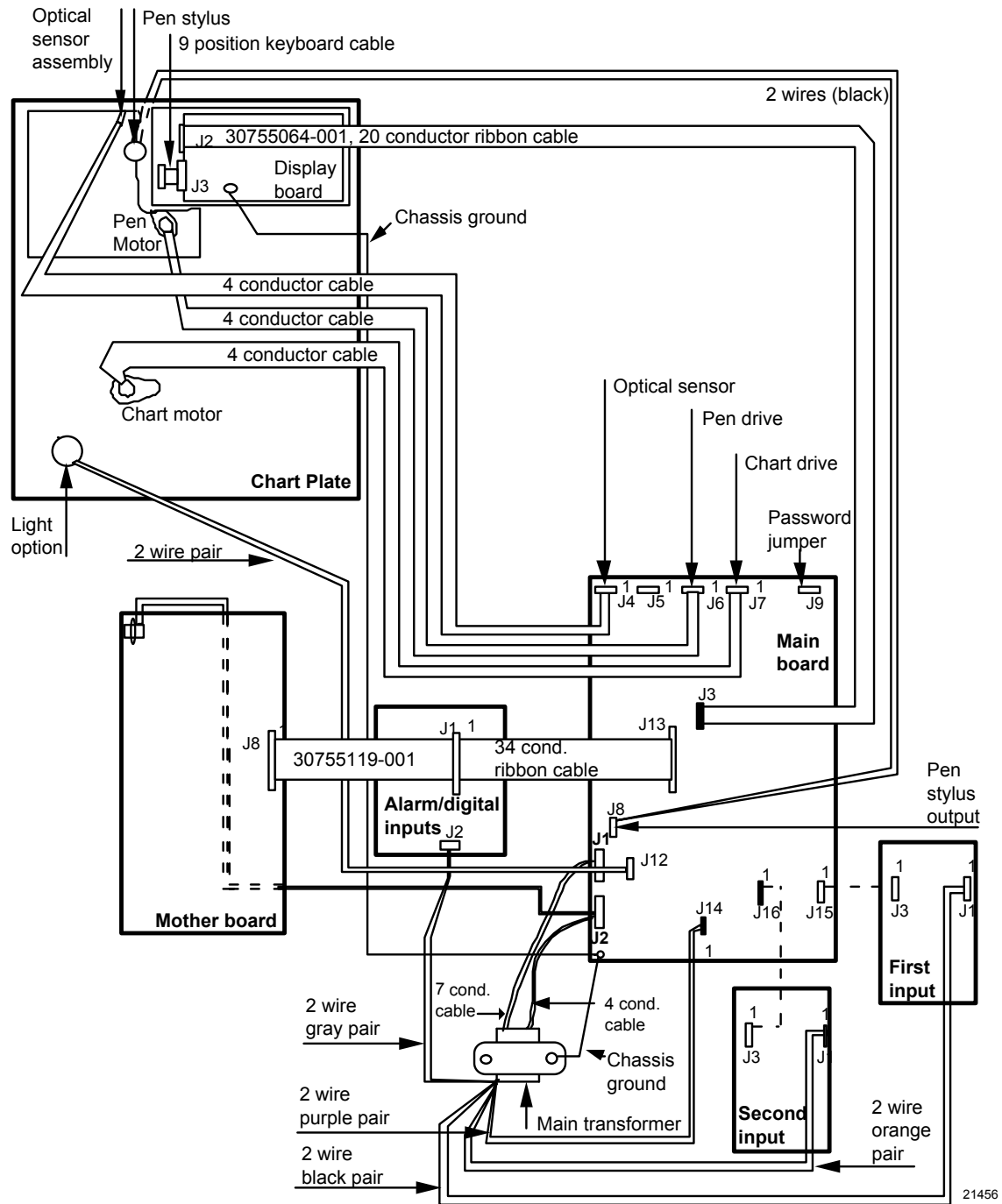

Figure 10-5 Internal cabling for DR4500A Truline recorder

## 10.5 Internal Wiring Diagram – Options Only

### View of internal option wiring

Figure 10-6 is a view of the internal wiring diagram - options only for the DR4500A Truline Recorder.

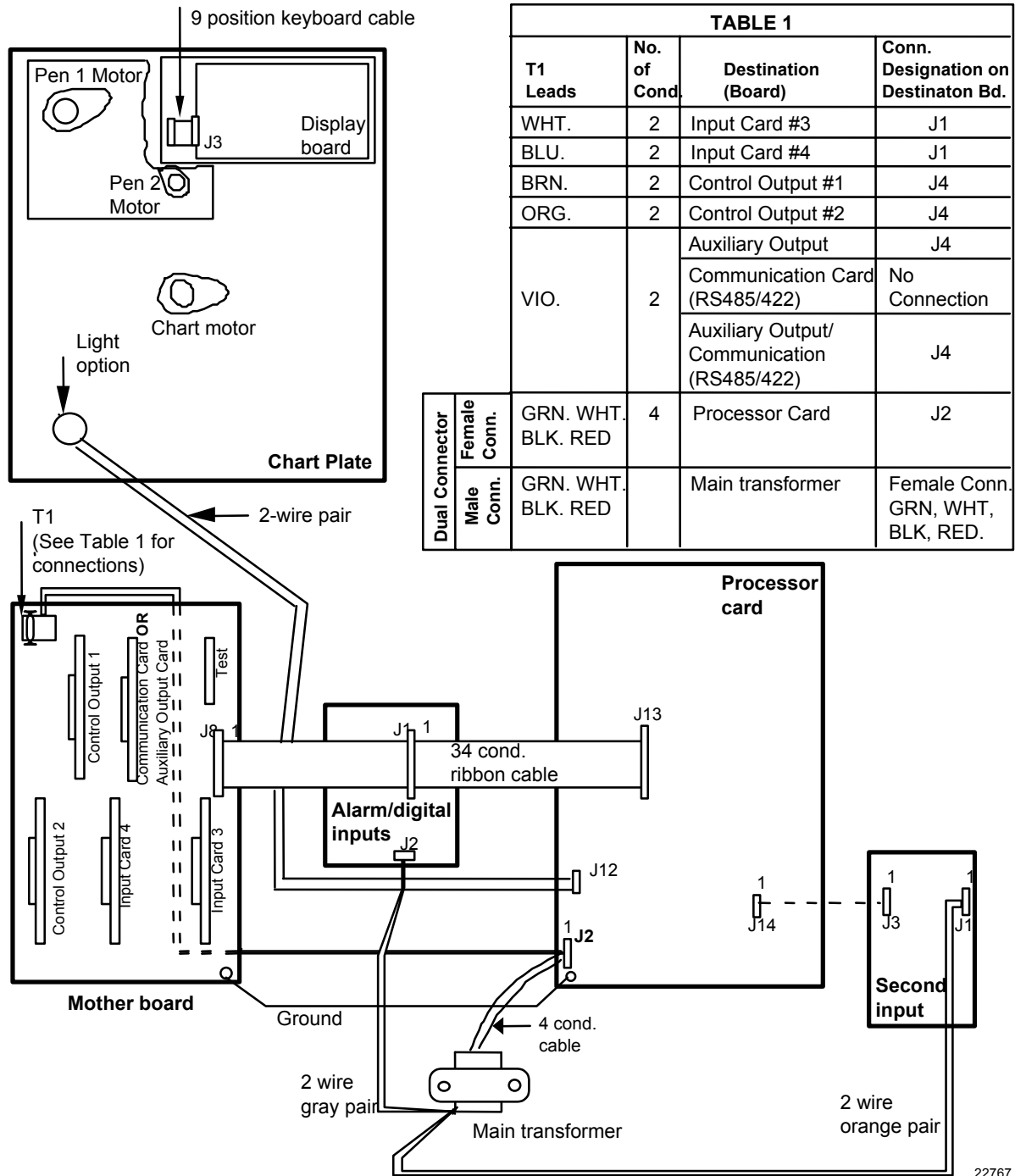

Figure 10-6 Internal diagram for DR4500A Truline recorder – options only

# A. Model DR45AR

## A.1 Overview

### Introduction

If the key number for your recorder is DR45AR, it is a relay expansion model Truline recorder that can have up to six alarm relay outputs and include Fo calculation function. While its basic functions are identical to the standard (DR45AT) Truline recorder, it does have some unique hardware, wiring and configuration features. This section provides the data pertinent to these unique features as a supplement to the standard Truline in this product manual.

### What's in this section?

The table below lists the topics that are covered in this section.

Topic		See Page
A.1	Overview	255
A.2	Hardware Identification	256
A.3	Fo Reset Configuration	258
A.4	Options Configuration	259
A.5	Operations Additions	261
A.6	Configuration Worksheet Additions	262

## A.2 Hardware Identification

### Introduction

Figure A-1 (DR45AR with one input) and Figure A-2 (DR45AR with two to four inputs) identify the hardware components of the DR45AR model versus "Table" selections.

### DR45AR with one input

Figure A-1 identifies the hardware components of the DR45AR with one input.

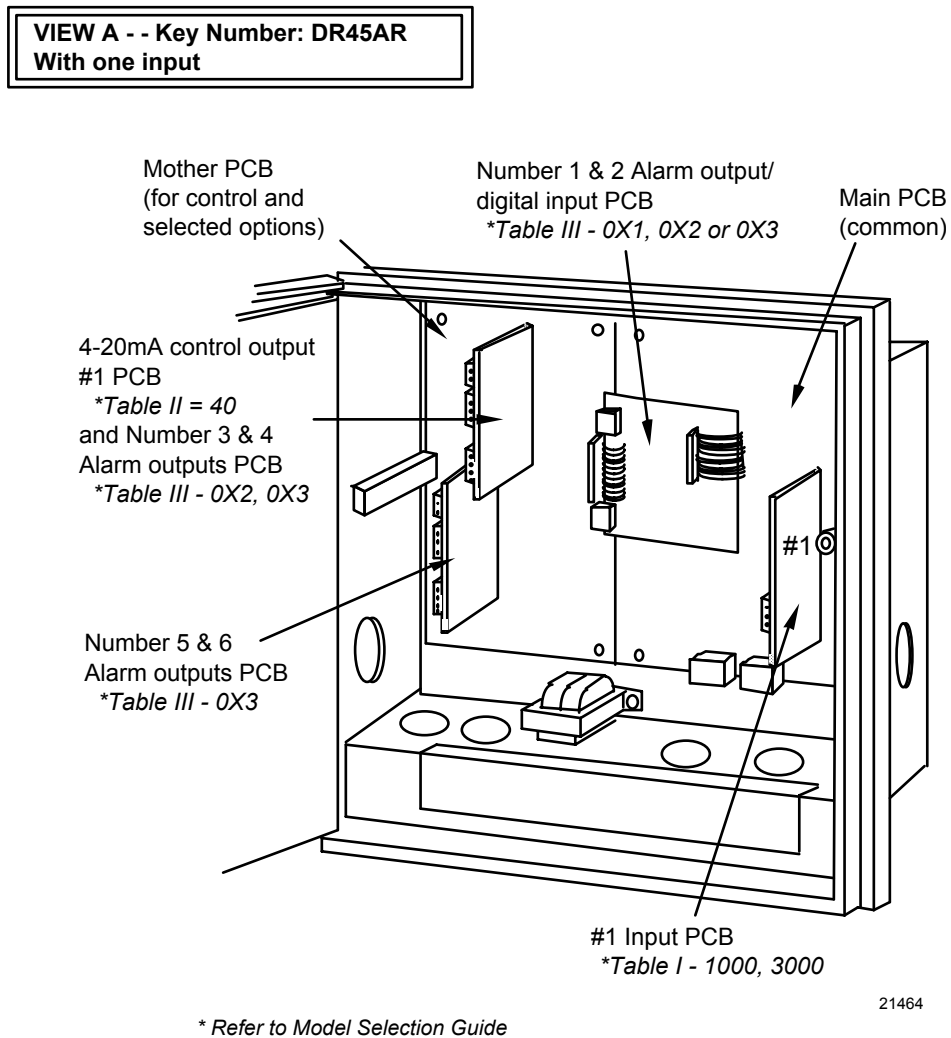

**Figure A-1 DR45AR with one input**

**DR45AR with two to four inputs**

Figure A-2 identifies the hardware components of the DR45AR with two to four inputs.

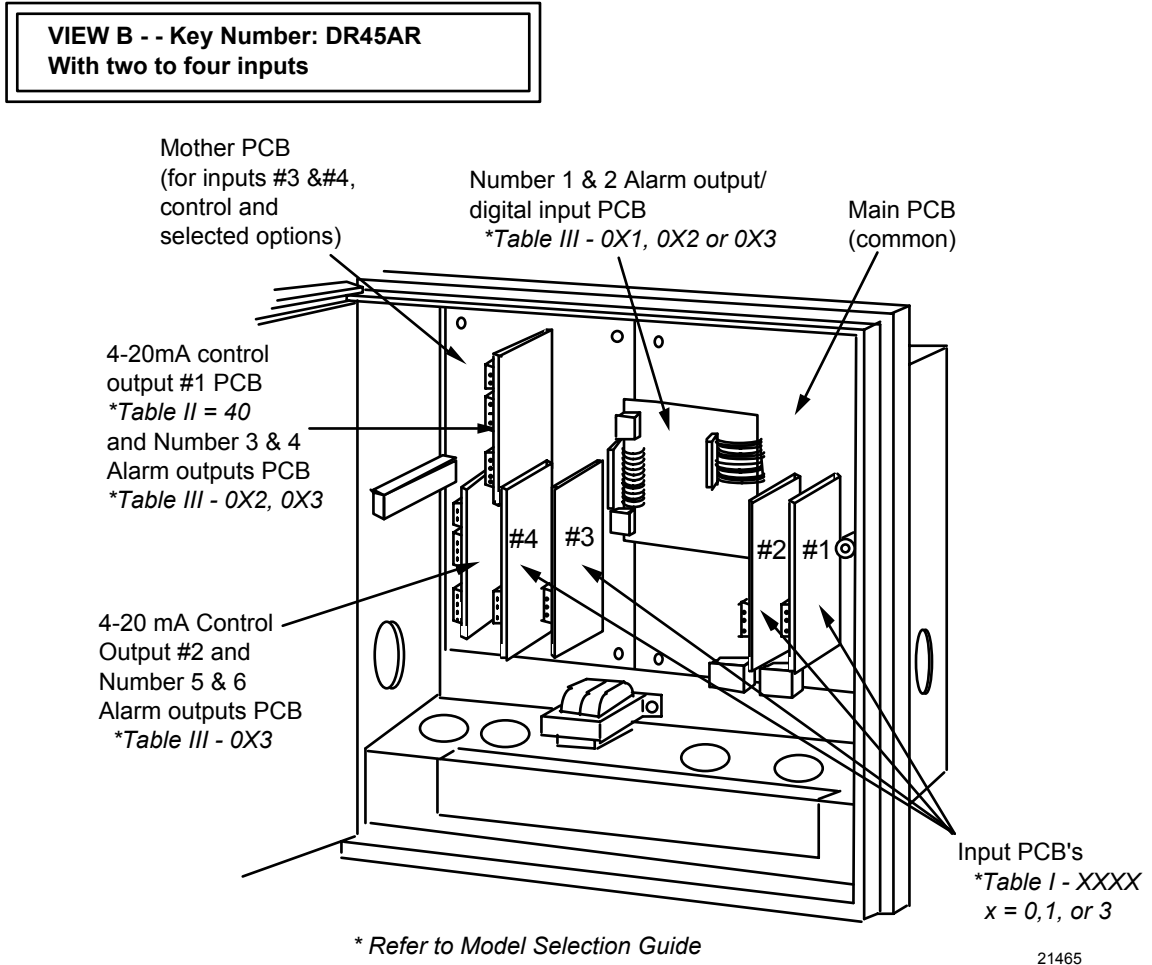

**Figure A-2 DR45AR with two to four inputs**

## A.3 Fo Reset Configuration

### Introduction

This SET UP group is specific to Model DR45AR. It allows you to reset the Fo sterilization calculation.

### Accessing Fo reset prompts

Press the **SET UP** key until you see:

*Upper Display:* **SET UP**

*Lower Display:* **FO RESET**

Press the **FUNC** key to call up the Fo Reset function prompt that will allow you to reset the Fo sterilization calculation. The function prompt for the Fo Reset group is listed in Table A-1.

### Function prompts

Table A-1 lists the function prompt in the "Fo RESET" Set Up group for model DR45AR.

**Table A-1 Fo RESET group function prompts**

<b>Function Prompt Lower Display</b>	<b>Function Name</b>	<b>Selections or Range of Setting Upper Display</b>	<b>Factory Setting</b>
<b>RESET Fo</b>	Reset Fo Sterilization Calculation  (REM SW or REM SW2 under "OPTIONS" group must be configured for "FO RST".)	NO YES	



## A.4 Options Configuration

### Introduction

For Model DR45AR there are several additions to be added to Table 3-17 Options Group Function Prompts (from Section 3). They cover additional options that are only available with this model number.

Table A-3 on the next page shows the additions made for Model DR45AR in the options group definitions.

**Table A-2 Options group function prompts, continued from Section 3/Table 3-17**

Function Prompt Lower Display	Function Name	Selections or Range of Setting Upper Display	Factory Setting
<b>STERILIZ</b>	Fo Sterilization Time	YES NO	
<b>IN TEMP</b>	Input for Product Temperature	INPUT 1 INPUT 2 INPUT 3 INPUT 4	
<b>STDTEMP</b>	Standard Reference Temperature	0.1 to 9999	
<b>Z VALUE</b>	Thermal Resistance	0.1 to 9999	
<b>REM SW</b>	Remote Switching	NONE TO MAN (from AUTO) TO LSP (from REMOTE) TO 2SP (from LSP) TO DIR (from REV) TO HOLD (from RUN) TUNE FO RST	
<b>REM SW2</b>	Remote Switching — digital input 2	NONE FO RST	

**Table A-3 Option group definitions, continued from Section 4/Table 4-15**

Lower Display Prompt	Upper Display Range of Setting or Selection	Parameter Definition
<b>STERILIZ</b>	YES (activates Fo sterilization calculation) NO	<p><b>Fo STERILIZATION TIME</b> — This function computes equivalent sterilization time by accumulating lethality rates for a product over each 1/3 or 2/3 second scan interval of the recorder using this equation:</p> $T_s = T_{s(t-1)} + dt \times 10^{\frac{(t-T_b)}{z}}$ <p><i>Where:</i>            T<sub>s</sub> = sterilization time in minutes            T<sub>s(t-1)</sub> = previous sterilization time            dt = time interval (1/3 or 2/3 second)</p> <p>NOTE: 1/3 second if less than 3 configured inputs; 2/3 second if greater than 2 configured inputs.</p> <p>T<sub>b</sub> = standard reference temperature (configurable)            t = product (input) temperature (°F or °C)            z = thermal resistance (configurable)</p> <p>Only applicable if Model Table II is 40, Model Table III is 0X3, and Model Table IV is F.</p>
<b>INTEMP</b>	INPUT 1 INPUT 2 INPUT 3 INPUT 4	<b>INPUT FOR PRODUCT TEMPERATURE</b> — selects which input will supply product temperature for sterilization calculation.
<b>STDTEMP</b>	0.1 to 9999	<b>STANDARD REFERENCE TEMPERATURE</b> — selects a reference temperature constant for sterilization calculation — usually 250 °F or 121 °C.
<b>Z VALUE</b>	0.1 to 9999	<b>THERMAL RESISTANCE</b> — selects a thermal resistance constant for sterilization calculation — usually 18 °F or 10 °C.
<b>REM SW</b>	NONE TO MAN (from AUTO) TO LSP (from REMOTE) TO 2SP (from LSP) TO DIR (from REV) TO HOLD (from RUN) TUNE FO RST	<p><b>REMOTE SWITCHING</b> — allows you to select an action to be initiated by remote contact closure through digital input .</p> <p>NONE — No Selection            TO MAN — switch to manual mode from automatic            TO LSP — switch to local setpoint from remote            TO 2SP — switch to 2nd setpoint from local setpoint            TO DIR — switch to direct output action from reverse            TO HOLD — put ramp/soak program in hold            TUNE — start Accutune            FO RST — reset sterilization calculation.</p>
<b>REM SW2</b>	NONE FO RST	<b>REMOTE SWITCHING DIGITAL 2 INPUT</b> — allows you to select remote contact closure through digital 2 input to reset sterilization calculation or not.

## A.5 Operations Additions

### Introduction

In addition to the standard operating functions in this manual the addition listed below appears if you have model DR45AR.

### Viewing F<sub>O</sub> sterilization display

Add the following prompt to Table 5-5 Lower Display Key Parameter Prompts.

Prompt	Description
F <sub>O</sub>	F <sub>O</sub> sterilization time in the lower display with the appropriate input in the upper display

### Digital input (REM SW) prompt selection

Add the following selections to Table 5-25 Digital Input Option Action on Contact Closure.

REM SW Selections	Display Indication	Action on Contact Closure
F <sub>O</sub> RST	None	Resets F <sub>O</sub> sterilization calculation — if F <sub>O</sub> RESET prompt is enabled.

## A.6 Configuration Worksheet Additions

### Configuration additions

In addition to the Configuration worksheet items that are listed in *Section 3 - Configuration*, the following parameters also appear in Model DR45AR.

Group Prompt	Function prompt	Value or Selection	Factory Setting
<b>FO RESET</b>	RESET FO	_____	
<b>OPTIONS</b>	REJ FREQ	_____	60
	HF REJ	_____	ENABLE
	RELHUMID	_____	NO
	ATMPRES	_____	—
	DEVIATION	_____	NONE
	DEVSETPT	_____	0
	SCROLL	_____	NONE
	GRANDTOT	_____	DISABL
	STERILIZ	_____	
	IN TEMP	_____	
	STDTEMP	_____	
	Z VALUE	_____	
	REM SW	_____	
	REM SW2	_____	

## B. Security Lockout

### B.1 Overview

#### Introduction

Your recorder has a security bypass code which allows you to enter secured areas if you have forgotten or lost the operator security code.

To use the universal password, go to the Lockout Set Up group. At PASSWORD enter 1502. This overrides the existing password.

Be sure to re-enter a new password to lockout any unauthorized changes to the recorder's configuration and calibration prompts.



#### **ATTENTION**

**Remove this page for security.**

---



## **C. Foreign Language Safety Instructions**

## SIKKERHESKRAV

DA2I-6056



For at undgå elektrisk stød med mulighed for personskade, skal alle sikkerhedsbestemmelser i denne manual følges nøje.



Dette symbol advarer brugeren om en potentiel berøringsfare, såfremt der kan være adgang til den livsfarlige netspænding.

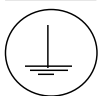

Beskyttende jordterminal. Terminalen er forberedt for og skal forbindes til beskyttelsesjordledning i henhold til stærkstrømsberkendtgørelsen (DK).

- Hvis udstyret ikke bruges som specificeret i manualen, kan den beskyttelse udstyret yder blive nedsat eller forsvinde.
- Eerstat kun komponenter som udtrykkeligt er specificeret som udskiftelige i manualen.
- Alle ledningsforbindelser skal følge stærkstrømsberkendtgørelsen (DK) og udføres af autoriseret erfarent personel.
- Den beskyttende jordterminal skal forbindes først af alle forbindelser (og fjernes som den sidste).
- Det anbefales jvf. stærkstrømsberkendtgørelsen, at der installeres en afbryder til frosyningspændingen nær udstyret.

### UDSTYRS SPECIFIKATIONER

Strømforsyning	102 til 132 Vac - 204 til 264 Vac
Frekvens	50 – 60 Hz
Nominel effekt	20 watts max.

### OMGIVELSES SPECIFIKATIONER

Placer ikke udstyret i nærheden af brandbare væsker eller dampe.

Temperatur	Rumtemperatur : 0 til 55°C
Fugtighed	5 til 90% RH - 40°C
Vibration	0 til 200 Hz acceleration 0.2 g

### UDSTYRS INSTALLATION

Skriveren skal monteres i en tavle for at forhindre adgang til bagterminaler.



## VEILIGHEIDSVEREISTEN

DU21-6056



Ter vermindering van het gevaar van elektrische schokken die lichamelijk letsel kunnen veroorzaken, dient u alle veiligheidsaanwijzingen in dit document te volgen.



Dit symbool waarschuwt de gebruiker voor een potentieel schokgevaar wanneer toegang bestaat tot onderdelen die onder gevaarlijke spanning staan.

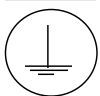

Beschermende aarde-aansluiting. Bestemd voor aansluiting van de aardingsdraad van de voeding.

- Indien de apparatuur wordt gebruikt anders dan door de fabrikant gespecificeerd, kan de bescherming, die de apparatuur biedt ongedaan worden gemaakt.
- Alleen die onderdelen mogen worden vervangen die door de fabrikant als uitwisselbaar zijn aangemerkt.
- Alle bedrading moet in overeenstemming zijn met de lokale elektriciteiseisen en moet aangelegd worden door geautoriseerd, ervaren personeel.
- De aardingsdraad moet worden aangesloten vóórdat alle andere bedrading wordt aangesloten (en als laatste worden verbroken).
- Het verdient aanbeveling een netschakelaar aan te brengen vlakbij het instrument.

### **APPARATUUR VOORWAARDEN**

Voedingsspanning	102 tot 132 Vac - 204 to 264 Vac
Frequentie	50 – 60 Hz
Vermogen of stroomvermogen	20 watts max.

### **OMGEVINGSCONDITIES**

Gebruik het instrument niet in de aanwezigheid van ontvlambare vloeistoffen of dampen. Het gebruik van elk elektrisch instrument in een dergelijke omgeving vormt een gevaar voor uw veiligheid.

Temperatuur	In bedrijf : 0 tot 55°C
Vochtigheid	5 tot 90% RH - 40°C
Trilling	0 tot 200 Hz versnelling 0.2 g

### **MONTAGE VAN DE APPARATUUR**

De recorder moet worden gemonteerd in een paneel om de toegankelijkheid tot de achterste aansluitpunten te beperken.

## TURVALLISUUSMÄÄRÄYKSET

FI2I-6056



Noudata tämän ohjeen kaikkia turvaohjeita välttääksesi sähkötapaturman vaaraa.



Tämä merkki varoittaa käyttäjää sähköiskun vaarasta paikassa, missä voi koskettaa vaarallisia jännitteitä.



Suojamaaliitin. Kytke maadoitsjohdin tähän liittimeen.

- Jos laitetta käytetään olosuhteissa, joihin sitä ei ole suunniteltu, käyttöturvallisuus voi heikentyä.
- Älä vaihda mitään komponenttia tai osaa, jota valmistaja ei ole määritellyt käyttäjän vaihdettavaksi.
- Asennus ja johdotus on tehtävä paikallisten varuusmääräysten mukaisesti valtuutetun sähköasentajan toimesta.
- Ensimmäiseksi on kytkettävä suojamaa-liitin (ja viimeiseksi irroitettava).
- Laitteen läheisyyteen suositellaan asennettavaksi verkkokytkin.

### LAITTEEN VAATIMUKSET

Syöttöjännite	102 - 132 Vac / 204 - 264 Vac
Taajuus	50 – 60 Hz
Teho	20 watts

### KÄYTTÖOLOSUHTEET

Älä käytä laitetta paikassa jossa on syttyviä nesteitä tai kaasuja, koska laitteen käyttö aiheuttaa räjähdysvaaran.

Lämpötila	ympäröivä : 0 ... 55°C
Kosteus	5 ... 90% RH - 40°C
Tärinä	0 ... 200 Hz
	Kiihtyvyys 0.2 g

### LAITTEEN ASENNUS

Piirturi on asennettava paneeliin siten, että peräliitimille jää riittävästi tilaa.

## CONSIGNES DE SECURITE

FR2I-6056



Pour réduire tout risque de décharge électrique qui pourrait provoquer une lésion corporelle, respectez toutes les consignes de sécurité de cette documentation.



Ce symbole avertit l'utilisateur d'un risque électrique potentiel lorsqu'il peut avoir accès à des éléments sous tension.



Borne de mise à la terre. Destinée au raccordement du conducteur de mise à la terre de l'alimentation.

- Si l'équipement est utilisé dans un but non spécifié par le constructeur, la protection fournie avec cet équipement peut être affectée.
- Aucun composant (ou pièce) ne doit être remplacé s'il n'est pas explicitement spécifié comme tel par le constructeur.
- Tous les câblages doivent être conformes aux normes locales et doivent être réalisés par un personnel autorisé et expérimenté.
- La borne de masse doit être raccordée avant tout autre câblage (et débranchée en dernier).
- Il est obligatoire de connecter cet appareil sur une ligne possédant un moyen de coupure près de l'appareil.

### **CARACTERISTIQUES DE L'EQUIPEMENT**

Tension d'alimentation	102 à 132 Vac ou 204 à 264 Vca
Fréquence	50 – 60 Hz
Puissance ou courant	20 watts max.

### **CONDITIONS AMBIANTES**

Ne jamais utiliser cet équipement en présence de liquides ou vapeurs inflammables.

L'utilisation de tout instrument électrique dans un tel environnement pourrait présenter un risque pour la sécurité.

Température	Ambiante : 0 à 55°C
Humidité	5 à 90 % HR à 40°C
Vibration	Fréquence : 0 à 200 Hz Accélération 0.2 g

### **INSTALLATION DE L'EQUIPEMENT**

Cet appareil doit être monté dans un panneau pour limiter l'accès aux bornes arrières par l'opérateur.

## SICHERHEITSHINWEISE

GE2I-6056



Befolgen Sie alle Sicherheitshinweise in diesen Unterlagen, um das Risiko eines Stromschlags zu verringern, der zu Körperverletzung führen kann.



Dieses Symbol warnt den Benutzer vor eventueller Berührungsfahr, wo lebensgefährliche Spannungen zugänglich sein können.

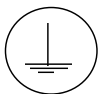

Schützende Erdung. Für den Anschluß der schützenden Erdung der Versorgungssystemleitung.

- Bei Benutzung der Ausrüstungen auf nicht vom Hersteller angegebene Art und Weise kann der von der Ausrüstung gewährleistete Schutz beeinträchtigt werden.
- Ersetzen Sie keine Komponente (oder Teil), die/das nicht ausdrücklich vom Lieferanten als ersetzbar angegeben ist.
- Die gesamte Verkabelung muß den örtlichen Normen entsprechen und von zugelassenem, erfahrenem Personal durchgeführt werden.
- Die Erde muß vor allen anderen Kabeln angeschlossen (und zuletzt abgeklemmt) werden.
- In der Nähe der Ausrüstung muß ein Schalter in der Hauptstromversorgung vorhanden sein.

### **AUSRÜSTUNGSDATEN**

Netzspannung 102 bis 132 Vac oder 204 bis 264 Vac  
Frequenz 50 – 60 Hz  
Nennleistung 20 watts max.

### **UMGEBUNGSBEDINGUNGEN**

Betreiben Sie das Gerät nicht in Gegenwart entflammbarer Flüssigkeiten oder Dämpfe. Der Betrieb elektrischer Geräte in solchen Umgebungen stellt ein Sicherheitsrisiko dar.

Temperatur Umgebung : 0 bis 55°C  
Feuchtigkeit 5 bis 90% RH - 40°C  
Vibration 0 bis 200 Hz  
Beschleunigung 0.2 g

### **ANBRINGUNG DER AUSRÜSTUNGEN**

Der Regler muß in ein Pult eingebaut sein, damit der Bediener nicht zu oft auf die hinteren Anschlüsse zugreifen muß.

**GR2I-6056**

## **NORME DI SICUREZZA**

**IT21-6056**



Per ridurre i rischi di scariche elettriche che potrebbero causare alle persone, seguire tutte le precauzioni circa la sicurezza indicate in questa documentazione.



Questo simbolo avverte del pericolo di scossa elettrica nelle aree in cui sono accessibili conduttori sotto tensione.



Terminale di protezione verso terra. Previsto per il collegamento del conduttore di protezione verso terra del sistema di alimentazione.

- Se lo strumento viene utilizzato in modo diverso dalla specifica del costruttore, la protezione fornita dallo strumento può essere diversa.
- Non sostituire alcun componente (o parte) non specificato esplicitamente come ricambio dal vostro fornitore.
- Tutti i cablaggi devono essere in accordo con i regolamenti locali e devono essere eseguiti da personale esperto ed autorizzato.
- Il terminale di massa deve essere collegato prima di ogni altro filo (e scollegato per ultimo).
- E necessario che sia presente un interruttore nell'alimentazione principale accanto all'apparecchio.

### **ALIMENTAZIONE APPARECCHIATURA**

Tensione di alimentazione Da 102 a 132 Vac ó da 204 a 264 Vac  
Frequenza 50 – 60 Hz  
Potenza o corrente 20 watts max.

### **CONDIZIONI AMBIENTALI**

Non far funzionare l'apparecchio in presenza di liquidi o gas infiammabili, in quanto questo potrebbe essere estremamente pericoloso.

Temperatura Ambiente : da 0 a 55°C  
Umidità relativa Da 5 a 90% UR a 40°C  
Vibrazioni Da 0 a 200 Hz  
accelerazione 0.2 g

### **INSTALLAZIONE DELL'APPARECCHIO**

Il apparecchio deve essere montato su un pannello per limitare l'accesso ai terminali posteriori.

## SIKKERHETSKRAV

NO2I-6056



Følg alle retningslinjene i dette dokumentet, slik at du reduserer risikoen for elektrisk støt og mulige personskader.

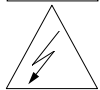

Dette symbolet advarer brukeren om tilgjengelige terminaler med farlige spenninger og en potensiell fare for elektrisk støt.

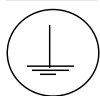

Jordingsterminal. kablen for jording av systemet skal tilknyttes til denne terminalen.

- Dersom utstyret benyttes på en måte annerledes enn spesifisert av produsent, kan utstyrets beskyttelsesgrad forringes.
- Ingen komponenter eller deler skal skiftes ut dersom de ikke er uttrykkelig spesifisert som utskiftbare av din forhandler.
- Det er påkrevet med en hovedstrømsbryter i nærheten av utstyret.
- All kabling må utføres i henhold til gjeldende forskrifter og installeres av autoriser og erfaren installatør.
- Jord må tilknyttes før all annen kabling (og frakobles sist).

### UTSTYRSPESIFIKASJONER

Strømtilførsel	102 til 132 Vac - 204 til 264 Vac
Nettfrekvens	50 – 60 Hz
Kraftforbruk	20 watts max.

### OMGIVELSER

Instrumentet må ikke opereres i nærheten av lettantennelige væsker eller gasser. Bruk av elektriske instrumenter i slike omgivelser utgjør en sikkerhetsrisiko.

Temperatur	omgivelse : 0 til 55°C
Fuktighet	5 til 90% HR - 40°C
Vibrasjon	0 til 200 Hz akselerasjon 0.2 g

### UTSTYRSINSTALLASJON

Pass på å montere panelene på regulatoren, slik at berøring av terminalene på baksiden forhindres.

## INSTRUÇÕES DE SEGURANÇA

**PO2I-6056**



Para reduzir o risco de choque eléctrico que pode causar danos corporais, seguir todas as normas de segurança contidas nesta documentação.



Este símbolo avisa o utilizador sobre um eventual perigo de choque quando são acessíveis voltagens sob tensão perigosas.

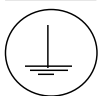

Terminal de protecção de terra. Fornecido para ligação do condutor do sistema da protecção de terra.

- Se este equipamento for usado de modo não especificado pelo fabricante, a protecção fornecida pelo equipamento pode não ser adequada.
- Não se deve substituir qualquer componente (ou peça) que não seja explicitamente especificado como substituível pelo nosso revendedor.
- Toda a cablagem deve estar de acordo com os códigos eléctricos locais e deve ser realizada por pessoal experiente devidamente autorizado.
- O terminal de terra deve ser ligado antes de ser feita qualquer outra cablagem (e desligado em último lugar).
- Recomenda-se um comutador na fonte de alimentação principal próximo do equipamento.

### **ESPECIFICAÇÕES DO EQUIPAMENTO**

Voltagem	102 a 132 Vac - 204 a 264 Vac
Frequência	50 – 60 Hz
Potência ou consumo de corrente	20 Watts max.

### **CONDIÇÕES AMBIENTAIS**

Não operar o instrumento na presença de líquidos ou vapores inflamáveis. A operação de qualquer instrumento eléctrico em tal ambiente constitui um perigo para a segurança.

Temperatura	Ambiente : 0 a 55°C
Humidade	5 a 90% RH a 40°C
Vibração	0 a 200 Hz aceleração 0.2 g

### **INSTALAÇÃO DO EQUIPAMENTO**

O Registrador deve ser montado num painel para limitar o acesso do operador aos terminais traseiros.



## **NORMAS DE SEGURIDAD**

**SP2I-6056**



Para reducir el riesgo de choque eléctrico el cual podría causar lesiones personales, seguir todas las indicaciones de este documento.



Este símbolo previene al usuario de un riesgo potencial de descarga cuando se puede acceder a corrientes de tensión peligrosas.



Terminal de tierra de protección. Proporcionado para la conexión de la tierra de protección del conductor del sistema de alimentación.

- Si el equipo es utilizado de forma no especificada por el fabricante, la protección suministrada con el mismo podría resultar dañada.
- No reemplazar ningún componente (o parte) no explícitamente especificado por el suministrador.
- Todo el cableado debe realizarse de acuerdo con las normas eléctricas locales y debe ser realizado por personal experimentado.
- El terminal de tierra debe ser conectado antes que cualquier otro cable y desconectado el último.
- Se recomienda la instalación de un interruptor de la alimentación principal, cerca del equipo.

### **DATOS ELECTRICOS DEL EQUIPO**

Tensión de alimentación 102 a 132 Vac - 204 a 264 Vac  
Frecuencia 50 – 60 Hz  
Potencia o corriente 20 watts max.

### **CONDICIONES AMBIENTALES**

No operar con el instrumento en presencia de líquidos o gases inflamables. La operación de cualquier equipo eléctrico en tal ambiente constituye un riesgo contra la seguridad.

Temperatura Ambiente : 0 a 55°C  
Humedad 5 a 90% RH a 40°C  
Vibración 0 a 200 Hz  
aceleración 0.2 g

### **INSTALACION DEL EQUIPO**

Este equipo debe ser montado en un panel para limitar al operador el acceso a los terminales traseros.

## SÄKERHETSFÖRESKRIFTER

SW2I-6056



För att reducera riskerna av elektriska chocker som kan orsaka personskador, följ alla säkerhetsföreskrifter i denna dokumentation.



Denna symbol varnar användaren för risk för elchock vid tillfällig åtkomst av spänningsförande del.



Anslutning av skyddsjord. Avsedd för anslutning av elsystemets skyddsjordsledare.

- Om utrustningen används på ett sådant sätt, att det inte innefattas av tillverkarens specifikation, kan de inbyggda säkerhetsfunktionerna äventyras.
- Ersätt aldrig någon komponent (eller del) som inte är specificerad som ersättningsbar av tillverkaren.
- All ledningsdragnings måste utföras i enlighet med lokala bestämmelser och skall utföras av behörig personal med erfarenhet av sådant arbete.
- Skyddsjordsanslutningen skall anslutas före alla andra anslutningar (och losskopplas sist).
- En strömbrytare för näströmmen rekommenderas.

### **STRÖMFÖRSÖRJNING**

Spänning	102 a 132 Vac - 204 a 264 Vac
Frekvens	50 – 60 Hz
Effekt eller märkström	20 watts max.

### **OMGIVNINGSVILLKOR**

Använd ej instrumentet i närhet av brännbara vätskor eller gaser. Användandet av instrumentet i sådant miljö är en direkt säkerhetsrisk.

Temperatur	Omgivande : 0 till 55°C
Fuktighet	5 till 90% RH - 40°C
Vibration	0 till 200 Hz acceleration 0.2 g

### **INSTALLATION**

Instrumentet skall monteras i en panel eller i en låda för att undvika att personalen kommer i beröring med bakre inkopplingsplintar.

# Index

## 0

0-10 Volt dc inputs, 37  
0-10 Volt inputs, 212

## 4

4-20 mA auxiliary output wiring, 52  
4-20 mA control output wiring, 39  
4-20 mA input wiring, 35  
4-20 mA inputs, 213

## A

AC line power, 30  
Accutune II, 159  
Alarm hysteresis, 79, 127  
Alarm messages, 147  
Alarm outputs, 45  
Alarm setpoints, 162  
Alarms group definitions, 126  
Atmospheric pressure compensation, 82, 131  
Automatic calibration mode, 223  
Automatic local mode, 149  
Automatic mode  
    Return to, 150, 184  
    Selecting, 149  
Automatic remote mode, 149  
Automatic switchover, 109  
Automatic switchover value, 73, 110  
Auxiliary Output, 79, 80, 84  
Auxiliary output 2 and 3 calibration, 220

## B

Basic recorder components without options, 248  
Battery test failure, 235  
Baud rate, 81  
Bias, 111  
Bias for remote setpoint, 73  
Burnout, 65  
Burnout protection, 97

## C

Calibration procedure, 214  
Calibration set up, 206  
    0-10 Volt inputs, 212  
    4-20 mA inputs, 213  
    Millivolts and Volts inputs (except 0-10 Volts), 211  
    RTD inputs, 210

    Thermocouple inputs using a compensated calibrator method, 208  
    Thermocouple inputs using an ice bath, 207  
    Thermocouple inputs using the ambient temperature method, 209  
CE Conformity (Europe), 1  
CE Conformity special conditions, 7  
CE conformity special conditions (Europe), 27  
Chart high range value, 98  
Chart lamp, 169  
    Replacing, 169  
Chart low range value, 98  
Chart name, 67, 69, 101  
Chart plate assembly parts, 247  
Chart speed selection, 67, 69  
CHN indicator, 148  
Circuit-breaker, 30  
Cleaning, 169  
Communications station address, 81, 130  
Condensed specifications, 8  
Configuration procedure, 62  
Configuration prompts, 57  
Configuration tips, 61  
Control algorithm, 74, 114  
Control output direction, 74, 112  
Controller dropoff value, 74, 112  
Current proportional output calibration, 220, 225  
Current simplex, 116  
Current/relay duplex, 117  
Current/time duplex range, 74  
Customer support, 229  
Cycle time (heat), 121  
Cycle time 2 (cool), 121

## D

Deadband, 74, 112  
Decimal point location, 64, 94  
Deviation, 131  
Deviation bargraph, 144  
Deviation recording action, 82  
Deviation setpoint value, 82, 131  
Device status, 232  
Diagnostic error messages, 146  
Diagnostic tests, 138  
Digital inputs, 45  
Dimensions, 16  
Direct acting control, 112  
Display test, 139  
Displaying totalizer value, 166  
Displays, 3

- Electrical noise, 27  
 Emissivity, 65  
 Engineering units, 94  
 Error message  
   BATT LOW. *See*  
   BATTERY, 235  
   CAL TEST, 234  
   CAL1 ERR, 234  
   CAL2 ERR, 234  
   CONFTEST, 233  
   EE FAIL, 235  
   FACT CRC, 234  
   FAILSAFE, 233  
   INxFail, 235  
   PV LIMIT, 235  
   RAM TEST, 233  
   RV LIMIT, 235  
   SW FAIL, 235  
 Error message prompts, 233  
 Error messages, 146  
 Event message configuration, 83  
 Event pen function, 167  
 Event pen operation, 167
- E**
- Factory calibration, 200  
 Failsafe, 231  
 Failsafe output value, 74  
 Failure symptoms, 229  
 Ferrite filter locations (CE Mark), 29  
 Field wiring, 203  
 Filter, 65, 97  
 Fo reset, 258  
 Fo sterilization calculation, 258  
 Fo sterilization time, 259
- F**
- Gain, 120  
 Gain 2, 121  
 Gain units, 74  
 Grid line contrast, 136, 140
- G**
- Hardware kit contents, 252  
 Header for chart, 67, 101  
 High output limit, 74, 112  
 High range value, 65, 96  
 High setpoint limit, 73  
 Hours per revolution, 100  
 Hysteresis, 74, 113, 127
- H**
- Ice bath, 204  
 Indicators, 3  
 Input 1 actuation type, 64
- Input actuation type, 95  
 Input compensation, 65, 97  
 Input out of range, 236  
 Input terminals, 203  
 Inputs  
   0–5 Vdc, 33  
   Radiamatic, mV, 33  
   RTD, 33  
   Thermocouple, 33  
 Installation  
   Operating limits, 8  
   Preinstallation information, 7  
 Installing chart, 170  
 Internal cabling, 253
- I**
- Jumper positions, 205
- J**
- Key test, 139  
 Knockout locations, 17
- K**
- L**
- Local setpoint, 151  
 Local setpoint, 110  
 Lockout, 86, 87, 134  
 Lockout password, 86, 87  
 Low flow cutoff selection, 65  
 Low output limit, 74, 112  
 Low range value, 65, 97  
 Low setpoint limit, 73
- L**
- Maintenance, 169  
 Manual calibration mode, 223  
 Manual mode, 149  
   Adjusting output, 150, 151, 183, 184  
   Selecting, 150  
 Manual reset, 120  
 Minutes per repeat, 114  
 Monitoring your recorder, 142  
 Motor traverse time, 223  
 Mounting  
   Overall dimensions, 16  
 Mounting methods, 17  
   2-inch pipe, 24  
   Flush in panel, 18, 20  
   Flush in panel, 21  
   NEMA4X door, 22  
   Surface, 25
- M**
- O**
- ON/OFF algorithm, 114  
 Operating limits, 8  
 Operating modes, 149  
 Operating parameters, 145

Operator functions, *148*  
 Operator interface, *3, 142*  
 Output algorithm, *74, 116*  
 Output wiring for alarms 3 and 4, *47*  
 Output wiring for alarms 5 and 6, *48*

## P

Parts lists, *245*  
 Password, *134*  
 PD with manual reset, *115*  
 Pen Set Up group, *66*  
 Pen tip, *169*  
   Cleaning, *169*  
 Physical considerations, *16*  
 PID A, *115*  
 PID B, *115*  
 PID sets, *158*  
 Pipe mounting, *24*  
 Polynomial Equation, *107*  
 Position proportional control output wiring, *41*  
 Position proportional output calibration, *222*  
 Position proportional simplex, *117*  
 Power loss, *172*  
 Power supply mains, *30*  
 Power up controller mode recall, *73, 111*  
 Power up diagnostic tests, *138*  
 Power-up tests, *231*  
 Printing characteristics adjustments, *135, 217*  
 Prompt hierarchy, *57*  
 Proportional band, *120*  
 Proportional band 2, *121*  
 Proportional band units, *113*

## R

Radiamatic, millivolts, and volts inputs (except 0–10 Volts), *211*  
 Ramp/soak program, *123*  
 Rate 2, *121*  
 Rate action, *120*  
 Rate of integration, *70, 105*  
 Ratio, *110*  
 Ratio for remote setpoint, *73*  
 Recorder components associated with options, *250*  
 Recovery from a power loss, *172*  
 RECYCL parameter, *185*  
 Rejection frequency, *79, 82, 84, 131*  
 Relative humidity, *82, 131*  
 Relay control output wiring, *43*  
 Relay duplex, *117*  
 Relay/current duplex, *117*  
 Remote chart activation, *68, 102*  
 Remote setpoint, *110*  
 Remote switching, *164*  
 Repeats per minute, *114*  
 Replacing chart, *170*  
 Reset, *120*  
 Reset 2, *121*  
 Reset units, *74, 114*  
 Resetting totalizer value, *165*

Resistance equivalent, *202*  
 Restoring factory calibration, *200*  
 Reverse acting control, *112*  
 RS485 Modbus communications wiring, *50*  
**RSP**, *152*  
 RTD inputs, *210*

## S

Safety Requirements for Electrical Equipment, *27*  
 Self diagnostics, *229*  
 Setpoint high limit, *112*  
 Setpoint low limit, *112*  
 Setpoint program  
   profiles set-up, *187*  
 Setpoint Program  
   Data entry, *183*  
   event setup, *192*  
   overview, *173*  
   ramp setup, *185*  
   run/monitor functions, *196*  
   segment setup, *189*  
 Setpoint ramp, *122*  
   Configuring, *153*  
   Running, *154*  
 Setpoint ramp final setpoint, *123*  
 Setpoint ramp time, *123*  
 Setpoint selection indication, *152*  
 Setpoint source, *73, 110, 151*  
 Setpoint tracking, *73, 111*  
 Set-up tasks, *5*  
 Shield wiring, *29*  
 Single setpoint ramp, *122, 153*  
 SOKDEV parameter, *185*  
 SPPROG parameter, *185*  
 Start up, *139*  
 Stylus, *136, 140*  
 Suppression filters, *29*  
 Switchover value, *157*

## T

Temperature units, *64, 94*  
 Thermal resistance, *259*  
 Thermocouple inputs using a compensated calibrator method, *208*  
 Thermocouple inputs using an ice bath, *207*  
 Thermocouple inputs using the ambient temperature method, *209*  
 Three position step control output wiring, *41*  
 Time division, *101*  
 Time parameters group definitions, *103*  
 Totalizer, *70*  
 Totalizer group definitions, *104*  
 Totalizer reset, *70, 73*  
 Totalizer scale factor, *70, 73*  
 Totalizer value, *165*  
   Displaying, *166*  
   Resetting, *165*  
 Trace line contrast, *136, 140*  
 Transmitter characterization, *65, 96*

Troubleshooting procedures, 238  
Transmitter power, 35  
Tuning constants, 156  
Tuning group prompt definitions, 119  
Tuning messages, 147  
Tuning parameter sets, 73, 109  
Two local setpoints, 110  
Two sets of tuning constants, 156

## V

Visual failure symptoms, 229, 237  
Voltage equivalent, 202

## W

Wake time days, 103  
Wake time hours, 103  
Wake time minutes, 103  
Wake time months, 103  
Wire bundling, 28  
Wiring  
    0-10 Vdc inputs, 37  
    0-5 Vdc inputs, 33  
    4-20 mA auxiliary output, 52  
    4-20 mA control output, 39  
    4-20 mA inputs. *See*  
    AC line power. *See*  
    Electrical noise precautions, 27  
    mV inputs, 33  
    Position proportional control output, 41  
    Radiamatic inputs, 33  
    Relay control output, 43  
    RS485 Modbus communications, 50  
    RTD inputs, 33  
    Shields, 29  
    Thermocouple inputs, 33  
    Three position step control output, 41  
    Transmitter power. *See*  
    Wire bundling, 28  
    Wiring the recorder, 29  
Wiring for PV inputs, 206  
    0-10 Volt inputs, 212  
    4-20 mA inputs, 213  
    Millivolts and Volts inputs (except 0-10 Volts), 211  
    RTD inputs, 210  
    Thermocouple inputs using a compensated calibrator  
    method, 208  
    Thermocouple inputs using an ice bath, 207  
    Thermocouple inputs using the ambient temperature  
    method, 209





**Honeywell**

AUTHORIZED DISTRIBUTOR

**De Gidts & Feldman BV**  
**The Netherlands**  
**w w w . d g f g . n l**



**De Gidts & Feldman**

INSTRUMENTATION & FILTRATION

---

**Honeywell**

**Industrial Measurement and Control**

Honeywell

1100 Virginia Drive

Ft. Washington, PA 19034

44-45-25-30 Rev. L 0802 Printed in USA

[www.honeywell.com/imc/](http://www.honeywell.com/imc/)