

Rigid instrumentation protection

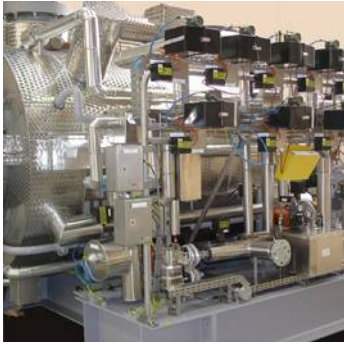

These enclosures are matching mouldings of GRP double skinned thermal insulating material, and are designed to fit around the primary "wetted" parts of differential pressure transmitters and similar instruments in conjunction with either steam or electric heating.

Double skinned constructions offers rugged, impact resistant, low heat loss construction with non-ingress of hydrocarbons, and enclosures are retained with heavy duty stainless steel toggle fasteners with over centre action. Toggle fasteners are fixed by stainless steel nuts, bolts and washers.



Series 66

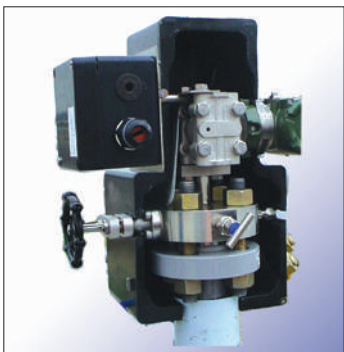
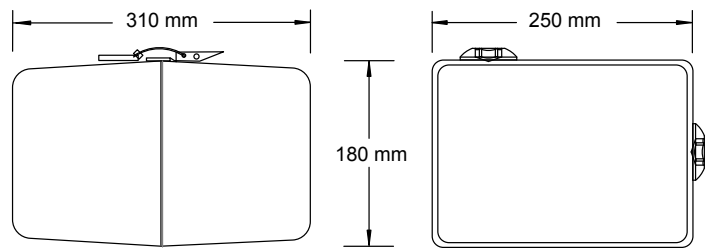

Series 77

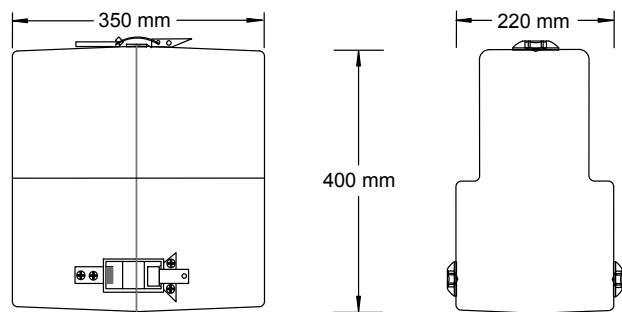

Series 88

