

STT 3000 – Series STT250 Smart Temperature Transmitter

Models STT25D, STT25M, STT25S, STT25H, STT25T

Operator Manual

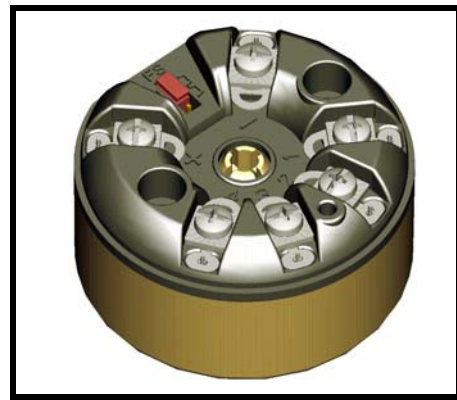

TABLE OF CONTENTS

1. OVERVIEW	1
1.1 INTRODUCTION	1
1.2 CE CONFORMITY (EUROPE) NOTICE	2
2. TECHNICAL SPECIFICATIONS	3
2.1 ENVIRONMENTAL CONDITIONS	3
3. THEORY OF OPERATION	4
3.1 BASIC OPERATION	4
3.2 CONFIGURATION TOOLS	5
3.2.1 <i>Smart Field Communicator (SFC) for STT25M and STT25D Models.....</i>	<i>5</i>
3.2.2 <i>HART Communicator Model 375, 475 or MC Toolkit FDC for STT25H (HART5/HART6) Models.....</i>	<i>6</i>
3.2.3 <i>HART Communicator Model 375, 475 or FDC Toolkit for STT25T (HART5/HART6) Models.....</i>	<i>8</i>
3.2.4 <i>HART Communicator Model 375 and 475 for STT25S Model.....</i>	<i>10</i>
3.2.5 <i>Smartline Configuration Toolkit (SCT).....</i>	<i>12</i>
3.2.6 <i>STT250 Firmware – DD Compatibility matrix.....</i>	<i>13</i>
4. BENCH CHECK INSTALLATION/COMMISSIONING	15
4.1 UNPACKING.....	15
4.2 EQUIPMENT.....	15
4.3 INSTALLATION.....	15
4.4 GROUNDING AND SHIELDING TECHNIQUES	17
4.5 STT250 CONFIGURATION	17
4.5.1 <i>Analog Output Configuration (based on STS103) for STT25M and STT25D Models.....</i>	<i>17</i>
4.5.2 <i>DE Digital Output Configuration.....</i>	<i>20</i>
4.5.3 <i>HART Configuration (Models STT25H and STT25S).....</i>	<i>21</i>
4.5.4 <i>HART Configuration (STT25T HART5/HART6 Models).....</i>	<i>36</i>
4.6 MOUNTING.....	40
4.6.1 <i>DIN Rail Mounting.....</i>	<i>40</i>
4.6.2 <i>Mounting Module in Housing.....</i>	<i>40</i>
4.7 COMMISSIONING	2
4.8 START UP	45
4.9 ADVANCED DIAGNOSTICS	45
4.9.1 <i>Install Date.....</i>	<i>45</i>
4.9.2 <i>Time in service.....</i>	<i>45</i>
4.9.3 <i>Error Log.....</i>	<i>45</i>
4.9.4 <i>Calibration records.....</i>	<i>45</i>
4.9.5 <i>Power up diagnostics.....</i>	<i>45</i>
4.9.6 <i>PV/SV monitoring.....</i>	<i>45</i>
4.9.7 <i>Sensor short detection (only for RTD).....</i>	<i>46</i>
4.9.8 <i>Model number.....</i>	<i>46</i>

4.9.9	Serial number.....	46
4.10	ENHANCED DD	47
4.10.1	Status Indication.....	47
4.10.2	Manufacturer logo and Device Image.....	47
4.10.3	Wiring Diagrams.....	48
4.10.4	Trend Charts.....	49
4.10.5	Gauge charts.....	49
4.10.6	Horizontal bar chart.....	49
4.11	CVD COEFFICIENTS FOR RTD	50
5.	MAINTENANCE/TROUBLESHOOTING	51
5.1	MAINTENANCE	51
5.2	TROUBLESHOOTING.....	51
5.2.1	Troubleshooting with SFC (STT25M and STT25D Models).....	51
5.2.2	Troubleshooting with HART communicator (STT25H, STT25S, and STT25T Models).....	54
5.3	RECOMMENDED PARTS.....	59
5.4	WIRING AND INSTALLATION DRAWINGS NUMBERS	60
6.	INDICATION METERS.....	61
6.1	INTRODUCTION.....	61
6.2	CONNECTION INFORMATION	61
6.3	INSTALLATION/COMMISSIONING	62
6.3.1	DE Transmitter (STT25D Model) Operating in 6 Byte Output Mode.....	62
6.3.2	DE Transmitter (STT25D Model) Operating in 4 Byte Digital Output or in 4-20 mA Analog Mode.....	62
6.3.3	DE Transmitter (STT25D and STT25M Models) Operating in 4-20 mA Analog Output Mode.....	62
6.4	DIAGNOSTIC AND TROUBLESHOOTING.....	63
6.4.1	Analog Meter	63
6.4.2	Smart Meter	63
6.4.3	4-20 mA Analog Mode Calibration of Smart Meter (DE Transmitter STT25D and STT25M Models only).....	65
7.	APPENDIX A.....	66
A.1	OVERVIEW.....	66
A.2	FEATURES AND BENEFITS	66
A.3	ELECTRICAL CHARACTERISTICS	66
A.4	INSTALLATION PROCEDURE	67
A.5	WIRING REFERENCE.....	68
A.6	FM CONTROL DRAWING 46188466-201.....	69
A.7	CSA CONTROL DRAWING 46188466-202	77
8.	CERTIFICATION.....	97
8.1	IECEX CERTIFICATION	97
8.2	SAEX CERTIFIED EQUIPMENT (SOUTH AFRICA)	99

FIGURES AND TABLES

Figure 1: Operating Areas	3
Figure 2: Bench Check Wiring Connections	15
Figure 3: Output Sensor Wiring Connections (STT25M, STT25D, STT25H, and STT25S models)	16
Figure 4: Input Sensors Wiring Connections (STT25T Model)	16
Figure 5: Flow Chart for analog and DE Configuration	19
Figure 6: Specific Flow Chart for DE Configuration	20
Figure 7 HART 5 DD Menu Structure for STT25H and STT25T Configuration.....	28
Figure 8 HART 6 DD Menu Structure for STT25H, STT25S and STT25T Configuration.....	35
Figure 9: DIN Rail Mounting	40
Figure 10: Wall Mounting Dimensions	1
Figure 11: Pipe Mounting Dimensions.....	2
Figure 12: Spring Loading and Sensor Assembly	1
Figure 13: Aluminium Direct Head Mount Housing Dimensions	2
Figure 14: Cast Iron Direct Head Mount Housing Dimensions.....	2
Figure 15: Meters Connections.....	61
Figure 16: Horizontal Style Bargraph.....	63
Figure A17: Typical wiring of transient protector to STT250 transmitter....	68
Table 1 - When « SENSOR FAIL » is set in STT250	59
Table A2 Electrical Characteristics	66
Table A3 Transient Protector Installation.....	67

1. OVERVIEW

1.1 Introduction

The STT250 Series Smart Temperature Transmitter is a microprocessor based unit suitable for accepting a wide variety of thermocouple and resistance temperature detector sensor inputs or direct ohm or milli-volt inputs and providing a 2 wire 4-20 mA “Analog”, digital “DE”, or analog “HART®” proportional output.

The transmitter offers high accuracy and stability together with wide flexibility to suit a wide range of applications. All adjustments and operational settings are implemented through the Smart Field Communicator (DE) or the HART® communicator (HART®). Both field communicators access the transmitter by connecting across the 4-20 mA wiring in parallel with the STT250 anywhere along the wiring up to 1500 meters from the transmitter for both the DE and HART® protocol versions.

Note: 1500 m is the maximum HART® cable length but may be restricted by cable capacitance limits.

- Model STT25M provides a 4-20mA analog output and is configurable with the Honeywell Smart Field Communicator (SFC) or the PC based Smartline Configuration Toolkit (SCT). The terminal assembly is black for visible differentiation.
- Model STT25D provides both the 4-20mA analog output as in Model STT25M or the digital DE protocol for digital integration to the Honeywell control system or other compatible interfaces. The terminal assembly is black for visible differentiation.
- Model STT25H provides the output per the HART® communication protocol. STT25H supports both version HART5 and HART6 protocol. The terminal assembly is blue for visible differentiation.
- Model STT25S provides the output per the HART® communication protocol and TUV SIL 2 safety rating. The terminal assembly is blue for visible differentiation (with SIL certification). Only HART6 protocol for STT25S.
- Model STT25T can be configured to have average/ difference of 2 inputs. The STT25T can be used for redundant switchover (except for RTD/RTD) and used with split range (switches over from one sensor to the other at a user-defined value, so as to use accuracy region of both sensors). The STT25T can also be used as an indication of sensor degradation. STT25T can be used as a single input transmitter for all sensor types (thermocouple, mv, rtd,ohms). STT25T supports both version HART5 and HART6 protocol. It is configurable with the HART® hand held communicator or a PC based HART® maintenance system (such as Honeywell’s FDM and Experion system). STT25T HART6 version carries SIL certification.

The STT250 series is based on a rugged compact package with encapsulated electronics for high reliability and includes facilities for spring loading of the sensor at a 33 mm pitch in accordance with DIN 43729. The unit is available either for DIN rail mounting or supplied in a variety of enclosures for direct sensor, pipe or wall mounting (See Figure 9 through Figure 14).

“HART® is a Registered Trademark of HART Communication Foundation.”

“The STT3000 Smart Temperature Transmitters are manufactured under at least one of the following patent numbers: 4.734.873, 4.592.002, 4.587.466, 4.553.104, 4.494.183”

Model table

Model Name →	STT25S	STT25H	STT25T	STT25D	STT25M
Protocol	HART6	HART5 & HART6	HART5 & HART6	4-20 mA analog OR DE	4-20 mA analog
Configuration Tool	MCToolkit, Emerson's 375/475, Honeywell's FDM, CodeWright's DTM	MCToolkit, Emerson's 375/475, Honeywell's FDM, CodeWright's DTM	MCToolkit, Emerson's 375/475, Honeywell's FDM, CodeWright's DTM	MCToolkit, SFC & SCT, Honeywell's FDM,	MCToolkit, SFC & SCT, Honeywell's FDM,
Terminal Assembly colour	Blue	Blue	Blue	Black	Black
Whether SIL certified?	Yes	No	Yes (HART6 version only)	No	No

1.2 CE Conformity (Europe) Notice

<p>About conformity and special conditions</p> 	<p>This product is in conformity with the protection requirements of 2004/108/EC, the EMC Directive. Conformity of this product with any other “CE Mark” Directive(s) not referenced in this manual shall not be assumed.</p> <p>Deviation from the installation conditions specified in this manual, and the following special conditions, may invalidate this product's conformity with the EMC Directive.</p> <ul style="list-style-type: none"> • You must use shielded, twisted-pair cable such as Belden 9318 for all signal/power wiring. • You must connect the shield to ground at the power supply side of the wiring only and leave it insulated at the transmitter side.
<p>ATTENTION</p>	<p style="text-align: center;">ATTENTION</p> <p>The emission limits of IEC 61000-6-4, Electromagnetic Compatibility – Generic Emission Standard for Industrial Environments, are designed to provide reasonable protection against harmful interference when this equipment is operated in an industrial environment. Operation of this equipment in a residential area may cause harmful interference. This equipment generates, uses and can radiate radio frequency energy and may cause interference to radio and television reception when the equipment is used closer than 30 meters (98 feet) to the antenna(e). In special cases, when highly susceptible apparatus is used in close proximity, the user may have to employ additional mitigating measures to further reduce the electromagnetic emissions of this equipment.</p>

2. TECHNICAL SPECIFICATIONS

2.1 Environmental Conditions

<i>Parameter</i>	<i>Reference Condition</i>	<i>Rated Condition</i>	<i>Operative Limits</i>	<i>Transportation And Storage</i>
Ambient temperature °C	23 °C ± 2	-40 to +85	-40 to +85	-50 to +100
Humidity				
Rack mounted % RH	10 to 55	5 to 95	5 to 100	5 to 100
In field housing % RH	10 to 55	5 to 100	5 to 100	5 to 100
Supply voltage	Voltage range 10.8 to 35 Vdc at the transmitter terminals			
Output current - Standard	Over linear range 3.8 to 20.8 mA. Failsafe limits < 3.6 and >21.1 mA			
Output current – NAMUR NE43	Over linear range 3.8 to 20.5mA. Failsafe limits < 3.6 and >21.1 mA			
Load resistance	0 to 1110Ω			
Vibration	Maximum of 4g over 15 to 200Hz (restricted to 3g with indication meter).			
Shock	Maximum of 40g.			

CE MARK compliance:

In compliance with EMC directive 89/336/ECC:

- without shielded wires 10 V/m, ± 0.2% of Max span
- with shielded wires and mounted in metallic housing: 10 V/m, ± 0.1% of max span.

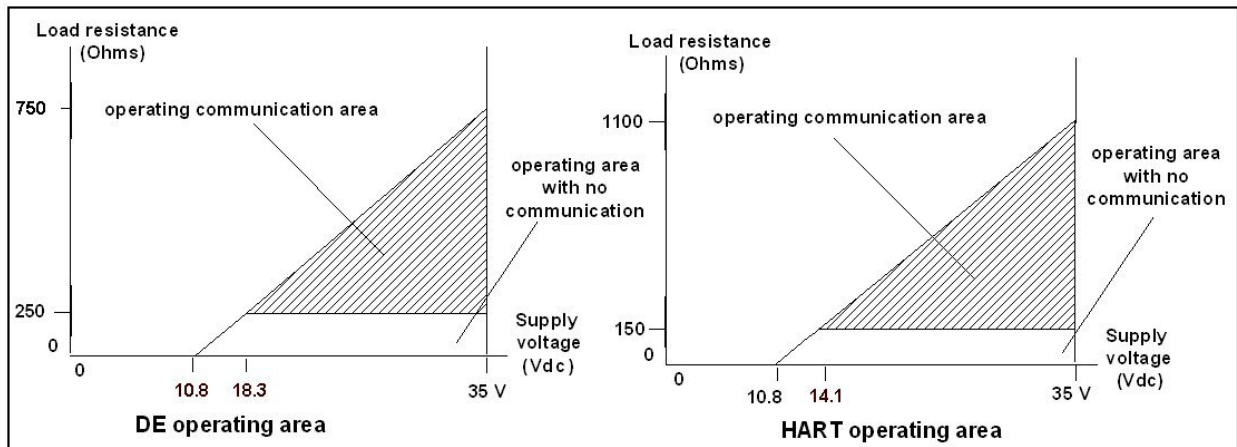

Figure 1: Operating Areas

3. THEORY OF OPERATION

3.1 Basic Operation

As shown in Figure 2, the transmitter is powered via the 2 wire, 4-20 mA signal connected to the + and - terminals on the output side of the module. Inputs are sampled and the input sampling/output update rate is once per second, digitized by the A/D converter. Data is then transferred across the galvanic isolation interface (both power supply and signal interface of the A/D converter are galvanically isolated), compensated for cold junction or resistance lead length. The process value is post read validated for sensor wiring and signal integrity against reference values. Digital data is then linearized and ranged to the lower and upper range values held in non volatile memory and converted back to an analog signal. Any configuration changes are held in non volatile memory so that they are secured against power failure. If a custom configuration was not specified, the data programmed into the non volatile memory of the unit at the manufacturing location is the default shipping data shown below.

	STT25M & STT25D	STT25H	STT25T	STT25S
Sensor type	mV	mV	TC/TC, mV	mV
Sensor fault detection	ON			
Tag I. D.	Short Tag			
Latching	Disabled			
Line filter	50 Hz (Europe) - 60 Hz (Americas)			
Output type	Non-linear			
Write protect	Disabled ⁽¹⁾			
Password	0000			
Damping	0 second			
LRV (Lower Range Value)	0 mV	-20 mV		
URV (Upper Range Value)	45 mV	150mV		
Input Sampling/ Output update rate	Once per second			
Output mode	Analog			
Digital DE conf.	6 byte/Single rng.-S V	N/A		
Long Tag	NA	Long Tag (for HART6 model only)		

The data can be configured in the field by connecting a Communicator across the 4-20 mA input or by connecting to a PC via a HART or DE modem. The fail-safe link between the U and D terminals determines where the output will drive when the STT250 detects an open sensor input or critical failure. The unit will drive upscale above 21.1 mA for open sensor input or critical error when the fail-safe link is in the U position and downscale to below 3.6 mA in the D position.

The output of the STT250 can be configured for either analog or digital modes for DE protocols (with the exception of STT25M, which is analog-only). This improves performance by avoiding conversion to/from an analog signal and offers full database integration of field transmitters with the central control system.

(1) To protect the integrity, write protect is software configurable and accessible through a password. The fall-back password is an algorithm based on the unit serial number. If the password is lost, contact your regional Technical Assistance Center (TAC) with the unit serial number.

3.2 Configuration Tools

3.2.1 Smart Field Communicator (SFC) for STT25M and STT25D Models

As previously indicated, the SFC communicates by connecting across the 4-20 mA wiring. DE Communication is by 16 mA pulses which disturb the 4-20 mA output signal. When in analog mode, ensure that receiving instruments are not on automatic control. The SFC does not feed 16 mA pulses into the loop but instead merely uses the power on the 4-20 mA wires and switches it through a field effect transistor output switch. The SFC always acts as a master and the transmitter as a slave. When the transmitter is operating in the digital DE mode, there is no wake-up pulse required and the SFC communication does not disturb the PV signal. Consequently, there is no need to put the loop on manual control when operating in the DE mode.

Supported Commands:

- * Read/write ID (e.g. TID 250)
- * Select a sensor type (e.g. Pt100)
- * Select linear/non linear reading (i.e. Linear for °C etc., Non linear for Ω and V)
- * Enable/disable sensor break detection
- * Set damping time (e.g. 0 second)
- * Set LRV and URV
- * Read URL (upper range limit), LRL (lower range limit) and span
- * Read process value and cold junction value in engineering units
- * Read output in % of span
- * Read STT250's software version
- * Read fail-safe direction configured by link
- * Set/reset user calibration to specific sensor
- * Set 0 and 100% output calibration
- * Force output current
- * Read/write scratch pad
- * Select broadcast type 4 or 6 bytes (Digital DE only). 6 bytes broadcasts PV and transmitter database while 4 bytes broadcasts PV only
- * Enable/disable write protect
- * Select 50 Hz/60 Hz power line filter
- * Enable/disable latching. Latching means the alarm needs acknowledgment. Press "STATUS" key to acknowledge the alarm.
If latching is disabled, the STT250 will leave the alarm mode as soon as the alarm cause disappears.
- * Change to NAMUR output levels⁽¹⁾

⁽¹⁾ Not available on STT25D

3.2.2 HART Communicator Model 375, 475 or MC Toolkit FDC for STT25H (HART5/HART6) Models

Connect the HART Communicator by attaching the leads in parallel with the input (24V) terminals of the device. HART Communication consists of a high frequency carrier superimposed onto the 4-20 mA signal. The HART transmitter transmits by modulating the 4-20 mA DC loop current with a 1 mA p-p AC current signal. This modulated signal permits communications without disturbing the output signal. Thus, it is unnecessary to put the loop on manual control with Model STT250 Models.

Model STT25H

Supported Commands:

- * Read/write ID
- * Select sensor type
- * Select PV/SV units
- * Select damping time
- * Set LRV and URV
- * Read URL and LRL
- * Read analog output
- * Read % Output
- * Read Process Value (PV)
- * Read Cold Junction (CJ) Value
- * Read fail-safe direction
- * Set/reset user calibration
- * Set 0% and 100% output calibration
- * Force output current
- * Enable/disable latching
- * Read device status
- * Set/clear write protect
- * Read/write message, descriptor, date
- * Lock/Unlock device (HART6 Models)
- * Read/Write Long tag (HART6 Models)
- * Read/Write polling address
- * Read/Write loop current mode (HART6 Models)

Advanced Diagnostics

- * Read Install Date
- * Write Install Date
- * Read Calibration Date and Time
- * Write Correct LRV Date and Time
- * Write Correct URV Date and Time
- * Read Time in service value
- * Read first set of Error log data
- * Read second set of Error log data
- * Read Error Log option status
- * Write Error Log option status
- * Reset Error Log
- * Read PV tracking data
- * Read SV tracking data

Advanced Diagnostics (continued)

- * Write high and low alarm limits for PV and SV
- * Reset tracking data
- * Read power up count
- * Reset power up count value
- * Read device model number

RTD Adapter Supported Commands

- * Write Sensor adapter values – Enable/Disable and positive coefficients (applicable when sensor is RTD)
- * Read Sensor adapter values – Enable/Disable and positive coefficients (applicable when sensor is RTD)
- * Write Sensor adapter values – Negative coefficients (applicable when sensor is RTD)
- * Read Sensor adapter values – Negative coefficients (applicable when sensor is RTD)

3.2.3 HART Communicator Model 375, 475 or FDC Toolkit for STT25T (HART5/HART6) Models

The HART Communicator communicates by connecting across the 4-20 mA wiring. Communication is by a high frequency carrier superimposed onto the 4-20 mA signal. The HART transmitter transmits by modulating the 4-20 mA DC loop current with a 1 mA p-p AC current signal. This modulated signal does not disturb the output signal (PV) since the average value of the communication signal is zero. Therefore, it is unnecessary to put the loop on manual control with the STT25T model.

Model STT25T (HART6 model with SIL certification)

Supported Commands:

- * Read/write ID
- * Select Dual Mode TC/TC, RTD/RTD
- * Select sensor type
- * Select PV/SV units
- * Select damping time
- * Set LRV and URV
- * Read URL and LRL
- * Read analog output
- * Read Sensor1 and Sensor2
- * Read % Output
- * Read Process Value (PV)
- * Read Cold Junction (CJ) Value
- * Read fail-safe direction
- * Set 0% and 100% output calibration
- * Force output current
- * Enable/disable latching
- * XS Delta detection ON/OFF
- * Set Delta Alarm
- * Read Delta
- * Match PVs
- * Read device status
- * Set/clear write protect
- * Select Loop Control Mode – Average, Difference, Sensor1, Sensor2, Redundant and Split-Range
- * Lock/Unlock device (HART6 Models)
- * Read/Write Long tag (HART6 Models)
- * Read/write message, descriptor, date
- * Read/Write polling address
- * Read/Write loop current mode (HART6 Models)

RTD Adapter Supported Commands

- * Write Sensor1 adapter values – Enable/Disable and positive coefficients (applicable when sensor1 is RTD)
- * Read Sensor1 adapter values – Enable/Disable and positive coefficients (applicable when sensor1 is RTD)
- * Write Sensor1 adapter values – Negative coefficients (applicable when sensor1 is RTD)
- * Read Sensor1 adapter values – Negative coefficients (applicable when sensor1 is RTD)
- * Write Sensor2 adapter values – Enable/Disable and positive coefficients (applicable when sensor2 is RTD)
- * Read Sensor2 adapter values – Enable/Disable and positive coefficients (applicable when sensor2 is RTD)
- * Write Sensor2 adapter values – Negative coefficients (applicable when sensor2 is RTD)
- * Read Sensor2 adapter values – Negative coefficients (applicable when sensor2 is RTD)

Advanced Diagnostics

- * Read Install Date
- * Write Install Date
- * Read Calibration Date and Time
- * Write Correct LRV Date and Time
- * Write Correct URV Date and Time
- * Read Time in service value
- * Read first set of Error log data
- * Read second set of Error log data
- * Read Error Log option status
- * Write Error Log option status
- * Reset Error Log
- * Read PV tracking data
- * Read SV tracking data
- * Write high and low alarm limits for PV and SV
- * Reset tracking data
- * Read power up count
- * Reset power up count value
- * Read device model number
- * Read Sensor1 and Sensor2 limits
- * Read middle range value (MRV)
- * Write middle range value (MRV)
- * Read Loop Control option value
- * Write Loop Control option value
- * Read hysteresis
- * Write hysteresis value
- * Read damping value for bump less transfer (applicable to Split Range option)
- * Write damping value for bump less transfer (applicable to Split Range option)

3.2.4 HART Communicator Model 375 and 475 for STT25S Model

The HART Communicator communicates by connecting across the 4-20 mA wiring. Communication is by a high frequency carrier superimposed onto the 4-20 mA signal. The HART transmitter transmits by modulating the 4-20 mA DC loop current with a 1 mA p-p AC current signal. This modulated signal does not disturb the output signal (PV) since the average value of the communication signal is zero. Thus, it is unnecessary to put the loop on manual control with Model STT25S. (with SIL certification)

Supported Commands:

- * Read/write ID
- * Select sensor type
- * Select PV/SV units
- * Select damping time
- * Set LRV and URV
- * Read URL and LRL
- * Read analog output
- * Read % Output
- * Read Process Value (PV)
- * Read Cold Junction (CJ) Value
- * Read fail-safe direction
- * Set/reset user calibration
- * Set 0% and 100% output calibration
- * Force output current
- * Enable/disable latching
- * Read device status
- * Set/clear write protect
- * Read/write long tag ID
- * Read/write loop current mode
- * Lock/unlock device
- * Read/write message, descriptor, date
- * Read/Write polling address

Advanced Diagnostics

- * Read Install Date
- * Write Install Date
- * Read Calibration Date and Time
- * Write Correct LRV Date and Time
- * Write Correct URV Date and Time
- * Read Time in service value
- * Read first set of Error log data
- * Read second set of Error log data
- * Read Error Log option status
- * Write Error Log option status
- * Reset Error Log
- * Read PV tracking data
- * Read SV tracking data
- * Write high and low alarm limits for PV and SV
- * Reset tracking data
- * Read power up count
- * Reset power up count value
- * Read device model number

RTD Adapter Supported Commands

- * Write Sensor adapter values – Enable/Disable and positive coefficients (applicable when sensor is RTD)
- * Read Sensor adapter values – Enable/Disable and positive coefficients (applicable when sensor is RTD)
- * Write Sensor adapter values – Negative coefficients (applicable when sensor is RTD)
- * Read Sensor adapter values – Negative coefficients (applicable when sensor is RTD)

3.2.5 Smartline Configuration Toolkit (SCT)

The SCT supports several Smartline products which use the DE protocol, including the STT350, STT25M and STT25D. Since the STT25M and STT25D configuration/data are a subset of the STT350, most functions are supported by the current version of the SCT software. The only confusion which may occur is if you try to configure the STT25_ for functions which are available only with the STT350 transmitter, as shown below.

- Sensor types C, D, Ni/NiMo, Radimatic, Pt500, Ni500, Cu10 and Cu25 are only available with STT350.
- External cold junction compensation is only available with STT350.
- SCT does not support HART protocol and should not be used with Model STT25H, STT25S, and STT25T.
- The STT25M cannot be changed from analog to digital DE mode.

To access to the new functionalities of the STT25M and STT25D, you need a SCT3000 Version 5.11.302 or greater.

3.2.6 STT250 Firmware – DD Compatibility matrix

This compatibility matrix includes a listing of the DD files that should be used with a revision of the transmitter firmware.

Device Name	MC Toolkit/FDC HCF DD Files	FDM HCF DD Files	DD files for Emerson 375/ 475
STT25S	020x.fm8	020x.fm6 020x.fm8	1709020x.hdd
STT25H (HART5)	030x.fm8	030x.fm6 030x.fm8	1704030x.hdd
STT25H (HART6)	010x.fm8	010x.fm6 010x.fm8	170B010x.hdd
STT25T (HART5)	0202x.fm8	020y.fm6 020y.fm8	1702020y.hdd
STT25T (HART6)	0102x.fm8	010y.fm6 010y.fm8	170C010y.hdd

x=1 for the initial release and will increment for subsequent updates
y=2 for the initial release and will increment for subsequent updates

Location of the DD files

The HCF DD files and Emerson DD files are located at:

<http://hpsweb.honeywell.com/Cultures/en-US/Products/Instrumentation/SoftwareTools/MCToolkit/SoftwareDownloads/documents.htm>

DD Installation Instructions

MC Toolkit FDC625: Copy the files to the following Library folder structure under FDC625 installation directory on the Pocket PC.

For example ... \ Library\000017\0004 is for STT25H

... \ Library\000017\0009 is for STT25S

Refer to the above firmware table for sub folders for the other device types.

- **For Rosemount 375 (with system software versions prior to 3.2) copy the files to the 375 Easy Upgrade Utility installation folder:**
C:\Program Files\375 Easy Upgrade Utility\PC Database\DD\HART
- **For both the 375 (with system software versions 3.2 and greater) and the 475 copy the files to the Field Communicator Upgrade Utility installation folder:**
C:\Program Files\Field Communicator Easy Upgrade Utility 3.3\PC Database\DD\HART\en\
- Update the DD files on the SD Card following the Easy Upgrade instructions

4. BENCH CHECK INSTALLATION/COMMISSIONING

4.1 Unpacking

Unpack the unit and verify the contents are as ordered.

4.2 Equipment

If a bench check is intended, the equipment needed is:

- ✓ an input sensor(s) suitable for the required application or an equivalent calibrator which can simulate milli-volts, resistance temperature detector, thermocouple or resistance (ohms) inputs,
- ✓ a nominal 24 Vdc power supply with less than 100 mV peak ripple and able to supply at least 40 mA,
- ✓ a Smart Field Communicator (SFC) with STT25M or STT25D or HART Communicator (model 375 or 475) with STT25H, STT25S, or STT25T,
- ✓ connection wiring and 250 ohms resistor,
- ✓ a Digital Voltmeter (DVM) with range covering 0-5 Vdc. If a high speed sampling DVM is used, a 1 Hz (160 msec.) averaging filter is recommended.

NOTE: If you are going to check calibration using a thermocouple input, ensure that the cold junction temperature is stabilized. After connecting and powering up all equipment, including the transmitter, protect the transmitter from air drafts and allow at least 1 hour before taking readings.

4.3 Installation

Connect the equipment as in Figure 2 and Figure 3 and. For more detailed wiring drawings, refer to drawings listed in Section 5.4

ATTENTION: Do not connect power supply to sensor wiring terminals.

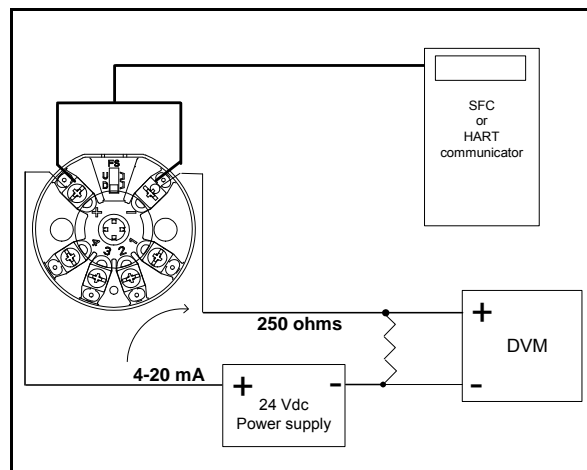

Figure 2: Bench Check Wiring Connections

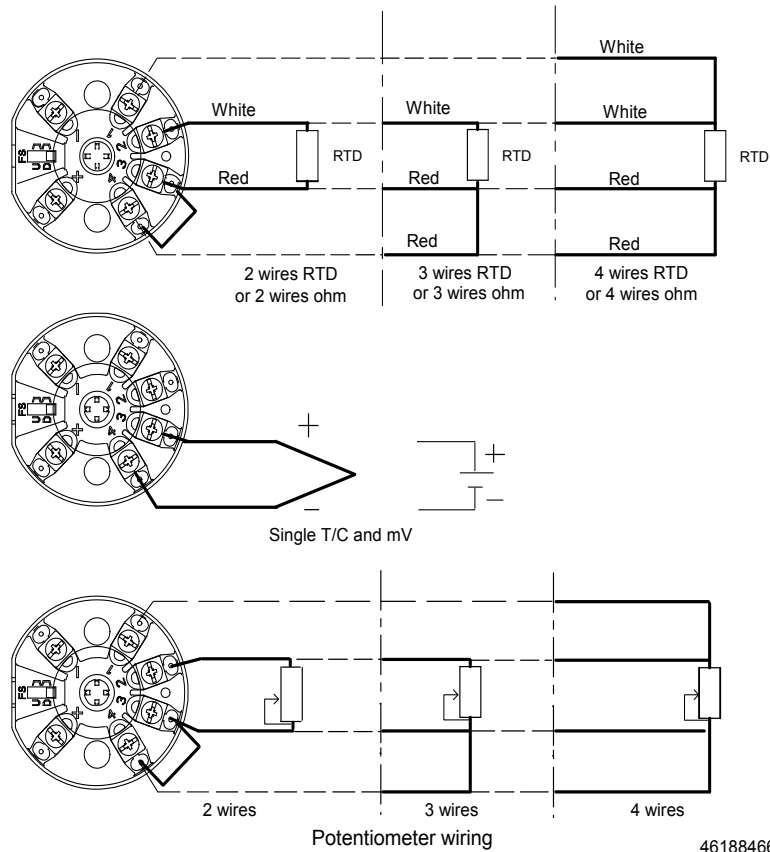

Figure 3: Output Sensor Wiring Connections (STT25M, STT25D, STT25H, and STT25S models)

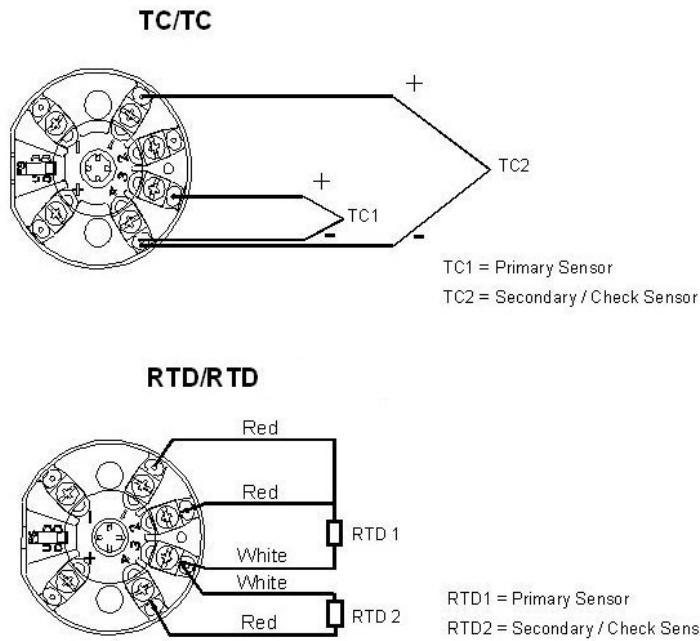

Figure 4: Input Sensors Wiring Connections (STT25T Model)

4.4 Grounding and Shielding Techniques

The current output signal will operate in either a floating or grounded system. If the signal appears noisy or erratic, it is recommended to ground the loop at the negative terminal of the power supply.

Shielding should only be connected to ground at one point to avoid ground loops.

4.5 STT250 Configuration

NOTE: If the transmitter is Model STT25D and configured for digital DE output, the DVM will not display the output during the bench check. The output can be changed to 4-20 mA analog for calibration checks. Remember to change the mode back to digital DE at the completion of the check.

4.5.1 Analog Output Configuration (based on STS103) for STT25M and STT25D Models

1. Turn on the power supply and the SFC. On power up, the SFC will display "**Self Check**" for a few seconds, verify proper operation and display "**put loop in manual**".
2. Press ID button. The transmitter will respond with a display of its name, typically "**STT TagNo XXXXXXXX**". "**STT**" cannot be changed since it identifies the type of transmitter. The current name **XXXXXXXX** has a cursor under the first letter showing that it can be changed to an 8 character alpha-numeric tag number by using number and letter keys.

NOTE: Even though the transmitter is working properly, the SFC may display "CRITICAL STATUS" and an error message when you press "STATUS". The error messages are "INPUT OPEN" "UNCERTAIN READING" "I/P OUT OF SPEC".

The "**CRITICAL STATUS**" message is caused by one of the following:

- ⇒ You have not connected a sensor to the input.
- ⇒ There is an open circuit in the sensor, connecting wiring or terminal connections.
- ⇒ You have connected a T/C or other milli-volt source to the T/C terminals and the transmitter is configured for RTD input (or vice versa).

3. Press "**Status**" to verify "**Status Check = OK**" is displayed.
4. Press "**Conf**" to access the transmitter database and configure it as required. As mentioned earlier, the default shipping mode of engineering units is 0-45 mV input, mV range.

You can now customize the unit to your specific application. The flow chart in Figure 5 gives a simplified overview of selections and key strokes.

See SFC Operating Card 34-ST-11-16 for more details on Latching, NAMUR and Write Protection functionalities.

In summary:

- Press "**Next**" (or ▲) and "**Prev**" (or ▼) to scroll through the different categories.
- Press "**Menu Item**" to access the possible selections of any category: the → key steps on to the next selection while the ← key steps back to the previous selection.

Note that with the "**Menu Item**" key you can only move to the right.

5. When a desired configuration item appears on the SFC display, this item may be configured in the SFC "Hold" memory by pressing "Enter".
When you have completed configuring all items accessible via the "STT Conf" Key, or you try to exit via the "CLR" Key, the SFC will ask "Download Change?". Press "Yes" (Enter) and the changes will be down-loaded from the SFC to the transmitter, or press "No" (CLR) and the SFC hold memory will be erased.
6. Having now configured the input type etc., press "LRV" and key in the required temperature for 4 mA output (e.g. 100°C [212°F]).
7. Press "Enter" to load this into the transmitter and repeat with "URV" for the 20 mA output (e.g. 500°C [932°F]).

Note that if the input type is changed or the output type is changed from linear to non-linear (or vice versa), the LRV and URV values will default to factory set values and the unit selection (°C/°F) will default to °C.

Your STT250 is now configured for your applications.

You can check out the performance by varying the input and observing the output response on the DVM.

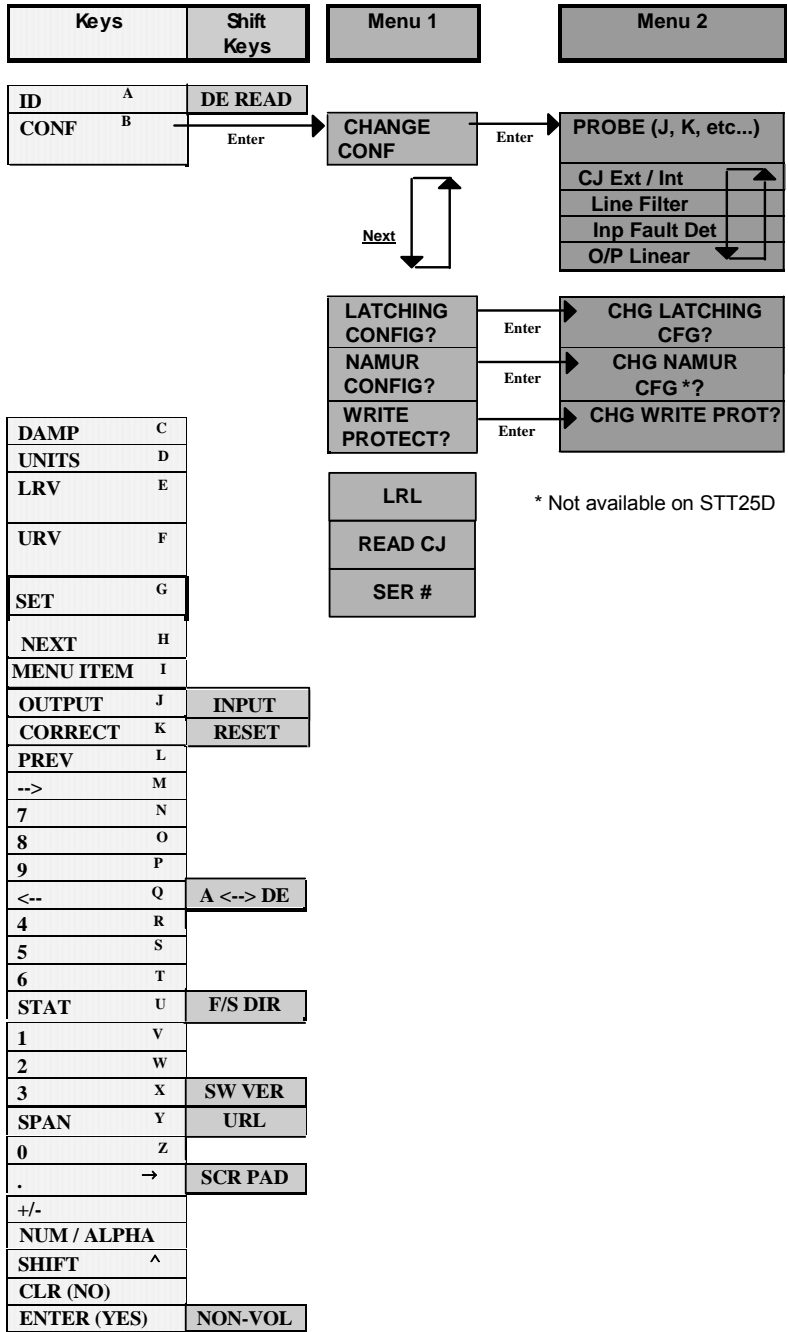

Figure 5: Flow Chart for analog and DE Configuration

4.5.2 DE Digital Output Configuration

The STT25D transmitter can operate in either an analog or a digital DE communications mode. You can use the Smart Field Communicator (SFC) to set transmitter operation mode as analog or digital DE communications. Note that STT25D transmitters are factory set for analog communications operation.

This addendum outlines additional steps for the Configuration Flow Chart in Figure 6 of this Operator Manual to configure parameters for DE communications mode and change transmitter operation from analog to digital DE communications. The DE configuration parameters are:

- Type of transmitter operation,
- Message format,
- Failsafe mode for the digital control system.

Use the following flow chart to supplement in Figure 6 to configure the DE mode parameters and to set your STT25D for DE communications operation.

ADDITIONAL NOTE:

1. Not all failsafe mode selections apply for given type of transmitter operation.
2. SET LRV and SET URV commands are available on STT25D.
3. CONFIG NAMUR command is not available on STT25D.

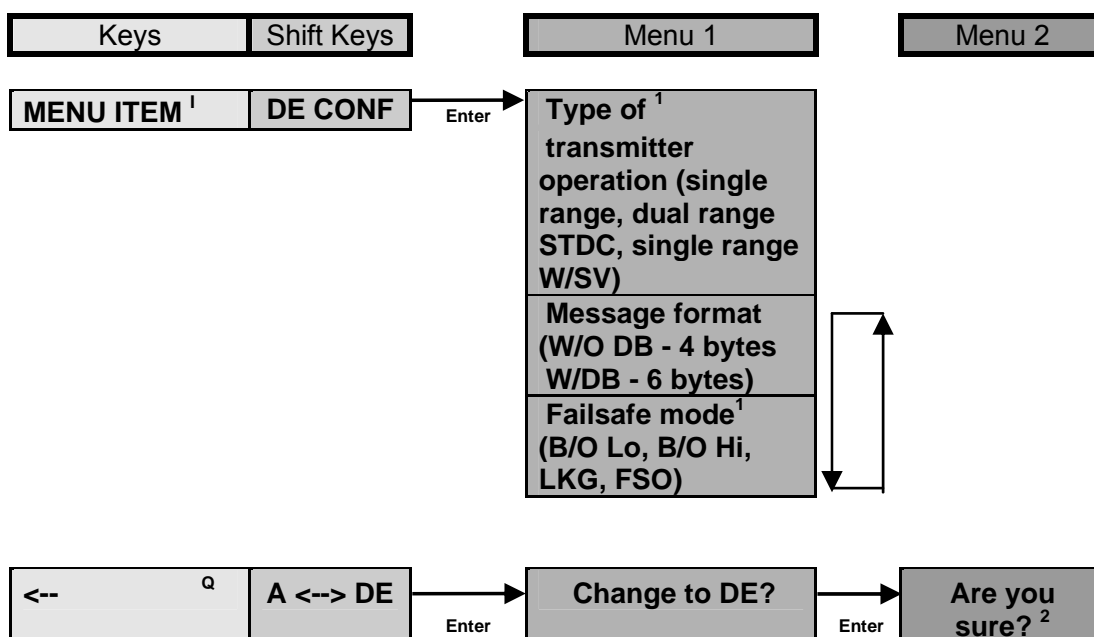

Figure 6: Specific Flow Chart for DE Configuration

1: These parameters are only required for older applications with ST/DC interface cards. They are not used in STI, STIM or STI-MV interface card installations except for selection of with/ without Secondary Variable (SV).

2: You cannot change to DE with a STT25M. If you attempt to do so, an "INVALID REQUEST" message will appear.

Operating card (34-ST-11-16) included with the STS103 covers the smart transmitter functions included in the STT250 (e.g. damping, calibration, output mode etc.). Since the SFC is a universal configuration tool for a wide range of Honeywell transmitters, some proposed menu items are not possible with the STT250, as listed in Section 3.2. In this case, the download will result in an "invalid request" response.

Additional configuration notes:

1. This series mode filter should match the local AC supply frequency. It is set to 60 Hz for United States and to 50 Hz for other countries.
2. Sensor fault detection **"ON"** will drive the output upscale or downscale as selected in the event of an open input condition or in response to most electronic malfunctions. Sensor fault detection **"OFF"** will give an indeterminate output with an open input condition.
3. **"O/P linear"** will always read in degrees (C, F, R or K, as selected) for T/C and RTD inputs. **"O/P non linear"** will read in milli-volts for T/C inputs and in ohms for RTD inputs.

4.5.3 HART Configuration (Models STT25H and STT25S)

1. Turn on the power supply and the HART Communicator.
2. On power up, the communicator will display **"375 Field Communicator"** or **"475 Field Communicator"**. Then select **"HART Application"** and **->** to search for devices. When devices are found they will display as **"STT250: xxxxxxxx"** (xxxxxxx represents the tag) and **"On-line"**.
The process value, output current, LRV and URV are displayed a few seconds later.

NOTE: Even though the transmitter is working properly, the HART Communicator may display "Input Open".

- Press **"NEXT"**. **"Ignore next 50 occurrences of status"** is displayed.
- Confirm with **"YES"** to correct the problem.

The cause is probably one of the following:

- ⇒ You have not connected a sensor to the input.
- ⇒ There is an open circuit in the sensor, connecting wiring or terminal connections.
- ⇒ You have connected a T/C or other milli-volt source to the T/C terminals and the transmitter is configured for RTD input (or vice versa).

3. Press **→** to select **"Device setup"** menu.
4. Select an appropriate menu to access transmitter parameters and settings.

As mentioned earlier, the default shipping mode for units is -20 to 150 mV input, -20 to 150 mV range.

You can now customize the unit to your specific application. The flow chart in Figure 7 gives a simplified overview of selections and key strokes.

- In summary:
- pressing **→** selects a menu,
 - pressing **↑** or **↓** accesses the selections of any category,
 - pressing **←** steps back to the previous menu.

You can check out the performance by varying the input and observing the output response on the DVM.

Additional note :

This line filter should match the local AC supply frequency.

HART 5 DD Menu Structure for STT25H and STT25T Configuration

Device Setup	Process Variables	PV			
		%range			
		AO			
		Sensor1 (25T Only)			
		Sensor2 (25T Only)			
		CJ Temperature			
		Delta (25T Only)			
		LRV			
		MRV (25T Only)			
		URV			
		Loop Controlled by (25T only)			
		Loop Control Mode (25T only)			
		Bar chart for AO			
			PV AO %ge		
		Gauge charts	PV Gauge Chart	↳	PV Meter
			Sensor1 Gauge Chart (25T Only)	↳	Sensor 1 Meter (25T Only)
			Sensor2 Gauge Chart (25T Only)	↳	Sensor 2 Meter (25T Only)
			mA Gauge Chart	↳	mA Meter
		Trends	PV Trend	↳	Trend of PV
			CJ Trend	↳	Trend of CJ
			Sensor 1 Trend (25T Only)	↳	Trend of S1
			Sensor 2 Trend (25T Only)	↳	Trend of S2
			AO Trend	↳	Trend of AO

Device setup (continued)	Diagnostics	Device status	Critical 1		
			Critical 2 (25T only)		
			Non-Critical		
			Info		
			Device Status Image		
		Error Log	Error Log Flag		
			Show Error Log		
			Reset Error Log		
		Power Up Count	Power Up Count		
			Reset Power Up Count		
		Time In Service			
		Variables Monitoring	PV tracking	PV High-Low values	
				↳ PV Low Value	
				↳ PV High Value	
				PV High-Low Alm & Counter	
↳ PV Low Alarm Limit					
↳ PV Low Alarm Counter					
↳ PV High Alarm Limit					
↳ PV High Alarm Counter					
↳ Change PV Alarm Limits					
Reset PV Tracking Values					

Device setup (continued)	Diagnostics (continued)	Variables Monitoring	CJ Tracking	CJ High-Low values	
					↳ CJ Low Value
					↳ CJ High Value
				CJ High-Low Alm & Counter	
					↳ CJ Low Alarm Limit
					↳ CJ Low Alarm Counter
					↳ CJ High Alarm Limit
					↳ CJ High Alarm Counter
					↳ Change CJ Alarm Limits
					Reset CJ Tracking Values
Services	Master Reset				
	Loop Test				
	Write Protection	Write Protect			
		Write Protection On/Off			
		Change Password			
Calibration	Apply Values				
	Enter Values	LRV			
		URV			
		MRV (25T only)			
		LRL			
		URL			
	Correct Input LRV (Not 25T)				
History of LRV corrects (Not 25T)	LRV Correct : Recent				
	LRV Correct : Previous				

Device Setup (continued)	Calibration (continued)	Correct Input URV (Not 25T)	
		History of URV corrects (Not 25T)	URV Correct : Recent
			URV Correct : Previous
		Reset Corrects (Not for 25T)	
		D/A Trim	
	Sensor Limit Values (25T only)		
	Device Configuration	Install Date	
		Dev id	
		Model Number	
		Tag	
		Descriptor	
		Date	
		Message	
		Namur	
		Damp	
		Hysteresis band (25T only) ¹	
		Damp-Bumpless Transfer (25T only) ⁵	
		Poll Addr	
		Line Filter	
		LRV	
		MRV (25T only) ²	
URV			
Honeywell logo			
Device image			
Sensor Configuration	Sensor Selection (Not for 25T)		
	Sensor Type (Not for 25T)		
	Mode Selection (25T only)		
	Mode (25T only)		
	Sensor 1 Type Code (25T only)		
	Sensor 2 Type Code (25T only)		

Device Setup (continued)	Sensor Configuration (continued)	Select PV Unit (not 25T)				
		Select sensor unit (25T only)				
		Select CJ Unit				
		Wire Connection (Not for 25T) ³				
		Loop Control Mode (25T only)				
		Compensation ⁴				
		Delta (25T only)				
		Delta Alarm (25T only)				
		Match PV (25T only)				
		Damp-Bumpless Transfer (25T only) ⁵				
		Wiring diagrams				
				Sensor1 Adapter		
					↳	RTD adapter 1 Selection
				↳	Sensor1 +ve Coeffs	
				↳	B-Postv rng (1)	
				↳	C-Postv rng (1)	
				↳	D-Postv rng (1)	
				↳	E-Postv rng (1)	
				↳	F-Postv rng (1)	
				↳	G-Postv rng (1)	
				Sensor1 -ve Coeffs		
			↳	B-Negtv rng (1)		
			↳	C-Negtv rng (1)		
			↳	D-Negtv rng (1)		
			↳	E-Negtv rng (1)		
			↳	F-Negtv rng (1)		
			↳	G-Negtv rng (1)		

Device Setup (continued)	Sensor Configuration (continued)	RTD Adapter (for S and H, it is only for 1 sensor) ⁶	Sensor2 Adapter	
				↳ RTD adapter 2 Selection
				↳ Sensor2 +ve Coeffs
				↳ B-Postv rng (2)
				↳ C-Postv rng (2)
				↳ D-Postv rng (2)
				↳ E-Postv rng (2)
				↳ F-Postv rng (2)
				↳ G-Postv rng (2)
				Sensor2 -ve Coeffs
				↳ B-Negtv rng (2)
				↳ C-Negtv rng (2)
				↳ D-Negtv rng (2)
				↳ E-Negtv rng (2)
		↳ F-Negtv rng (2)		
		↳ G-Negtv rng (2)		
		Alarm	Break detect	
			XSDelta detect (25T only)	
			Latching alarm	
		Latch clear		
		Alarm direction		
		Suspect Input (not 25T)		
	Review	Model		
		Distributor		
		Manufacturer		
		Dev id		
		Tag		
		Message		
		Descriptor		
		Serial Number		
		Poll address		

		Num req preams
		Date
		Power Up Count
		Install Date
		Write Protect
		Universal Rev.
		Field Dev Rev
		Software Rev.
		Hardware Rev.
		DD Revision
PV		
%range		
AO		
Sensor1 (25T only)		
Sensor2 (25T only)		
CJ Temperature		
Delta (25T only)		
LRV		
URV		
Loop Controlled by (25T only)		
Loop Control Mode (25T only)		

**Figure 7 HART 5 DD Menu Structure
for STT25H and STT25T Configuration**

- ¹ Hysteresis, Damp-bumpless transfer are applicable to STT25T only and also depending on loop control option selected
- ² Depending on loop control option selected
- ³ Wire connection - for other variants than 25T, Applicable for RTD sensor type only
- ⁴ Compensation - Applicable for TC sensor type only
- ⁵ Damp bumpless transfer - applicable for STT25T in redundant and split range loop control options
- ⁶ RTD Adapter - Applicable only if sensor is RTD type

HART6 DD Menu Structure for STT25H, STT25S and STT25T Configuration

Device Setup	Process Variables	PV		
		%range		
		AO		
		Sensor1 (25T Only)		
		Sensor2 (25T Only)		
		CJ Temperature		
		Delta (25T Only)		
		LRV		
		MRV (25T Only)		
		URV		
		Loop Controlled by (25T only)		
		Loop Control Mode (25T only)		
		Bar chart for AO	PV AO %ge	
		Gauge charts	PV Gauge Chart	↳ PV Meter
			Sensor1 Gauge Chart (25T Only)	↳ Sensor1 Meter (25T Only)
			Sensor2 Gauge Chart (25T Only)	↳ Sensor2 Meter (25T Only)
			mA Gauge Chart	↳ mA Meter
		Trends	PV Trend	↳ Trend of PV
			CJ Trend	↳ Trend of CJ
			Sensor1 Trend (25T Only)	↳ Trend of S1
			Sensor2 Trend (25T Only)	↳ Trend of S2
			AO Trend	↳ Trend of AO

Device setup (continued)	Diagnostics	Device status	Critical 1		
			Critical 2 (25T only)		
			Non-Critical		
			Info		
			Device Status Image		
		Error Log	Error Log Flag		
			Show Error Log		
			Reset Error Log		
		Power Up Count	Power Up Count		
			Reset Power Up Count		
		Time In Service			
		Variables Monitoring	PV tracking	PV High-Low values	
				↳ PV Low Value	
				↳ PV High Value	
				PV High-Low Alm & Counter	
				↳ PV Low Alarm Limit	
				↳ PV Low Alarm Counter	
				↳ PV High Alarm Limit	
				↳ PV High Alarm Counter	
				↳ Change PV Alarm Limits	
				Reset PV Tracking Values	
			CJ Tracking	CJ High-Low values	
				↳ CJ Low Value	
				↳ CJ High Value	
				CJ High-Low Alm & Counter	
↳ CJ Low Alarm Limit					
↳ CJ Low Alarm Counter					
↳ CJ High Alarm Limit					
↳ CJ High Alarm Counter					
↳ Change CJ Alarm Limits					
Reset CJ Tracking Values					

Device Setup (continued)	Services	Master Reset		
		Loop Test		
		Write Protection	Write Protect	
			Write Protection On/Off	
			Change Password	
	Lock/Unlock Device			
	Calibration	Apply Values		
		Enter Values	LRV	
			URV	
			MRV (25T only)	
			LRL	
			URL	
		Correct Input LRV (Not 25T)		
		History of LRV corrects (Not 25T)	LRV Correct : Recent	
	LRV Correct : Previous			
	Calibration (continued)	Correct Input URV (Not 25T)		
		History of URV corrects (Not 25T)	URV Correct : Recent	
			URV Correct : Previous	
		Reset Corrects (Not for 25T)		
		D/A Trim		
Sensor Limit Values (25T only)				

Device Setup (continued)	Device Configuration	Install Date	
		Dev id	
		Model Number	
		Tag	
		Descriptor	
		Date	
		Message	
		Namur	
		Damp	
		Hysteresis band (25T only) ¹	
		Damp-Bumpless Transfer ¹ (25T only)	
		Poll Addr	
		Line Filter	
		Loop current Mode	
		LRV	
		MRV (25T only) ²	
		URV	
		Honeywell logo	
	Device image		
	Long Tag		
	Final Assembly number		
	Configuration Change Counter		
	Sensor Configuration	Sensor Selection (Not for 25T)	
		Sensor Type (Not for 25T)	
		Mode Selection (25T only)	
		Mode (25T only)	
		Sensor 1 Type Code (25T only)	
		Sensor 2 Type Code (25T only)	
		Select PV Unit (not 25T)	
		Select sensor Unit (25T)	
		Select CJ Unit	
		Wire Connection (Not for 25T) ³	
		Loop Control Mode (25T only)	
Compensation ⁴			
Delta (25T only)			
Delta Alarm (25T only)			
Match PV (25T only)			
Damp-Bumpless Transfer (25T only) ⁵			
Wiring diagrams			

Device Setup (continued)	Sensor Configuration (continued)	RTD Adapter (for S and H, it is only for 1 sensor) ⁶	Sensor1 Adapter		
			↳	RTD adapter 1 Selection	
			↳	Sensor1 +ve Coeffs	
			↳	B-Postv rng (1)	
			↳	C-Postv rng (1)	
			↳	D-Postv rng (1)	
			↳	E-Postv rng (1)	
			↳	F-Postv rng (1)	
			↳	G-Postv rng (1)	
				Sensor1 – ve Coeffs	
			↳	B-Negtv rng (1)	
			↳	C-Negtv rng (1)	
			↳	D-Negtv rng (1)	
			↳	E-Negtv rng (1)	
		↳	F-Negtv rng (1)		
		↳	G-Negtv rng (1)		
			Sensor2 Adapter		
			↳	RTD adapter 2 Selection	
			↳	Sensor2 +ve Coeffs	
			↳	B-Postv rng (2)	
			↳	C-Postv rng (2)	
			↳	D-Postv rng (2)	
			↳	E-Postv rng (2)	
	↳	F-Postv rng (2)			
	↳	G-Postv rng (2)			
	RTD Adapter (for S and H, it is only for 1 sensor) ⁶				

Device Setup (continued) Device Setup (continued)	Sensor Configuration (continued)	RTD Adapter (for S and H, it is only for 1 sensor) ⁶ (continued)	Sensor2 - ve Coeffs		
			↳	B-Negtv rng (2)	
			↳	C-Negtv rng (2)	
			↳	D-Negtv rng (2)	
			↳	E-Negtv rng (2)	
			↳	F-Negtv rng (2)	
			↳	G-Negtv rng (2)	
		Alarm	Break detect XSDelta detect (25T only) Latching alarm Latch clear Alarm direction Suspect Input (not STT25T)		
		Review	Model Distributor Manufacturer Dev id Tag Message Descriptor Serial Number Poll address Loop Current Mode Long Tag Final Assembly Number Config Change Cntr Num req preams Date Power Up Count Install Date Write Protect Universal Rev. Field Dev Rev Software Rev. Hardware Rev. DD Revision		

PV	
%range	
AO	
Sensor1 (25T only)	
Sensor2 (25T only)	
CJ Temperature	
Delta (25T only)	
LRV	
URV	
Loop Controlled by (25T only)	
Loop Control Mode (25T only)	

**Figure 8
HART 6 DD Menu Structure for STT25H, STT25S and STT25T Configuration**

- ¹ Hysteresis, Damp-bumpless transfer are applicable to STT25T only and also depending on loop control option selected
- ² Depending on loop control option selected
- ³ Wire connection - for other variants than 25T, Applicable for RTD sensor type only
- ⁴ Compensation - Applicable for TC sensor type only
- ⁵ Damp bumpless transfer - applicable for STT25T in redundant and split range loop control options
- ⁶ RTD Adapter - Applicable only if sensor is RTD type

4.5.4 HART Configuration (STT25T HART5/HART6 Models)

1. Turn on the power supply and the HART Communicator.
2. On power up, the communicator will display "**375 Field Communicator**" or "**475 Field Communicator**". Then select "**HART Application**" and -> to search for devices. When devices are found they will display as "**STT250: xxxxxxxx**" (xxxxxxx represents the tag) and "**On-line**".
The process values (PV1, PV2), Delta (PV1- PV2) and % Range are displayed a few seconds later.

NOTE: Even though the transmitter is working properly, the HART Communicator may display "Input Open".

- Press "**NEXT**". "**Sensor 1 failed or Sensor 2 failed**" message (or both) is displayed.
- Press "**NEXT**" again. "**Ignore next 50 occurrences of status**" is displayed.
- Confirm with "**YES**" to correct the problem.

The cause is probably one of the following:

- ⇒ You have not connected a sensor to the input.
- ⇒ There is an open circuit in the sensor, connecting wiring or terminal connections.
- ⇒ You have connected a T/C or other milli-volt source to the T/C terminals and the transmitter is configured for RTD input (or vice versa).



3. Press → to select "**Device setup**" menu.
4. Select an appropriate menu to access transmitter parameters and settings
As mentioned earlier, the default shipping mode for units is -20 to 150 mV input, -20 to 150 mV range.

You can now customize the unit to your specific application. The flow chart in Figure 7 HART 5 DD Menu Structure for HART 5 and Figure 8 for HART 6 DD Menu Structure for STT25T Configuration gives a simplified overview of selections and key strokes.

- In summary:
- pressing → selects a menu,
 - pressing ↑ or ↓ accesses the selections of any category,
 - pressing ← steps back to the previous menu.

4.5.4.1 Examples of configuring dual and TC/TC input modes

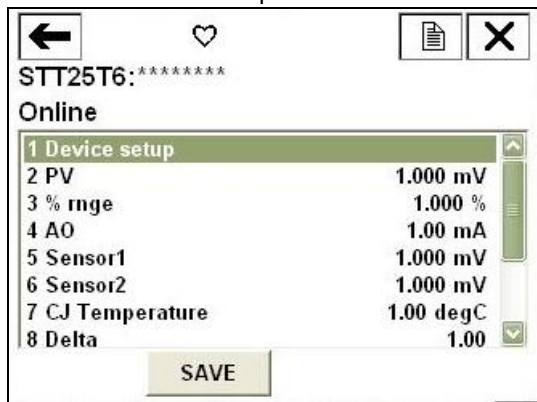
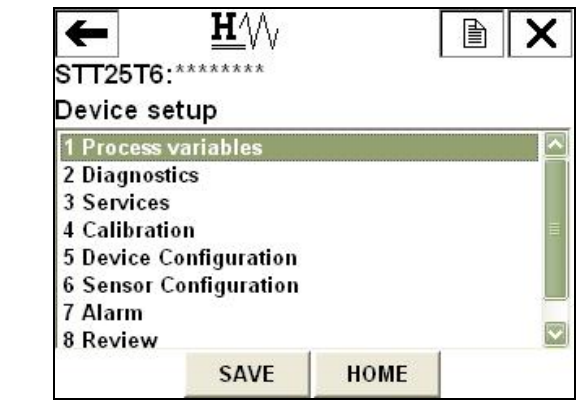
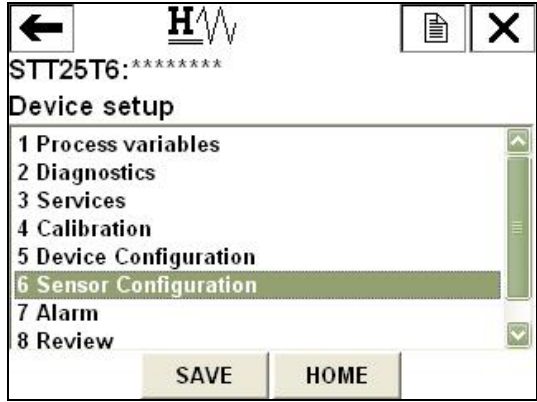
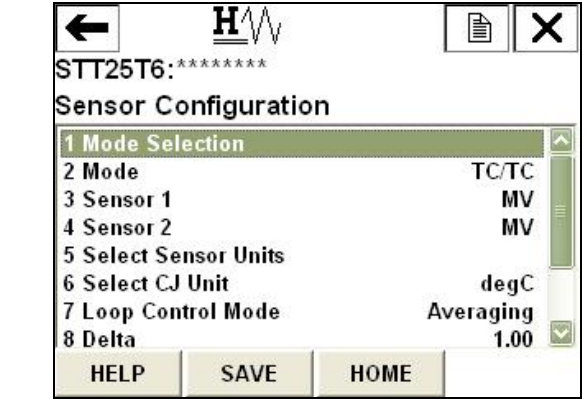
EXAMPLE: How to configure the transmitter in TC/TC sensor cross-checking mode with a delta alarm value set and linked to an alarm level on the loop

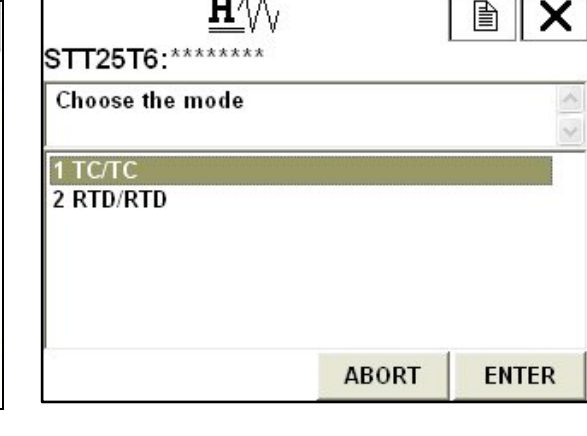
<p>1. When device is loaded, following screen is viewed initially. Press 1 (or press →) to select Device setup.</p> 	<p>2. Following screen is viewed.</p> 
<p>3. Press 6 (or use DOWN arrow key) to select Sensor Configuration.</p> 	<p>4. First menu on this page is Mode selection. Press 1 (or→) to enter this method.</p> 
<p>5. Warning will be displayed. Press OK.</p> 	<p>6. Select TC/ TC mode and press ENTER.</p> 

7. Select Sensor 1 & Sensor 2 type code (say TC K).

8. Select unit for PV (say deg C).

9. Warning will be displayed. Press OK.

10. Verify on sensor configuration menu that mode is TC/TC, sensor1 & sensor2 are TC K.

11. In sensor configuration menu, press DOWN arrow key 10 times to reach Delta Alarm. Press → to enter.

12. Enter desired value of Delta Alarm. Hit ENTER.

13. You will come back to Sensor configuration menu. A star is indicated on left hand side of Delta Alarm. It means that this value is not sent to the device. Press SEND button to change the configuration of device.

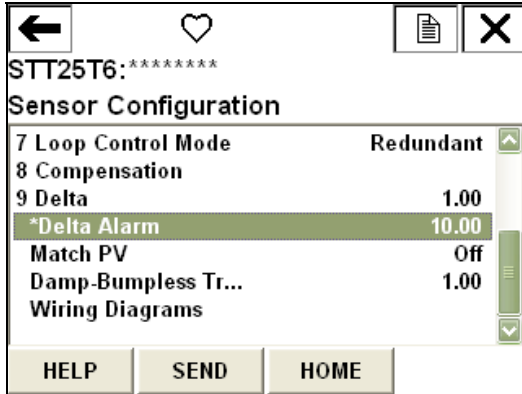

14. Now, press ← to return to Device Setup menu. Press 7 (or use DOWN arrow key) to reach to Alarm.

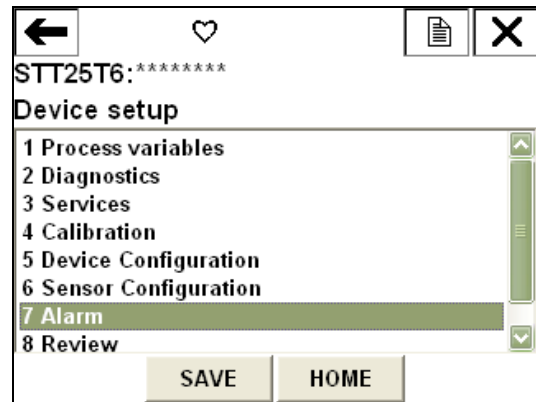

15. In the alarm menu, option 1 is XSDelta detect. (NOTE: Make sure that device' loop control mode is Redundant mode. XS Delta Detection is not displayed in other Loop control modes.) Press → to enter.

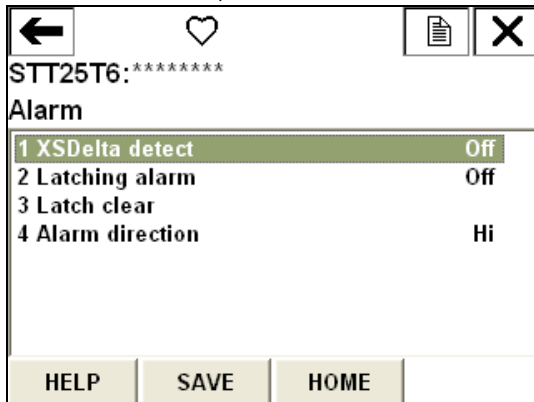

16. Make this detection ON. Hit ENTER.

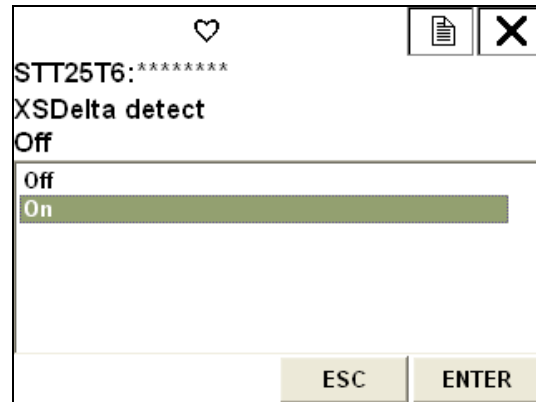

17. Now, send this to device.



Verify that this value is sent and alarm is ON.



In the examples above the Device is now configured to have both inputs as TC K type. The Device is in redundant mode, so both sensors are at the same location. The read-out will be the same for sensor1 and sensor2. If one of the sensors degrades and starts showing erroneous values, the difference between 2 sensors goes above the configured limit to 10, XSDelta detect will be set ON. The device in example is in redundant mode and XS Delta detect is ON, so the device will switch to sensor2 and if sensor2 is ok, the device will function normally. If sensor2 is also "bad", the device current value will be set to burnout value.

4.6 Mounting

4.6.1 DIN Rail Mounting

If the STT250 is to be installed on DIN Rail then the main considerations are electrical connections and mechanical fixing. Electrical connections are identical to the bench test instructions (Section 4.3) except that thermocouple wire is likely to be used with thermocouples. Mechanical fixing of the module is by means of the snap-in DIN Rail Clips which are screwed to the bottom lugs of the module.

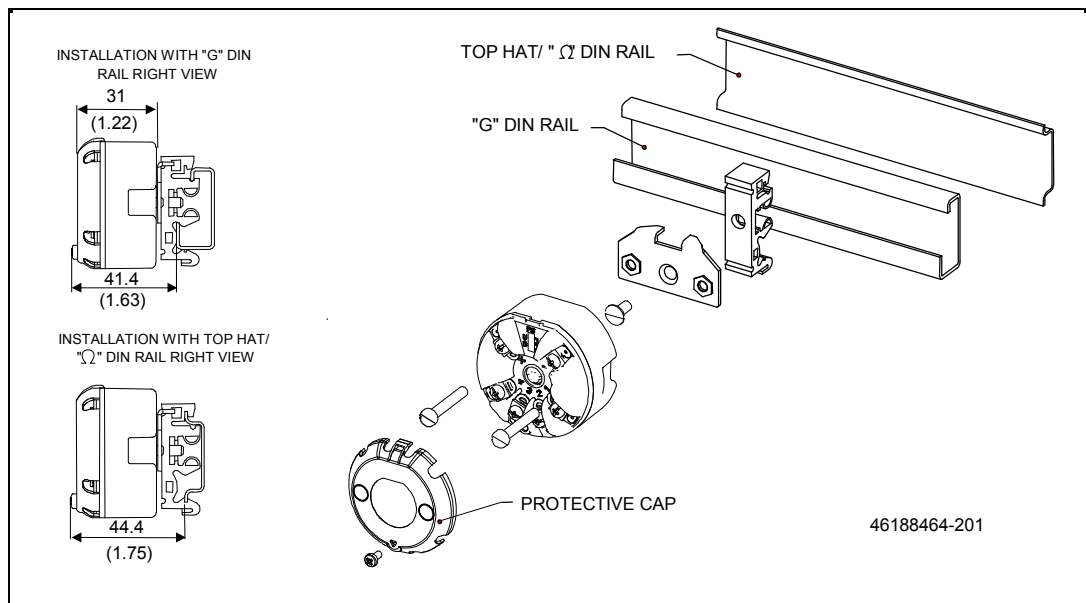
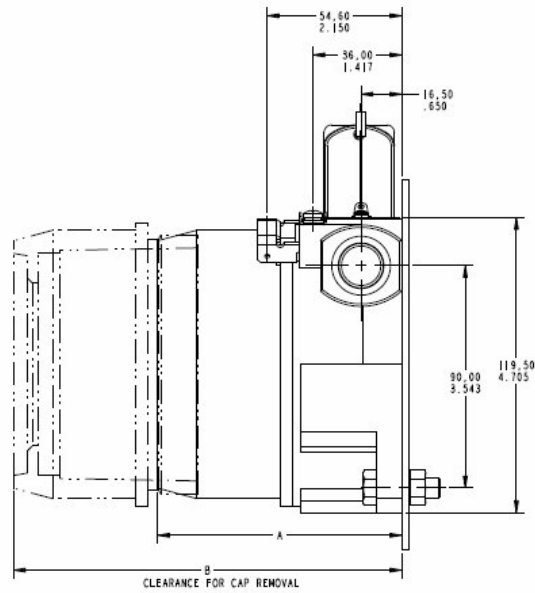

Figure 9: DIN Rail Mounting

4.6.2 Mounting Module in Housing

The STT250 module can be installed in a variety of housings suitable for direct head mounting, 2" (50mm) pipe mounting or wall mounting. Ensure that the installation location is suitable for reliable transmitter operation (e.g. for high temperature applications, a thermowell extension is recommended to minimize failure rates due to high ambient temperatures near the transmitter).



**FIELD MOUNT HOUSING WITH METER
RIGHT VIEW**

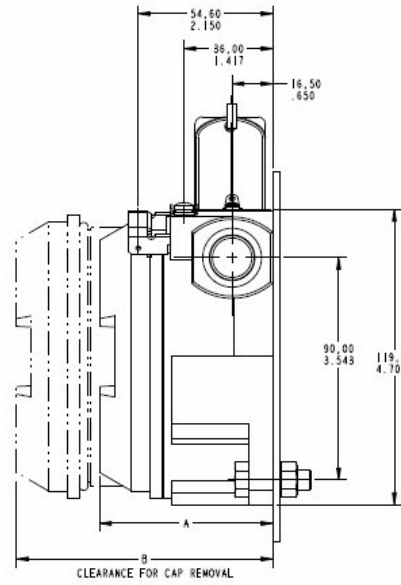

**FIELD MOUNT HOUSING WITHOUT METER
RIGHT VIEW**

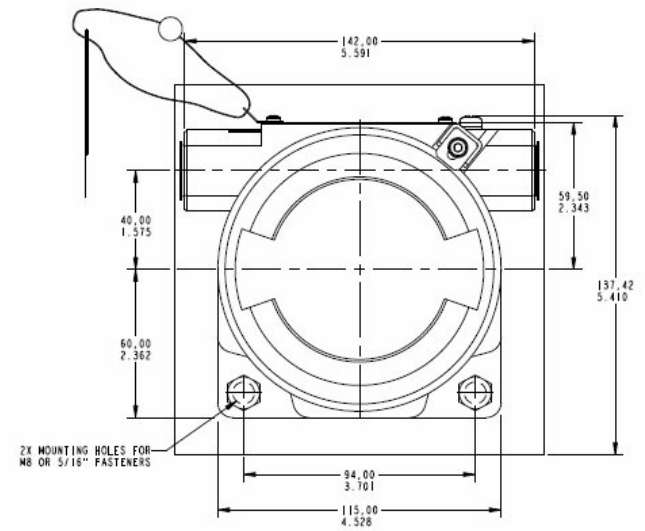

**FIELD MOUNT HOUSING WITH AND WITHOUT METER
FRONT VIEW**

Figure 10: Wall Mounting Dimensions

See table below for Dimensions A & B

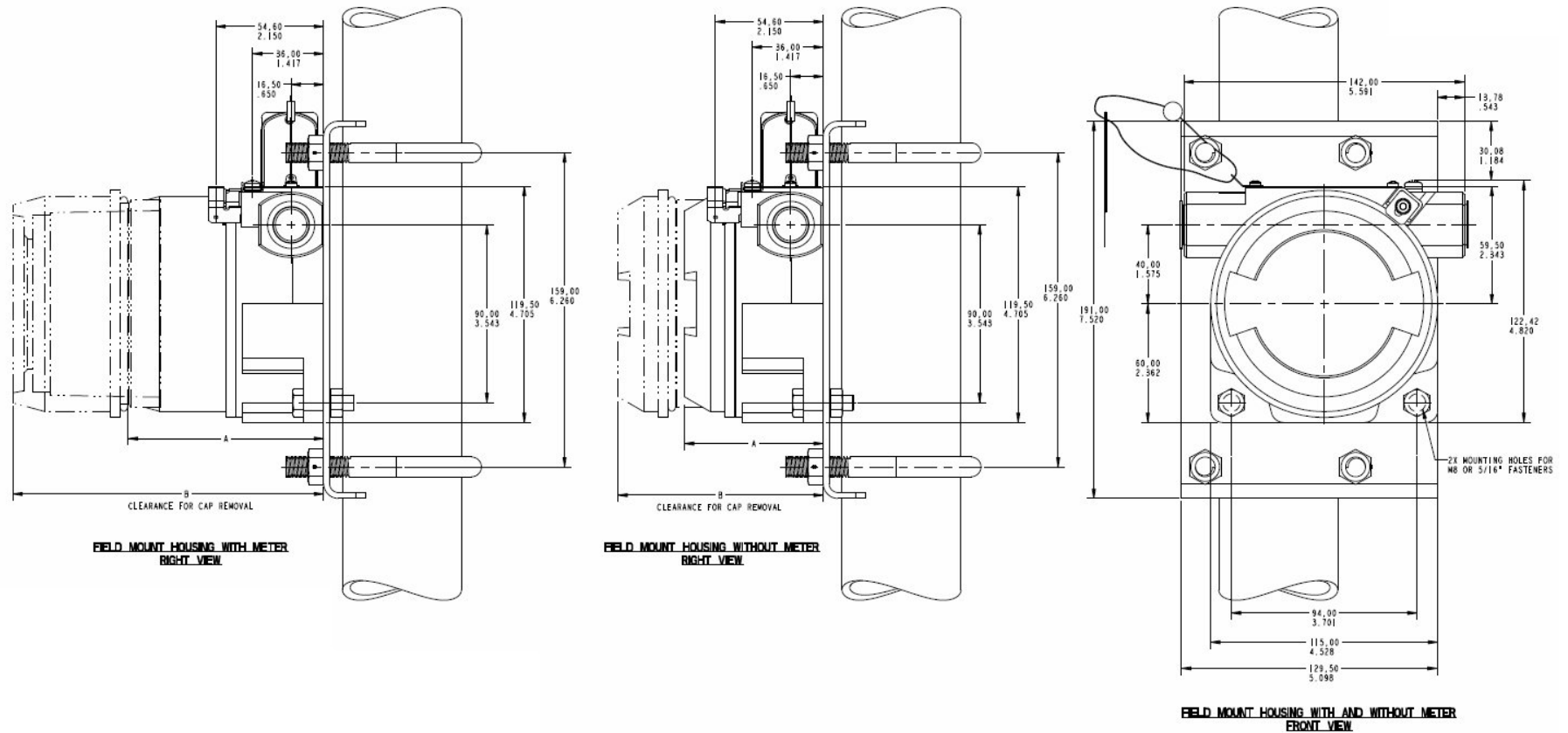

Figure 11: Pipe Mounting Dimensions

See table below for Dimensions A & B

**Dimensions for
Figure 10 & Figure 11**

Dimensions	Aluminium		Stainless Steel	
	A	B	A	B
Without integral meter	70.30 mm [2.768 inch]	104.00 mm [4.094 inch]	99.00 mm [3.898 inch]	157.50 mm [6.201 inch]
With integral meter	99.00 mm [3.898 inch]	157.50 mm [6.201 inch]	99.00 mm [3.898 inch]	157.50 mm [6.201 inch]

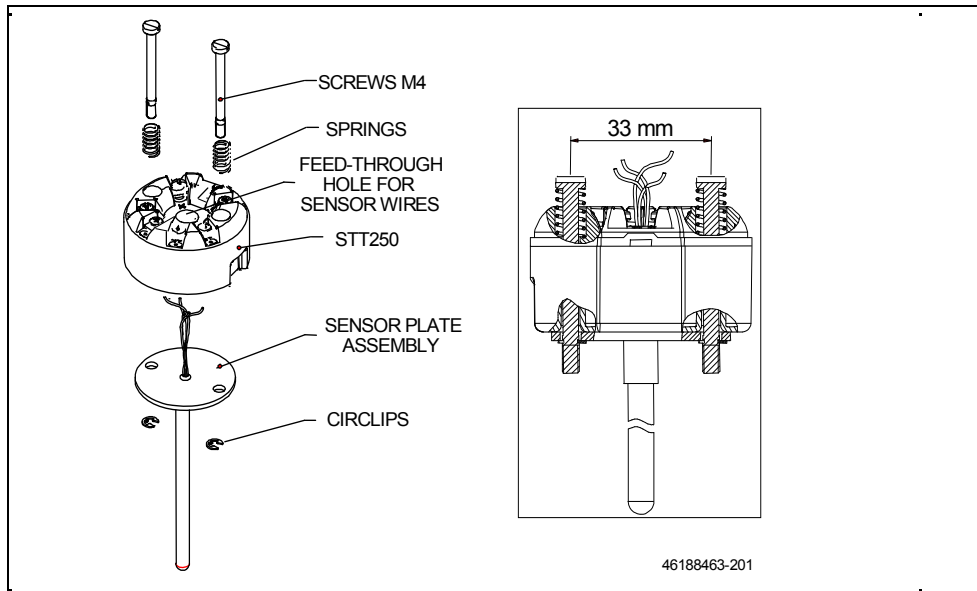

Figure 12: Spring Loading and Sensor Assembly

Spring loading is available worldwide with direct head mounting. In North America, the spring loading is typically included in the sensor/thermowell assembly and is available with all housings. For non-North American spring loading as shown in Figure 12, simply include the springs under the 33 mm pitch mounting screws, pass the screws through the module and sensor mounting plate and snap in the retaining circlip to the screws to hold the assembly together. Guide the sensor assembly through the housing sensor entry and screw down the 33 mm screws until the limit is reached as the sensor presses against the bottom of thermowell.

For wall or 2" pipe mounting, the temperature sensor can be remote from the STT250 field mount housing or integral to the housing. For remote installations, the sensor wiring should be run in shielded, twisted pair wiring and connected via one of the housing wiring entries. For explosionproof/flameproof installations, ensure that the cable entries are fitted with flameproof adaptors and that the wiring grade complies with local standards.

Note that for internal spring loading applications including flameproof requirements, the direct head mount housing should be ordered with the sensor to incorporate the flame trap. Then connect the sensor wiring to the appropriate input terminals. Ensure that you have selected the desired failsafe link direction (up/down). Connect the output 2 wire signal to power connections. Screened, twisted pair wiring is recommended but not essential. The connection route to the receiving device may be run in multicore cable without any cross talk concerns for either HART or DE protocol units.

However, ensure that no digital I/O signals co-exist in the same multicore as HART protocol signals since these signals can cause interference. Galvanic isolation of input/output circuits enables use with grounded or ungrounded probes. This enables connection of the output signal to ground (e.g. at safety barriers), without creating a ground loop. Screw down the housing cover securely.

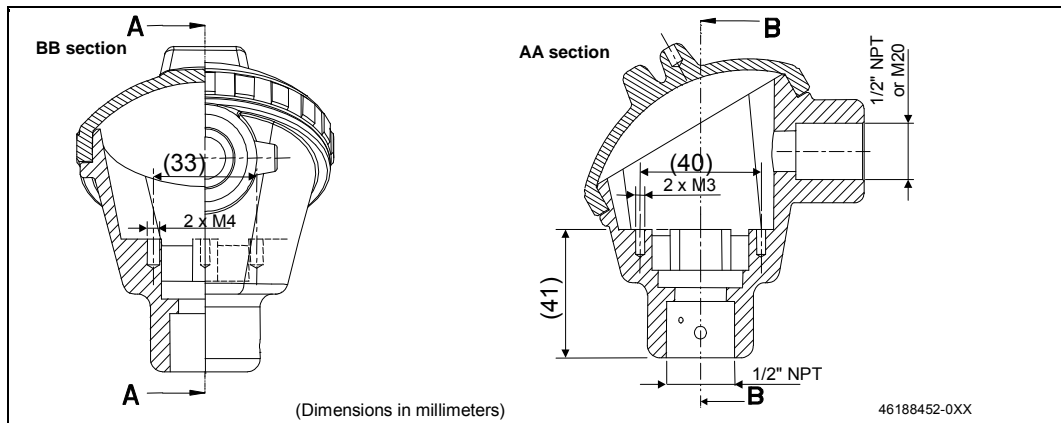

Figure 13: Aluminium Direct Head Mount Housing Dimensions

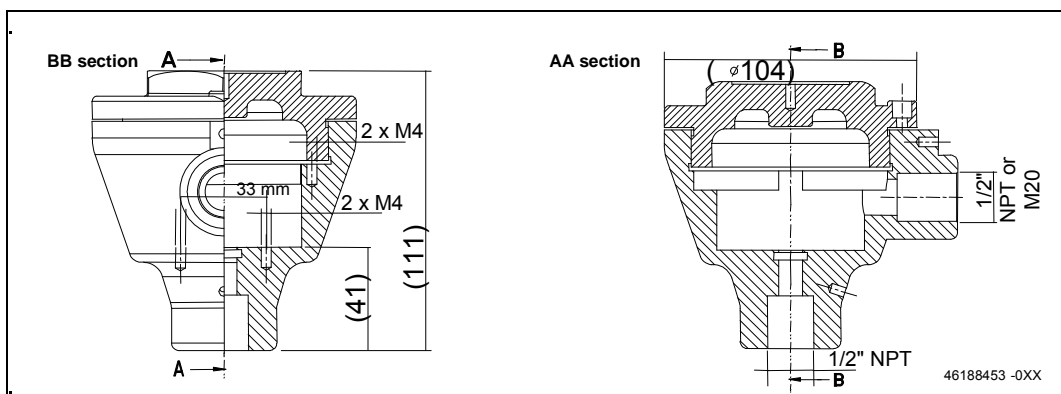

Figure 14: Cast Iron Direct Head Mount Housing Dimensions

For more detailed installation drawings, refer to the list in section 5.4.

4.7 Commissioning

Commissioning is carried out after installation and wiring have been completed. Power up the STT250 transmitter and verify via the SFC or HART Communicator that it is configured as required. If a bench check and configuration were completed, the procedure will be clear. If no bench check and configuration was done, refer to Section 4.4 and carry it out now. Verify also that the receiving device is actually receiving the output signal and use the SFC or HART Communicator in output mode to vary the output signal and verify loop calibration. If small errors exist in the loop then they should be identified and the out of specification device calibrated. However, if no adjustment is possible (e.g. with voltage developing resistors or active barriers) then the STT250 output can be recalibrated to compensate for loop zero and span errors. For calibration of the STT250, refer to the SFC Operating Guide 34-ST-11-16.

4.8 Start Up

Start up the process, check that the STT250 environment is still as expected (i.e. local temperature and vibration are not excessive), housing cover is tightly sealed and mountings are secure.

If the process operates at a slightly different condition from expected then the range of the STT250 can be easily changed by keying in a new URV/LRV setting via the SFC(DE) or the HART Communicator and rescaling the receiving device.

4.9 Advanced Diagnostics

4.9.1 Install Date

Install date is written at the time of installation. Once it is written by the installation engineer, it will be read only after that.

4.9.2 Time in service

Minutes counter will be maintained in device NVM which will be provided to host application. Time in Service value will start accruing from the time of initial power-up at the customer site.

4.9.3 Error Log

Log of recent critical errors will be maintained in device NVM. Last 10 critical errors will be recorded in this log. Host application will display the meaning of these errors.

- Hardware Failure
- Input open
- Factory calibration corrupted
- User configuration corrupted
- XS Delta – Critical (STT25T only)
- Watchdog reset
- Ambient temperature out of range
- Cold start bit set – Power cycle

4.9.4 Calibration records

Last 2 calibration dates and times for LRV, URV and Input calibration will be recorded in device NVM in the format as MM/DD/YYYY, HH/MM/SS.

4.9.5 Power up diagnostics

The count of how many times power fail occurred will be evaluated and time since last power on will be stored in NVM.

4.9.6 PV / SV monitoring

The variables listed below will be stored in NVM:

- Number of times PV/SV exceeded user-configured alarm limits.
- Maximum/minimum PV/SV
- A timestamp indicating the last time the PV/SV exceeded the user-configured alarm limits.

4.9.7 Sensor short detection (only for RTD)

An informational status indicating that a connected RTD sensor has failed due to a short fault.

4.9.8 Model number

Displays the ordering Model Number of the device

4.9.9 Serial number

Displays the serial number of the device

4.10 Enhanced DD

All the DDs for new STT250 series transmitters are enhanced DDs. Enhanced DD means the DDs use the latest DD technology of using classic GUIs and different enhancements like graphs, charts, images, trends etc. The STT250 series DDs have now all these things implemented to simplify the user understanding about the process behavior in the simplest possible ways.

Make a note that these features are host dependent and display of those may vary host-to-host. (e.g. Trends, gauge charts look differently on MC-Toolkit and 375/475. Also the features related to it like zoom in/out, shifting on X-Y axis etc. may be provided by some hosts but may not be by others.)

The used Enhanced DD features are summarized as given below:

4.10.1 Status Indication

It shows device's overall status i.e. good, bad or warning. Whenever any Critical status flag sets, "Bad" image is shown. When PV gets saturated or input is out of specifications, the "Warning" image is shown; else "Good" image is shown. The images are as shown below:



Good



Bad



Warning

The location to view these images is:

Online → Device Setup → Diagnostics → Device Status → Device Status Image

4.10.2 Manufacturer logo and Device Image

Manufacturer logo and device images are now included as a part of DD as shown below:



Device Image

Honeywell Logo

The location to view these images is:

Online → Device Setup → Device Configuration → Manufacturer Logo

Online → Device Setup → Device Configuration → Device Image

4.10.3 Wiring Diagrams

Sensor wiring diagrams are included in the STT250 series DDs to quickly give user, an idea about the sensor wirings to be done. It is as shown below:

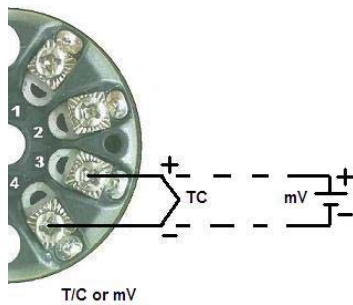
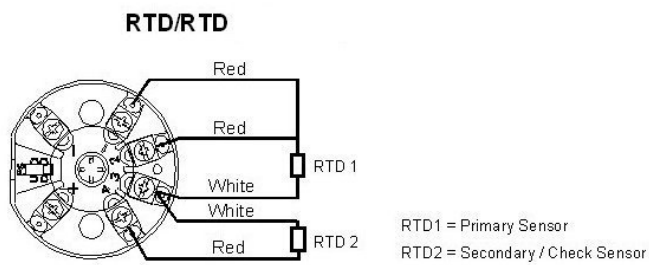
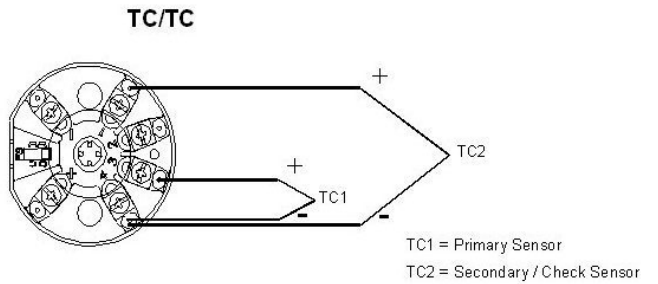

The location to view these images is:
Online → Device Setup → Sensor Configuration → Wiring Diagrams

4.10.4 Trend Charts

Trend charts are used as the part of DDs, to show the continuous variations in the process values as shown below:

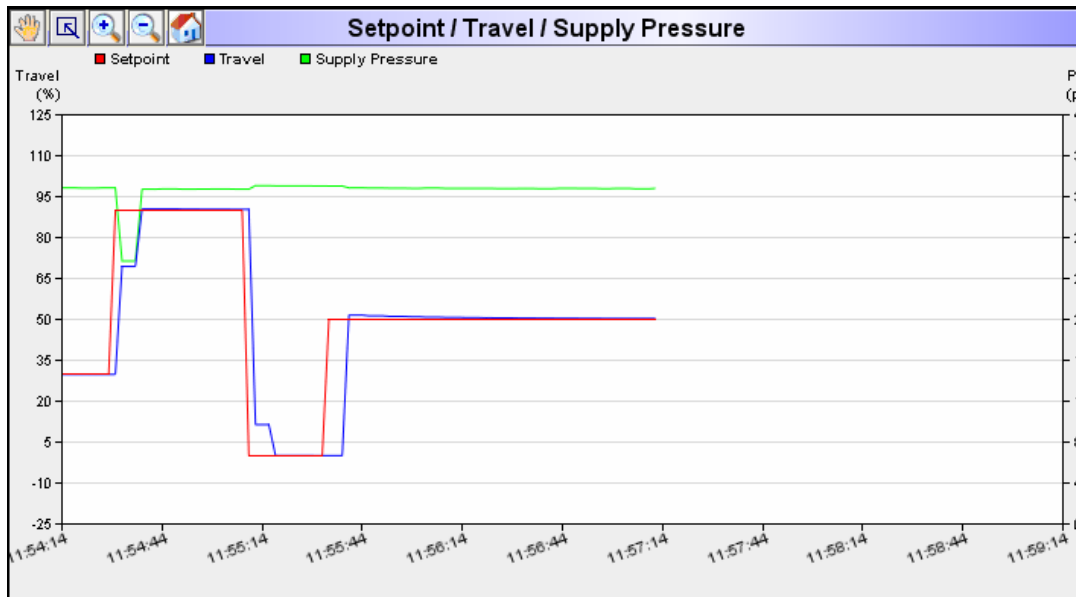

The location to view these charts is:

Online → Device Setup → Process Variables → Trend Charts

4.10.5 Gauge charts

Gauge charts are used to display different values in the form of analog meters, as shown below:

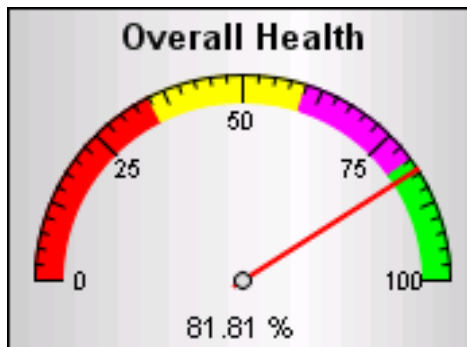

The location to view these charts is:

Online → Device Setup → Process Variables → Gauge Charts

4.10.6 Horizontal bar chart

Horizontal bar charts are used to show the % range of PV value, as shown below:

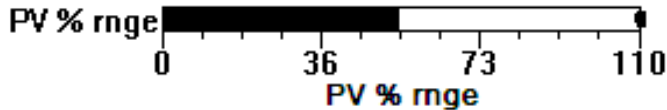

The location to view this chart is:

Online → Device Setup → Process Variables → Bar chart for AO

4.11 CVD coefficients for RTD

RTD sensors with Callendar – van Dusen coefficients are expensive and they are used in critical applications. For other applications normal sensor is used. To get improved RTD accuracy, RTD sensors with CVD coefficients can be used.

If RTD sensor with Callendar – van Dusen coefficients to be used, the RTD Adapter option has to be enabled. After enabling this option, the Callendar – van Dusen coefficients for the respective RTD sensor must be used to calculate the RTD Adapter constants required to be stored in device NVM for improved RTD accuracy. A Microsoft Excel utility provided by Honeywell, is required to generate these RTD Adapter constants. Using this utility, total 14 constants - 7 for positive RTD range and 7 for negative RTD range are generated. Different commands are provided for enable/disable of RTD Adapter option and for entering these constants to the device NVM storage.

For STT25T model, if both the sensors are RTD type then two sets of these constants are required to be generated and used appropriately for the respective sensor. The STT25T model is provided with additional commands to enter these RTD Adapter constants to the device NVM storage for both the RTD sensors.

The RTD Adapter feature is available for all STT250 HART models using RTD as sensor.

* CVD (Callendar-Van Deusen)

5. MAINTENANCE/TROUBLESHOOTING

5.1 Maintenance

Maintenance of the STT250 is limited to ensuring that connections, seals and mounting are tight and secure. There are no moving parts or adjustments, thus, the only reason to open the housing is to inspect for corrosion or conductive dust entry which could later affect reliable operation.

WARNING→ The transmitter module itself should NEVER be opened.

5.2 Troubleshooting

5.2.1 Troubleshooting with SFC (STT25M and STT25D Models)

Troubleshooting the STT250 loop is greatly simplified by connecting the SFC in the termination area near the receiving instrument. Also connect a DVM, at the termination area for the receiving instrument, to confirm a similar signal is coming from the field and power is available on the two wires of the 4-20 mA loop. This isolates the problem to either field loop or receiving instrument/power supply/wiring/safety barriers etc. If the original symptom was an unstable input, it could be a loose connection on the receiving side. Assuming the above confirms a field loop problem, the likely causes/actions are given below.

For any step the first action is to hook up the SFC to the transmitter and press "ID", then "STATUS".

SYMPTOM	SFC MESSAGE/ DISPLAY	POSSIBLE CAUSE	CURE
No input or low input	"INPUT OPEN" (with downscale fail-safe) "I/P OUT OF SPEC" (indicates that the input is below LRL) "HI RES/LO VOLTS" which indicates an open circuit loop	Bad sensor wire connection. Incorrect operating voltage.	Check out field wiring and connections. Ensure that the transmitter is in its voltage operating area. Verify that the 250 ohms resistor is in loop.

SYMPTOM	SFC MESSAGE/ DISPLAY	POSSIBLE CAUSE	CURE
High input	<p>"INPUT OPEN" (with upscale fail-safe)</p> <p>"I/P OUT OF SPEC" (indicates that the input is above URL or below LRL)</p>	<p>Bad sensor wire connection.</p> <p>Incorrect operating voltage.</p>	<p>Check field wiring and connections for partial short circuit.</p> <p>Check STT250 connections are correct polarity.</p> <p>Check that the transmitter is in its voltage operating area and line resistance is not excessive.</p>
Unstable onscale input	<p>"STATUS CHECK = O.K." since any identified problem would give upscale or downscale fail-safe.</p>	<p>Bad sensor wire connection.</p> <p>Intermittent open circuit of sensor.</p> <p>Wiring disturbed by strong electromagnetic interference.</p>	<p>Check connection and wiring for intermittent connections.</p> <p>Check that sensor fault detection is "ON", this allows detection of a bad sensor.</p> <p>Protect wiring by using appropriate grounding, shielding etc.</p>
Fail-safe output signal	<p>"CRITICAL STATUS"</p>	<p>A fail-safe output signal (critical status) can be caused by several reasons.</p>	<p>The SFC will indicate the source of the problem by displaying the appropriate error message.</p>

SYMPTOM	SFC MESSAGE/ DISPLAY	POSSIBLE CAUSE	CURE
Incorrect output signal with simulating device	"STATUS CHECK = O.K." but does not correspond to value set by simulating device	The most common error is changing the sensor wiring after probe type selection or after power-up.	Check the appropriate sensor wiring and power cycle when it is correct. Remember when changing configuration to first connect sensor wiring correctly, then change configuration.
"INVALID REQUEST" when changing LRV or URV	"INVALID REQUEST"	If the LRV is changed, the URV tries to change by the same amount to maintain the same SPAN. If this new URV exceeds the URL then this message appears.	Reduce the URV or SPAN before changing the LRV.
Non-critical status message, without # sign	"USER CORR ACTIVE"	Transmitter has been trimmed for particular sensor range. This can be done by keying in LRV/URV, CORRECT, ENTER with exact LRV and URV input values to enable improved accuracy over the specifications.	When performing a Reset Correct command or a sensor type change, the transmitter will lose this sensor correction and fall back to the original factory calibration.
<p>Remember that successful communications with the STT250 result in many useful pieces of data. With the initial I.D. response, the user can confirm that the:</p> <ol style="list-style-type: none"> 1. Transmitter is powered 2. Line resistance is correct 3. Wires run to the correct unit. If not, the unit connected can be identified by the tag number. 			

5.2.2 Troubleshooting with HART communicator (STT25H, STT25S, and STT25T Models)

SYMPTOM	HART communicator MESSAGE/ DISPLAY	POSSIBLE CAUSE	CURE
<p>Remember that successful communications with the STT250 result in many useful pieces of data. With the initial I.D. response, the user can confirm that the:</p> <ol style="list-style-type: none"> 1. Transmitter is powered 2. Line resistance is correct 3. Wires run to the correct unit. If not, the unit connected can be identified by the tag number. 			
Overview			
Incorrect output signal with simulating device	None	The most common error is changing the sensor wiring after probe type selection or after power-up.	Check the appropriate sensor wiring and power cycle when it is correct. Remember when changing configuration to first connect sensor wiring correctly, then change configuration.
When changing LRV or URV	"VALUES TOO HIGH OR TOO LOW"	If the LRV is changed, the URV tries to change by the same amount to maintain the same SPAN. If this new URV exceeds the URL then this message appears.	Make sure that: LRV >= LRL and that URV <= URL
Status is set to "USER CORR ACTIVE" (STT25H and STT25S)	"USER CORR ACTIVE"	Transmitter has been trimmed for particular sensor range. This can be done by keying in LRV/URV, CORRECT, ENTER with exact LRV and URV input values to enable improved accuracy over the specifications.	When performing a Reset Correct command or a sensor type change, the transmitter will lose this sensor correction and fall back to the original factory calibration.

SYMPTOM	HART Communicator MESSAGE/ DISPLAY	POSSIBLE CAUSE	CURE
High input	"I/P OUT OF SPEC" (indicates that the input is above URL or below LRL)	Incorrect operating voltage.	Check STT250 connections are correct polarity. Check that the transmitter is in its voltage operating area and line resistance is not excessive.
Unstable onscale input	None Since any identified problem would give upscale or downscale fail-safe.	Bad sensor wire connection. Intermittent open circuit of sensor. Wiring disturbed by strong electromagnetic interference.	Check connection and wiring for intermittent connections. Check that sensor fault detection is "ON", this allows detection of a bad sensor. (This option is not available on STT25T) Protect wiring by using appropriate grounding, shielding etc.

SYMPTOM	HART Communicator MESSAGE/ DISPLAY	POSSIBLE CAUSE	CURE
Critical status A fail-safe output signal can be caused by several reasons. The HART communicator will indicate the source of the problem by displaying the appropriate error message.			
Fail-safe output signal	"HARDWARE ERROR"	An internal problem linked to the device's electronics is causing a bad measurement calculation.	Try to restart the device. If the problem persists, contact your vendor.
Fail-safe output signal	"NVM CALIB FAILED"	The diagnostic of the calibration area stored in the non volatile memory has failed	Try to restart the device. If the problem persists, perform a Master Reset and re-calibrate the device.
Fail-safe output signal	"NVM CONF FAILED"	The diagnostic of the configuration area stored in the non volatile memory has failed	Try to restart the device. If the problem persists, contact your vendor.
Fail-safe output signal	"SENSOR FAIL" Refer to : Table 1 - When « SENSOR FAIL » is set in STT0	Bad sensor wire connection. The two sensors are broken or badly connected (STT25T only)	Check for incorrect field wiring and connections or for partial short circuit.
Fail-safe output signal	"XS DELTA - CRITICAL" (STT 25T only)	The value of delta (delta = PV1-PV2) is higher than the alarm level set by the user AND the option "XS delta detection" has been turned ON.	The transmitter works in ambient temperature conditions out of its specification, but the measurement quality may be degraded.

SYMPTOM	HART Communicator MESSAGE/ DISPLAY	POSSIBLE CAUSE	CURE
Non-Critical status			
The HART communicator can indicate some problems or information by displaying messages which are not associated to a fail-safe output signal, these are "non-critical-status"			
The following message is displayed	"CJ OVER TEMP"	The ambient temperature measured is out of the transmitter specifications (-40°C to 85°C or -41°F to 185°F)	The transmitter works in ambient temperature conditions out of its specification, the measure can be perverted
The following message is displayed. Output fixed at 20.8 or 3.8 mA. (20.5 if NAMUR)	"OUTPUT SATURATED"	PV > URV or PV < LRV	Check your process temperature. Adapt the span.
The following message is displayed	"IN OUTPUT MODE"	The output is fixed at a specific value and not representing the applied input.	Clear output mode to return to normal operation.
The following message is displayed	"SENSOR1 FAILED" (STT25T only)	Sensor 1 is not reporting a valid input and may be broken.	Check the wiring for Sensor 1 and test for failure.
The following message is displayed	"SENSOR2 FAILED" (STT25T only)	Sensor 2 is not reporting a valid input and may be broken.	Check the wiring for Sensor 2 and test for failure.
The following message is displayed	"XS DELTA NON CRITICAL" (STT25T only)	The value of delta (delta = PV1-PV2) is higher than the alarm level set by the user AND the option « XS delta detection » has been turned OFF	If you do not want to see this non critical-status, change delta alarm value.
The following message is displayed	"INPUT OUT OF SPEC"	Check sensor wiring connections and invalid operating voltages for the device	Check sensor is ok and to the sensor wiring connections and device operating conditions.

SYMPTOM	HART Communicator MESSAGE/ DISPLAY	POSSIBLE CAUSE	CURE
Critical Statuses (these apply only for SIL approved units):			
Fail-safe output signal	RAM FAILURE	The device has detected corruption in a RAM memory location.	Try to restart the device. If the status persists, contact your vendor.
Fail-safe output signal	ROM FAILED	The device has detected corruption in a ROM memory location.	Try to restart the device. If the status persists, contact your vendor.
Fail-safe output signal	FLOW CONTROL FAULT	The device has detected an interruption in the proper flow of functional operations.	Try to restart the device. If the status persists, contact your vendor.

SYMPTOM	HART Communicator MESSAGE/ DISPLAY	POSSIBLE CAUSE	CURE
Informational Status			
The following message is displayed	INPUT OPEN (1/2)	The device is indicating an open connection for sensor input. For STT25T devices, the relevant input will be specified (Input 1 or Input 2)	Verify the applicable sensor wiring and check the sensor for failure.
The following message is displayed	RTD SHORT (1/2)	The device is indicating a shorted connection for an RTD sensor input. For STT25T devices, the relevant input will be specified (Input 1 or Input 2)	Verify the applicable sensor wiring and check the sensor for failure.

Table 1 - When « SENSOR FAIL » is set in STT250

No.	Condition	Status Messages
1	Input is MV OR TC type & in Open state.	> Critical - Sensor fail > Info - Input Open
2	Input is RTD or OHM type and is in open state (any of 3 wires OR sensor itself)	> Critical - Sensor fail > Info - Input Open
3	Input is RTD or OHM type and is in shorted state	> Critical - Sensor fail > Info - RTD Short

5.3 Recommended Parts

GENERAL DESCRIPTION:	Reference
STT250 Electronics Module	Order from the Model Selection Guide to include options as required.
METERS	
Replacement Smart meter	30757178-501
Replacement Analog meter	30756997-501
Meter mounting bracket kit	46188056-502
Diode for Analog Meter	46188432-501
HEAD MOUNT HOUSINGS (Cable/Conduit entry noted. All have ½" NPT sensor entry)	
Aluminium head mount housing (M20)	46188452-501
Aluminium head mount housing (1/2"NPT)	46188452-502
Flame proof cast iron head mount housing (M20)	46188453-501
Flame proof cast iron head mount housing (1/2"NPT)	46188453-502
FIELD MOUNT HOUSINGS (All have ½" NPT sensor and cable/conduit entries)	
Field mount housing base - Aluminium beige epoxy-polyester hybrid painted	46188472-501
Field mount housing end cap - Aluminium beige epoxy-polyester hybrid painted	30752006-501
Field mount housing meter cap - Aluminium beige epoxy-polyester hybrid painted	30755956-501
Field mount housing base - Aluminium beige epoxy painted	46188472-502
Field mount housing end cap - Aluminium beige epoxy painted	46188471-501
Field mount housing meter cap - Aluminium beige epoxy painted	46188471-502

MISCELLANEOUS PARTS	
Adaptor plate to install module in field mount housing	46188423-501
Accessories kit (DIN rail clip, terminal screws, fail-safe link, spring loading mounting set)	46188465-501
Spring loading mounting set	46188416-501
DIN rail mounting clip (top hat/"Ω" or "G" rail)	46188431-501
Carbon steel mounting bracket for 2" pipe (for use with field mount housing)	30755905-001
Stainless steel mounting bracket for 2" pipe (for use with field mount Housing)	30671907-001
1/2"NPT to M20 x 1.5 conduit adaptor (flameproof EEx d)	46188203-501 46188203-001
1/2"NPT to 3/4"NPT conduit adaptor	51196567-501 51196567-001
Transient protector (external to housing)	30755970-501
Stainless steel wired-on customer ID tag	46188051-001
Surge Protector	46188660-001
LITERATURE	
SFC operating card	34-ST-11-16
English operator manual	EN1I-6190
French operator manual	FR1I-6190
Spanish operator manual	SP1I-6190

5.4 Wiring and Installation Drawings Numbers

FM external wiring diagram	46188466-201
CSA external wiring diagram	46188466-202
Meter connections	46188461-201
Spring loading and sensor assembly	46188463-201
Pipe mounting dimensions	46188468-201
Wall mounting dimensions	46188467-201
Typical wiring of transient protector to STT25_ transmitter	46188469-201
DIN rail mounting	46188464-201
Aluminium direct head mount housing	46188452-0XX
Cast-iron direct head mount housing	46188453-0XX

6. INDICATION METERS

6.1 Introduction

Integral meters are supplied already installed by the factory and provide a display of the transmitter output. Table II selection __ M gives a 4-20 mA analog output on a moving coil display to $\pm 2\%$ accuracy. A diode fitted across the meter enables loop continuity in the event of a moving coil failure. To ensure adequate loop power availability in this event, add 0.7 V power supply to the loop in addition to 10.8 V for the transmitter (i.e. 11.5 V minimum supply Volts).

Table II selection __ S is the Smart Meter with LCD which accepts either the Digital DE or the 4-20 mA analog signal. Regardless of signal type, the Smart Meter displays a large bargraph accurate to $\pm 3\%$ and visible from 10 meters away. The 4 ½ digit display shows the output in % of span or in engineering units (except with STT25H and STT25S HART). With the 4-20 mA signal, this digital display is accurate to $\pm 0.5\%$ of span. With the Digital DE signal, the display has no error; displaying the digital output exactly within its resolution of $\pm 0.05\%$ for a ± 199.9 reading range, $\pm 0.5\%$ for a ± 1999 reading range and $\pm 5\%$ for a ± 19990 reading range.

The Smart Meter includes various status message and engineering unit information on the LCD screen.

The Smart Meter obtains its power in series with the transmitter and requires 2.25 V power supply in addition to the transmitter's 10.8 V (i.e. 13.05 V minimum supply Volts). The minimum loop operating current is < 3.8 mA.

6.2 Connection Information

The addition of a meter changes the user wiring connections, because a serial connection of the meter in the negative 4-20 mA signal line from the transmitter is required. Wire the meter as shown in Figure 15.

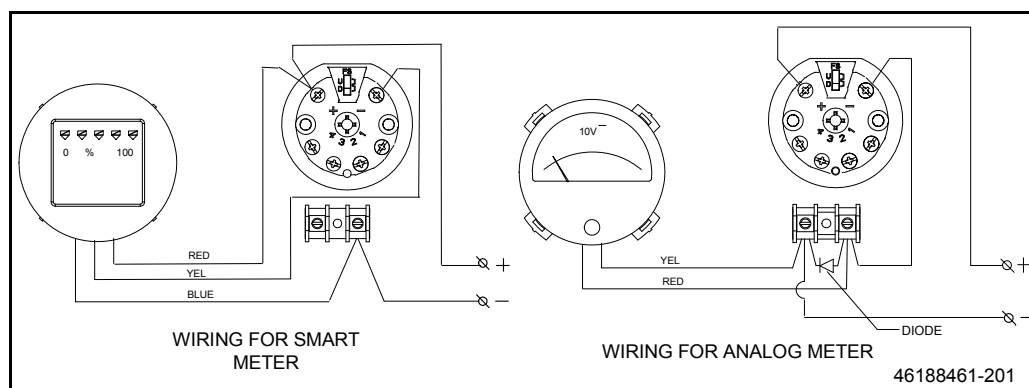

Figure 15: Meters Connections

6.3 Installation/Commissioning

After wiring the meter as shown in Figure 15 and powering up the transmitter loop, verify that the display operates as expected. The Smart Meter may require access to its configuration push button which is accessible via a hole on the side of the indication meter. This push button enables configuration of the preferred engineering unit and meter zero/span calibration for a 4-20 mA signal.

When the loop power is applied, the Smart Meter runs a self test diagnostic for about 10 seconds to determine correct loop operation and, if a digital DE signal is present, whether it is a 4 or 6 byte PV signal. Since most transmitters supplied with the Smart Meter operate in 6 byte digital DE output mode, this approach is covered first. If diagnostic displays are present on the meter (e.g. "**OUTPUT MODE**", "**BAD XMTR STATUS**" or "**FAULT-LAST KNOWN VALUE**") refer to Diagnostic and Troubleshooting (Section 6.4).

6.3.1 DE Transmitter (STT25D Model) Operating in 6 Byte Output Mode

Press button on the side of the meter to scroll through the display codes to the preferred engineering unit selection. The display codes are EU1, EU2, ..., EUF (and CAL).

For the STT25D:

- EU1 gives °C displayed on the LCD screen
- EU2 gives °F displayed on the LCD screen
- EU3 converts to °K (add on the stick-on label)
- EU4 converts to °R (add on the stick-on label)
- EU5 converts to mV (add on the stick-on label)
- EU6 converts to Volts (add on the stick-on label)
- EU7 converts to Ohms (add on the stick-on label)
- EU8 to EUF gives % (of span) displayed on the LCD screen.

Ignore "CAL" at this stage or refer to Section 6.4.3.

Press and hold the button until the desired display code appears. Release the button and the display reverts to the selected unit display. The Smart Meter is now configured for use. Replace the meter cap.

6.3.2 DE Transmitter (STT25D Model) Operating in 4 Byte Digital Output or in 4-20 mA Analog Mode

In these cases, the output signal does not include the transmitter database; only the % of span output signal. Part of this database, (e.g. LRV/URV), is required to enable an engineering unit display. Accordingly, press the "ID" key on the SFC. If the transmitter responds "**DE XMTR XXXXXXXX**" then also press the "**SHIFT**", "**ID**" keys. This enables the Smart Meter to recognize that the temperature units should be used and the necessary part of the database to convert to the preferred engineering units. Now configure the required engineering units as described in Section 6.3.1 above.

6.3.3 DE Transmitter (STT25D and STT25M Models) Operating in 4-20 mA Analog Output Mode

The Smart Meter is factory calibrated to convert the received 4-20 mA signal to a 0 to 100% of span display. Regardless of the transmitter's actual PV output, a display of 0.0% output means that the meter requires recalibration. Refer to Section 6.4 for the recalibration procedure.

6.4 Diagnostic and Troubleshooting

6.4.1 Analog Meter

The Analog Meter is an irreparable item. If it reads at the bottom of the scale with a known input, check that the connections are good and that the voltage across the meter/diode terminals is 0.5 to 0.7 V. This reading confirms that the delicate moving coil connections have been damaged and that the meter should be replaced.

6.4.2 Smart Meter

Every time power is cycled to the transmitter/meter combination, the Smart Meter runs a self test to check internal operations and switches on all display segments as shown in Figure 16 for up to 10 seconds. This enables confirmation of their operation.

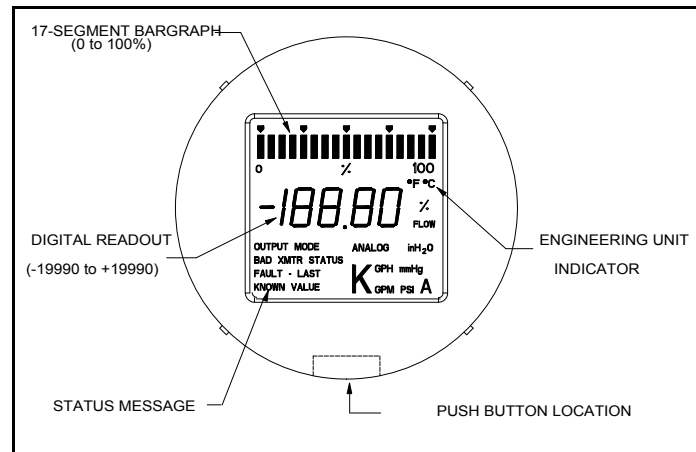

Figure 16: Horizontal Style Bargraph

6.4.2.1 Failed self test

If the self test fails, the display will go blank (i.e. revert to the unpowered display showing only the basic bargraph outline). Note that some of the temporarily switched on segments should only be seen with an STT250 in this initial self check e.g. "K" for a 1,000 engineering unit multiplier (only for readings over 20,000), "GPH", "GPM", "mmHg", "PSI", "%", "FLOW" and "inH₂O" (only used for flow and pressure transmitters).

ANALOG is switched on the LCD if the transmitter output signal is 4-20 mA analog.

The "Normal" display should have a partially switched on bargraph corresponding to the transmitter % of span output signal and the corresponding digital display in % of the selected units.

6.4.2.2 Meter Fault Conditions

The various possible fault conditions with corrective action are:

1. At power up, the LCD stays completely blank. Either the self check failed or the meter is not receiving power. Check the connections.
Note that the Smart Meter requires 2.25 Volts supply in addition to the minimum 10.8 Volts for the STT250 transmitter (i.e. minimum of 13.05 V across the meter/transmitter terminals). Verify adequate loop power is available.
2. At power up after showing all LCD segments, the display shows "**BAD XMTR STATUS**" and "___" instead of the digital engineering unit display. This means that the meter received a critical status diagnostic message from the transmitter at power up. Use the configuration tool to determine the critical status cause and correct.
3. After successful power up, the display shows "**BAD XMTR STATUS**" and the bargraph flashes. This means that a critical status condition occurred during operation. The display value may not be correct. Use the configuration tool to determine the cause and correct.
4. After successful power up, the display shows "**FAULT-LAST KNOWN VALUE**" and the bargraph flashes. This means that the on-going self diagnostics of the meter detected an internal fault or that communications from the transmitter were lost or that 5 or more corrupted messages were received from the transmitter operating in the digital output mode. Cycle the power to see if the condition self clears. If it recurs, check loop wiring for adequate loop power, ensure presence of the 250 ohm communications resistor and minimize electrical noise in the loop.
5. After successful power up, the display shows "**OUTPUT MODE**" and the bargraph flashes while the digital display flashes a value 0.0% to 100.0%. This means that the transmitter went to fixed output mode while operating as a digital output device. Connect the configuration tool and press "**OUTPUT**", "**CLEAR**" to revert to normal operation.
6. The display shows "**ANALOG**", "**0.0%**" and no bargraph segments switch on. This means that the Smart Meter requires calibration to the transmitter operating in 4-20 mA analog output mode. See Section 6.4.3.

6.4.3 4-20 mA Analog Mode Calibration of Smart Meter (DE Transmitter STT25D and STT25M Models only)

Calibration is beneficial to ensure display accuracy with a 4-20 mA analog signal. It is unnecessary to recalibrate the meter since all Smart Meters are factory calibrated before shipment. However, the facility is included in case recalibration for time drift or transmitter end point offsets are required.

Basically, accurate 4 and 20 mA signals are provided to the meter with the "**CAL**" configuration button selected. The 4 and 20 mA signals can be conveniently provided by using the configuration tool to switch the transmitter to "**OUTPUT MODE**".

The full calibration procedure for a Smart Meter is:

- **Step 1** - Put control loop to Manual and use the configuration tool to establish communications. Put the transmitter into 0% output mode by pressing "**OUTPUT**", "**0**", "**ENTER**" for "**0.0%**" on SFC.
- **Step 2** - Press and hold side button on meter. Release the button when "**CAL**" appears on the display. The meter will now carry out a zero (LRV) calibration and revert to normal operation. Press "**OUTPUT**", "**CLEAR**" to revert transmitter to continuous output operation.
- **Step 3** - Change output mode value to 100% by pressing "**OUTPUT**", "**1**", "**0**", "**0**", "**ENTER**".
- **Step 4** - Press and hold side button on meter. Release button when "**CAL**" appears on the display. The meter will now carry out a span (URV) calibration and revert to normal operation. Press "**OUTPUT**", "**CLEAR**" to revert transmitter to continuous output operation. Return loop to Automatic operation.

ATTENTION - If "**bAd**" appears on the meter display after Step 2 or 4 then the 4 mA or the 20 mA signal was not within the meter's acceptable accuracy range and calibration was aborted. Check the mA values and repeat calibration steps as required.

7. APPENDIX A

A.1 Overview

Honeywell's transient protectors external to housings (part number 30755970-501) are designed to protect STT 3000 transmitters from damaging transients induced by lightning or heavy electrical equipment.

Transient protectors divert induced surge current around the transmitter. This reduces the voltage potential between the housing and the internal electronic components from several thousand volts to a low and safe level.

A.2 Features and Benefits

The weatherproof transient protectors are sealed in epoxy in a ½ inch stainless steel pipe nipple. This is done to ensure that their performance is not affected by severe environmental conditions.

Other benefits of transient protectors are:

- Two stage protection,
- A common chamber, three-element, gas tube which assures ultra-fast and balanced clamping,
- A solid-state portion which holds the clamping voltage at a very low, safe level,
- Symmetric construction which assures equal performance in either polarity in surges or loop current.

A.3 Electrical Characteristics

Table A2 lists the electrical characteristics of transient protectors.

Table A2 Electrical Characteristics

Parameter		Specification
Compatibility		4-20 mA loops
Supply voltage		28 Vdc maximum
Resistance to loop added		44 ohms
DC clamping level	L-L (line to line)	36 V ± 10%
	L-G (line to ground)	200 to 350 V
Impulse clamping level	L-L	50V maximum
	L-G	800 to 1000 V
Surge	500A, 10 x 1,000 μs	400 Min.

A.4 Installation Procedure

The procedure in Table A3 outlines the steps for installing a transient protector external to an STT 3000 Series STT250 transmitter mounted inside a field mount housing with a 1/2"NPT conduit entry. For direct head mount housings, the ground terminal referred to in step 7 below may not exist and another means of direct ground connection will need to be devised. For proper protection, the green ground wire must be securely connected to a local ground in as direct a path as possible.

The transient protector is designed for conduit type wiring installations where an additional terminal box can be added to connect output wiring. In non-conduit installations, it is recommended that a suitable terminal box is also used.

Refer to Figure A17 for typical wiring connections.

Table A3 Transient Protector Installation

Step	Action
1	Unscrew housing cap.
2	Apply pipe joint tape or compound suitable for operating environment to threads on transient protector. Leave first two threads clean.
3	Hold transient protector so end with three wires points toward the right-hand conduit connection in transmitter's housing.
4	Feed three wires through conduit connection and screw protector into connection.
5	Connect red wire to positive (+) terminal of STT250 transmitter.
6	Connect black wire to negative (-) terminal of STT250 transmitter.
7	Connect green wire to ground terminal inside housing. ATTENTION: be sure to keep green wire short and straight.
8	Replace housing cap.
9	Connect the housing to a suitable earth ground using a #6 Nickel-clad copper wire.
10	Observing polarity, connect field wiring to two wires on other end of transient protector. Red wire is positive (+) and black wire is negative (-).

A.5 Wiring Reference

Figure A17 shows a typical wiring scheme of a transient protector to the STT 3000 Series STT250.

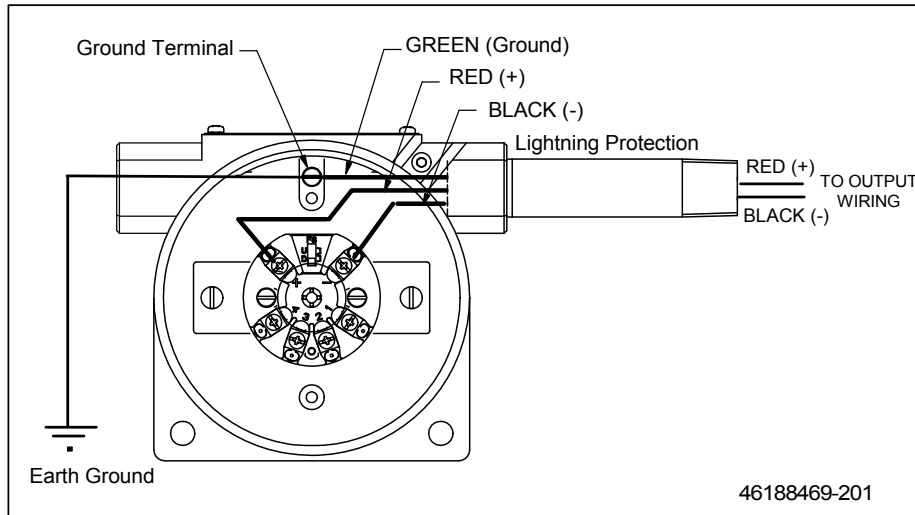
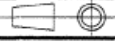
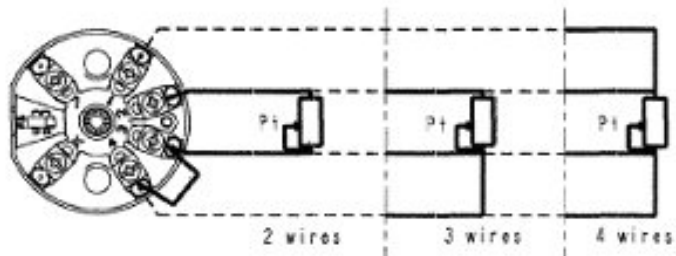
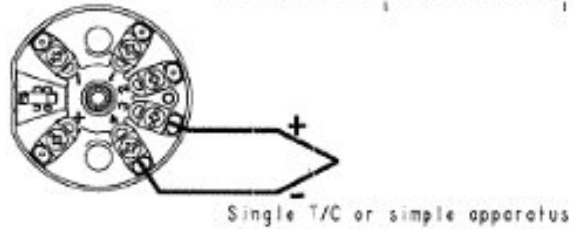
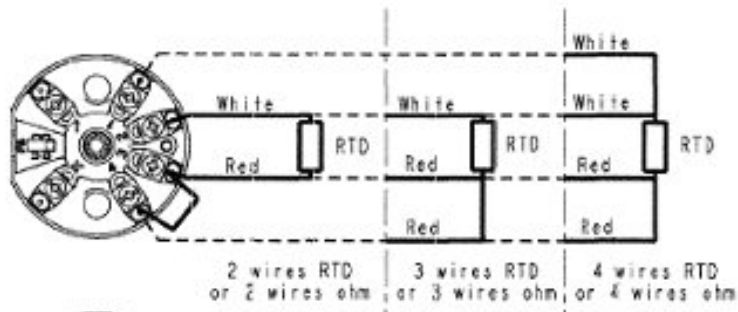

Figure A17: Typical wiring of transient protector to STT250 transmitter

A.6 FM Control Drawing 46188466-201

CERTIFICATION DOCUMENT ENGINEERING CHANGE ORDERS (ECO's) MUST BE AUTHORIZED BY APPROVALS ENGINEERING							
PRE-DESIGN RELEASE	DESIGN RELEASE	3	ECO-0030039	4/24/07		RJP	
30.01.98	06.02.98	2	Ajouté le cablage pour le dual sensors	18.11.00	3750-06T	R. DE	
		1	Création page 2/2 pour ajouter montage avec Surge protector	15.11.99	3750-062	R. DE	
TOLERANCES NON INSCRITES		ISSUE	MODIFICATIONS		DATE	E.C.N.	VISA
MATIERE :		 Honeywell				STT250	
FINITION OU TRAITEMENT		ECHELLE :	VISA	DATE	DESIGNATION : STT250 1/2		
CONTROLE DES PERFORMANCES		DESSINE PAR :	R. DE	30.01.98	Smart Temperature Transmitter Factory Mutual Intrinsically Safe Control Drawing		
ASSEMBLAGE SUIVANT :		VERIFIE PAR :	C. DA	03.02.98			
		ENGINEERING PROJ. MANAGER	M. KR	03.02.98			
		QUALITY ENGINEER	C. RO	03.02.98			
		MANUFACT. ORJAND PURCH. MANAGER	P. CR	03.02.98	46188466-201		



Input sensor wiring connections (Note 9 & 11)

TC/TC

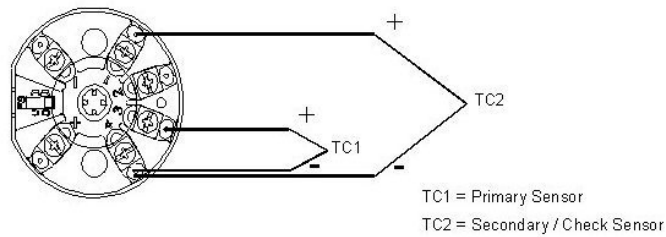

RTD/RTD

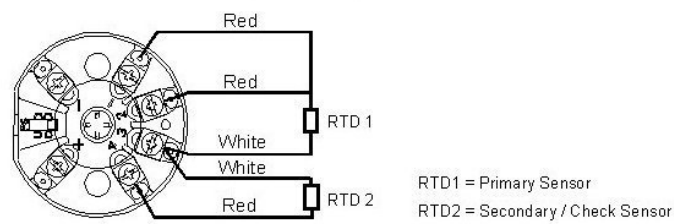

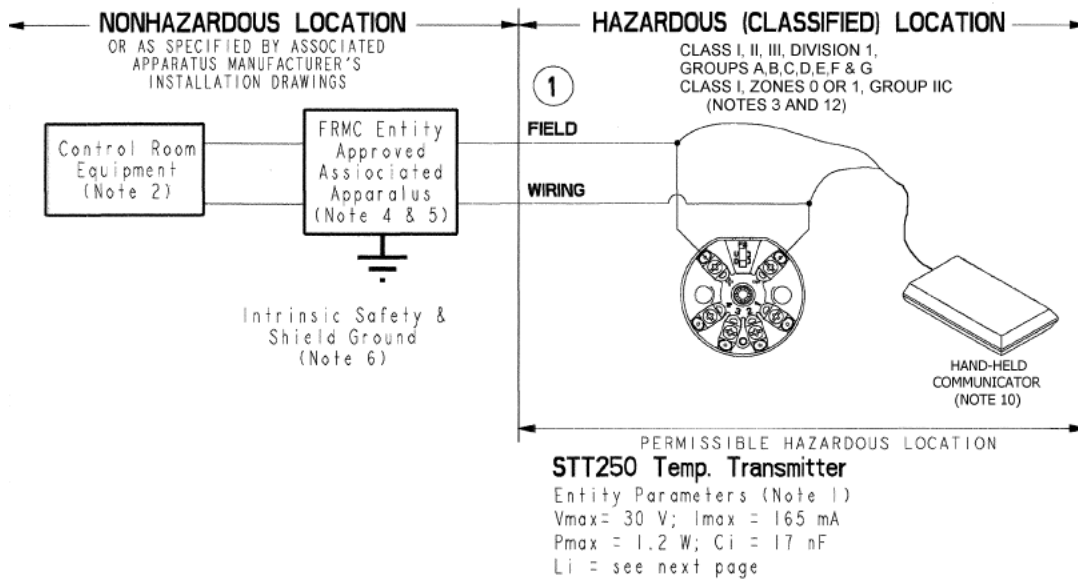

Notes:

- Select FMRC Entity Approved associated apparatus such that the following conditions exist:
 $V_{max} > V_{oc}$ OR V_t ; $I_{max} > I_{sc}$ OR I_t ; $(C_i \text{ of all loop devices} + C_{cable}) < C_a$;
 $(L_i \text{ of all loop devices} + L_{cable}) < L_a$
- Control equipment connected to associated apparatus must not use or generate more than 250V.
- For Class II & Class III installations where rigid conduit is not used, seal cable entries against dust and fibers using a NRTL listed cable gland fitting.
- Associated apparatus must be FMRC Approved. Associated apparatus may be installed within a Class I, Division 2, or Class I, Zone 2 Hazardous (classified) location if so Approved.
- Associated apparatus and hazardous location loop apparatus manufacturer's control drawings must be followed when installing a system.
- Non-galvanically isolated associated apparatus (zener barriers) must be connected to a suitable ground electrode per NFPA 70, Article 504. The resistance of the ground path must be less than 1 ohm.
- Installation must be in accordance with Article 500 of the NEC (ANSI/NFPA 70) and ANSI/ISA RPI2.6.
- No revision to this drawing is permitted without written FMRC Approval.
- Simple apparatus is a device that will neither generate nor store more than 1.2V, 0.1A, 25 mW or 20 μJ , such as switches, thermocouples, light-emitting diodes, connectors and RTD's.
- The Field Communicator shall be FMRC Approved for use in Class I, Division 1, Groups A, B, C, or D, or Class I, Zone 1, Group IIC hazardous locations only. The Field Communicator may be connected anywhere in the loop at which connections are accessible. See the Field Communicator installation manual for further details.
- The following cable parameters for the input connections must not be exceeded:

Group	Capacitance (μF)	Inductance (mH)
A, B	2.0	22
C, E	7.0	85
D, F, G	20	183
- The STT250 electronics assembly (module only) is FMRC Approved for use only within a Class I, Division 1, Groups A, B, C, or D, or Class I, Zone 1, Group IIC hazardous location
- The STT250 Temp Transmitter is also nonincendive for use in Class I, Division 2, or Class I, Zone 2 (module only) and Class II and III, Division 2, Groups F and G (with field mounted housing). Connection to intrinsic safety barriers is not required. Supply voltage not to exceed 35 Vdc.

**ASSEMBLIES WITH
SURGE PROTECTOR
46188660-XXX**

WITHOUT METER

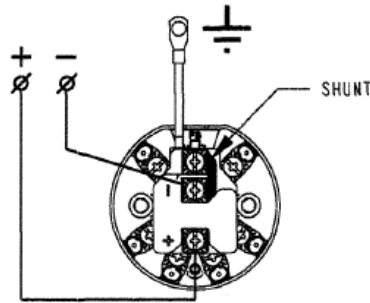

$L_i = 45 \mu\text{H}$

OPTIONAL INTEGRAL ANALOG METER

4 - 20 mA LOOP CONNECTION

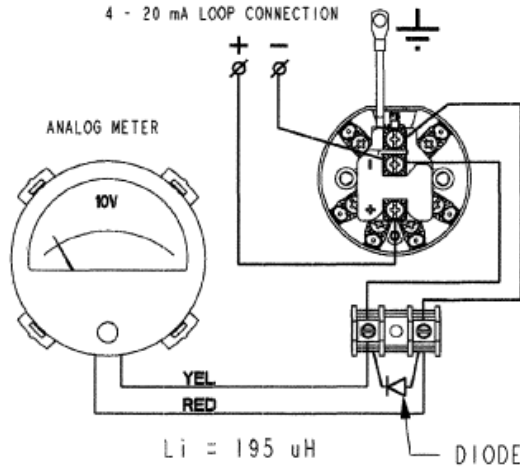

$L_i = 195 \mu\text{H}$

OPTIONAL SMART METER

DIGITAL DE OUTPUT CONNECTION

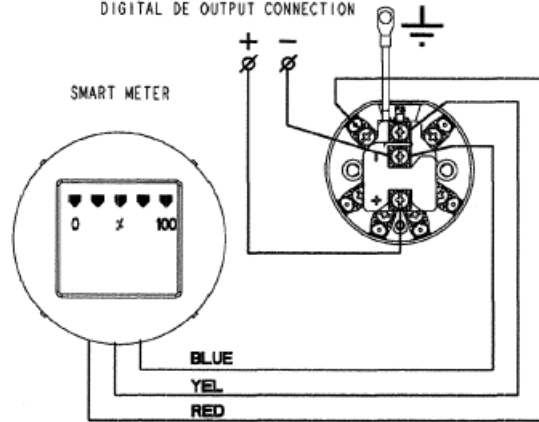

$L_i = 45 \mu\text{H}$

ASSEMBLIES WITHOUT SURGE PROTECTOR

WITHOUT METER

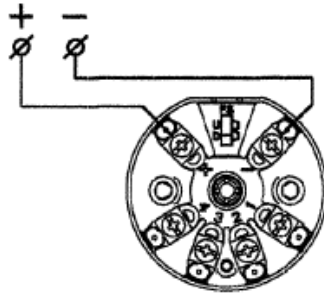

$L_i = 0$

OPTIONAL INTEGRAL ANALOG METER

4 - 20 mA LOOP CONNECTION

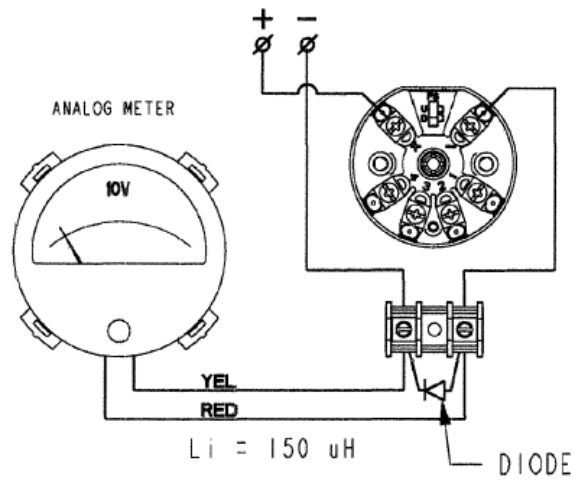

OPTIONAL SMART METER

DIGITAL DE OUTPUT CONNECTION

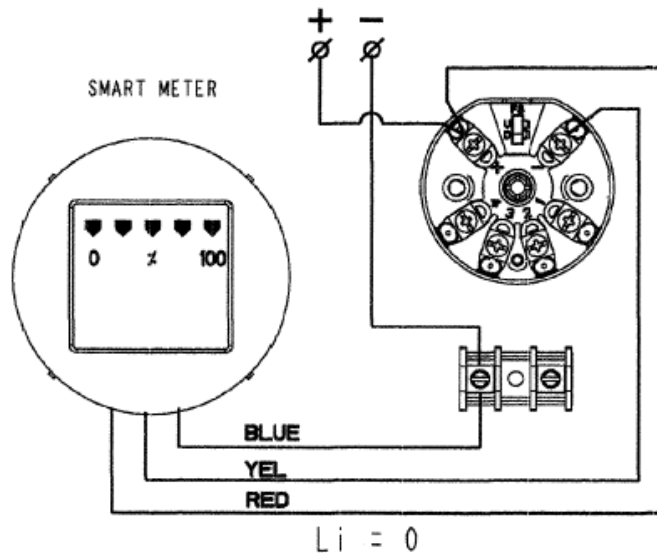

ASSEMBLIES WITH SURGE PROTECTOR 46188660-XXX

OPTIONAL EU METER

DIGITAL DE OUTPUT CONNECTION

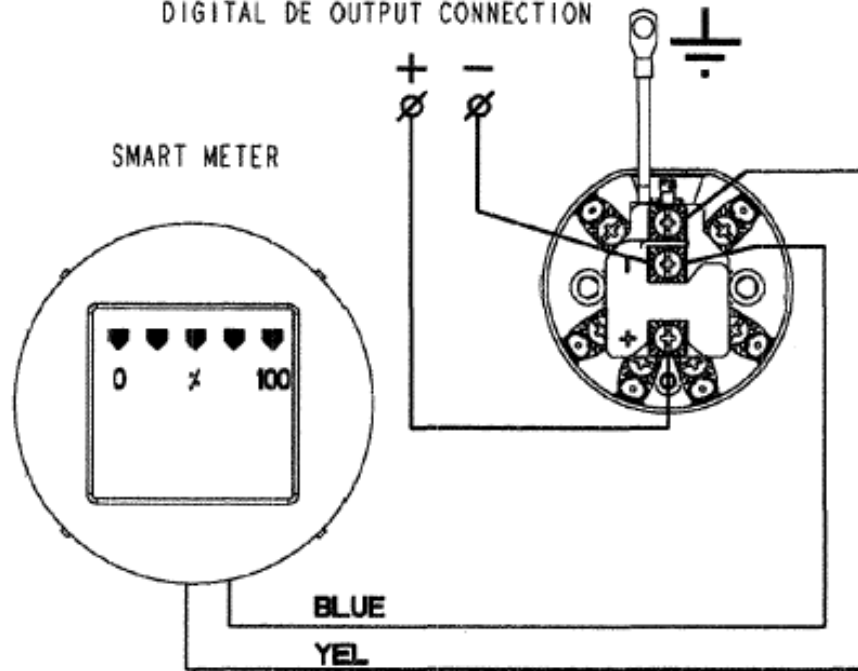

$$L_i = 45 \mu H$$

ASSEMBLIES WITHOUT SURGE PROTECTOR

OPTIONAL EU METER

DIGITAL DE OUTPUT CONNECTION

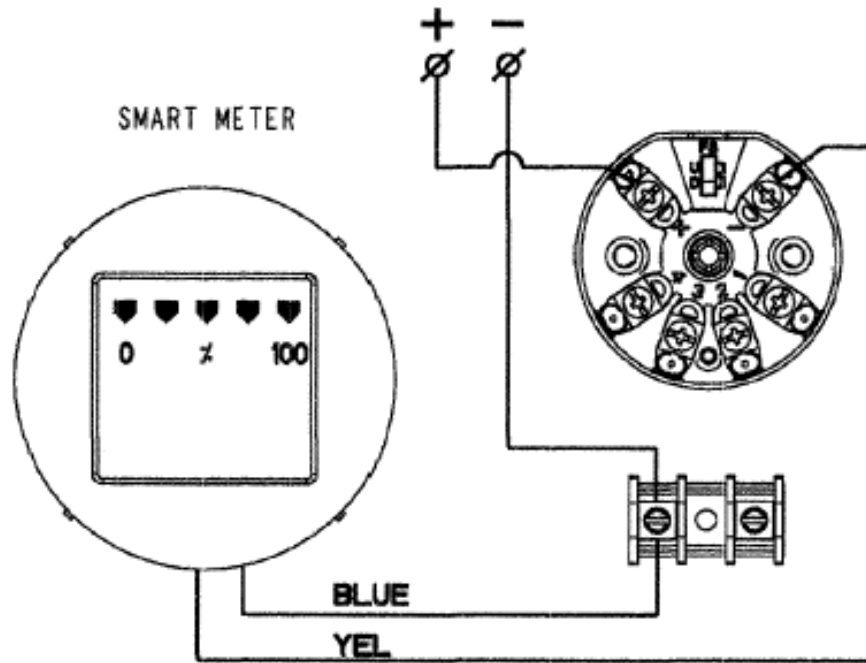

Li = 0

	Honeywell	STT250
DESIGNATION :	STT250	2/2
Smart Temperature Transmitter		
Factory Mutual		
Intrinsically Safe Control Drawing		
46188466-201		

A.7 CSA Control Drawing 46188466-202

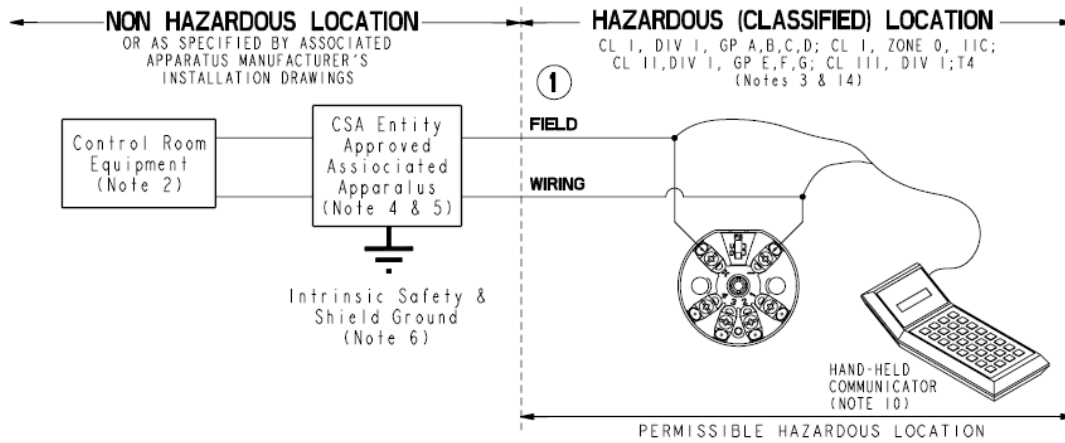

STT250 Temp. Transmitter
 Entity Parameters (Note 1)
 $V_{max} = 30\text{ V}$; $I_{max} = 165\text{ mA}$
 $P_{max} = 1.2\text{ W}$; $C_i = 17\text{ nF}$
 $L_i = \text{see next page}$

Notes:

- Select CSA Approved associated apparatus such that the following conditions exist:
 $V_{max} > V_{oc}\text{ OR }V_t$; $I_{max} > I_{sc}\text{ OR }I_t$; $(C_i\text{ of all loop devices} + C_{cable}) < C_a$;
 $(L_i\text{ of all loop devices} + L_{cable}) < L_a$
- Control equipment connected to associated apparatus must not use or generate more than 250V.
- For Class II & Class III installations where rigid conduit is not used, seal cable entries against dust and fibers using a NRTL listed cable gland fitting.
- Associated apparatus must be CSA Approved. Associated apparatus may be installed within a Class I, Division 2, or Class I, Zone 2 Hazardous (classified) location if so Approved.
- Associated apparatus and hazardous location loop apparatus manufacturer's control drawings must be followed when installing a system.
- Non-galvanically isolated associated apparatus (zener barriers) must be connected to a suitable ground electrode per NFPA 70, Article 504. The resistance of the ground path must be less than 1 ohm.
- Installation must be in accordance with section 18 of the Canadian Electrical Code and ANSI/ISA RPI2.6.
- No revision to this drawing is permitted without written CSA Approval.
- Simple apparatus is a device that will neither generate nor store more than 1.2V, 0.1A, 25 mW or 20 μJ , such as switches, thermocouples, light-emitting diodes, connectors and RTD's.
- The Field Communicator shall be CSA Approved for use in Class I, Division 1, Groups A, B, C or D, or class I, zone 0, Group IIC hazardous locations only. The Field Communicator may be connected anywhere in the loop at which connections are accessible, see the Field Communicator installation manual for further details.
- The following cable parameters for the input connections must not be exceeded:

Group	Capacitance (μF)	Inductance (mH)
A, B	2.0	22
C, E	7.0	85
D, F, G	20	183
- The STT250 electronics assembly (module only) is CSA Approved for use only within a Class I, Division 1, Group A, B, C, or D or Class I, Zone 0, Group IIC hazardous location
- The STT250 Temp Transmitter is also nonincendive for use in Class I, Div. 2, or Class I, Zone 2 (module only) and Class II and III, Division 2, Groups F and G (with field mounted housing). Connection to intrinsic safety barriers is not required. Supply voltage not to exceed 35 Vdc.
- WARNING- Substitution of components may impair intrinsic safety.

CERTIFICATION DOCUMENT
 ENGINEERING CHANGE
 ORDERS (ECO'S) MUST BE
 AUTHORIZED BY APPROVALS
 ENGINEERING

2

UNPUBLISHED, HONEYWELL CONFIDENTIAL, TRADE SECRET. IN THE EVENT OF PUBLICATION THE FOLLOWING NOTICE SHALL APPLY: COPYRIGHT 2001, HONEYWELL INTERNATIONAL, INC. ALL RIGHTS RESERVED. THIS DOCUMENT IS PROPRIETARY INFORMATION OF HONEYWELL INTERNATIONAL, INC. NEITHER THIS DOCUMENT NOR THE INFORMATION CONTAINED HEREIN SHALL BE REPRODUCED, USED OR DISCLOSED TO OTHERS WITHOUT THE WRITTEN AUTHORIZATION OF HONEYWELL. USE, DUPLICATION, OR DISCLOSURE OF THIS DOCUMENT IS SUBJECT TO THE RESTRICTIONS SET FORTH IN A WRITTEN AGREEMENT. NOTHING CONTAINED HEREIN SHALL BE CONSTRUED AS CONFESSING BY IMPLICATION, ESTOPPEL, OR OTHERWISE ANY LICENSE TO ANY PATENT, TRADEMARK, COPYRIGHT OR OTHER INTELLECTUAL PROPERTY RIGHT OF HONEYWELL OR ANY THIRD PARTY.	PROJECTION	DRAWN R. DE 30.01.98		
	LINEAR MEASURE mm IN	CHECKED		DEV ENGR
	MATERIAL	MFG ENGR		QA ENGR
	FINISH	MAT ENGR		TOLERANCE UNLESS NOTED
	ANGULAR DIMENSION	SCALE: NONE USED ---	SHT 1 OF 2	
		C/A2	46188466-202	

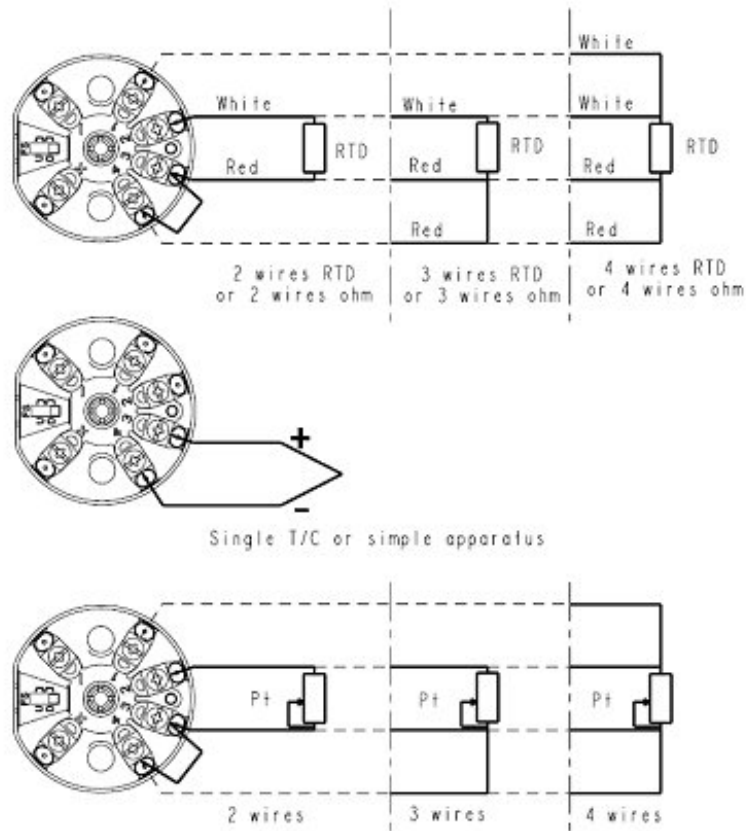

Input sensor wiring connections (Note 9 & 11)

TC/TC

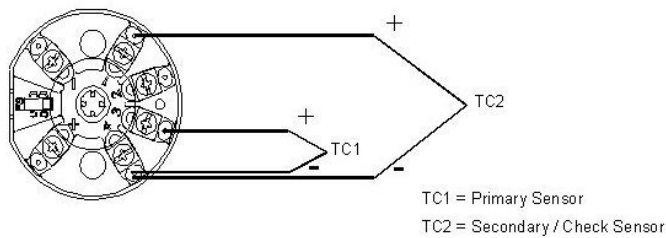

RTD/RTD

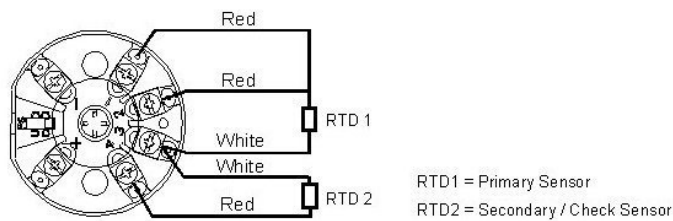

**ASSEMBLIES WITH
SURGE PROTECTOR
46188660-XXX
WITHOUT METER**

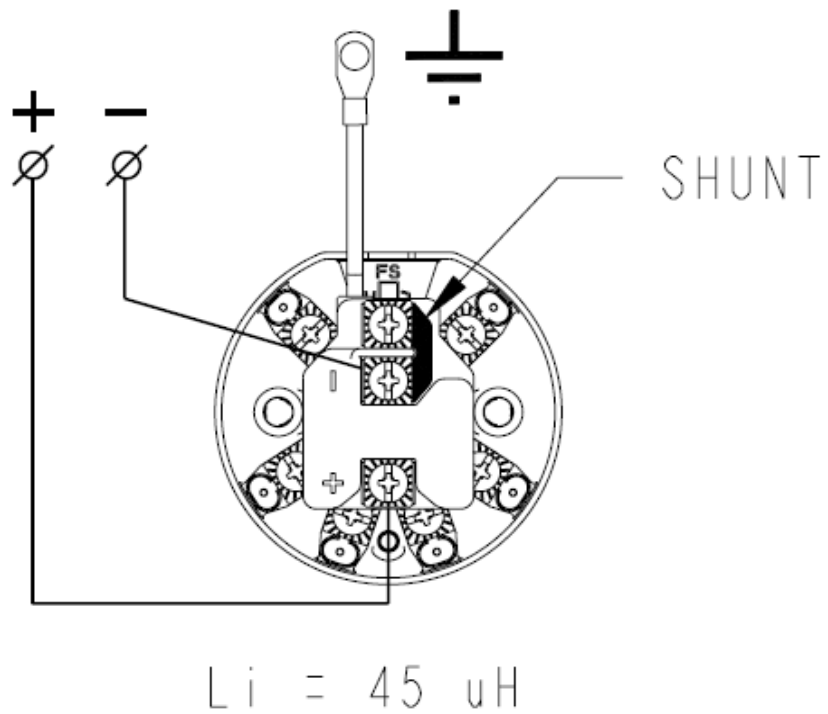

OPTIONAL INTEGRAL ANALOG METER

4 - 20 mA LOOP CONNECTION

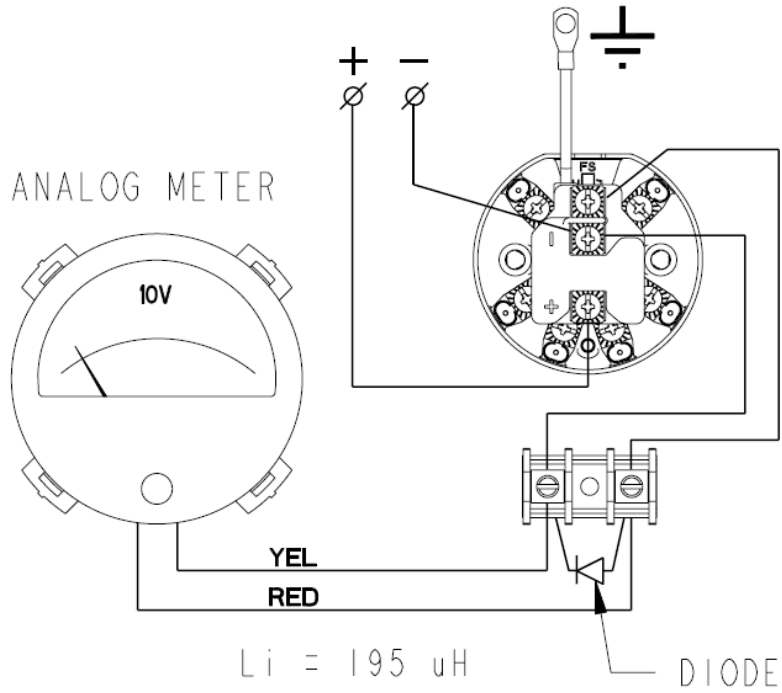

OPTIONAL SMART METER

DIGITAL DE OUTPUT CONNECTION

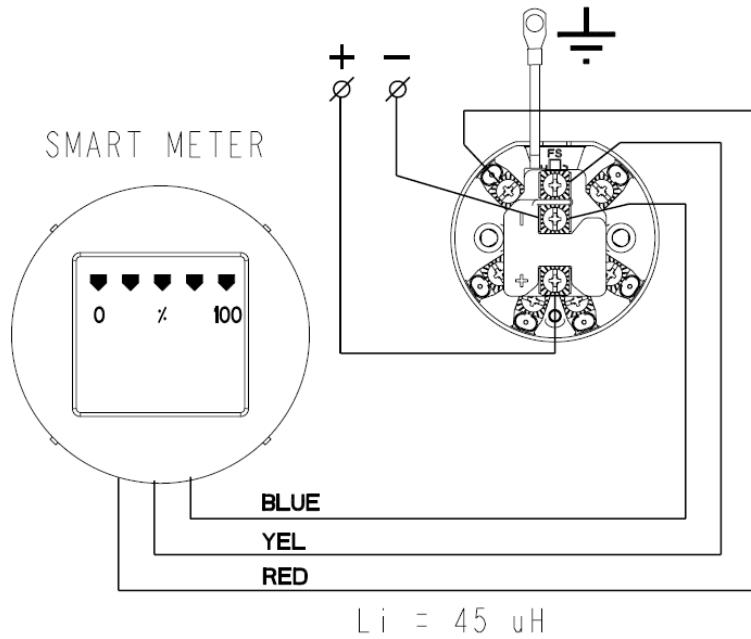

ASSEMBLIES WITHOUT SURGE PROTECTOR WITHOUT METER

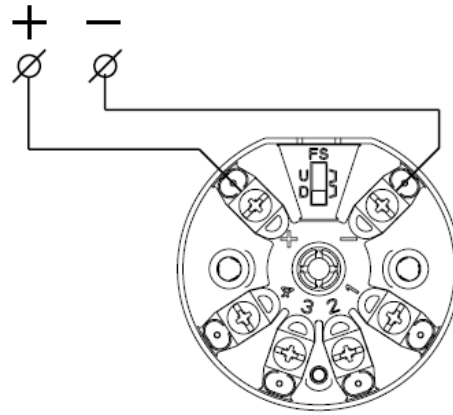

$L_i = 0$

OPTIONAL INTEGRAL ANALOG METER

4 - 20 mA LOOP CONNECTION

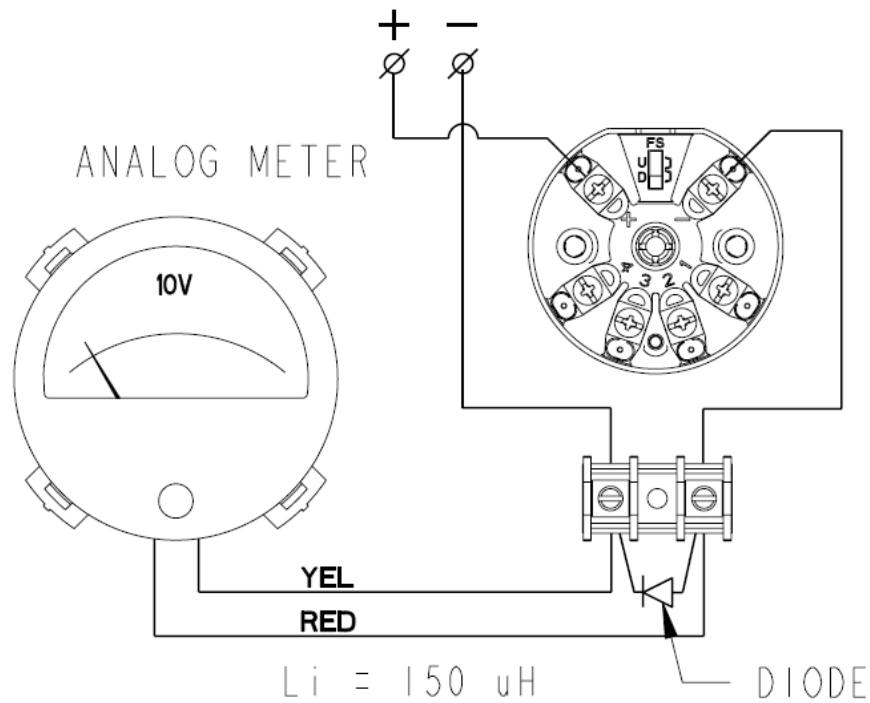

OPTIONAL SMART METER

DIGITAL DE OUTPUT CONNECTION

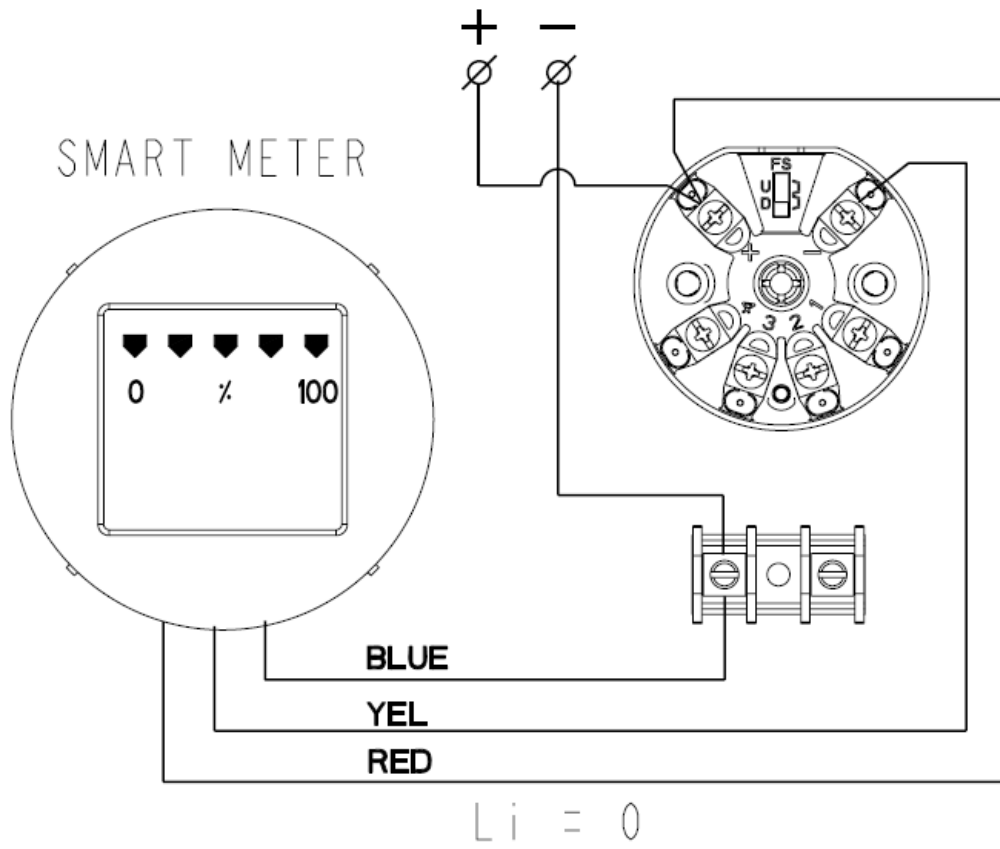

ASSEMBLIES WITH SURGE PROTECTOR 46188660-XXX

OPTIONAL EU METER
DIGITAL DE OUTPUT CONNECTION

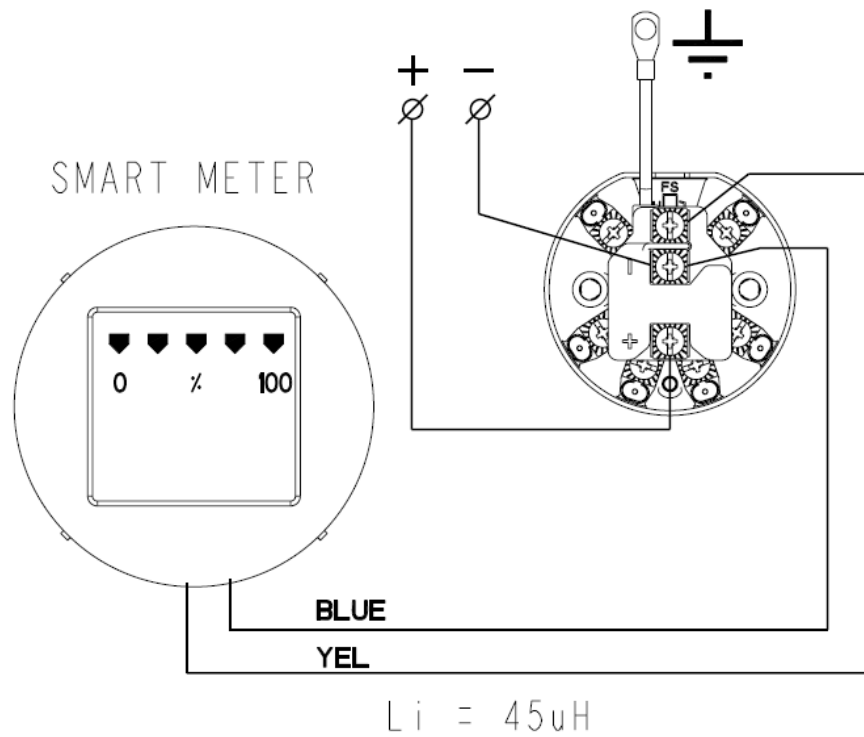

ASSEMBLIES WITHOUT SURGE PROTECTOR OPTIONAL EU METER

DIGITAL DE OUTPUT CONNECTION

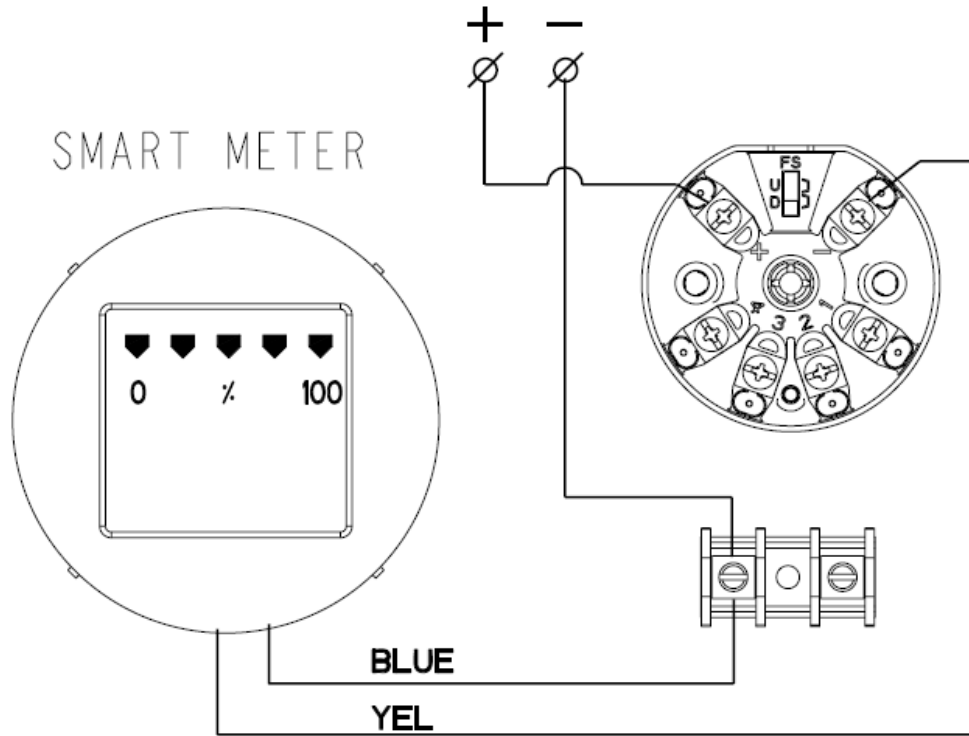

$L_i = 0$

Honeywell	$\frac{C}{A2}$	46188466-202		
	SCALE: NONE	REV: 3	DATE: 290507	SHEET: 2 OF 2

**STT 3000 – Series STT250 Smart
Temperature Transmitter,
Models STT25H,STT25S, STT25D,
STT25M, STT25T**

**EN11-6190-A3
9/07**

**Addendum
(to Operator Manual
EN11-6190)**

Overview

ATEX Directive 94/9/EC

The ATEX Directive 94/9/EC is a European CE Mark directive concerning products that are designed for use in potentially explosive environments. This “New Approach” directive is based on, and is an expansion of, European Norms (EN, CENELEC standards).

On June 30, 2003, the ATEX (ATmospheres EXplosibles) directive will replace directives currently in effect, and from that time, only products with the ATEX certification and with ATEX labeling will be approved for free movement in the EU (European Union) and EFTA (European Free Trade Association) countries. As defined in the directive, “free movement” refers to:

- placing a product on the market, and/or
- placing a product into service.

The ATEX Directive 94/9/EC is a living (set of) document(s), subject to further change and refinement, whose details are beyond the scope of this addendum. Further information can be obtained in the Official Journal of the European Communities No L100/1, and in related publications such as Guidelines on the Application of Directive 94/9/EC. Both of these items are available at:

<http://europa.eu.int/comm/enterprise/atex/index.htm>

Products that have been previously certified under the EN and CENELEC European Norms, and which comply fully with all standards in the New Approach directive have, by application, received certification under ATEX Directive 94/9/EC.

The Honeywell STT 3000 Series STT250 Smart Temperature Transmitter is now ATEX certified, and all units manufactured currently and in the future will include labeling that includes all markings required under the ATEX directive.

Inclusions

To ensure that all required information will be available to the user, the following items are included with this Addendum for reference:

1. Declaration of Conformity – ATEX CE0344 (Honeywell document number 51453718 Revision A).
2. Certificate of Manufacturer II 3 G EEx nA ATEX CE (Honeywell document number 51453719 Revision A).

**Purpose and
Content of
this
Addendum**

This Addendum includes information required under the ATEX Directive regarding:

1. The appearance and meaning of each certification mark (CE Mark) that appears on the label(s) affixed to the product.
2. Instructions for installation and use of the product.

Information required for installation and use of this product is given in

EN11-6190 STT 3000 – Series 250 Smart Transmitter Models STT25M, STT25H, STT25S, STT25D, STT25T Operator Manual

of which this Addendum is a part.

Details regarding certification marks that appear in labeling for this product are given in this addendum.

Attention

The publication cited above and the functioning and construction (except for labeling) of the devices described therein are essentially unchanged. The purpose of this addendum is to provide details on the purpose and appearance of the labels attached to each device under ATEX Directive 94/9/EC.

Attention

Before installing the equipment in a potentially explosive atmosphere, please read the information provided in this Addendum, which supports the ATEX certifications for this product.

CE Conformity

The STT 3000 Smart Temperature Transmitter, Models STT250, are in conformity with the protection requirements of the following European Council Directives: 94/9/EC, the Explosive Atmospheres (ATEX) Directive, and 2004/108/EC, the Electromagnetic Compatibility (EMC) Directive.

In conformity with the ATEX directive, the CE mark on the certification nameplate includes the Notified Body identification number 0344 (KEMA 01ATEXQ3199) adjacent to the EC Type Examination Certificate number.

Deviation from the installation conditions in this manual may invalidate this product's conformity with the Explosive Atmospheres, Pressure Equipment, and EMC Directives.

Conformity of this product with any other "CE Mark" Directive(s) shall not be assumed.

Equipment and systems covered by this certificate are as follows:
 Temperature is measured with an external sensor (thermocouple or resistor (RTD) sensor).
 The output from the transmitter is a 4-20 mA signal via the two-wire field connections. Letter designations in the model number specify the communications protocol:

Device Name	Transmitter Output
STT25M	4-20 mA
STT25H (HART5)	HART-5 protocol and 4-20 mA
STT25H (HART6)	HART-6 protocol and 4-20 mA
STT25S	HART-6 protocol and 4-20 mA
STT25D	Digital DE / 4-20 mA
STT25T (HART5)	Dual Input, HART-5 / 4-20 mA
STT25T (HART6)	Dual Input, HART-6 / 4-20 mA

The process variable can be observed locally when the ME, SM or EU indicators (when compatible with the communications protocol) installed in the metal enclosure.

**Marking,
ATEX Directive**

Honeywell's Model STT 3000 Smart Temperature Transmitter, with the following nameplates attached, has been certified to comply with Directive 94/9/EC of the European Parliament and the Council as published in the Official Journal of the European Communities No. L 100/1 on 19-April-1994.

The following information is provided as part of the labeling of the transmitter:

- Name and Address of the manufacturer: Honeywell, Automation India Ltd. 56 & 57 Hadapsar Industrial Estate, Pune 411013, India.
- Notified Body identification: KEMA Quality B.V., Arnhem, the Netherlands



- For complete model number, see the Model Selection Guide 34-44-16-03 for the particular model of temperature transmitter.
- The serial number of the transmitter is located on the module label. For models STT25M and STT25D the serial number is 10 characters (0 through 9) long. The last two characters are fixed 37. The first character (0) is a B. Characters 2 and 3 are the week of manufacture and the single character 4 is the year of manufacture. The serial number consists of characters 1, 5, 6, and 7.
- For models STT25H, STT25S and STT25T the new serial number has characters 0 through 3 as the serial number, characters 4 and 5 are the week of manufacture and characters 6 and 7 are the year of manufacture.

**Apparatus
Marked with
Multiple Types of
Protection**

The user must determine the type of protection required for installation the equipment. The user shall then check the box [✓] adjacent to the type of protection used on the equipment certification nameplate. Once a type of protection has been checked on the nameplate, the equipment shall not then be reinstalled using any of the other certification types.

Label 50019638-001, ia, 4-20 mA / DE, is mounted on the module. The following is a representation of this label:

Honeywell			LCIE 06 ATEX 6066 X, Ex ia IIC; T6 (Ta = -50°C TO +40°C) T5 (Ta = -50°C TO +55°C), T4 (Ta = -50°C TO +85°C) Ui = 30V, Ii = 165 mA, Pi = 1.2W INSTALL PER EN11-6190	II 1 G
STT 3000 SMART TEMP. TRANSMITTER SUPPLY: 11 - 35 VDC, OUTPUT: 4 - 20 mA AMBIENT LIMITS: -40°C TO +85°C MODEL:	SN: _____ TAG: _____ CAL: _____ 50019638-001 ISS. B ASSEMBLED IN INDIA - PUNE, 411013 INDIA		 0344	

Label 50019639-001, ia, 4-20 mA / DE, is mounted on the module. The following is a representation of this label:

Honeywell			Ex nA IIC T6 (Ta = -50°C TO +85°C) ZONE 2, SUPPLY = 30V, 23mA INSTALL PER EN11-6190 IN AN ENCLOSURE RATED IP 54 MINIMUM	II 3 G
STT 3000 SMART TEMP. TRANSMITTER SUPPLY: 11 - 35 VDC, OUTPUT: 4 - 20 mA AMBIENT LIMITS: -40°C TO +85°C MODEL:	SN: _____ TAG: _____ CAL: _____ 50019639-001 ISS. B ASSEMBLED IN INDIA - PUNE, 411013 INDIA			

Nameplate 50019640-001, (ia) 4-20 mA / DE / HART, nameplate. The following is a representation of this nameplate:

Honeywell		STT 3000 SMART TEMPERATURE TRANSMITTER	
MODEL: _____			
CUST. ID: _____ MFG DATE: _____	LCIE 06 ATEX 6066 X, Ex ia IIC; AMBIENT LIMITS -50°C TO +85°C T6 (Ta = -50°C TO +40°C), T5 (Ta = -50°C TO +55°C), T4 (Ta = -50°C TO +85°C) Ui ≤ 30V, Ii ≤ 165 mA, Pi ≤ 1.2W ENCLOSURE IP 66/67 - INSTALL PER EN11-6190		II 1 G
50019640-001 ISS. B ASSEMBLED IN INDIA - PUNE, 411013 INDIA		 0344	

Nameplate 50019641-001, (d) 4-20 mA / DE / HART, nameplate. The following is a representation of this nameplate:

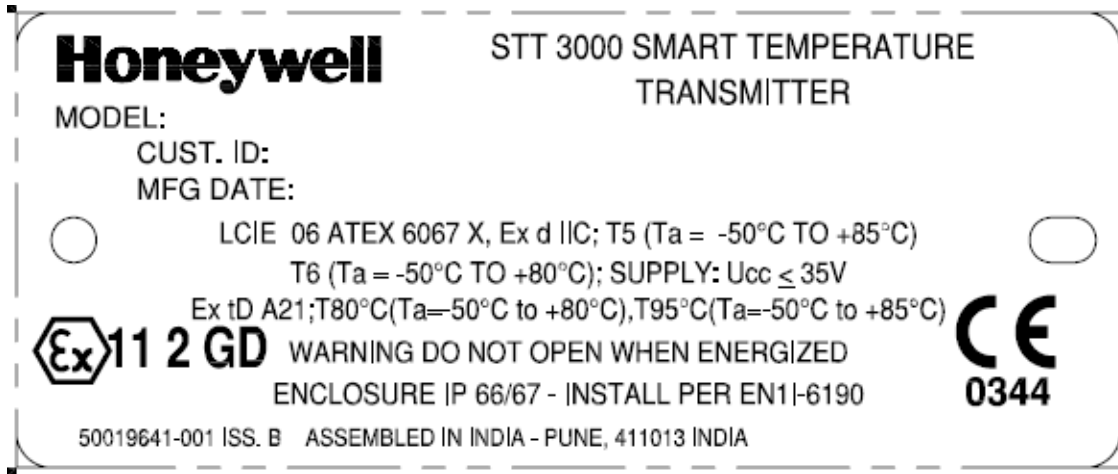

Nameplate 50019642-001, (d) 4-20 mA / DE / HART, nameplate. The following is a representation of this nameplate:

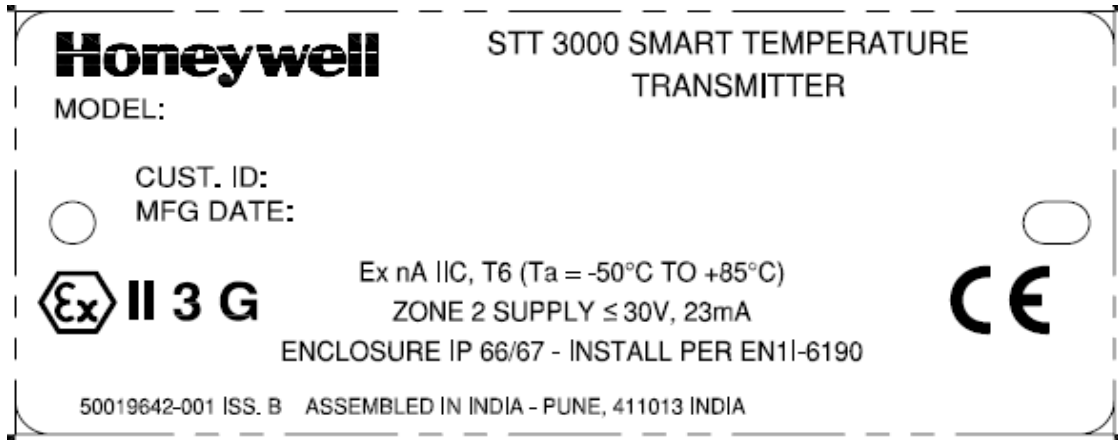

Nameplate 50019643-001, 4-20 mA / DE / HART, multiple certification nameplate. The following is a representation of this nameplate:

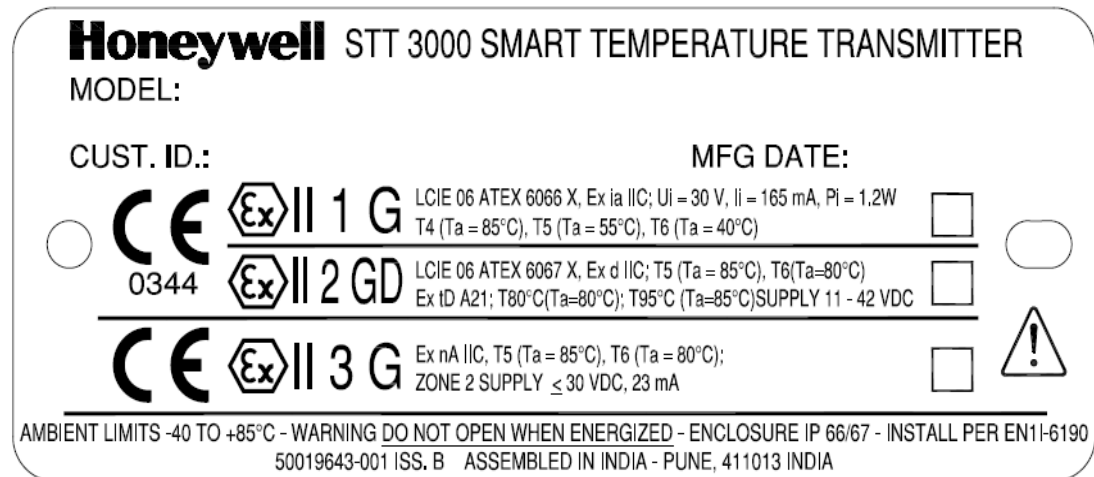

Identification of Entries

Cap- M105x2;

Cable entry- 1/2"NPT (Z) and M20x1.5

Adaptor- 1/2" NPT to M20x1.5 and 1/2 "NPT to 3/4" NPT

Specific Parameters for Intrinsic Safety

Field wiring terminals, (+, -):	$U_i \leq 30 \text{ V}$,	$I_i \leq 165 \text{ mA}$, $P_i \leq 1.2 \text{ W}$
Without local analog meter, ME:	$C_i \leq 17 \text{ nF}$,	$L_i \leq 45 \mu\text{H}$
With local analog meter, ME:	$C_i \leq 17 \text{ nF}$,	$L_i \leq 195 \mu\text{H}$
With local smart digital meter, SM:	$C_i \leq 17 \text{ nF}$,	$L_i \leq 45 \mu\text{H}$
With local EU meter,EU:	$C_i \leq 17 \text{ nF}$,	$L_i \leq 45 \mu\text{H}$
Sensor entry terminals (1, 2, 3, & 4)	$U_o \leq 10.5 \text{ V}$	$I_o \leq 40 \text{ mA}$
	$C_o \leq 2.08 \mu\text{F}$	$L_o \leq 20\text{mH}$

Special conditions for safe use,

The Smart Temperature Transmitter is an intrinsically safe apparatus that can be installed in potentially explosive atmospheres.

The supply terminals (+, -) must be connected only to a certified associated intrinsically safe apparatus.

Intrinsic Safety (X)

The sensor entry terminals (1, 2, 3, and 4) must be connected only to certified intrinsically safe equipment or according to paragraph 1.3 of standard EN 50014.

The electrical parameters (U, I, and P) of the associated apparatus connected to the power terminals (+, -) must not exceed the following values:

$U_i \leq 30\text{V}$ $I_i \leq 165 \text{ mA}$ $P_i \leq 1,2 \text{ W}$

The electrical parameters (L and C) of the apparatus connected to the sensor entry terminals (1, 2, 3, and 4) (cabling parameters included) must not exceed the following values:

$C_{ext} = 2 \mu\text{H}$ $L_{ext} = 2 \text{ mH}$

Certification ambient operating temperature : -50°C to 85°C

Standard specification ambient limits : -40°C to 85°C .

Temperature classifications:

<u>IS (ia) 4 – 20 mA / DE</u>	<u>Flameproof (d)</u>
T6 up to $T_a \leq 40^\circ\text{C}$	T6 up to $T_a \leq 80^\circ\text{C}$
T5 up to $T_a \leq 55^\circ\text{C}$	T5 up to $T_a \leq 85^\circ\text{C}$
T4 up to $T_a \leq 90^\circ\text{C}$	

Enclosure classification: IP 66/67, Type 4X

Special conditions for safe use, Flameproof Installation

Ambient operating temperature: -50 to 85°C

Specific Parameters for Non-Sparking Zone 2 Installation

(Honeywell certified)

Supply Voltage: 11-30 Vdc

Supply Current: 23 mA

Ambient Temperature Limits: -50°C to 85°C

Temperature Classification: T6 at $T_a \leq 80^\circ\text{C}$

T5 at $T_a \leq 85^\circ\text{C}$

Special Conditions for Safe Use, Non-Sparking Zone 2 Installation

(Honeywell certified)

The installation of this equipment in Zone 2 hazardous areas must comply with VDE specification 0165, EN 60079-14, EN 60079-15 and/or valid national standards for installation and operation.

Before commissioning of this equipment, it must be verified that the power supply voltage cannot exceed the 35 Vdc maximum for 4-20 mA analog, DE, and HART equipment.

The electronic assemblies in these units are non-repairable items, and if faulty, must be replaced. The electrical power supply must be switched off before any replacement and during any time that the wiring terminations are being connected or disconnected.

**ATEX****0344**

We declare under our sole responsibility that the following products,

**STT 3000 – Series STT250 Smart Temperature Transmitter,
Models STT25M, STT25H, STT25S, STT25D, STT25T**

to which this declaration relates, are in conformity with the protection requirements of Council Directive: 94/9/EC (ATEX Directive) on the approximation of the laws of the Member States concerning equipment and protective systems intended for use in potentially explosive atmospheres, and 89/336/EEC (EMC Directive) as amended by 92/31/EEC, 93/68/EEC and 2004/108/EC on the approximation of the laws of the Member States relating to Electromagnetic Compatibility.

The models covered by this Declaration and evidence of conformity with the ATEX Directive are listed below. Conformity to the ATEX Directive is in accordance with the following European standards.

EN 60079-0-2004 Electrical Apparatus for Potentially Explosive Atmospheres - General Requirements

EN 61241-0-2004 Electrical Apparatus for use in presence of combustible dust- Part 0-General Requirements

EN 60079-1-2004 Electrical Apparatus for Potentially Explosive Atmospheres - Flameproof Enclosure "d"

EN 61241-1-2004 Electrical Apparatus for use in presence of combustible dust- Part 1-Protection by enclosures "tD"

EN 60079-11-2007 Electrical Apparatus for Potentially Explosive Atmospheres - Part 11-Intrinsic Safety "i"

EN 60079-26-2004 Special Requirements for Construction, Test and Marking of Electrical Apparatus of Equipment Group II, Category 1 G

EN 61010-1-2001 Safety Requirements for Electrical Equipment for Measurement, Control & Laboratory Use, Part 1: General Requirements

EN 61326-1997+A1+A2 Electrical Equipment for Measurement, Control and Laboratory Use – EMC Requirements

Notified Bodies:

EC Type Examination Certificates

LCIE – Groupe Bureau Veritas – 0081
33, Avenue du Général Leclerc,
92260 Fontenay-aux-Roses, France

Production Quality Assurance Notification

KEMA Quality B. V. – 0344
Utrechtseweg 310
6812 AR Arnhem, The Netherlands

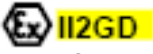
Certificate	Protection	Configuration	Description
LCIE 06 ATEX 6066X	 Ex ia IIC, T6 to T4	Module only 'ia'	Models STT25M, 4-20 mA, STT25H, 4-20 mA/HART5, STT25H, 4-20 mA/HART6, STT25D, 4-20 mA/DE, and STT25T, Dual Input, and 4-20 mA/HART
LCIE 06 ATEX 6067X	 Ex d IIC, T6 or T5 Ex tD A21 T80°C or T95°C	Module mounted in 'd' enclosure only	Models STT25M, 4-20 mA, STT25H, 4-20 mA/HART5, STT25S, 4-20 mA/HART6, STT25D, 4-20 mA/DE, and STT25T, Dual Input, and 4-20 mA/HART

Manufacturing Locations: **Honeywell Automation India Ltd.**
56 & 57 Hadapsar Industrial Estate ,Pune,411013 India

The authorized signatory to this declaration, on behalf of the manufacturer, and the Responsible Person is identified below.

Honeywell Automation India Ltd.

56&57 Hadapsar Industrial Estate
Pune,411013, India

Bhavesh Varia
Product Safety & Approvals Engineering
Issue Date: 11
September,2007



II 3 G Ex nA IIC ATEX



This certificate applies to the following equipment:

**STT 3000 –Series STT250 Smart Temperature Transmitter,
Models STT25M, STT25H,STT25S, STT25D, STT25T, (Module)**

This equipment has no arcing or sparking parts and no ignition-capable hot surfaces, and therefore conforms to Clause 6.3.1.3 of VDE 0165/2.91 and EN60079-14 for operation in Zone 2 hazardous areas, providing that the following conditions are observed. The equipment contains no intrinsically safe or energy-limiting components. The Model STT250 is a 2-wire device that receives its power and signal carrier from the same 4-20 mA signal current. Model STT250 supports thermocouple and 2-, 3-, and 4-wire RTD sensor inputs. Model STT25T supports dual thermocouple inputs. In normal operation, the maximum current is 23 mA.

Conditions for the application of the above equipment in Zone 2 hazardous areas:

1. This equipment is in compliance with the EHSR’s of the ATEX Directive 94/9/EC, EN 50021 plus a review against EN 60079-15 which showed that there were no changes which materially affected the “state of technological progress” with respect to this product.
2. Before commissioning this equipment, it must be verified that the power supply voltage cannot exceed the 30 Vdc maximum for the STT15S transmitters.
3. The temperature transmitter is a non-repairable item, and if faulty, must be replaced. The electrical power supply must be switched off before any replacement and during any time that the wiring terminations are being connected or disconnected.
4. The technical data supplied by the manufacturer must be adhered to. Install per Operator manual EN11-6190.
5. The temperature transmitter module shall be installed in enclosure IP 54 minimum.

Certificate	Protection	Description
LCIE 06 ATEX 6066X	II 1 G Ex ia IIC	Models STT25M, 4-20 mA, STT25H, 4-20 mA/HART 5, STT25S, 4-20 mA/HART6, STT25D, 4-20 mA/DE and STT25T, Dual Input and 4-20 mA/HART

Specifications for Use in Zone 2	
Supply Voltage:	9 to 30 Vdc
Supply Current:	23mA
Ambient temperature limits:	-50 to 85°C
Temperature Classification:	T6 at Ta ≤ 80°C, T5 at Ta ≤ 85°C

Manufacturer: Honeywell Automation India Ltd.
56&57 Hadapsar Industrial Estate
Pune,411013

Honeywell Automation India Ltd.
56 &57 Hadapsar Industrial Estate
Pune,411013 India

Bhavesh Varia
Product Safety & Approvals
Engineering,

Issue Date: 11
September
2007

8. CERTIFICATION

8.1 IECEx Certification

IECEx is a single global certification Framework based on the International Electrotechnical Commission's international standards. It caters to countries whose national standards are either identical to those of the IEC or else very close to IEC standards. The IECEx is truly global in concept and practice, reduces trade barriers caused by different conformity assessment criteria in various countries, and helps industry to open up new markets. The goal is to help manufacturers reduce costs and time while developing and maintaining uniform product evaluation to protect users against products that are not in line with the required level of safety.

The aim of the IECEx Scheme and its Programs is to ease international trade of Explosion Protected Equipment (termed Ex equipment) by eliminating the need for duplication of testing and certification, while preserving safety. IECEx operates as an International Certification System covering products and services associated with the Ex industries.

STT250 EQUIPMENT: IECEx LCI 08.0033X

Equipment and systems covered by this certificate are as follows:

Temperature is measured with an external sensor (thermocouple or resistor (RTD) sensor). The output from the transmitter is a 4-20 mA signal via the two-wire field connections. Letter designations in the model number specify the communications protocol:

STT25M	4-20 mA
STT25H (HART5)	HART-5 protocol and 4-20 mA
STT25H (HART6)	HART-6 protocol and 4-20 mA
STT25S	HART-6 protocol and 4-20 mA
STT25D	Digital DE / 4-20 mA
STT25T (HART5)	Dual input HART-5 / 4-20 mA
STT25T (HART6)	Dual input HART-6 / 4-20 mA

The process variable can be observed locally when the ME, SM or EU indicators (when compatible with the communications protocol) installed in the metal enclosure. The transmitter module may also be installed in a flameproof stainless steel or aluminum enclosure. The aluminum alloy contains < 6% magnesium.

CONDITIONS OF CERTIFICATION: YES as shown below:

Ambient operating temperature: -40°C to +85°C

For the intrinsic safety model:

- The temperature transmitter is an intrinsically safe apparatus; it can be placed in potentially explosive atmosphere.
- Connection of equipment:
 - the power terminal blocks (+ and –) shall only be connected to a certified associated intrinsically safe equipment
 - the sensor entry terminal blocks (1,2 , 3 and 4) shall only be connected to a certified intrinsically safe equipment or according to paragraph 5.7 of IEC 60079-1 (Ed.5) standard
- These combinations shall be compatible regarding the intrinsic safety rules
- The electrical parameters of the apparatus connected to the power terminal blocks (+ and –) shall not exceed the following values:

$$U_i \leq 30 \text{ V}; I_i \leq 100 \text{ mA}; P_i \leq 1.2 \text{ W}$$

Indicator	Li	Ci
Without indicator	0 μH	17 nF
With indicator ME	150 μH	17 nF
With indicator SM or EU	0 μH	17 nF

- The electrical parameters of the apparatus connected to the sensor entry terminal blocks (1, 2, 3 and 4) shall not exceed the following values:
 $U_o \leq 10.5 \text{ V}; I_o \leq 40 \text{ mA}; P_o \leq 0.2 \text{ W}; C_o \leq 2.08 \mu\text{F}; L_o \leq 20 \text{ mH}$
- The aluminum enclosure shall be protected against any impact or friction to be used in zone 0 (according to IEC 60079-0 requirements)#

8.2 SAEx Certified Equipment (South Africa)

This Honeywell equipment is certified as Explosion Protected Apparatus (EPA) to be installed in South Africa and must be certified by a South African ATL (Approved Test Laboratory). In South Africa, all EPA used in Group II shall be covered by an IA certificate (certificate issued by an ATL).

STT250 EQUIPMENT: SAEx S/08-371X (R1) (LCIE 06 ATEX 6066 X)

Equipment and systems covered by this certificate are as follows:

Temperature is measured with an external sensor (thermocouple or resistor (RTD) sensor). The output from the transmitter is a 4-20 mA signal via the two-wire field connections. Letter designations in the model number specify the communications protocol:

STT25M	4-20 mA
STT25H (HART5)	HART-5 protocol and 4-20 mA
STT25H (HART6)	HART-6 protocol and 4-20 mA
STT25S	HART-6 protocol and 4-20 mA
STT25D	Digital DE / 4-20 mA
STT25T (HART5)	Dual input HART-5 / 4-20 mA
STT25T (HART6)	Dual input HART-6 / 4-20 mA

The process variable can be observed locally when the ME, SM or EU indicators (when compatible with the communications protocol) installed in the metal enclosure. The transmitter module may also be installed in a flameproof stainless steel or aluminum enclosure. The aluminum alloy contains < 6% magnesium.

CONDITIONS OF CERTIFICATION:

- This certificate (which requires annual renewal) covers all units sold / used / purchased from the date of this certificate to its expiration date.
- The apparatus must be additionally marked in a clear, legible, visible and indelible manner with the SAEx marking details above.
- This certificate of approval only covers the equipment as certified above and does not include any scheduled additions or variations / amendments / new issues to the certificate(s), made after the above date.
- The equipment does not need to be retested when used on the conditions and with such restrictions as prescribed by ITACS and in this approval.
- The ITACS certification must remain valid.
- The bearing of the requirements in the ARP 0108 (or regulations) and SANS 10108 on the certification of the equipment must remain unchanged.
- The quality assurance notification must remain valid.

Sales and Service

For application assistance, current specifications, pricing, or name of the nearest Authorized Distributor, contact one of the offices below.

ASIA PACIFIC

(TAC)

hfs-tac-support@honeywell.com

Australia

Honeywell Limited
Phone: +(61) 7-3846 1255
FAX: +(61) 7-3840 6481
Toll Free 1300-36-39-36
Toll Free Fax:
1300-36-04-70

China – PRC - Shanghai

Honeywell China Inc.
Phone: (86-21) 5257-4568
Fax: (86-21) 6237-2826

Singapore

Honeywell Pte Ltd.
Phone: +(65) 6580 3278
Fax: +(65) 6445-3033

South Korea

Honeywell Korea Co Ltd
Phone: +(822) 799 6114
Fax: +(822) 792 9015

EMEA

Honeywell Process Solutions,
Phone: + 80012026455 or +44
(0)1202645583

FAX: +44 (0) 1344 655554

Email: (Sales)

sc-cp-apps-salespa62@honeywell.com

or

(TAC)

hfs-tac-support@honeywell.com

NORTH AMERICA

Honeywell Process
Solutions,
Phone: 1-800-423-9883
Or 1-800-343-0228

Email: (Sales)

ask-ssc@honeywell.com

or

(TAC)

hfs-tac-support@honeywell.com

SOUTH AMERICA

Honeywell do Brasil & Cia
Phone: +(55-11) 7266-
1900

FAX: +(55-11) 7266-1905

Email: (Sales)

ask-ssc@honeywell.com

or

(TAC)

hfs-tac-support@honeywell.com



Honeywell

AUTHORIZED DISTRIBUTOR

De Gidts & Feldman BV
The Netherlands
www.dgfg.nl



De Gidts & Feldman

INSTRUMENTATION & FILTRATION

Honeywell

Honeywell Process Solutions

1860 West Rose Garden Lane
Phoenix, Arizona 85027

www.honeywellprocess.com

EN11-6190 Revision 15

November 2012

©2012 Honeywell International Inc.