

STT 3000 Series STT170

SMART TEMPERATURE TRANSMITTER

Models STT171, STT173, STT17H, STT17F, STT17C

34-TT-03-07 3/06

PRODUCT SPECIFICATION SHEET

OVERVIEW

The Honeywell STT170 series of programmable temperature transmitters provides cost effective solutions for temperature monitoring applications. Compared to direct-wired temperature sensor monitoring points, the STT170 series of transmitters delivers increased accuracy, safety and reliability while also reducing wiring costs. These transmitters automatically linearize the temperature output signal bounded by the upper range value and lower range value established by the user. In addition, the user can program high or low limit alarms to activate in the case of sensor failure.

STT171 FEATURES

- Analog 4-20 mA output
- RTD or Ohm input
- DIN form B headmount
- NAMUR NE43 sensor error response
- Configurable using STT17C configuration tool and PC



STT173 FEATURES

- Analog 4-20 mA output
- RTD, T/C, Ohm or mV input
- DIN form B headmount
- NAMUR NE43 sensor error response
- Configurable using STT17C configuration tool and PC
- Galvanic isolation



STT17H FEATURES

- HART™/4-20 mA output
- RTD, T/C, Ohm or mV input
- Single or dual (difference or average) sensor input
- DIN form B headmount
- HART Multidrop capable
- NAMUR NE43 sensor error response
- Configurable using STT17C configuration tool and PC or HART field communicator
- Galvanic isolation



STT17F FEATURES

- FOUNDATION™ fieldbus protocol
- RTD, T/C, Ohm or mV input
- Single or dual (difference, average or redundant) sensor input
- DIN form B headmount
- Function blocks: 2 analogue, 1 PID
- FISCO certified
- Basic or LAS capability
- Galvanic isolation



HART is a registered trademark of the HART Communication Foundation.
FOUNDATION is a registered trademark of the Fieldbus Foundation.

Dimensions (all models)

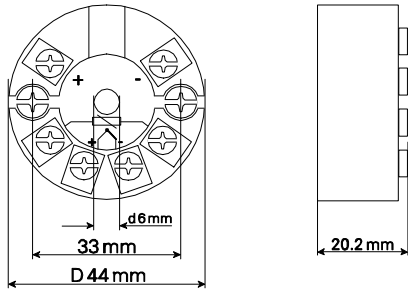

Wiring

STT171

Input:

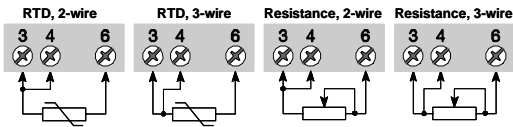

Output:

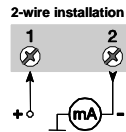

STT173

Input:

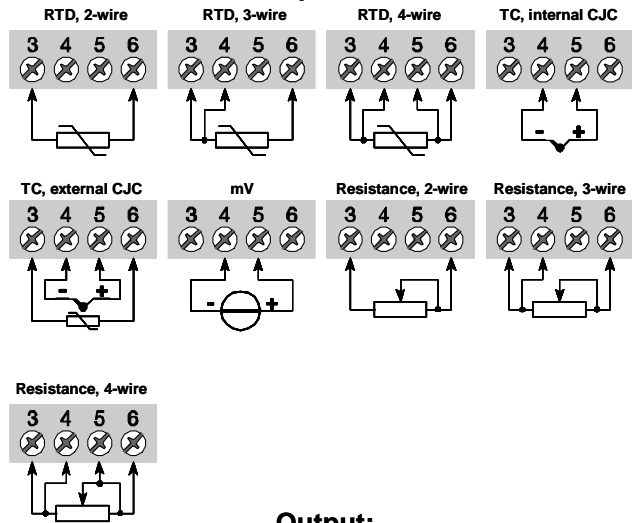

Output:

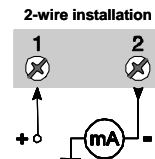

STT17H

Input:

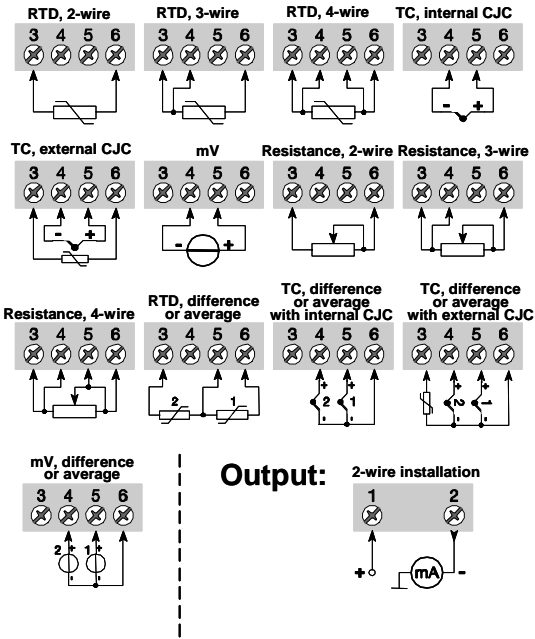

Output:

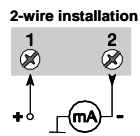

STT17F

Input:

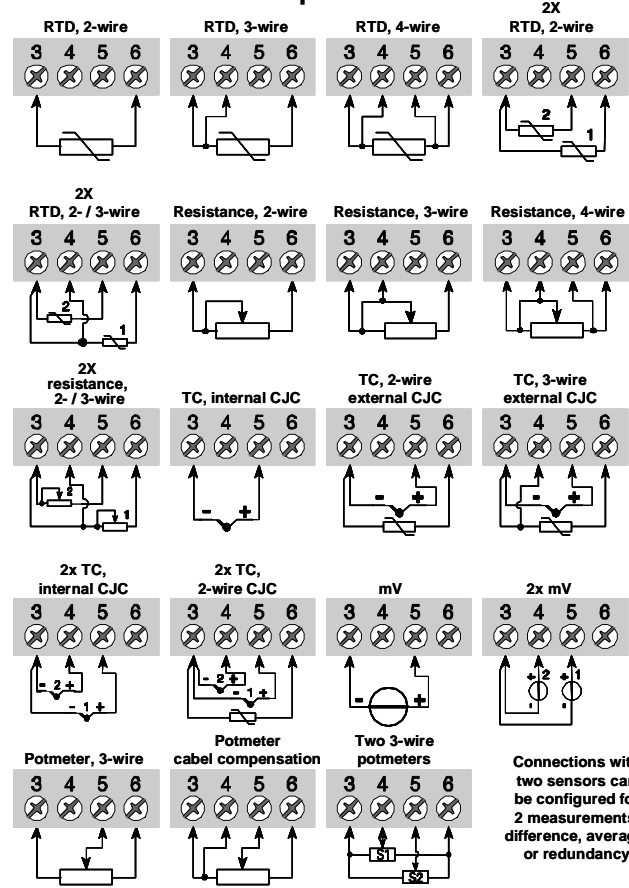

Connections with two sensors can be configured for 2 measurements, difference, average, or redundancy

Output:

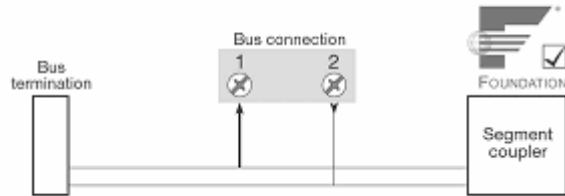

STT17C Configuration tool

The STT17C configures the STT171, STT173 and STT17H. The intuitive graphical user interface of the STT17C virtually eliminates the need for operator training after installation on a PC. The STT17C includes all software and transmitter interface hardware necessary to configure the STT171, STT173 and STT17H in non-hazardous work environments.

WARNING: The STT17C is not approved for use in Hazardous work environments.

System Requirements:

Windows® 98SE, ME, 2000 and XP with the following recommendations:

Memory:	16 MB
Display resolution:	800 x 600
Hard disk space:	12 MB

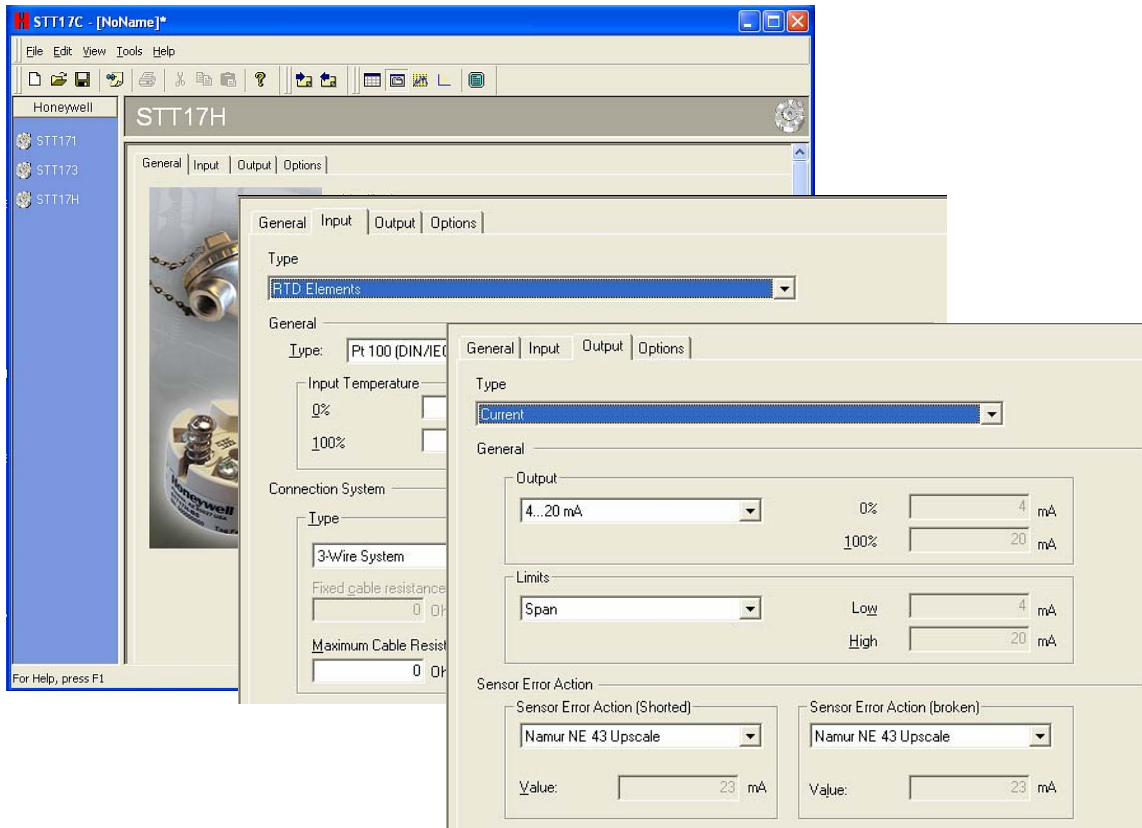
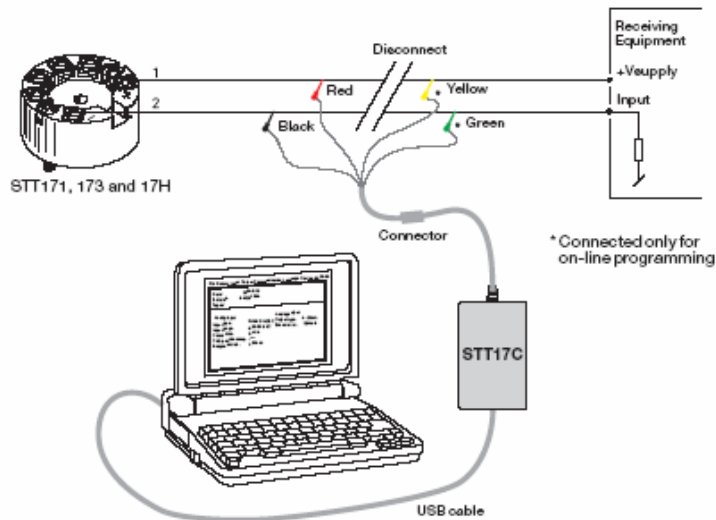

Windows is a registered trademark of Microsoft Corporation

STT171-BS Specifications

Sensor Type	Basic Accuracy*		Rated Range		Standards	Minimum Span**	Temperature Effects per 1.0°C (1.8°F) Change in Ambient Temperature***	
	Fixed	% of Span	°C	°F			Fixed	% of Span
Pt100	0.3°C (0.54°F)	± 0.1	-200 to 850	-328 to 1562	IEC60751	25°C (45°F)	0.01°C (0.018°F)	±0.01
Ni100	0.3°C (0.54°F)	± 0.1	-60 to 250	-76 to 482	DIN 43760	25°C (45°F)	0.01°C (0.018°F)	±0.01
Ω	0.2 Ω	± 0.1	0 to 10000 Ω			30 Ω	20 mΩ	±0.01

*whichever is greater; Total Reference Accuracy = Basic Accuracy

**or 50% of upper range value, whichever is greater

*** reference temperature 24°C

OPERATING CONDITIONS

Ambient temperature, rated.....-40 to 85°C (-40 to 185°F)
 Humidity..... 0 to 95% RH (non-cond.)
 Vibration..... Max 4g over 25 to 100Hz

ELECTRICAL INPUT SPECIFICATIONS

Supply voltage..... 8 to 30 VDC
 Power supply voltage effect..... ≤ 0.005% of span per VDC
 Warm-up time..... 5 min
 Response time (programmable)..... 0.33 to 60 sec

CURRENT OUTPUT SPECIFICATIONS

Signal output range..... 4 to 20 mA
 Update time..... 135 msec
 Load resistance..... ≤(V supply - 8) / 0.023 A
 0 to 870 Ω

ALARM LEVELS

Programmable..... 3.5 to 4 mA downscale
 20 to 23 mA upscale
 NAMUR NE43 Upscale..... 23 mA
 NAMUR NE43 Downscale..... 3.5 mA

APPROVALS

Observed Authority requirements:

EMC 2004/108/EC

Emmission and immunity EN 61326
 ATEX 94/9/EC..... EN 50014, EN 50020,
 EN 50281-1-1 and EN 50284
 FM, ASCN..... 3600, 3611, 3610
 CSA, CAN / CSA..... C22.2 No. 157, E60079-11,
 UL 913

Ex / I.S. approval:

KEMA 06 ATEX 0042 X.....  II 1 GD, T80°C...T105°C
 EEx ia IIC T4...T6
 Max. amb. Temperature for T4..... 85°C
 Max. amb. Temperature for T6..... 60°C
 Applicable in zone..... 0, 1, 2, 20, 21 or 22
 FM, applicable in..... IS, CL I, DIV 1, Grp. A-D, T4...T6
 AEx ia IIC
 NI, CL I, DIV 2, Grp. A-D, T4...T6
 Entity, FM Installation Drawing No..... 50016324
 CSA, applicable in..... IS, CL I, DIV 1, Grp. A-D, T4...T6
 Ex ia IIC, AEx ia IIC
 Entity, Installation Drawing No..... 50016326

Ex / I.S. data:

U_i (max)..... 30 VDC
 I_i (max)..... 120 mADC
 P_i (max)..... 0.84 W
 L_i (max)..... 10 μH
 C_i (max)..... 1.0 nF
 U_o (max)..... 27 VDC
 I_o (max)..... 7 mADC
 P_o (max)..... 45 m W
 L_o (max)..... 35 mH
 C_o (max)..... 90 nF

STT173-BS Specifications

Sensor Type	Basic Accuracy*		Rated Range		Standards	Minimum Span**	Temperature Effects per 1.0°C (1.8°F) Change in Ambient Temperature***	
	Fixed	% of Span	°C	°F			Fixed	% of Span
Pt100	0.2°C (0.36°F)	± 0.1	-200 to +850	-328 to +1562	IEC60751	25°C (45°F)	0.01°C (0.018°F)	±0.01
Ni100	0.2°C (0.36°F)	± 0.1	-60 to +250	-76 to +482	DIN 43760	25°C (45°F)	0.01°C (0.018°F)	±0.01
B	2°C (3.6°F)	± 0.1	+400 to +1820	+752 to +3308	IEC584	200°C (360°F)	0.2°C (0.36°F)	±0.01
E	1°C (1.8°F)	± 0.1	-100 to +1000	-148 to +1832	IEC584	50°C (90°F)	0.05°C (0.09°F)	±0.01
J	1°C (1.8°F)	± 0.1	-100 to +1200	-148 to +2192	IEC584	50°C (90°F)	0.05°C (0.09°F)	±0.01
K	1°C (1.8°F)	± 0.1	-180 to +1372	-192 to +2502	IEC584	50°C (90°F)	0.05°C (0.09°F)	±0.01
L	1°C (1.8°F)	± 0.1	-100 to +900	-148 to +1652	DIN 43710	50°C (90°F)	0.05°C (0.09°F)	±0.01
N	1°C (1.8°F)	± 0.1	-180 to +1300	-292 to +2372	IEC584	100°C (180°F)	0.05°C (0.09°F)	±0.01
R	2°C (3.6°F)	± 0.1	-50 to +1760	-58 to +3200	IEC584	200°C (360°F)	0.2°C (0.36°F)	±0.01
S	2°C (3.6°F)	± 0.1	-50 to +1760	-58 to +3200	IEC584	200°C (360°F)	0.2°C (0.36°F)	±0.01
T	1°C (1.8°F)	± 0.1	-200 to +400	-328 to +752	IEC584	50°C (90°F)	0.05°C (0.09°F)	±0.01
U	1°C (1.8°F)	± 0.1	-200 to +600	-328 to +1112	DIN 43710	75°C (135°F)	0.05°C (0.09°F)	±0.01
W3	2°C (3.6°F)	± 0.1	0 to +2300	+32 to +4172	ASTM E988-90	200°C (360°F)	0.2°C (0.36°F)	±0.01
W5	2°C (3.6°F)	± 0.1	0 to +2300	+32 to +4172	ASTM E988-90	200°C (360°F)	0.2°C (0.36°F)	±0.01
Ω	0.1 Ω	± 0.1	0 to 5000 Ω			30 Ω	10 mΩ	±0.01
mV	10 μV	± 0.1	-12 to 800 mV			5 mV	1 μV	±0.01

*whichever is greater; Total Reference Accuracy = Basic Accuracy + CJ Accuracy (T/C only)

**or 50% of upper range value, whichever is greater

*** reference temperature 24°C

OPERATING CONDITIONS

Ambient temperature, rated..... -40 to 85°C (-40 to 185°F)
 Humidity..... 0 to 95% RH (non-cond.)
 Vibration..... Max 4g over 25 to 100Hz
 Cold junction accuracy..... ±1.0°C

ELECTRICAL INPUT SPECIFICATIONS

Supply voltage..... 7.2 to 30 VDC
 Power supply voltage effect..... ≤ 0.005% of span per VDC
 Warm-up time..... 5 min
 Response time (programmable)..... 1 to 60 sec
 Galvanic isolation..... 1500 VAC

CURRENT OUTPUT SPECIFICATIONS

Signal output range..... 4 to 20 mA
 Update time..... 440 msec
 Load resistance (Ω)..... ≤(V supply - 7.2) / 0.023 A
 0 to 904 Ω

ALARM LEVELS

Programmable..... 3.5 to 4 mA downscale
 20 to 23 mA upscale
 NAMUR NE43 Upscale..... 23 mA
 NAMUR NE43 Downscale..... 3.5mA

APPROVALS

Observed Authority requirements:

EMC 2004/108/EC
 Emmission and immunity EN 61326
 ATEX 94/9/EC..... EN 50014, EN 50020
 FM, ASCN..... 3600, 3611, 3610
 CSA, CAN / CSA..... C22.2 No. 157, E60079-11, UL 913

Ex / I.S. approval:

KEMA 06 ATEX 0063 X.....  II 1 GD, T80°C...T105°C
 EEx ia IIC T4...T6

Max. amb. Temperature for T4..... 85°C
 Max. amb. Temperature for T6..... 60°C
 Applicable in zone..... 0, 1, 2, 20, 21 and 22
 FM, applicable in..... IS, CL I, DIV 1, Grp. A-D, T4...T6
 AEx ia IIC
 NI, CL I, DIV 2, Grp. A-D, T4...T6
 Entity, FM Installation Drawing No..... 50016324
 CSA, applicable in..... IS, CL I, DIV 1, Grp. A-D, T4...T6
 Ex ia IIC, AEx ia IIC
 Entity, Installation Drawing No..... 50016326

Ex / I.S. data:

U_i (max)..... 30 VDC
 I_i (max)..... 120 mADC
 P_i (max)..... 0.84 W
 L_i (max)..... 10 μH
 C_i (max)..... 1.0 nF
 U_o (max)..... 9.6 VDC
 I_o (max)..... 25 mADC
 P_o (max)..... 60 mW
 L_o (max)..... 33 mH
 C_o (max)..... 3.6 μF

STT17H-BS Specifications

Sensor Type	Basic Accuracy*		Rated Range		Standards	Minimum Span**	Temperature Effects per 1.0°C (1.8°F) Change in Ambient Temperature***	
	Fixed	% of Span	°C	°F			Fixed	% of Span
Pt100	0.2°C (0.36°F)	± 0.1	-200 to +850	-328 to +1562	IEC60751	10°C (18°F)	0.01°C (0.018°F)	±0.01
Pt1000	0.2°C (0.36°F)	± 0.1	-200 to +850	-328 to +1562	IEC60751	10°C (18°F)	0.01°C (0.018°F)	±0.01
Ni100	0.3°C (0.54°F)	± 0.1	-60 to +250	-76 to +482	DIN 43760	10°C (18°F)	0.01°C (0.018°F)	±0.01
B	1°C (1.8°F)	± 0.1	+400 to +1820	+752 to +3308	IEC584	100°C (180°F)	0.2°C (0.36°F)	±0.01
E	0.5°C (0.9°F)	± 0.1	-100 to +1000	-148 to +1832	IEC584	50°C (90°F)	0.05°C (0.09°F)	±0.01
J	0.5°C (0.9°F)	± 0.1	-100 to +1200	-148 to +2192	IEC584	50°C (90°F)	0.05°C (0.09°F)	±0.01
K	0.5°C (0.9°F)	± 0.1	-180 to +1372	-192 to +2502	IEC584	50°C (90°F)	0.05°C (0.09°F)	±0.01
L	0.5°C (0.9°F)	± 0.1	-100 to +900	-148 to +1652	DIN 43710	50°C (90°F)	0.05°C (0.09°F)	±0.01
N	0.5°C (0.9°F)	± 0.1	-180 to +1300	-292 to +2372	IEC584	50°C (90°F)	0.05°C (0.09°F)	±0.01
R	1°C (1.8°F)	± 0.1	-50 to +1760	-58 to +3200	IEC584	100°C (180°F)	0.2°C (0.36°F)	±0.01
S	1°C (1.8°F)	± 0.1	-50 to +1760	-58 to +3200	IEC584	100°C (180°F)	0.2°C (0.36°F)	±0.01
T	0.5°C (0.9°F)	± 0.1	-200 to +400	-328 to +752	IEC584	50°C (90°F)	0.05°C (0.09°F)	±0.01
U	0.5°C (0.9°F)	± 0.1	-200 to +600	-328 to +1112	DIN 43710	50°C (90°F)	0.05°C (0.09°F)	±0.01
W3	1°C (1.8°F)	± 0.1	0 to +2300	+32 to +4172	ASTM E988-90	100°C (180°F)	0.2°C (0.36°F)	±0.01
W5	1°C (1.8°F)	± 0.1	0 to +2300	+32 to +4172	ASTM E988-90	100°C (180°F)	0.2°C (0.36°F)	±0.01
Ω	0.1 Ω	± 0.1	0 to 7000 Ω			25 Ω	5 mΩ	±0.01
mV	10 μV	± 0.1	-800 to 800 mV			5 mV	0.5 μV	±0.01

*whichever is greater; Total Reference Accuracy = Basic Accuracy + CJ Accuracy (T/C only)

**or 50% of upper range value, whichever is greater

*** reference temperature 24°C

OPERATING CONDITIONS

Ambient temperature, rated.....	-40 to 85°C (-40 to 185°F)
Humidity.....	0 to 95% RH (non-cond.)
Vibration.....	Max 4g over 25 to 100Hz
Cold junction accuracy.....	±1.0°C

ELECTRICAL INPUT SPECIFICATIONS

Supply Voltage.....	8 to 30 VDC
Power supply voltage effect.....	≤ 0.005% of span per VDC
Warm-up time.....	30 sec
Response time (programmable).....	1 to 60 sec
Galvanic isolation.....	1500 VAC

CURRENT OUTPUT SPECIFICATIONS

Signal output range.....	4 to 20 mA
Update time.....	440 msec
Load resistance (Ω).....	≤(V supply - 8) / 0.023 A 0 to 870 Ω

ALARM LEVELS

Programmable.....	3.5 to 4 mA downscale 20 to 23 mA upscale
NAMUR NE43 Upscale.....	23 mA
NAMUR NE43 Downscale.....	3.5 mA

APPROVALS

Observed Authority requirements:	Standard:
EMC 2004/108/EC	Emmission and immunity EN 61326
ATEX 94/9/EC.....	EN 50014, EN 50020, EN 50281-1-1 and EN 50284
FM, ASCN.....	3600, 3611, 3610
CSA, CAN / CSA.....	C22.2 No. 157, E60079-11, UL 913
Ex / I.S. approval:	
KEMA 06 ATEX 0044 X.....	⊕ II 1 GD, T80°C...T105°C EEx ia IIC T4...T6
Max. amb. Temperature for T4.....	85°C
Max. amb. Temperature for T6.....	60°C
Applicable in zone.....	0, 1, 2, 20, 21 or 22
FM, applicable in.....	IS, CL I, DIV 1, Grp. A-D, T4...T6 AEx ia IIC
Entity, FM Installation Drawing No.....	NI, CL I, DIV 2, Grp. A-D, T4...T6 50016324
CSA, applicable in.....	IS, CL I, DIV 1, Grp. A-D, T4...T6 Ex ia IIC, AEx ia IIC
Entity, Installation Drawing No.....	50016326

Ex / I.S. data:

U _i (max).....	30 VDC
I _i (max).....	120 mADC
P _i (max).....	0.84 W
L _i (max).....	10 μH
C _i (max).....	1.0 nF
U _o (max).....	9.6 VDC
I _o (max).....	28 mADC
P _o (max).....	67 mW
L _o (max).....	33 mH
C _o (max).....	3.5 μF

STT17H-BN Specifications

Sensor Type	Basic Accuracy*		Rated Range		Standards	Minimum Span**	Temperature Effects per 1.0°C (1.8°F) Change in Ambient Temperature***	
	Fixed	% of Span	°C	°F			Fixed	% of Span
Pt100	0.2°C (0.36°F)	± 0.1	-200 to +850	-328 to +1562	IEC60751	10°C (18°F)	0.01°C (0.018°F)	±0.01
Pt1000	0.2°C (0.36°F)	± 0.1	-200 to +850	-328 to +1562	IEC60751	10°C (18°F)	0.01°C (0.018°F)	±0.01
Ni100	0.3°C (0.54°F)	± 0.1	-60 to +250	-76 to +482	DIN 43760	10°C (18°F)	0.01°C (0.018°F)	±0.01
B	1°C (1.8°F)	± 0.1	+400 to +1820	+752 to +3308	IEC584	100°C (180°F)	0.2°C (0.36°F)	±0.01
E	0.5°C (0.9°F)	± 0.1	-100 to +1000	-148 to +1832	IEC584	50°C (90°F)	0.05°C (0.09°F)	±0.01
J	0.5°C (0.9°F)	± 0.1	-100 to +1200	-148 to +2192	IEC584	50°C (90°F)	0.05°C (0.09°F)	±0.01
K	0.5°C (0.9°F)	± 0.1	-180 to +1372	-192 to +2502	IEC584	50°C (90°F)	0.05°C (0.09°F)	±0.01
L	0.5°C (0.9°F)	± 0.1	-100 to +900	-148 to +1652	DIN 43710	50°C (90°F)	0.05°C (0.09°F)	±0.01
N	0.5°C (0.9°F)	± 0.1	-180 to +1300	-292 to +2372	IEC584	50°C (90°F)	0.05°C (0.09°F)	±0.01
R	1°C (1.8°F)	± 0.1	-50 to +1760	-58 to +3200	IEC584	100°C (180°F)	0.2°C (0.36°F)	±0.01
S	1°C (1.8°F)	± 0.1	-50 to +1760	-58 to +3200	IEC584	100°C (180°F)	0.2°C (0.36°F)	±0.01
T	0.5°C (0.9°F)	± 0.1	-200 to +400	-328 to +752	IEC584	50°C (90°F)	0.05°C (0.09°F)	±0.01
U	0.5°C (0.9°F)	± 0.1	-200 to +600	-328 to +1112	DIN 43710	50°C (90°F)	0.05°C (0.09°F)	±0.01
W3	1°C (1.8°F)	± 0.1	0 to +2300	+32 to +4172	ASTM E988-90	100°C (180°F)	0.2°C (0.36°F)	±0.01
W5	1°C (1.8°F)	± 0.1	0 to +2300	+32 to +4172	ASTM E988-90	100°C (180°F)	0.2°C (0.36°F)	±0.01
Ω	0.1 Ω	± 0.1	0 to 7000 Ω			25 Ω	5 mΩ	±0.01
mV	10 μV	± 0.1	-800 to 800 mV			5 mV	0.5 μV	±0.01

*whichever is greater; Total Reference Accuracy = Basic Accuracy + CJ Accuracy (T/C only)

**or 50% of upper range value, whichever is greater

*** reference temperature 24°C

OPERATING CONDITIONS

Ambient temperature, rated..... -40 to 85°C (-40 to 185°F)
 Humidity..... 0 to 95% RH (non-cond.)
 Vibration..... Max 4g over 25 to 100Hz
 Cold junction accuracy..... ±1.0°C

ELECTRICAL INPUT SPECIFICATIONS

Supply Voltage..... 8 to 35 VDC
 Power supply voltage effect..... ≤ 0.005% of span per VDC
 Warm-up time..... 30 sec
 Response time (programmable)..... 1 to 60 sec
 Galvanic isolation..... 1500 VAC

CURRENT OUTPUT SPECIFICATIONS

Signal output range..... 4 to 20 mA
 Update time..... 440 msec
 Load resistance (Ω)..... ≤(V supply - 8) / 0.023 A
 0 to 1174 Ω

ALARM LEVELS

Programmable..... 3.5 to 4 mA downscale
 20 to 23 mA upscale
 NAMUR NE43 Upscale..... 23 mA
 NAMUR NE43 Downscale..... 3.5 mA

APPROVALS

Observed Authority requirements: **Standard:**
 EMC 2004/108/EC
 Emmission and immunity EN 61326
 ATEX 94/9/EC..... EN 60079-0, EN 60079-15

Ex / I.S. approval:

KEMA 06 ATEX 0043 X.....  II 3 GD, T80°C...T105°C
 EEx nA [L] IIC T4...T6
 Applicable in zone..... 2
 Max. amb. Temperature for T4..... 85°C
 Max. amb. Temperature for T6..... 60°C
 Vmax..... 35V

STT17F-BS Specifications

Sensor Type	Basic Accuracy*		Rated Range		Standards	Temperature Effects per 1.0°C (1.8°F) Change in Ambient Temperature**	
	Fixed	% of reading	°C	°F		Fixed	% of reading
Pt100	0.2°C (0.36°F)	± 0.1	-200 to +850	-328 to +1562	IEC60751	0.01°C (0.018°F)	±0.01
Pt1000	0.2°C (0.36°F)	± 0.1	-200 to +850	-328 to +1562	IEC60751	0.01°C (0.018°F)	±0.01
Ni100	0.3°C (0.54°F)	± 0.1	-60 to +250	-76 to +482	DIN 43760	0.01°C (0.018°F)	±0.01
Cu10	1.3°C (2.3°F)	± 0.1	-50 to +200	-58 to +392	α = 0.00427	0.02°C (0.036°F)	±0.01
B	1°C (1.8°F)	± 0.1	+400 to +1820	+752 to +3308	IEC584	0.2°C (0.36°F)	±0.01
E	0.5°C (0.9°F)	± 0.1	-100 to +1000	-148 to +1832	IEC584	0.05°C (0.09°F)	±0.01
J	0.5°C (0.9°F)	± 0.1	-100 to +1200	-148 to +2192	IEC584	0.05°C (0.09°F)	±0.01
K	0.5°C (0.9°F)	± 0.1	-180 to +1372	-192 to +2502	IEC584	0.05°C (0.09°F)	±0.01
L	0.5°C (0.9°F)	± 0.1	-200 to +900	-328 to +1652	DIN 43710	0.05°C (0.09°F)	±0.01
N	0.5°C (0.9°F)	± 0.1	-180 to +1300	-292 to +2372	IEC584	0.05°C (0.09°F)	±0.01
R	1°C (1.8°F)	± 0.1	-50 to +1760	-58 to +3200	IEC584	0.2°C (0.36°F)	±0.01
S	1°C (1.8°F)	± 0.1	-50 to +1760	-58 to +3200	IEC584	0.2°C (0.36°F)	±0.01
T	0.5°C (0.9°F)	± 0.1	-200 to +400	-328 to +752	IEC584	0.05°C (0.09°F)	±0.01
U	0.5°C (0.9°F)	± 0.1	-200 to +600	-328 to +1112	DIN 43710	0.05°C (0.09°F)	±0.01
W3	1°C (1.8°F)	± 0.1	0 to +2300	+32 to +4172	ASTM E988-90	0.2°C (0.36°F)	±0.01
W5	1°C (1.8°F)	± 0.1	0 to +2300	+32 to +4172	ASTM E988-90	0.2°C (0.36°F)	±0.01
Ω	0.05 Ω	± 0.1	0 to 10000 Ω			2 mΩ	±0.01
mV	10 μV	± 0.1	-800 to 800 mV			0.2 μV	±0.01

*whichever is greater; Total Reference Accuracy = Basic Accuracy + CJ Accuracy (T/C only)
 ** reference temperature 24°C

OPERATING CONDITIONS

Ambient temperature, rated..... -40 to 85°C (-40 to 185°F)
 Humidity..... 0 to 95% RH (non-cond.)
 Vibration..... Max 4g over 25 to 100Hz
 Cold junction accuracy..... ±0.5°C

ELECTRICAL INPUT SPECIFICATIONS

Supply Voltage..... 9 to 30 VDC
 In FISCO installations..... 9 to 17.5 VDC
 Consumption..... < 11 mA
 Warm-up time..... 30 sec
 Response time (programmable)..... 1 to 60 sec
 Galvanic isolation..... 1500 VAC
 Update time..... < 400 msec
 Execution time, PID controller..... < 200 msec
 Execution time, analogue input..... < 50 msec

OUTPUT SPECIFICATIONS

Foundation™ Fieldbus connection:

Foundation™ Fieldbus version..... ITK 4.6
 Foundation™ F. capability..... Basic or LAS
 Foundation™ F. function blocks..... 2 analogue and 1 PID

Ex / I.S. data:

Unit	Class I, Zone 0, EEx ia IIC, Entity/FISCO			
	IS, Class I, Division 1, Group A, B, C, D, Entity/FISCO			
	Barrier where Po < 0.84 W	Barrier where Po < 1.3 W	Suitable for FISCO systems	Suitable for FISCO systems
Ui	30 VDC	30 VDC	17.5 VDC	15 VDC
Ii	120 mADC	300 mADC	250 mADC	900 mADC
Pi	0.84 W	1.3 W	2.0 W	5.32 W
Li	1 μH	1 μH	1 μH	1 μH
Ci	2.0 nF	2.0 nF	2.0 nF	2.0 nF
T1...T4	Tamb. < 85°C	Tamb. < 75°C	Tamb. < 85°C	Tamb. < 85°C
T5	Tamb. < 70°C	Tamb. < 65°C	Tamb. < 60°C	Tamb. < 60°C
T6	Tamb. < 60°C	Tamb. < 45°C	Tamb. < 45°C	Tamb. < 45°C

APPROVALS

Observed Authority requirements: Standard:

EMC 2004/108/EC
 Emmission and immunity EN 61326
 ATEX 94/9/EC..... EN 50014, EN 50020, EN 50281-1-1, EN 50284, and IEC 60079-27 (FISCO)
 FM, ASCN..... 3600, 3611, 3610
 CSA, CAN / CSA..... C22.2 No. 142, No. 157
 CAN / CSA..... E60079-0, E60079-11, E60079-15, UL913, UL1604

Ex / I.S. approval:

KEMA 06 ATEX 0046.....  II 1 GD, T65°C...T105°C
 EEx ia IIC T4...T6
 Ex II 2(1) GD, T65oC...T105oC
 EEx ib [ia] IIC T4...T6

Applicable in zone..... 0, 1, 2, 20, 21 or 22
 FM, applicable in..... IS, CL I, DIV 1, Grp. A-D, T4...T6
 AEx ia IIC
 NI, CL I, DIV 2, Grp. A-D, T4...T6
 Entity, FM Installation Drawing No..... 50016325
 CSA, applicable in..... IS, CL I, DIV 1, Grp. A-D, T4...T6
 Ex ia IIC, AEx ia IIC
 CL I, DIV 2, Grp. A-D, T4...T6
 Entity, CSA Installation Drawing No..... 50016325

Ex / I.S. data:

Unit	Class I, Zone 1, EEx ib IIC, Entity/FISCO	
	IS, Class I, Division 2, Group A, B, C, D, Entity/FISCO	
	Barrier where Po < 5.32 W	FISCO segment coupler
Ui	30 VDC	17.5 VDC
Ii	250 mADC	All
Pi	5.32 W	All
Li	1 μH	1 μH
Ci	2.0 nF	2.0 nF
T1...T4	Tamb. < 85°C	Tamb. < 85°C
T5	Tamb. < 75°C	Tamb. < 75°C
T6	Tamb. < 60°C	Tamb. < 60°C

STT17F-BN Specifications

Sensor Type	Basic Accuracy*		Rated Range		Standards	Temperature Effects per 1.0°C (1.8°F) Change in Ambient Temperature**	
	Fixed	% of reading	°C	°F		Fixed	% of reading
Pt100	0.2°C (0.36°F)	± 0.1	-200 to +850	-328 to +1562	IEC60751	0.01°C (0.018°F)	±0.01
Pt1000	0.2°C (0.36°F)	± 0.1	-200 to +850	-328 to +1562	IEC60751	0.01°C (0.018°F)	±0.01
Ni100	0.3°C (0.54°F)	± 0.1	-60 to +250	-76 to +482	DIN 43760	0.01°C (0.018°F)	±0.01
Cu10	1.3°C (2.3°F)	± 0.1	-50 to +200	-58 to +392	$\alpha = 0.00427$	0.02°C (0.036°F)	±0.01
B	1°C (1.8°F)	± 0.1	+400 to +1820	+752 to +3308	IEC584	0.2°C (0.36°F)	±0.01
E	0.5°C (0.9°F)	± 0.1	-100 to +1000	-148 to +1832	IEC584	0.05°C (0.09°F)	±0.01
J	0.5°C (0.9°F)	± 0.1	-100 to +1200	-148 to +2192	IEC584	0.05°C (0.09°F)	±0.01
K	0.5°C (0.9°F)	± 0.1	-180 to +1372	-192 to +2502	IEC584	0.05°C (0.09°F)	±0.01
L	0.5°C (0.9°F)	± 0.1	-200 to +900	-328 to +1652	DIN 43710	0.05°C (0.09°F)	±0.01
N	0.5°C (0.9°F)	± 0.1	-180 to +1300	-292 to +2372	IEC584	0.05°C (0.09°F)	±0.01
R	1°C (1.8°F)	± 0.1	-50 to +1760	-58 to +3200	IEC584	0.2°C (0.36°F)	±0.01
S	1°C (1.8°F)	± 0.1	-50 to +1760	-58 to +3200	IEC584	0.2°C (0.36°F)	±0.01
T	0.5°C (0.9°F)	± 0.1	-200 to +400	-328 to +752	IEC584	0.05°C (0.09°F)	±0.01
U	0.5°C (0.9°F)	± 0.1	-200 to +600	-328 to +1112	DIN 43710	0.05°C (0.09°F)	±0.01
W3	1°C (1.8°F)	± 0.1	0 to +2300	+32 to +4172	ASTM E988-90	0.2°C (0.36°F)	±0.01
W5	1°C (1.8°F)	± 0.1	0 to +2300	+32 to +4172	ASTM E988-90	0.2°C (0.36°F)	±0.01
Ω	0.05 Ω	± 0.1	0 to 10000 Ω			2 m Ω	±0.01
mV	10 μ V	± 0.1	-800 to 800 mV			0.2 μ V	±0.01

*whichever is greater; Total Reference Accuracy = Basic Accuracy + CJ Accuracy (T/C only)

** reference temperature 24°C

OPERATING CONDITIONS

Ambient temperature, rated.....	-40 to 85°C (-40 to 185°F)
Humidity.....	0 to 95% RH (non-cond.)
Vibration.....	Max 4g over 25 to 100Hz
Cold junction accuracy.....	±0.5°C
Reference temperature.....	20 to 28°C

ELECTRICAL INPUT SPECIFICATIONS

Supply Voltage.....	9 to 32 VDC
Consumption.....	< 11 mA
Warm-up time.....	30 sec
Response time (programmable).....	1 to 60 sec
Galvanic isolation.....	1500 VAC
Update time.....	< 400 msec
Execution time, PID controller.....	< 200 msec
Execution time, analogue input.....	< 50 msec

OUTPUT SPECIFICATIONS

Foundation™ Fieldbus connection:

Foundation™ Fieldbus version.....	ITK 4.6
Foundation™ F. capability.....	Basic or LAS
Foundation™ F. function blocks.....	2 analogue and 1 PID

APPROVALS

Observed Authority requirements: Standard:
EMC 2004/108/EC

Emmission and immunity EN 61326

ATEX 94/9/EC.....	EN 60079-0, EN 60079-15
FM, ASCN.....	3600, 3611
CSA, CAN / CSA.....	C22.2 No. 142, No. 213
CAN / CSA.....	E60079-0, E60079-15, UL1604

Ex / I.S. approval:

KEMA 06 ATEX 0045 X.....	 II 3 G
	EEx nA [L] IIC T4...T6
Applicable in zone.....	2
FM, applicable in.....	NI, CL I, DIV 2, Grp. A-D, T4...T6
	FNICO
Entity, FM Installation Drawing No.....	50016325
CSA, applicable in.....	CL I, DIV 2, Grp. A-D, T4...T6
	CL I, Zone 2,
	Ex nA IIC, AEx nA IIC
Entity, CSA, Installation Drawing No....	50016325
Max. amb. Temperature for T4.....	85°C
Max. amb. Temperature for T6.....	60°C

Vmax.....	32V
Li.....	1 μ H
Ci.....	2.0 nF

STT171 Custom Configuration Data Sheet

Customer P.O. Number _____

Line Item _____

Model Number _____

Tag Number (max 15 char) _____

Honeywell Sales Order Number _____

Sensor Type:

- Pt100
- Ni100
- Ohms

Output Values:

4 mA Value:

- _____ °C
- _____ °F
- _____ Ohms

20 mA Value:

- _____ °C
- _____ °F
- _____ Ohms

Response time:

_____ (0.33 – 60 sec)

Output Limits:

- Span (4 to 20 mA)
- Max (3.5 to 23 mA)
- Specify Low _____ mA, High _____ mA
- NAMUR NE 43 (3.8 to 20.5 mA)

Sensor Error Action:

- Off
- Specify _____ mA
- NAMUR NE 43 upscale (23 mA)
- NAMUR NE 43 downscale (3.5 mA)

STT173 Custom Configuration Data Sheet

Customer P.O. Number _____

Line Item _____

Model Number _____

Tag Number (max 15 char) _____

Honeywell Sales Order Number _____

Sensor Type:

Pt100

Ni100

Wiring:

2-wire

3-wire

4-wire

Ohms

mV

Type B T/C

Type E T/C

Type J T/C

Type K T/C

Type L T/C

Type N T/C

Type R T/C

Type S T/C

Type T T/C

Type U T/C

Type W3 T/C

Type W5 T/C

Cold Junction Compensation:

Internal

External / Pt100

External / Ni100

Output Values:

4 mA Value:

_____ °C

_____ °F

_____ mV

_____ Ohms

20 mA Value:

_____ °C

_____ °F

_____ mV

_____ Ohms

Response time:

_____ (1 – 60 sec)

Output Limits:

Span (4 to 20 mA)

Max (3.5 to 23 mA)

Specify Low _____ mA, High _____ mA

NAMUR NE 43 (3.8 to 20.5 mA)

Sensor Error Action:

Off

Specify _____ mA

NAMUR NE 43 upscale (23 mA)

NAMUR NE 43 downscale (3.5 mA)

STT17H Custom Configuration Data Sheet

Customer P.O. Number _____

Line Item _____

Model Number _____

Tag Number (max 15 char) _____

Honeywell Sales Order Number _____

Sensor Type:

- Pt100
- Ni100

Wiring:

- 2-wire
- 3-wire
- 4-wire
- Average
- Differential

- Ohms
- mV

- Type B T/C
- Type E T/C
- Type J T/C
- Type K T/C
- Type L T/C
- Type N T/C
- Type R T/C
- Type S T/C
- Type T T/C
- Type U T/C
- Type W3 T/C
- Type W5 T/C

Cold Junction Compensation:

- Internal
- External / Pt100
- External / Ni100

Output Values:

4 mA Value:

- _____ °C
- _____ °F
- _____ mV
- _____ Ohms

20 mA Value:

- _____ °C
- _____ °F
- _____ mV
- _____ Ohms

Response time:

_____ (1 – 60 sec)

Output Limits:

- Span (4 to 20 mA)
- Max (3.5 to 23 mA)
- Specify Low _____ mA, High _____ mA
- NAMUR NE 43 (3.8 to 20.5 mA)

Sensor Error Action:

- Off
- Specify _____ mA
- NAMUR NE 43 upscale (23 mA)
- NAMUR NE 43 downscale (3.5 mA)

Instructions

- Choose Availability column based on Key Number.
A dot (♦) denotes unrestricted availability.
- Select the desired Key Number based on the desired communications protocol.
- Select options and approvals from Tables.

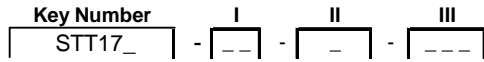

Key Number	Description	Selection	Availability				
	4-20mA Output, RTD input	STT171	↓				
	4-20mA Output, universal input	STT173		↓			
	HART Protocol, 4-20mA output	STT17H			↓		
	Digital output, Foundation Fieldbus protocol	STT17F				↓	
	Configuration tool for STT171, 173 and 17H	STT17C					↓

TABLE I - Safety Approvals

Approval Body	Approval Type	Location or Classification					
None	No approval body certifications included		00				♦
FM, CSA, ATEX	Intrinsically Safe ENTITY	Class I, Div. 1, Groups A,B,C,D, T4 Class I, Zone 0/1; AEx ia IIC, T4	BS				
	Non-Incendive	Class I, Div. 2, Groups A,B,C,D, T4					
	Intrinsically Safe ENTITY	Class I, Div. 2, Groups A,B,C,D, T4 Class I, Zone 0/1; Ex ia IIC, T4		♦	♦	♦	♦
	Non-Incendive	Class I, Div. 2, Groups A,B,C,D, T4					
	* Intrinsically Safe Zone 0/1	Ex II 1 GD, EEx ia IIC, T4..T6 Ex II 2 (1) GD, T4..T6					
	Non-Incendive Zone 2	Class I, Div. 2, Groups A,B,C,D, T4 Ex II 3 G, EEx nA [L] T4..T6	BN			♦	♦

* Ex II 1 GD or II 2 (1) GD allows for installation in potentially explosive atmospheres caused by the presence of combustible dusts only when mounted in a metal enclosure of form B according to DIN 43729 (Head-Mount enclosure) that provides a degree of protection of at least IP 6X in accordance with EN 60529, that is suitable for the application and correctly installed.

TABLE II - Sensor, Probe and Thermowell

No Integral Sensor Probe Available	0	♦	♦	♦	♦	♦
------------------------------------	---	---	---	---	---	---

TABLE III - Configuration & Certificates

Configuration	None - Factory Default Configuration Supplied	0 __	♦	♦	♦	♦	♦
	Custom Transmitter Configuration with Printed Report	T __	♦	♦	♦		
Optional Certificates	No Certificate of Calibration	_ 0 _	♦	♦	♦	♦	♦
	Certificate of Calibration	_ C _	♦	♦	♦		
	No Certificate of Conformance/Origin	_ _ 0	♦	♦	♦	♦	♦
	Certificate of Conformance/Origin	_ _ R	♦	♦	♦	♦	

Accessories

	Part Number
DIN rail clip	50017850-001



Honeywell

AUTHORIZED DISTRIBUTOR

De Gidts & Feldman BV
The Netherlands
w w w . d g f g . n l



De Gidts & Feldman

INSTRUMENTATION & FILTRATION

This page intentionally blank

Honeywell

Honeywell Process Solutions

2500 W. Union Hills Drive, Phoenix, AZ 85027, (602) 313-5000

© 2006Honeywell International Inc.